



# AHNB

**TOOLING & MACHINERY, INC.**

**COMPLETE METALWORKING SOLUTIONS**

(800) 991-4225  
ISO Certified

www.ahbinc.com  
customerservice@ahbinc.com



**POWER CHUCKS  
ROTARY CYLINDERS**

**2017**



Distributed by  
**Global Tooling Solutions, LLC**

Po Box 701  
Walpole, MA 02081  
800-985-5390  
sales@gts-tools.com  
www.gts-tools.com

<http://www.gts-tools.com/autogrip-power-chucks.html>





# The Autogrip Company



## The Autogrip Company

Autogrip machinery was established in 1989 in Taiwan. Our product lines focus on power chucks, rotary cylinders and other automatic clamping products. Autogrip provides workholding solutions for our customers worldwide.

Integrity and professionalism, we provide high quality engineered products and exceptional service for our customers.

Our factory is located in central Taiwan and occupies over 10,000 square meters of office, manufacturing and warehouse space.

## Why Autogrip?

**Product Quality** – High accuracy, rigidity and durability are all characteristics of the Autogrip line.

**Product Offering** – Wedge, lever and pull back styles. Standard and long jaw stroke options. Standard thru-hole, large thru-hole and closed centers. One, two, three and six jaw configurations. Hydraulic, pneumatic and stationary chucks. 3" – 79" sizes. Collet chucks and a wide variety of cylinders. Autogrip has the product to support all of your power chuck requirements.

**Custom Design Services** – Got a special workholding challenge? Autogrip can help. It starts with our engineering excellence and extensive manufacturing capabilities. Special top tooling configurations, closed or open thru-holes, workplace seating options, cylinder modifications and a variety of other options to support all of your workholding challenges.

**Value** – Autogrip provides the best combination of quality, service and pricing and is the best value for power workholding solutions on the US and global markets.



# Quality Testing Lab

Autogrip is focused on quality and has developed a state of the art mechanical testing lab to ensure product quality is controlled and product quality is consistently delivered to the customer.

All new product developed by Autogrip goes through a rigorous series of tests to ensure that performance and accuracy meet all of the design specifications.

Autogrip performs routine testing on existing product groups to ensure that products are continually manufactured to the highest quality standards.

## Dynamic Gripping Force Test

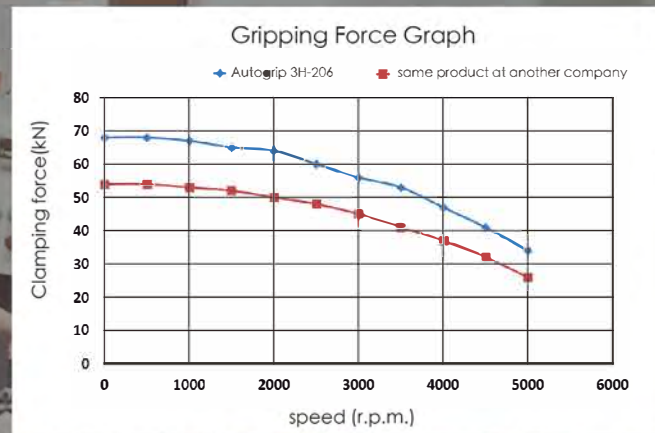

## Dynamic Oil Leaking Test

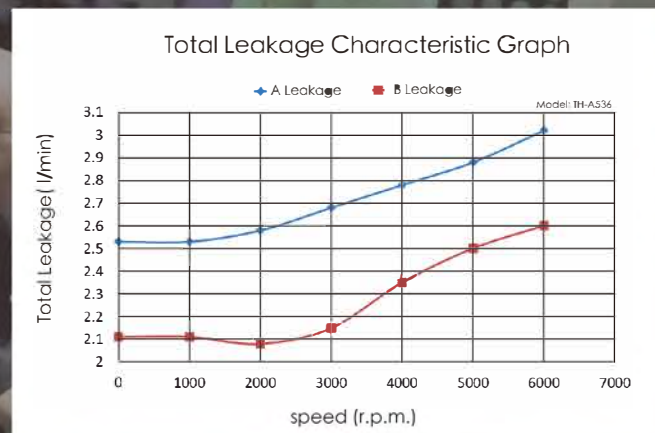



AUTOGRIP

# Quick Jaw Change Chuck



# 3Q

## QUICK JAW CHANGE SERIES

### QUICK CHANGE JAWS SAVE YOU TIME IMPROVING WORKFLOW AND EFFICIENCIES

#### FEATURES

- Quick change top jaws with high precision and repeatability.
- All chuck parts are hardened and precision ground.
- High rigidity and clamping accuracy.



#### EASY TO CHANGE JAW IN 2 STEPS



1. Turn T-handle counter clockwise to release and move jaw forward to its position.



2. Turn T-handle clockwise to tighten and the jaw is locked.





## 3V series

The maximum diameter is  
**2000mm (79")**

- It's a WEDGE-STYLE type 3-jaw high speed power chuck.
- With manual radial setting of master jaws for the workpieces centering
- Sealed against swarf, chips and coolant, suitable for vertical lathe.

Various Models / Sizes:  
Available in 3, 4 and 6-jaw versions  
with sizes 12 to 79 inch diameter.



Rotary cylinder: RE series



# Pneumatic Power Chuck



## Product Patented

US	US8770222 B2
Germany	20.2011.101.818.4 20.2012.102.498.5
Japan	3169457 / 3178706
EU	EP 2517822 B1
China	ZL 2011 2 0141324.9 ZL 2012 2 0274549.6
Taiwan	M440159 / M415011

## PATENTED AIR FEED SYSTEM

- Built-in cylinder
- Check valve
- Pressure detection
- Unique design

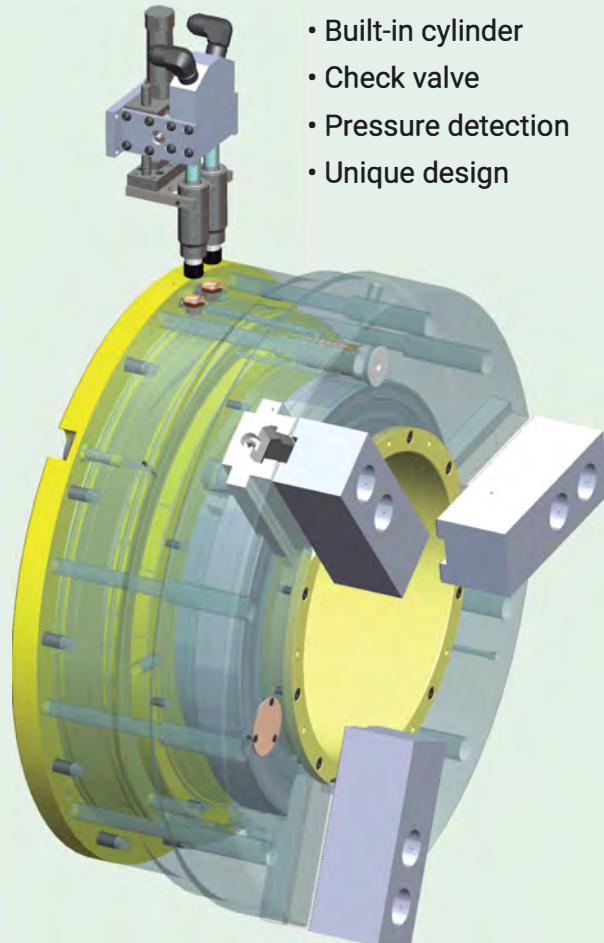

# AP series

### Advantages:

- Large thru-hole:  $\text{Ø}52\text{mm} \sim \text{Ø}375\text{mm}$
- No distributor ring needed
- Easy to install
- Less maintenance



# Stationary Chuck Base Plate



## 4-plate

### FEATURES:

- For milling machine / machining center
- Allow simultaneous machining with up to 4 chucks (Order can be customized for 2,3,6 grippers)
- Work with SP/SD/SU/SE vertical chuck
- Driven by Hydraulic or Pneumatic
- Individual circuit for each chuck
- Special design and reduce the height of working surface.
- Lock valve unit (option)
- Air tight detection function (optional)



**SU**  
**STATIONARY PULL LOCK CHUCK**

- Pull lock
- Heavy duty machining
- Air tight detection



**SD**  
**STATIONARY PULL BACK CHUCK**

- Pull back
- Heavy duty machining
- Air tight detection



**SE**  
**STATIONARY PULL BACK CHUCK FOR INTERNAL GRIPPING**

- Pull back
- Air tight detection











**SP**  
**3-JAW NON-THRU-HOLE VERTICAL CHUCK**

- Wedge-hook type 3-jaw vertical chuck

















# INDEX [ Product Description ]

## Power Chucks

 <p>High Speed Thru-Hole Power Chuck <b>3H/3H-A</b> WEDGE-HOOK TYPE 3-JAW THRU-HOLE POWER CHUCK Thru-Hole 3-Jaw 17</p>	 <p>Large Thru-Hole <b>3H-B/3H-BA</b> WEDGE-HOOK TYPE 3-JAW EXTRA THRU-HOLE POWER CHUCK Thru-Hole 3-Jaw 18</p>	 <p>High Speed Thru-Hole Power Chuck <b>2H/2H-A</b> WEDGE-HOOK TYPE 2-JAW THRU-HOLE POWER CHUCK Thru-Hole 2-Jaw 19</p>
 <p>High Speed Thru-Hole Power Chuck <b>4H/4H-A</b> WEDGE-HOOK TYPE 4-JAW THRU-HOLE POWER CHUCK Thru-Hole 4-Jaw 20</p>	 <p>High Speed Thru-Hole Power Chuck <b>3P/3P-A</b> WEDGE-HOOK TYPE 3-JAW POWER CHUCK Non-Thru-Hole 3-Jaw 21</p>	 <p>High Speed Thru-Hole Power Chuck <b>2P/2P-A</b> WEDGE-HOOK TYPE 2-JAW POWER CHUCK Non-Thru-Hole 2-Jaw 24</p>
 <p>Large Thru-Hole <b>3L/3L-A</b> CRANK TYPE 3-JAW EXTRA LONG JAW STROKE THRU-HOLE POWER CHUCK Thru-Hole 3-Jaw 25</p>	 <p>Large Thru-Hole <b>2L/2L-A</b> CRANK TYPE 2-JAW EXTRA LONG JAW STROKE THRU-HOLE POWER CHUCK Thru-Hole 2-Jaw 26</p>	 <p>Long Stroke <b>1L</b> EXTRA LONG JAW STROKE POWER CHUCK Non-Thru-Hole 1-Jaw 27</p>
 <p>Long Jaw Stroke <b>3M</b> WEDGE-HOOK TYPE 3-JAW LONG JAW STROKE POWER CHUCK Non-Thru-Hole 3-Jaw 28</p>	 <p>Long Jaw Stroke <b>2M</b> WEDGE-HOOK TYPE 2-JAW LONG JAW STROKE POWER CHUCK Non-Thru-Hole 2-Jaw 30</p>	 <p>For Vertical Lathe <b>3V-A</b> POWER CHUCK FOR VERTICAL LATHE Non-Thru-Hole 3-Jaw 31</p>

## Special Purpose Power Chucks

 <p>Pull Lock <b>3D</b> PULL LOCK POWER CHUCK Non-Thru-Hole 3-Jaw 33</p>	 <p>Pull Lock <b>2D</b> PULL LOCK POWER CHUCK Non-Thru-Hole 2-Jaw 34</p>	 <p>Pull Lock <b>3U</b> PULL LOCK POWER CHUCK Thru-Hole 3-Jaw 35</p>
 <p>Pull Lock <b>3U-K</b> PULL LOCK POWER CHUCK Non-Thru-Hole 3-Jaw 36</p>	 <p>Expansible Pull Lock <b>3E</b> EXPANSIBLE PULL LOCK POWER CHUCK Non-Thru-Hole 3-Jaw 37</p>	 <p>Inclined Master Jaw <b>3N</b> INCLINED MASTER JAWS POWER CHUCK Non-Thru-Hole 3-Jaw 38</p>
 <p>Finger Type <b>3J</b> FINGER POWER CHUCK Non-Thru-Hole 3-Jaw 39</p>	 <p>Finger Type <b>2J</b> FINGER POWER CHUCK Non-Thru-Hole 2-Jaw 40</p>	 <p>Swing compensation-type <b>3R</b> SWING COMPENSATION- TYPE THREE-JAW CHUCK Non-Thru-Hole 3-Jaw 41</p>
 <p>Swing compensation-type <b>3W</b> SWING TYPE THREE-JAW CHUCK Non-Thru-Hole 3-Jaw 42</p>	 <p>Quick Jaw-Change <b>3Q</b> QUICK JAW-CHANGE CHUCK Thru-Hole 3-Jaw 43</p>	 <p>Four-Jaw Two Motions <b>4T</b> FOUR-JAW TWO MOTION TYPE POWER CHUCK Non-Thru-Hole 4-Jaw 44</p>
 <p>Large Thru-Hole Air Chuck <b>AP</b> LARGE THRU-HOLE AIR CHUCK Thru-Hole 3-Jaw 45</p>	 <p>Power Indexing Chuck <b>IS</b> POWER INDEXING CHUCK 47</p>	

## Collet Chucks



Collet Chuck  
**CL**  
COLLET CHUCK

Thru-Hole

48



Collet Chuck  
**CL-A**  
COLLET CHUCK

Thru-Hole

49



Draw  
**CB/CB-A**  
DRAW COLLET CHUCK

Thru-Hole

50



End Stop  
**CBE**  
ENDSTOP CHUCK WITH  
FULL PASSAGE

Thru-Hole

51



Dead Length  
**CBD**  
DL-DEAD LENGTH CHUCK

Thru-Hole

52



Rubber Grip Collet  
**RG**  
RUBBER GRIP COLLET

Thru-Hole

53

## Stationary Chucks



Thru-Hole Stationary Chuck  
**VH**  
STATIONARY CHUCK  
WITH THRU-HOLE

Thru-Hole 2/3-Jaw

54



Non-Thru-Hole Stationary Chuck  
**VP**  
STATIONARY CHUCK  
WITH NON-THRU-HOLE

Non-Thru-Hole 2/3-Jaw

55



Non-Thru-Hole Stationary Chuck  
**SP**  
STATIONARY CHUCK

Non-Thru-Hole 3-Jaw

56



Pull Back  
**SD**  
STATIONARY PULL  
BACK CHUCK

Non-Thru-Hole 3-Jaw

57



Pull Lock  
**SU**  
STATIONARY PULL  
LOCK CHUCK

Non-Thru-Hole 3-Jaw

58



Pull Back  
**SE**  
STATIONARY PULL BACK  
CHUCK FOR INTERNAL  
GRIPPING

Non-Thru-Hole 3-Jaw

59



Stationary Chuck Base Plate  
**MP4**  
STATIONARY CHUCK  
BASE PLATE

60

## Synchronous Clamps



Crank Type  
**CP**  
SYNCHRONOUS CLAMP

Crank Type

61



# INDEX [ Product Description ]

## Facing Heads



Single-Slide  
**FA**  
SINGLE-SLIDE FACING  
HEAD  
Single-Slide

62



Double-Slide  
**FD**  
DOUBLE-SLIDE FACING  
HEAD  
Double-Slide

63

## Rotary Cylinders



Thru-Hole  
**TK**  
SHORT TYPE ROTATING HYDRAULIC  
CYLINDER WITH THROUGH-HOLE  
AND SAFETY DEVICE  
Short Type Thru-hole Hydraulic

64



Thru-Hole  
**TH**  
ROTATING HYDRAULIC CYLINDER  
WITH THROUGH-HOLE AND  
SAFETY DEVICE  
Short Type Thru-hole Hydraulic

67



Thru-Hole  
**TR**  
SMALL TYPE ROTARY HYDRAULIC  
CYLINDER WITH THROUGH-HOLE  
AND SAFETY DEVICE  
Short Type Thru-hole Hydraulic

68



Non-Thru-Hole  
**RK**  
ROTATING HYDRAULIC  
CYLINDER WITH SAFETY DEVICE  
Non-Thru-Hole Hydraulic

69



Non-Thru-Hole  
**RK-N**  
ROTATING HYDRAULIC  
CYLINDER  
Non-Thru-Hole Hydraulic

70



Non-Thru-Hole  
**RH**  
ROTATING HYDRAULIC  
CYLINDER  
Non-Thru-Hole Hydraulic

71



Non-Thru-Hole  
**RA**  
ROTATING AIR CYLINDER  
Non-Thru-Hole Air

72



Stroke Control  
**RS**  
ROTATING HYDRAULIC CYLINDER  
WITH STROKE CONTROL AND  
SAFETY DEVICE  
Stroke Control Hydraulic

73



Stroke Control  
**RS-N**  
ROTATING HYDRAULIC  
CYLINDER WITH STROKE  
CONTROL  
Stroke Control Hydraulic

74



Coolant Connection  
**RL**  
ROTATING HYDRAULIC CYLINDER  
WITH COOLANT CONNECTION AND  
SAFETY DEVICE  
Coolant Connection

75



Coolant Connection  
**RL-N**  
ROTATING HYDRAULIC CYLINDER  
WITH COOLANT CONNECTION  
Coolant Connection

76



Air Connection  
**RL-AN**  
ROTATING HYDRAULIC CYLINDER  
WITH AIR CONNECTION  
Air connection Hydraulic

77



Compact Style  
**RE**  
COMPACT STYLE HYDRAULIC  
CYLINDER WITH STROKE  
CONTROL AND SAFETY DEVICE  
Compact Style Hydraulic

78



Compact Style  
**RE-A**  
COMPACT STYLE HYDRAULIC CYLINDER  
WITH AIR CONNECTION AND  
SAFETY DEVICE  
Compact Style Hydraulic

80



Compact Style  
**RE-L**  
COMPACT STYLE HYDRAULIC  
CYLINDER WITH COOLANT  
CONNECTION AND SAFETY DEVICE  
Coolant connection

82



Double Rod  
**RD**  
DOUBLE ROD ROTATING  
CYLINDER WITH  
SAFETY DEVICE  
Double Rod Hydraulic

84



Double Rod  
**RD-N**  
DOUBLE ROD ROTATING  
CYLINDER  
Double Rod Hydraulic

85



For Gear Machine  
**RG**  
ROTATING HYDRAULIC  
CYLINDER FOR GEAR  
MACHINES  
For Gear Machine

86

## Rotary Valve/ Rotary Joint



Rotary Valve  
**RV**  
HYDRAULIC ROTARY VALVE

Oil Circuit Distributor  
Hydraulic

87



Rotary Valve  
**RV-A**  
AIR ROTARY VALVE

Air

87



Coolant Joint  
**RJ-80**  
COOLANT ROTATING  
JOINT

Coolant Joint

88



Coolant Joint  
**RJ-90**  
COOLANT ROTATING  
JOINT WITH AUTOMATIC  
ON/OFF SEAL

Coolant Joint

88

## Parts and Accessories



Standard Soft Jaw  
**SJ**  
STANDARD SOFT BLANK  
JAW

Standard Jaw

89



Standard Hard Jaws  
**HJ**  
STANDARD HARD JAW

Standard Jaw

92



Spring Collet  
**DIN 6343**  
STEEL COLLETS

Spring Collet

93



T-Nut  
**T-Nut**  
T-NUT

T-Nut

94



Chuck Adaptors  
**FL**  
CHUCK ADAPTORS

Chuck Adaptors

95



Coolant Collector  
**CT**  
COOLANT COLLECTOR  
WITH STROKE CONTROL

Coolant Collector

96



Latching Valves  
**FV-01**  
STATIONARY CYLINDER  
LOCK VALVE FOR  
AIR STATIONARY CHUCK

Accessories

97



Switch Valves  
**VH-201**  
HAND OPERATED  
AIR VALVE

Accessories

97

THE CALCULATION OF  
DRAW TUBE LENGTH

98

THE CALCULATION OF  
DRAW BAR LENGTH

99





### Application/customer benefits

- 3-Jaw WEDGE style with a large thru-hole
- All mating surfaces and internal parts are hardened, ground and lubricated
- High rigidity and clamping accuracy
- J value is the hole diameter of blank draw nut, K is the maximum thread specification, and it could be customized

3H-08A5  
3H-10A6  
3H-15A8

Refer to Fig.A

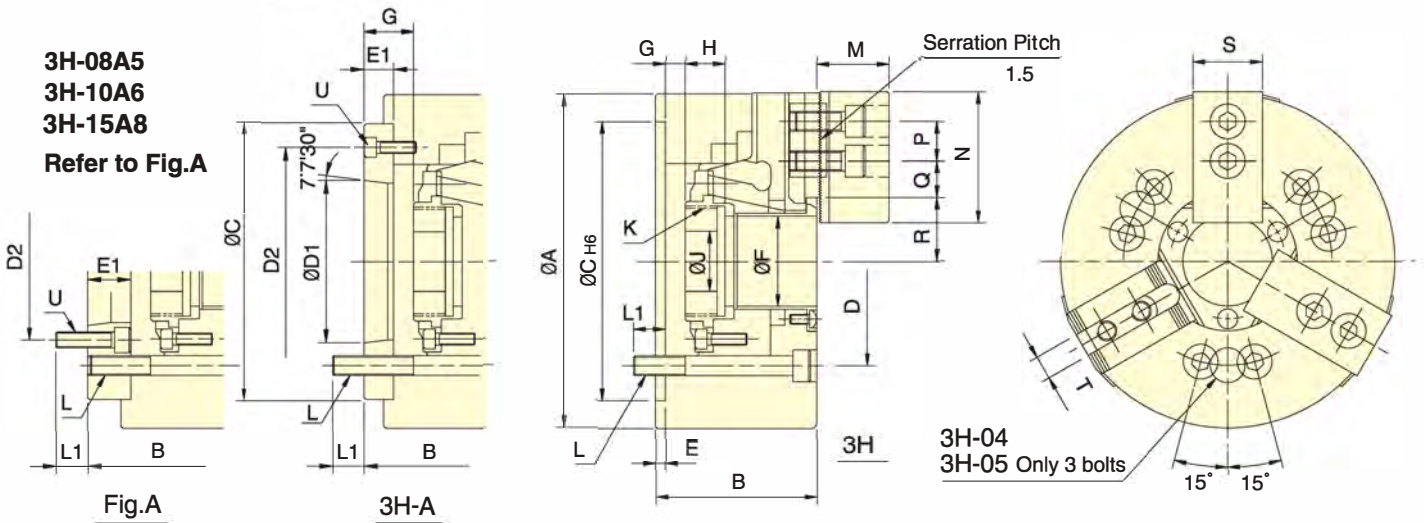

### Specifications

Model	Plunger stroke (mm)	Jaw stroke (Dia.) (mm)	Chucking Dia. Max. (mm)	Chucking Dia. Min. (mm)	Max. D.B. pull kN (kgf)	Max. clamping force kN (kgf)	Max. speed min <sup>-1</sup> (r.p.m.)	l kg · m <sup>2</sup>	Weight (kg)	Matching cyl.	Max. pressure MPa (kgf/cm <sup>2</sup> )	
3H-04	10	5.4	110	7	13.7(1400)	28.4(2900)	8000	0.01	4	TK-A533	2.0(20)	
3H-05	A4	5.4	135	12	17.1(1750)	35.8(3650)	7000	0.02	6.7	7.5	TK-A533	2.5(25)
3H-06	A5	5.5	168	15	21.5(2200)	56.8(5800)	6000	0.06	11.9	13.7	TK-C646	2.5(25)
3H-08	A5	7.4	210	13	34.3(3500)	85.8(8750)	5000	0.18	22.5	25.4	TK-A853	2.8(28)
3H-08	A6	7.4	210	13	34.3(3500)	85.8(8750)	5000	0.18	22.5	23.6	TK-A853	2.8(28)
3H-10	A6	8.8	254	25	42.6(4380)	110.7(11300)	4200	0.33	34.5	41.5	TK-1075	2.9(29)
3H-10	A8	8.8	254	25	42.6(4380)	110.7(11300)	4200	0.33	34.5	40	TK-1075	2.9(29)
3H-12	A8	10.6	304	34	54.9(5600)	143.6(14650)	3300	0.77	56.6	59.5	TK-A1291	2.5(26)
3H-15	A8	10.6	381	50	71(7250)	179.8(18350)	2500	2.47	120	134	TK-1512	2.1(22)
3H-15	A11	10.6	381	50	71(7250)	179.8(18350)	2500	2.39	120	127	TK-1512	2.1(22)
3H-18	A11	10.6	450	50	71(7250)	179.8(18350)	2000	4.78	164	178	TK-1512	2.1(22)

### Dimensions

Model	A	B	B	C	D	D1	D2	E	E1	F	G max.	G max.	G min.	G min.	H	J	K max.	L	L1	L1	M	N	P	Q max.	Q min.	R max.	R min.	S	T	U	
3H-04	110	59	-	85	70.6	-	-	4	-	26	3.5	-	-6.5	-	17.5	12	M32x1.5	3~M10	16	-	24	52	14	11.3	6.8	23	20.3	23	10	-	
3H-05	A4	135	60	71	110	82.6	63.51	96	4	15	33	1	16	-9	6	20	12	M40x1.5	3~M10	15	15	31	62	14	21.8	8.3	26.5	23.8	25	10	3~M6
3H-06	A5	168	81	91	140	104.8	82.56	116	5	15	45	11	26	-1	14	19	20	M55x2	6~M10	16	16	37	73	20	22.8	9.3	32	29.3	31	12	3~M6
3H-08	A5	210	91	109	170	133.4	82.56	104.8	5	23	52	14.5	37.5	-1.5	21.5	20.5	30	M60x2	6~M12	20	17	38	95	25	29.8	14.8	38.7	35	35	14	6~M10
3H-08	A6	210	91	103	170	133.4	106.38	150	5	17	52	14.5	31.5	-1.5	15.5	20.5	30	M60x2	6~M12	20	18	38	95	25	29.8	14.8	38.7	35	35	14	3~M6
3H-10	A6	254	100	120	220	171.4	106.38	133.4	5	25	75	8.5	33.5	-10.5	14.5	25	45	M85x2	6~M16	22	18	43	110	30	33.8	14.3	51	46.6	40	16	6~M12
3H-10	A8	254	100	113	220	171.4	139.72	190	5	18	75	8.5	26.5	-10.5	7.5	25	45	M85x2	6~M16	22	24	43	110	30	33.8	14.3	51	46.6	40	16	3~M8
3H-12	A8	304	110	122	220	171.4	139.72	190	6	18	91	8	26	-15	3	28	50	M100x2	6~M16	23	25	51	130	30	45.8	15.8	61.3	56	50	21	3~M8
3H-15	A8	381	133	160	300	235	139.72	171.4	6	33	120	11	44	-12	21	39	60	M130x2	6~M20	30	24	63	165	43	47.5	20.5	80	74.7	62	25.5 or 22	6~M16
3H-15	A11	381	133	149	300	235	196.87	260	6	22	120	11	33	-12	10	39	60	M130x2	6~M20	30	28	63	165	43	47.5	20.5	80	74.7	62	25.5 or 22	3~M10
3H-18	A11	450	133	149	300	235	196.87	260	6	22	120	11	33	-12	10	39	60	M130x2	6~M20	30	28	63	165	43	83.5	20.5	80	74.7	62	25.5 or 22	3~M10

The dimensions and the specifications of 3H-A type are in the red data.



### Application/customer benefits

- 3-Jaw WEDGE style with extra-large thru-hole
- All mating surfaces and internal parts are hardened, ground and lubricated
- High rigidity and clamping accuracy
- J value is the hole diameter of blank draw nut, K is the maximum thread specification, and it could be customized

### 3H-24BA15

Refer to Fig. A

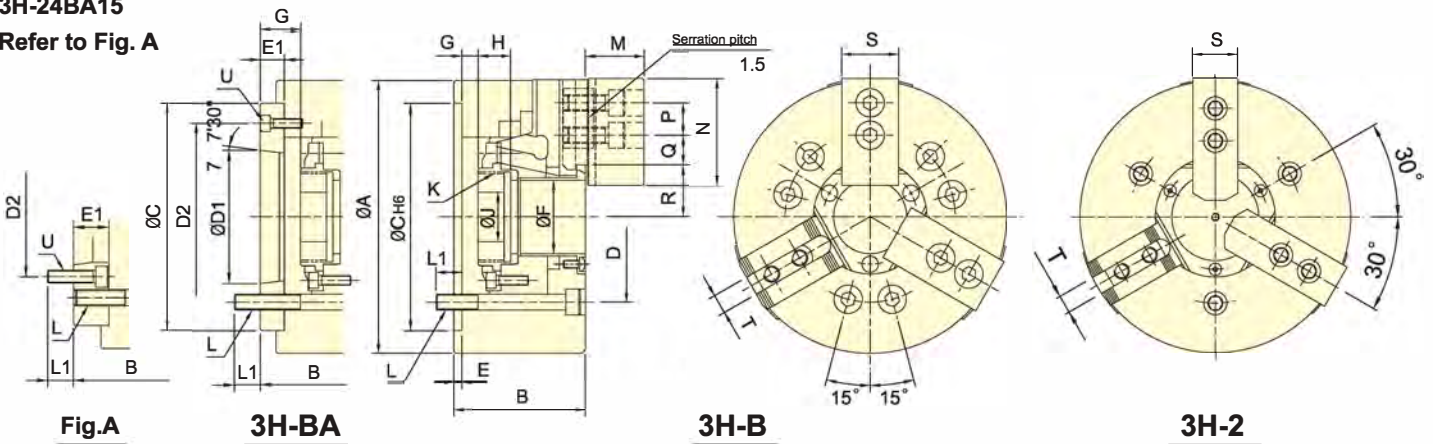

### Specifications

Model	Plunger stroke (mm)	Jaw stroke (Dia.) (mm)	Chucking Dia. Max. (mm)	Chucking Dia. Min. (mm)	Max. D.B. pull kN (kgf)	Max. clamping force kN (kgf)	Max. speed min <sup>-1</sup> (r.p.m.)	l kg · m <sup>2</sup>	Weight (kg)	Matching cyl.	Max. pressure MPa (kgf/cm <sup>2</sup> )	
3H-204 A4	13	5.5	118	7	13.7(1400)	36(3670)	8000	0.012	4.2	4.8	TK-A533	2.0(20)
3H-205 A4	13	5.5	138	12	17.2(1750)	48(4890)	7000	0.02	6.3	7.1	TK-A533	2.5(25)
3H-206 A5	14	6	170	18	23.3(2375)	66.8(6810)	6000	0.06	13.1	14.9	TK-A853	1.9(19)
3H-208 A6	18	7.6	210	23	31.9(3250)	107(10900)	5000	0.15	21.8	23.4	TK-1068	2.2(22)
3H-10B A8	19	8.8	260	46	49.1(5010)	126.9(12950)	4500	0.32	33.2	38.7	TK-1287	2.6(26)
3H-12B A11	23	10.6	315	47	58.8(6000)	152.9(15600)	3500	0.73	51	58	TK-1511	2.0(20)
3H-15B A15	23	10.6	405	60	71(7240)	180(18350)	2500	2.3	127.8	138.8	TK-2114	2.4(24)
3H-18B A15	23	10.6	456	66	71(7240)	180(18350)	2000	4.8	162.4	173.4	TK-2416	2.2(22)
3H-21B A15	23	10.6	530	104	89.9(9175)	233.8(23860)	1700	7.5	223	234	TK-2820	2.1(21)
3H-24B A15	26	12	610	128	89.9(9175)	233.8(23860)	1400	14.8	270	315	TK-2820	2.1(21)
3H-24B A20	26	12	610	128	89.9(9175)	233.8(23860)	1400	14.8	270	284	TK-2820	2.1(21)

### Dimensions

Model	A	B	B	C	D	D1	D2	E	E1	F	G max.	G max.	G min.	G min.	H	J	K max.	L	L1	L1	M	N	P	Q max.	Q min.	R max.	R min.	S	T	U
3H-204 A4	118	59	70	110	82.6	63.51	96	4	15	33	3.5	18.5	-9.5	5.5	17.5	12	M40x1.5	3~M10	16	16	24	52	14	14.2	5.3	26	23.25	23	10	3~M6
3H-205 A4	138	60	71	110	82.6	63.51	96	4	15	39	1	16	-12	3	20	12	M45x1.5	3~M10	15	15	31	62	14	20.25	6.75	29.5	26.75	25	10	3~M6
3H-206 A5	170	81	91	140	104.8	82.56	116	5	15	53	13	28	-1	14	17.5	20	M60x2	3~M10	16	11	37	73	20	21.22	12.22	36	33	31	12	3~M6
3H-208 A6	210	91	103	170	133.4	106.38	150	5	17	66	16.5	33.5	-1.5	15.5	20	30	M75x2	3~M12	17	15	38	95	25	23.72	13.22	45.7	41.9	35	14	3~M6
3H-10B A8	260	100	113	220	171.5	139.72	190	5	18	86	8.5	26.5	-10.5	7.5	25	45	M95x2	6~M16	22	24	43	110	30	32.25	14.25	56	51.6	40	16	3~M8
3H-12B A11	315	110	126	300	235	196.87	260	6	22	106	8	30	-15	7	28	50	M115x2	6~M20	30	28	51	130	30	45.75	15.75	68.8	63.5	50	21	3~M10
3H-15B A15	405	133	154	380	330.2	285.78	330.2	6	27	140	11	38	-12	15	39	45	M155x3	6~M24	35	38	63	165	43	43.75	18.25	91	85.7	62	25.5	3~M12
3H-18B A15	456	145	166	380	330.2	285.78	330.2	6	27	165	18	45	-5	22	40	60	M175x3	6~M24	38	36	63	165	43	65.25	18.75	102	96.7	62	25.5	3~M12
3H-21B A15	530	140	161	380	330.2	285.78	330.2	6	27	180	11	38	-12	15	39	80	M190x3	6~M24	35	38	73	180	60	69.5	21.5	113.5	108.2	65	25	3~M12
3H-24B A15	610	147	181	520	463.6	285.78	330.2	6	40	205	18	58	-8	32	40	120	M215x3	6~M24	35	35	73	180	60	93.5	21.5	126	120	65	25	6~M24
3H-24B A20	610	147	168	520	463.6	412.78	463.6	6	27	205	18	45	-8	19	40	120	M215x3	6~M24	35	38	73	180	60	93.5	21.5	126	120	65	25	3~M12

The dimensions and the specifications of 3H-BA type are in the red data.





### Application/customer benefits

- 2-Jaw WEDGE style with large thru-hole
- All mating surfaces and internal parts are hardened, ground and lubricated
- High rigidity and clamping accuracy
- J value is the hole diameter of blank draw nut, K is the maximum thread specification, and it could be customized

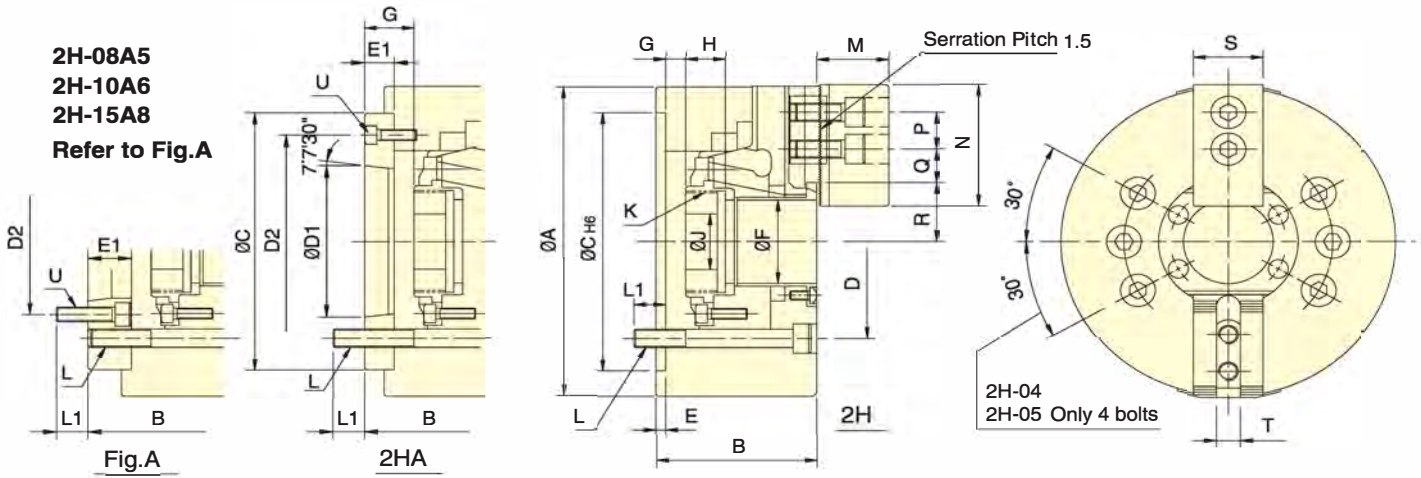

### Specifications

Model	Plunger stroke (mm)	Jaw stroke (Dia.) (mm)	Chuck Dia. Max. (mm)	Chuck Dia. Min. (mm)	Max. D.B. pull kN (kgf)	Max. clamping force kN (kgf)	Max. speed min <sup>-1</sup> (r.p.m.)	I kg · m <sup>2</sup>	Weight (kg)	Matching cyl.	Max. pressure MPa (kgf/cm <sup>2</sup> )
2H-04	10	5.4	110	7	9.2(940)	18.9(1930)	8000	0.01	3.8	TK-A533	1.4(14)
2H-05	<b>A4</b>	5.4	135	12	11.7(1190)	23.9(2440)	7000	0.02	6.5 <b>7.3</b>	TK-A533	1.7(17)
2H-06	<b>A5</b>	5.5	168	15	14.4(1470)	37.9(3870)	6000	0.06	11.5 <b>13.3</b>	TK-C646	1.7(17)
2H-08	<b>A5</b>	7.4	210	13	23.1(2360)	57.2(5840)	5000	0.17	21.3 <b>24.2</b>	TK-A853	1.9(19)
2H-08	<b>A6</b>	7.4	210	13	23.1(2360)	57.2(5840)	5000	0.17	21.3 <b>22.4</b>	TK-A853	1.9(19)
2H-10	<b>A6</b>	8.8	254	31	28.4(2900)	73.9(7540)	4200	0.31	33.5 <b>40.5</b>	TK-1075	1.9(19)
2H-10	<b>A8</b>	8.8	254	31	28.4(2900)	73.9(7540)	4200	0.31	33.5 <b>39</b>	TK-1075	1.9(19)
2H-12	<b>A8</b>	10.6	304	34	36.7(3740)	95.8(9780)	3300	0.7	59.7 <b>62.7</b>	TK-A1291	1.7(17)
2H-15	<b>A8</b>	10.6	381	50	46.9(4790)	119.6(12200)	2500	2.42	115 <b>129</b>	TK-1512	1.4(14)
2H-15	<b>A11</b>	10.6	381	50	46.9(4790)	119.6(12200)	2500	2.34	115 <b>122</b>	TK-1512	1.4(14)

### Dimensions

Model	A	B	B	C	D	D1	D2	E	E1	F	G max.	G min.	G min.	H	J	K max.	L	L1	L1	M	N	P	Q max.	Q min.	R max.	R min.	S	T	U		
2H-04	110	59	-	85	70.6	-	-	4	-	26	3.5	-	-6.5	-	17.5	12	M32x1.5	4~M10	16	-	24	52	14	11.3	6.8	23	20.3	23	10	-	
2H-05	<b>A4</b>	135	60	<b>71</b>	110	82.6	<b>63.51</b>	<b>96</b>	4	<b>15</b>	<b>33</b>	<b>1</b>	<b>16</b>	<b>-9</b>	<b>6</b>	20	12	M40x1.5	4~M10	15	<b>15</b>	31	62	14	19.8	7.8	26.5	23.8	25	10	<b>3~M6</b>
2H-06	<b>A5</b>	168	81	<b>91</b>	140	104.8	<b>82.56</b>	<b>116</b>	5	<b>15</b>	45	11	<b>26</b>	<b>-1</b>	<b>14</b>	19	20	M55x2	6~M10	16	<b>16</b>	37	73	20	22.8	9.3	32	29.3	31	12	<b>3~M6</b>
2H-08	<b>A5</b>	210	91	<b>109</b>	170	133.4	<b>82.56</b>	<b>104.8</b>	5	<b>23</b>	52	14.5	<b>37.5</b>	<b>-1.5</b>	<b>21.5</b>	20.5	30	M60x2	6~M12	20	<b>17</b>	38	95	25	29.8	14.8	38.7	35	35	14	<b>6~M10</b>
2H-08	<b>A6</b>	210	91	<b>103</b>	170	133.4	<b>106.38</b>	<b>150</b>	5	<b>17</b>	52	14.5	<b>31.5</b>	<b>-1.5</b>	<b>15.5</b>	20.5	30	M60x2	6~M12	20	<b>18</b>	38	95	25	29.8	14.8	38.7	35	35	14	<b>3~M6</b>
2H-10	<b>A6</b>	254	100	<b>120</b>	220	171.4	<b>106.38</b>	<b>133.4</b>	5	<b>25</b>	75	8.5	<b>33.5</b>	<b>-10.5</b>	<b>14.5</b>	25	45	M85x2	6~M16	22	<b>18</b>	43	110	30	33.8	14.3	51	46.6	40	16	<b>6~M12</b>
2H-10	<b>A8</b>	254	100	<b>113</b>	220	171.4	<b>139.72</b>	<b>190</b>	5	<b>18</b>	75	8.5	<b>26.5</b>	<b>-10.5</b>	<b>7.5</b>	25	45	M85x2	6~M16	22	<b>24</b>	43	110	30	33.8	14.3	51	46.6	40	16	<b>3~M8</b>
2H-12	<b>A8</b>	304	110	<b>122</b>	220	171.4	<b>139.72</b>	<b>190</b>	6	<b>18</b>	91	8	<b>26</b>	<b>-15</b>	<b>3</b>	28	50	M100x2	6~M16	23	<b>25</b>	51	130	30	45.8	15.8	61.3	56	50	21	<b>3~M8</b>
2H-15	<b>A8</b>	381	133	<b>160</b>	300	235	<b>139.72</b>	<b>171.4</b>	6	<b>33</b>	120	11	<b>44</b>	<b>-12</b>	<b>21</b>	39	60	M130x2	6~M20	30	<b>24</b>	63	165	43	47.3	18.2	80	74.7	62	25.5 or 22	<b>6~M16</b>
2H-15	<b>A11</b>	381	133	<b>149</b>	300	235	<b>196.87</b>	<b>260</b>	6	<b>22</b>	120	11	<b>33</b>	<b>-12</b>	<b>10</b>	39	60	M130x2	6~M20	30	<b>28</b>	63	165	43	47.3	18.2	80	74.7	62	25.5 or 22	<b>3~M10</b>

The dimensions and the specifications of 2H-A type are in the red data.



### Application/customer benefits

- 4-Jaw WEDGE style with large thru-hole
- All mating surfaces and internal parts are hardened, ground and lubricated
- High rigidity and clamping accuracy
- J value is the hole diameter of blank draw nut, K is the maximum thread specification, and it could be customized

4H-08A5  
4H-10A6  
4H-15A8  
Refer to Fig.A

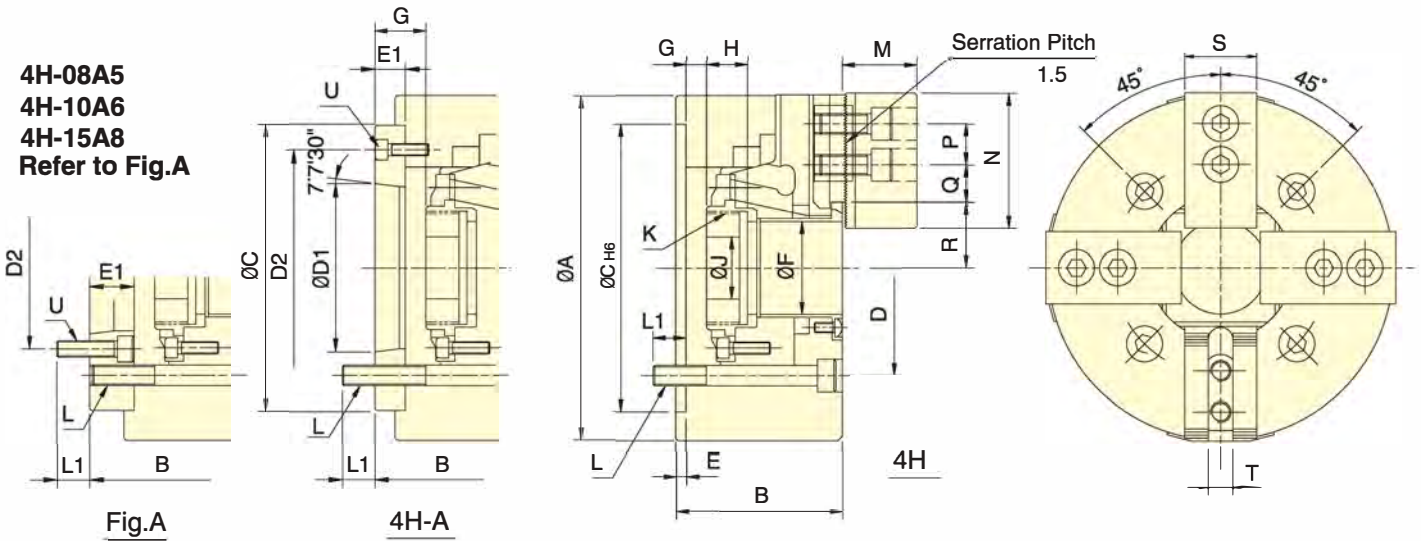

### Specifications

Model	Plunger stroke (mm)	Jaw stroke (Dia.) (mm)	Chucking Dia. Max. (mm)	Chucking Dia. Min. (mm)	Max. D.B. pull kN (kgf)	Max. clamping force kN (kgf)	Max. speed min <sup>-1</sup> (r.p.m.)	I kg · m <sup>2</sup>	Weight (kg)	Matching cyl.	Max. pressure MPa (kgf/cm <sup>2</sup> )		
4H-06	A5	12	5.5	168	15	21.6(2200)	56.8(5600)	5000	0.07	12.5	14.3	TK-C646	2.5(25)
4H-08	A5	16	7.4	210	13	34.3(3500)	85.8(8750)	4200	0.19	23.5	25.4	TK-A853	2.8(28)
4H-08	A6	16	7.4	210	13	34.3(3500)	85.8(8750)	4200	0.19	23.5	24.3	TK-A853	2.8(28)
4H-10	A6	19	8.8	254	25	42.6(4380)	110.7(11300)	3400	0.34	36.3	41	TK-1075	2.9(29)
4H-10	A8	19	8.8	254	31	42.6(4380)	110.7(11300)	3400	0.34	36.3	39.3	TK-1075	2.9(29)
4H-12	A8	23	10.6	304	34	54.9(5600)	143.6(14650)	2700	0.79	62	65.7	TK-A1291	2.6(26)
4H-15	A8	23	10.6	381	50	71(7250)	179.8(18350)	2000	2.5	123.7	137.7	TK-1512	2.2(22)
4H-15	A11	23	10.6	381	50	71(7250)	179.8(18350)	2000	2.42	123.7	130.7	TK-1512	2.2(22)
4H-18	A11	23	10.6	450	50	71(7250)	179.8(18350)	1700	4.85	170	184	TK-1512	2.2(22)

### Dimensions

Model	A	B	B	C	Dj	Dt	D2	E	E1	F	G max.	G max.	G min.	G min.	H	J	K max.	L	L1	L1	M	N	P	Q max.	Q min.	R max.	R min.	S	T	U	
4H-06	A5	168	81	91	140	104.8	82.56	116	5	15	45	11	26	-1	14	19	20	M55x2	4~M10	16	16	37	73	20	22.8	9.3	32	29.3	31	12	3~M6
4H-08	A5	210	91	109	170	133.4	82.56	104.8	5	23	52	14.5	37.5	-1.5	21.5	20.5	30	M60x2	4~M12	20	17	38	95	25	29.8	14.8	38.7	35	35	14	6~M10
4H-08	A6	210	91	103	170	133.4	106.38	150	5	17	52	14.5	31.5	-1.5	15.5	20.5	30	M60x2	4~M12	20	18	38	95	25	29.8	14.8	38.7	35	35	14	3~M6
4H-10	A6	254	100	120	220	171.4	106.38	133.4	5	25	75	8.5	33.5	-10.5	14.5	25	45	M85x2	4~M16	22	18	43	110	30	33.8	14.3	51	46.6	40	16	6~M12
4H-10	A8	254	100	113	220	171.4	139.72	190	5	18	75	8.5	26.5	-10.5	7.5	25	45	M85x2	4~M16	22	24	43	110	30	33.8	14.3	51	46.6	40	16	3~M8
4H-12	A8	304	110	122	220	171.4	139.72	190	6	18	91	8	26	-15	3	28	50	M100x2	4~M16	23	25	51	130	30	45.8	15.8	61.3	56	50	21	3~M8
4H-15	A8	381	133	160	300	235	139.72	171.4	6	33	120	11	44	-12	21	39	60	M130x2	4~M20	30	24	63	165	43	47.5	20.5	80	74.7	62	25.5 or 22	6~M16
4H-15	A11	381	133	149	300	235	196.87	260	6	22	120	11	33	-12	10	39	60	M130x2	4~M20	30	28	63	165	43	47.5	20.5	80	74.7	62	25.5 or 22	3~M10
4H-18	A11	450	133	149	300	235	196.87	260	6	22	120	11	33	-12	10	39	60	M130x2	4~M20	30	28	63	165	43	83.5	20.5	80	74.7	62	25.5 or 22	3~M10

The dimensions and the specifications of 4H-A type are in the red data.





### Application/customer benefits

- 3-Jaw WEDGE-style Closed Center
- All mating surfaces and internal parts are hardened, ground and lubricated
- High rigidity and clamping accuracy

**3P-08A5  
3P-10A6  
3P-12A6**  
Refer to Fig.A

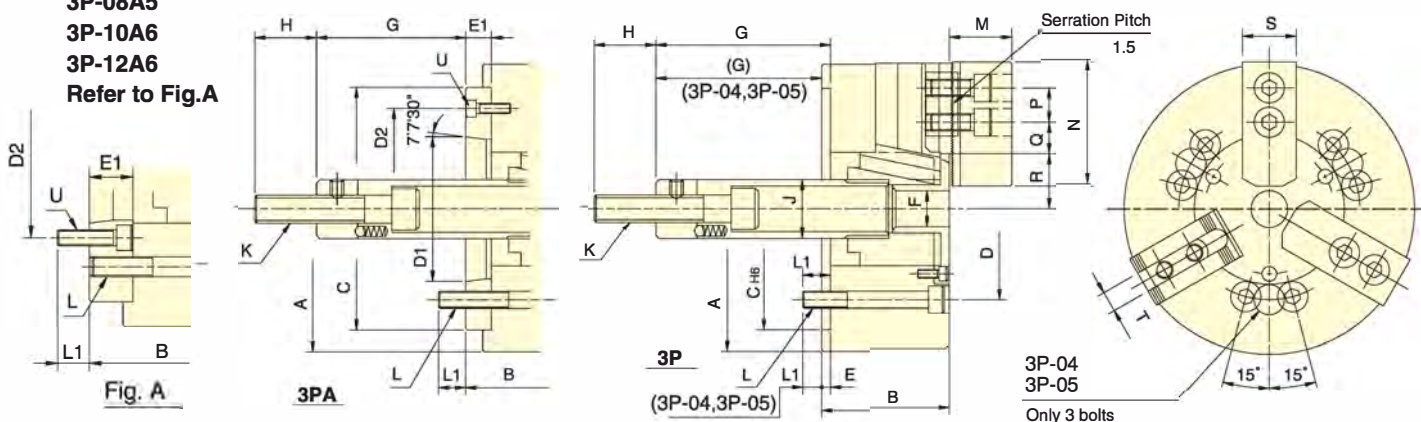

### Specifications

Model	Plunger stroke (mm)	Jaw stroke (Dia.) (mm)	Chucking Dia. Max. (mm)	Chucking Dia. Min. (mm)	Max. D.B. pull kN (kgf)	Max. clamping force kN (kgf)	Max. speed min <sup>†</sup> (r.p.m.)	I kg · m <sup>2</sup>	Weight (kg)	Matching cyl.	Max. pressure MPa (kgf/cm <sup>2</sup> )
3P-04	15	6.4	110	5	8.1(830)	22.5(2300)	6000	0.01	4.1	RK-75(N) RA-130	2.2(22) 0.6(6)
3P-05	15	6.4	135	14	8.1(830)	25(2550)	5500	0.02	6.2	RK-75(N) RA-130	2.2(22) 0.6(6)
3P-06 <b>A5</b>	20	8.5	165	14	17.9(1830)	52.4(5350)	5250	0.05	13 <b>14</b>	RK-100(N) RA-170	2.6(26) 0.6(6)
3P-08 <b>A5</b>	21	8.8	210	17	25(2550)	74.5(7600)	4750	0.14	24 <b>28</b>	RK-125(N) RA-220	2.3(23) 0.5(5)
3P-08 <b>A6</b>	21	8.8	210	17	25(2550)	74.5(7600)	4750	0.14	24 <b>27</b>	RK-125(N) RA-220	2.3(23) 0.5(5)
3P-10 <b>A6</b>	25	8.8	254	22	28.9(2950)	107.8(11000)	4000	0.3	35 <b>42</b>	RK-125(N) RA-220	2.6(26) 0.6(6)
3P-10 <b>A8</b>	25	8.8	254	22	28.9(2950)	107.8(11000)	4000	0.3	35 <b>40</b>	RK-125(N) RA-220	2.6(26) 0.6(6)
3P-12 <b>A6</b>	30	10.5	304	22	41(4180)	155.8(15900)	3360	0.73	59 <b>65</b>	RK-150(N) RA-270	2.6(26) 0.8(8)
3P-12 <b>A8</b>	30	10.5	304	22	41(4180)	155.8(15900)	3360	0.73	59 <b>63</b>	RK-150(N) RA-270	2.6(26) 0.8(8)

### Dimensions

Model	A	B	B	C	D	D1	D2	E	E1	F	G max.	G max.	G min.	G min.	H	J	K	L	L1	L1	M	N	P	Q max.	Q min.	R max.	R min.	S	T	U
3P-04	110	52	-	60	80	-	-	6	-	-	18	-	3	-	25	26	M10x1.5	3~M8	12	-	24	52	14	11.3	8.3	23.3	20.1	23	10	-
3P-05	135	55	-	80	100	-	-	7	-	-	9	-	-6	-	35	28	M12x1.75	3~M8	14	-	31	62	14	13.5	6	30.4	27.2	25	10	-
3P-06 <b>A5</b>	165	74	<b>84</b>	140	104.8	<b>82.56</b>	<b>116</b>	5	<b>15</b>	21	102.5	<b>87.6</b>	82.6	<b>67.6</b>	35	34	M16x2	6~M10	14	<b>14</b>	37	73	20	18.25	9.25	38.25	34	31	12	3~M6
3P-08 <b>A5</b>	210	85	<b>103</b>	170	133.4	<b>82.56</b>	<b>104.8</b>	5	<b>23</b>	25	127	<b>104</b>	106	<b>83</b>	36	38	M20x2.5	6~M12	20	<b>17</b>	38	95	25	22.3	11.8	46.3	41.9	35	14	6~M10
3P-08 <b>A6</b>	210	85	<b>97</b>	170	133.4	<b>106.38</b>	<b>150</b>	5	<b>17</b>	25	127	<b>110</b>	106	<b>89</b>	36	38	M20x2.5	6~M12	20	<b>18</b>	38	95	25	22.3	11.8	46.3	41.9	35	14	3~M6
3P-10 <b>A6</b>	254	89	<b>109</b>	220	171.4	<b>106.38</b>	<b>133.4</b>	5	<b>25</b>	34	158	<b>133</b>	133	<b>108</b>	36	45	M20x2.5	6~M16	18	<b>18</b>	43	110	30	30.8	11.3	51.1	46.7	40	16	6~M12
3P-10 <b>A8</b>	254	89	<b>102</b>	220	171.4	<b>139.72</b>	<b>190</b>	5	<b>18</b>	34	158	<b>140</b>	133	<b>115</b>	36	45	M20x2.5	6~M16	18	<b>25</b>	43	110	30	30.8	11.3	51.1	46.7	40	16	3~M8
3P-12 <b>A6</b>	304	106	<b>125</b>	220	171.4	<b>106.38</b>	<b>133.4</b>	6	<b>25</b>	34	163	<b>138</b>	133	<b>108</b>	36	50	M20x2.5	6~M16	18	<b>18</b>	51	130	30	48.5	12.5	-	-	50	18 or 21	6~M12
3P-12 <b>A8</b>	304	106	<b>118</b>	220	171.4	<b>139.72</b>	<b>190</b>	6	<b>18</b>	34	163	<b>145</b>	133	<b>115</b>	36	50	M20x2.5	6~M16	18	<b>25</b>	51	130	30	48.5	12.5	-	-	50	18 or 21	3~M8

The dimensions and the specifications of 3P-A type are in the red data.



### Application/customer benefits

- 3-Jaw WEDGE style Closed Center
- All mating surfaces and internal parts are hardened, ground and lubricated
- High rigidity and clamping accuracy

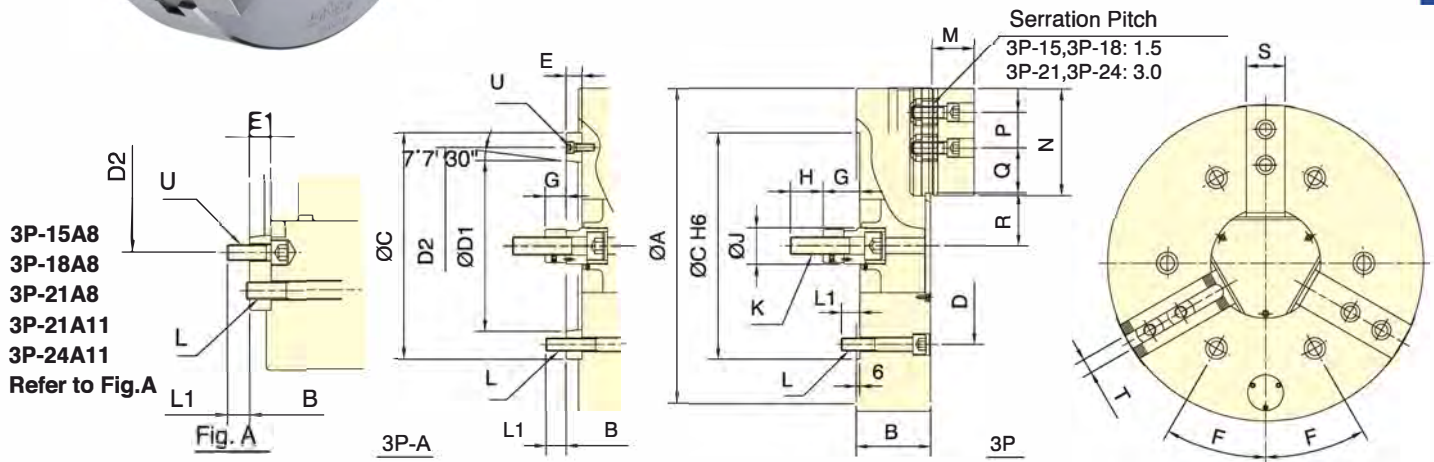

### Specifications

Model	Plunger stroke (mm)	Jaw stroke (Dia.) (mm)	Chucking Dia. Max. (mm)	Chucking Dia. Min. (mm)	Max. D.B. pull kN (kgf)	Max. clamping force kN (kgf)	Max. speed min <sup>-1</sup> (r.p.m.)	<sup>1</sup> kg · m <sup>2</sup>	Weight (kg)	Matching cyl.	Max. pressure MPa (kgf/cm <sup>2</sup> )	
3P-15 <b>A8</b>	35	16	381	50	82(8360)	248.4(25350)	3000	1.95	100	114	RH-200 or RK-200(N)	2.8(28)
3P-15 <b>A11</b>	35	16	381	50	82(8360)	248.4(25350)	3000	1.95	100	107	RH-200 or RK-200(N)	2.8(28)
3P-18 <b>A8</b>	35	16	450	60	82(8360)	248.4(25350)	2700	2.47	131	145	RH-200 or RK-200(N)	2.8(28)
3P-18 <b>A11</b>	35	16	450	60	82(8360)	248.4(25350)	2700	2.47	131	138	RH-200 or RK-200(N)	2.8(28)
3P-21 <b>A8</b>	35	16	530	62	82(8360)	272.6(27800)	1900	4.9	175	196	RH-200 or RK-200(N)	2.8(28)
3P-21 <b>A11</b>	35	16	530	62	82(8360)	272.6(27800)	1900	4.9	175	193	RH-200 or RK-200(N)	2.8(28)
3P-21 <b>A15</b>	35	16	530	62	82(8360)	272.6(27800)	1900	4.9	175	186	RH-200 or RK-200(N)	2.8(28)
3P-24 <b>A11</b>	35	16	610	152	82(8360)	272.6(27800)	1750	7	216	234	RH-200 or RK-200(N)	2.8(28)
3P-24 <b>A15</b>	35	16	610	152	82(8360)	272.6(27800)	1750	7	216	227	RH-200 or RK-200(N)	2.8(28)
*3P-32 <b>A15</b>	35	16	800	152	82(8360)	272.6(27800)	1100	36.2	426	440	RH-200 or RK-200(N)	2.8(28)
*3P-40 <b>A15</b>	35	16	1000	158	82(8360)	272.6(27800)	800	98.5	776	790	RH-200 or RK-200(N)	2.8(28)

### Dimensions

Model	A	B	B	C	D	D1	D2	E	F	G max.	G max.	G min.	G min.	H	J	K	L	L1	L1	M	N	P	Q max.	Q min.	R max.	R min.	S	T	U
3P-15 <b>A8</b>	381	114	141	300	235	139.72	171.4	33	15°	104	71	69	36	55	60	M30x3.5	6~M20	30	29	63	165	43	48.8	23.3	77.5	69.5	62	25.5	6~M16
3P-15 <b>A11</b>	381	114	130	300	235	196.87	260	22	15°	104	82	69	47	55	60	M30x3.5	6~M20	30	33	63	165	43	48.8	23.3	77.5	69.5	62	25.5	3~M10
3P-18 <b>A8</b>	450	114	141	300	235	139.72	171.4	33	15°	92	59	57	24	55	60	M30x3.5	6~M20	30	24	63	165	43	48.8	23.3	108	100	62	25.5	6~M16
3P-18 <b>A11</b>	450	114	130	300	235	196.87	260	22	15°	92	70	57	35	55	60	M30x3.5	6~M20	30	33	63	165	43	48.8	23.3	108	100	62	25.5	3~M10
3P-21 <b>A8</b>	530	125	146	380	330.2	139.72	171.4	27	30°	97	70	62	35	55	60	M30x3.5	6~M24	31	23	73	180	60	90.5	24.5	89	81	65	25	6~M16
3P-21 <b>A11</b>	530	125	146	380	330.2	196.87	235	27	30°	97	70	62	35	55	60	M30x3.5	6~M24	31	28	73	180	60	90.5	24.5	89	81	65	25	6~M20
3P-21 <b>A15</b>	530	125	146	380	330.2	285.78	330.2	27	30°	97	70	62	35	55	60	M30x3.5	6~M24	31	34	73	180	60	90.5	24.5	89	81	65	25	3~M12
3P-24 <b>A11</b>	610	125	146	380	330.2	196.87	235	27	30°	97	70	62	35	55	60	M30x3.5	6~M24	31	28	73	180	60	90.5	24.5	128	120	65	25	6~M20
3P-24 <b>A15</b>	610	125	146	380	330.2	285.78	330.2	27	30°	97	70	62	35	55	60	M30x3.5	6~M24	31	34	73	180	60	90.5	24.5	128	120	65	25	3~M12
*3P-32 <b>A15</b>	800	127	148	380	330.2	285.78	330.2	27	30°	97	70	62	35	55	60	M30x3.5	6~M24	31	34	74.2	180	60	189.5	24.5	128	120	65	25	3~M12
*3P-40 <b>A15</b>	1000	127	148	380	330.2	285.78	330.2	27	30°	97	70	62	35	55	60	M30x3.5	6~M24	31	34	74	180	60	288.5	24.5	128	120	65	25	3~M12

The dimensions and the specifications of 3P-A type are in the red data.  
\*model produced only bu order.





### Application/customer benefits

- It's a WEDGE-HOOK type 3-jaw mini power chuck.
- Matching surfaces of all parts hardened, ground and lubricated directly.
- Suitable for bench lathe.

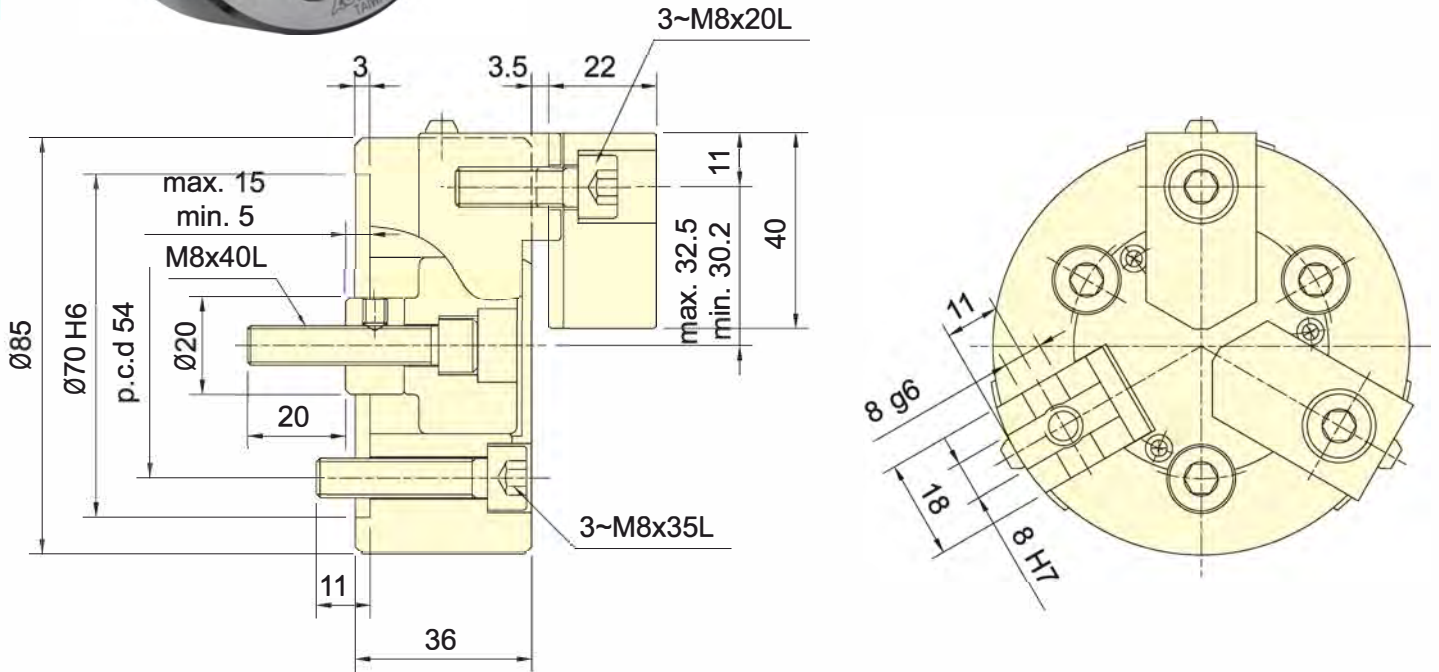

### Specifications

Model	Plunger stroke (mm)	Jaw stroke (Dia.) (mm)	Chucking Dia. Max. (mm)	Chucking Dia. Min. (mm)	Max. D.B. pull kN (kgf)	Max. clamping force kN (kgf)	Max. speed $\text{min}^{-1}$ (r.p.m.)	l kg · m <sup>2</sup>	Weight (kg)	Matching cyl.	Max. pressure MPa(kgf/cm <sup>2</sup> )
3P-03	10	4.6	85	3	4.5(460)	11.3(1150)	7000	0.004	1.8	RK-75	1.2(12.4)

### Standard Soft Jaw For 3P-03 Power Chuck SJ-K03

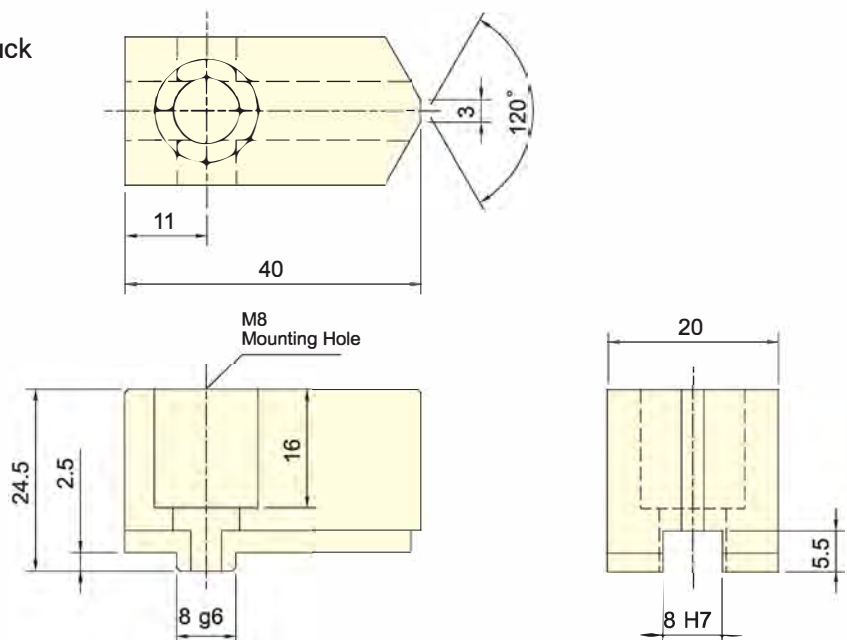



### Application/customer benefits

- 2-Jaw WEDGE style Closed Center
- All mating surfaces and internal parts are hardened, ground and lubricated
- High rigidity and clamping accuracy

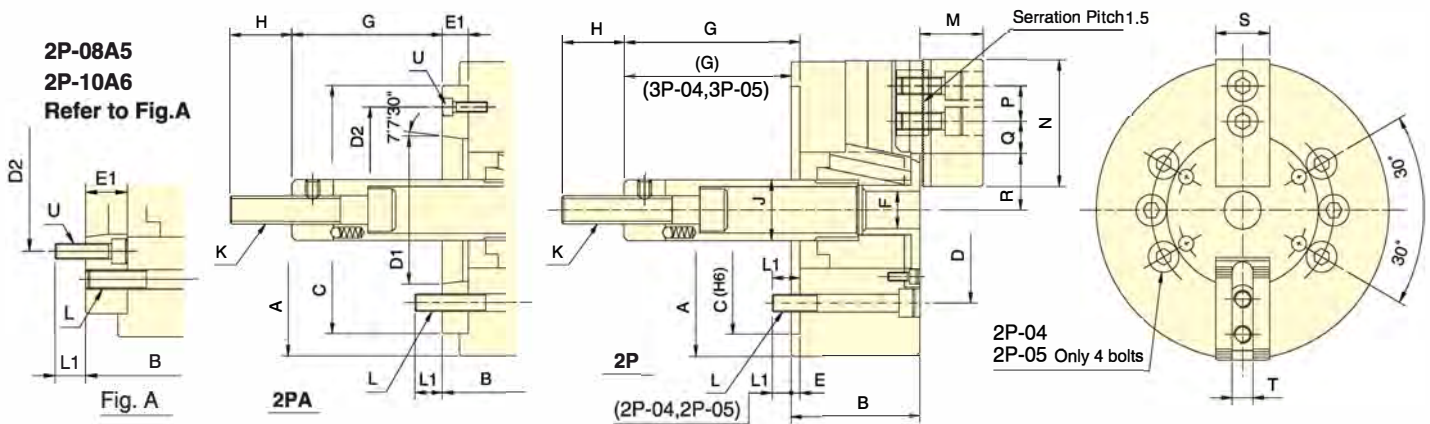

### Specifications

Model	Plunger stroke (mm)	Jaw stroke (Dia.) (mm)	Chucking Dia. Max. (mm)	Chucking Dia. Min. (mm)	Max. D.B. pull kN (kgf)	Max. clamping force kN (kgf)	Max. speed min <sup>-1</sup> (r.p.m.)	I kg · m <sup>2</sup>	Weight (kg)	Matching cyl.	Max. pressure MPa (kgf/cm <sup>2</sup> )
2P-04	15	6.4	110	5	5.3(540)	14.7(1500)	6000	0.01	3.8	RK-75(N) RA-130	1.5(15) 0.4(4)
2P-05	15	6.4	135	14	5.3(540)	16.7(1700)	5500	0.02	5.8	RK-75(N) RA-130	1.5(15) 0.4(4)
2P-06	A5 20	8.5	165	14	12(1220)	35(3570)	5250	0.04	12 13	RK-100(N) RA-170	1.7(17) 0.4(4)
2P-08	A5 21	8.8	210	17	16.5(1680)	50(5100)	4750	0.13	22 26	RK-125(N) RA-220	1.5(15) 0.4(4)
2P-08	A6 21	8.8	210	17	16.5(1680)	50(5100)	4750	0.13	22 25	RK-125(N) RA-220	1.5(15) 0.4(4)
2P-10	A6 25	8.8	254	22	19.4(1980)	71.5(7300)	4000	0.29	33 42	RK-125(N) RA-220	1.8(18) 0.4(4)
2P-10	A8 25	8.8	254	22	19.4(1980)	71.5(7300)	4000	0.29	33 40	RK-125(N) RA-220	1.8(18) 0.4(4)
2P-12	A8 30	10.5	304	22	27.4(2800)	103.9(10600)	3360	0.7	57 61	RK-150(N)	1.7(17)
2P-15	A11 35	16	381	50	54.9(5600)	164.6(16800)	3000	1.7	96 103	RK-200(N)	1.9(19)

### Dimensions

Model	A	B	B	C	D	D1	D2	E	E1	F	G max.	G max.	G min.	G min.	H	J	K	L	L1	L1	M	N	P	Q max.	Q min.	R max.	R min.	S	T	U
2P-04	110	52	-	60	80	-	-	6	-	-	18	-	3	-	25	26	M10x1.5	4~M8	12	-	24	52	14	11.3	8.3	23.3	20.1	23	10	-
2P-05	135	55	-	80	100	-	-	7	-	-	9	-	-6	35	28	M12x1.75	4~M8	14	-	31	62	14	13.5	6	30.4	27.2	25	10	-	
2P-06	A5 165	74	84	140	104.8	82.56	116	5	15	21	102.6	87.6	82.6	67.6	35	34	M16x2	6~M10	14	14	37	73	20	18.25	9.25	38.25	34	31	12	3~M6
2P-08	A5 210	85	103	170	133.4	82.56	104.8	5	23	25	127	104	106	83	36	38	M20x2.5	6~M12	20	17	38	95	25	22.3	11.8	46.3	41.9	35	14	6~M10
2P-08	A6 210	85	97	170	133.4	106.38	150	5	17	25	127	110	106	89	36	38	M20x2.5	6~M12	20	18	38	95	25	22.3	11.8	46.3	41.9	35	14	3~M6
2P-10	A6 254	89	109	220	171.4	106.38	133.4	5	25	34	158	133	133	108	36	45	M20x2.5	6~M16	18	18	43	110	30	30.8	11.3	51.1	46.7	40	16	6~M12
2P-10	A8 254	89	102	220	171.4	139.72	190	5	18	34	158	140	133	115	36	45	M20x2.5	6~M16	18	25	43	110	30	30.8	11.3	51.1	46.7	40	16	6~M8
2P-12	A8 304	106	118	220	171.4	139.72	190	6	18	34	163	145	133	115	36	50	M20x2.5	6~M16	18	25	51	130	30	48.5	12.5	-	-	50	18or21	6~M8
2P-15	A11 381	114	130	300	235	196.87	260	6	22	-	104	82	69	47	55	60	M30x3.5	6~M20	30	33	63	165	43	48.8	23.3	77.5	69.5	62	25.5	3~M10

The dimensions and the specifications of 2P-A type are in the red data.





### Application/customer benefits

- 3-Jaw LEVER style with thru-hole and extra-long jaw stroke
- All mating surfaces and internal parts are hardened, ground and lubricated
- High rigidity and clamping accuracy
- J value is the hole diameter of blank draw nut, K is the maximum thread specification, and it could be customized
- Patent numbers : Taiwan : PAT.207282 / China : PAT.ZL02284637.9

**3L-15A8**  
Refer to Fig.A

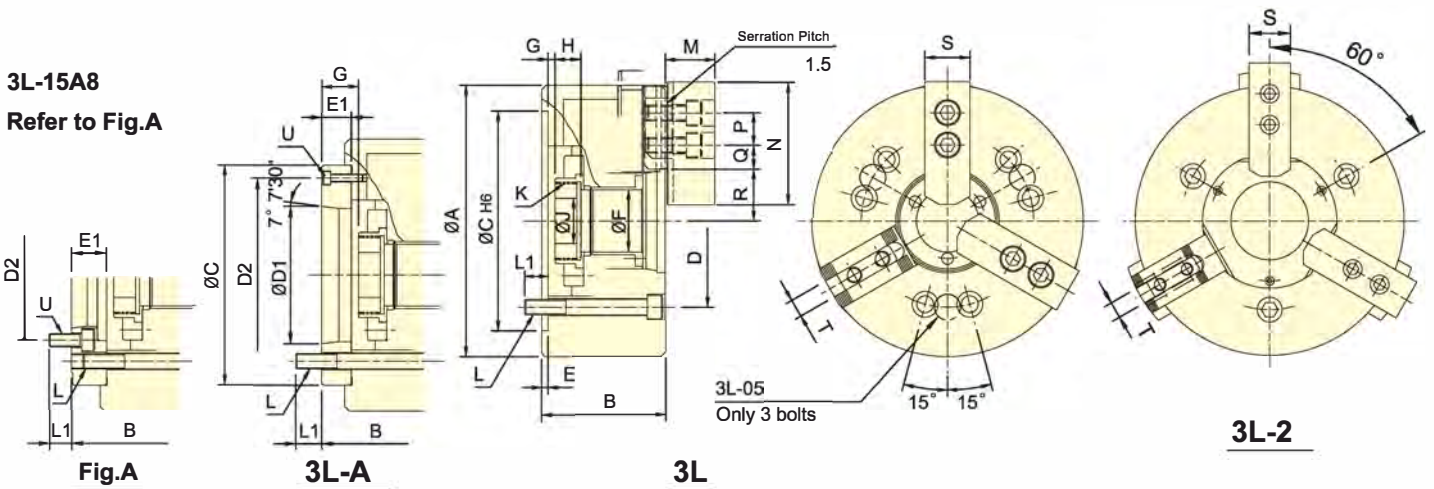

### Specifications

Model	Plunger stroke (mm)	Jaw stroke (Dia.) (mm)	Chucking Dia. Max. (mm)	Chucking Dia. Min. (mm)	Max. D.B. pull kN (kgf)	Max. clamping force kN (kgf)	Max. speed min <sup>-1</sup> (r.p.m.)	I kg · m <sup>2</sup>	Weight (kg)	Matching cyl.	Max. pressure MPa (kgf/cm <sup>2</sup> )	
3L-205 A4	12	18	138	6	15.6(1590)	17.2(1750)	4200	0.019	7.2	8.0	TK-A533	2.3(23)
3L-206 A5	15	24	170	18	23.5(2400)	26(2650)	3600	0.063	13.5	15.3	TK-C646	2.7(27)
3L-208 A5	20	32	215	25	34.3(3500)	40.7(4150)	3000	0.18	24.1	27	TK-A853	2.8(28)
3L-208 A6	20	32	215	25	34.3(3500)	40.7(4150)	3000	0.18	24.1	25.2	TK-A853	2.8(28)
3L-210 A6	25	37.5	260	47	47.7(4870)	55.9(5700)	2400	0.35	39.5	46.5	TK-1075	3.3(33)
3L-210 A8	25	37.5	260	47	47.7(4870)	55.9(5700)	2400	0.35	39.5	45	TK-1075	3.3(33)
3L-212 A8	30	45	315	54	64.7(6600)	61(6220)	2100	0.827	67.3	70.5	TK-A1291	3.0(30)
3L-15 A8	35	52	385	50	84.3(8600)	68(6930)	1600	2.58	136	150	TK-1512	2.6(26)
3L-15 A11	35	52	385	50	84.3(8600)	68(6930)	1600	2.58	136	143	TK-1512	2.6(26)

### Dimensions

Model	A	B	B	C	Dj	D1	D2	E	E1	F	G max.	G max.	G min.	G min.	H	J	K max.	L	L1	L1	M	N	P	Q max.	Q min.	R max.	R min.	S	T	U
3L-205 A4	135	65	76	110	82.6	63.51	96	4	15	32	1	16	-11	4	20	12	M40x1.5	3~M10	15	15	31	62	14	23	9.5	31	22	25	10	3~M6
3L-206 A5	170	84	97	140	104.8	82.56	116	5	18	45	6.5	24.5	-8.5	9.5	19	20	M55x2	3~M10	18	15	37	73	20	15.25	7.75	51	39	31	12	3~M6
3L-208 A5	215	96	114	170	133.4	82.56	104.8	5	23	52	7	30	-13	10	20	30	M60x2	3~M12	18	19	38	95	25	19.25	10.25	63.5	47.5	35	14	6~M10
3L-208 A6	215	96	114	170	133.4	106.38	150	5	23	52	7	30	-13	10	20	30	M60x2	3~M12	18	20	38	95	25	19.25	10.25	63.5	47.5	35	14	3~M6
3L-210 A6	260	108	130	220	171.4	106.38	133.4	5	25	75	8.5	33	-16.5	8	25	45	M85x2	3~M16	25	20	43	110	30	24.75	11.25	80	61.25	40	16	3~M8
3L-210 A8	260	108	121	220	171.4	139.72	190	5	18	75	8.5	26.5	-16.5	1.5	25	45	M85x2	3~M16	25	22	43	110	30	24.75	11.25	80	61.25	40	16	3~M8
3L-212 A8	315	125	138	220	171.4	139.72	190	5	18	91	15	33	-15	3	30	50	M100x2	3~M16	24	21	51	130	30	29.75	13.25	96.5	74	50	21	3~M8
3L-15 A8	385	150	177	300	235	139.72	171.4	6	33	120	12.5	45.5	-22.5	10.5	39	60	M130x2	6~M20	33	31	63	165	43	51.25	27.25	94.25	68.25	62	25.5	6~M16
3L-15 A11	385	150	166	300	235	196.87	260	6	22	120	12.5	34.5	-22.5	-0.5	39	60	M130x2	6~M20	33	31	63	165	43	51.25	27.25	94.25	68.25	62	25.5	3~M10

The dimensions and the specifications of 3L-A type are in the red data.



### Application/customer benefits

- 2-Jaw LEVER style with thru-hole and extra-long jaw stroke
- All mating surfaces and internal parts are hardened, ground and lubricated
- High rigidity and clamping accuracy
- J value is the hole diameter of blank draw nut, K is the maximum thread specification, and it could be customized
- Patent numbers : Taiwan : PAT.207282 / China : PAT.ZL02284637.9

2L-08A5  
2L-10A6  
2L-15A8

Refer to Fig.A

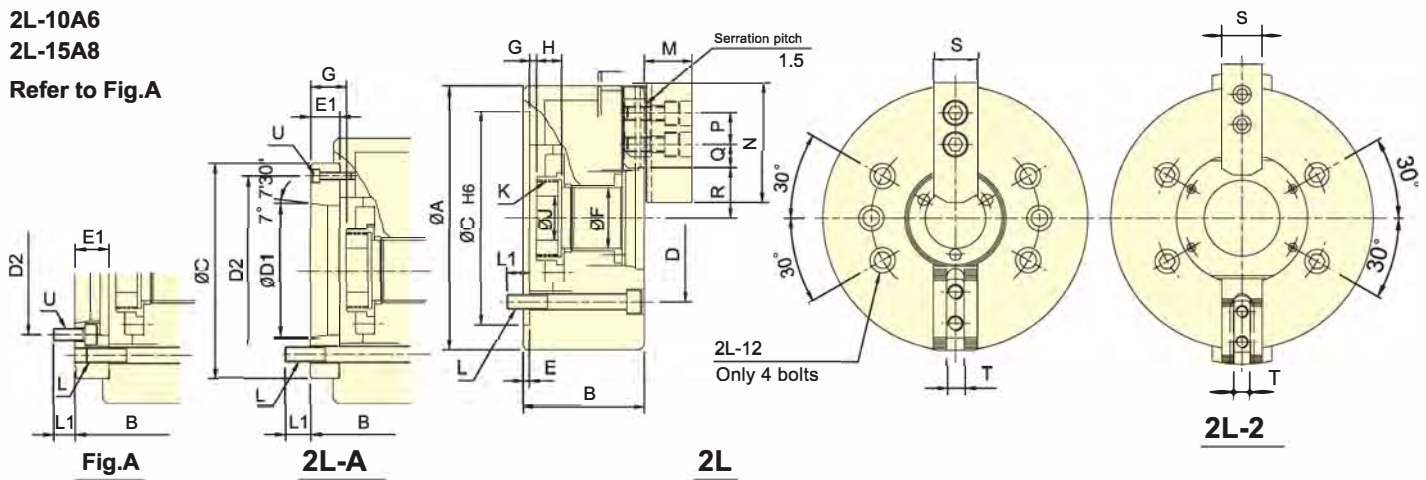

### Specifications

Model	Plunger stroke (mm)	Jaw stroke (Dia.) (mm)	Chucking Dia. Max. (mm)	Chucking Dia. Min. (mm)	Max. D.B. pull kN (kgf)	Max. clamping force kN (kgf)	Max. speed min <sup>-1</sup> (r.p.m.)	I kg · m <sup>2</sup>	Weight (kg)	Matching cyl.	Max. pressure MPa (kgf/cm <sup>2</sup> )	
2L-205 A4	12	18	135	6	10.4(1060)	11.4(1170)	4200	0.018	6.9	7.7	TK-A533	1.5(15)
2L-206 A5	15	24	170	18	15.7(1600)	17.3(1760)	3600	0.063	13.1	14.9	TK-C646	1.8(18)
2L-208 A5	20	32	215	25	22.9(2330)	27.1(2760)	3000	0.173	22	26	TK-A853	1.9(19)
2L-208 A6	20	32	215	25	22.9(2330)	27.1(2760)	3000	0.173	22	24.2	TK-A853	1.9(19)
2L-210 A6	25	37.5	260	47	31.8(3250)	37.3(3800)	2400	0.33	37	45.5	TK-1075	2.5(25)
2L-210 A8	25	37.5	260	47	31.8(3250)	37.3(3800)	2400	0.33	37	44	TK-1075	2.5(25)
2L-12 A8	30	45	304	30	43.1(4400)	50.0(5100)	2100	0.8	60	65.5	TK-A1291	2.0(20)
2L-15 A8	35	52	385	50	56.2(5730)	53.0(5400)	1600	2.52	133	147	TK-1512	1.7(17)
2L-15 A11	35	52	385	50	56.2(5730)	53.0(5400)	1600	2.52	133	140	TK-1512	1.7(17)

### Dimensions

Model	A	B	B	C	D	D1	D2	E	E1	F	G max.	G max.	G min.	G min.	H	J	K	L	L1	L1	M	N	P	Q max.	Q min.	R max.	R min.	S	T	U
2L-205 A4	138	65	76	110	82.6	63.51	96	4	15	32	1	16	-11	4	20	12	M40x1.5	4~M10	15	15	31	62	14	23	13.75	31	22	25	10	3~M6
2L-206 A5	170	84	97	140	104.8	82.56	116	5	18	45	6.5	24.5	-8.5	9.5	19	20	M55x2	4~M10	18	15	37	73	20	15.25	7.75	51	39	31	12	3~M6
2L-208 A5	215	96	114	170	133.4	82.56	104.8	5	23	52	7	30	-13	10	20	30	M60x2	4~M12	18	19	38	95	25	19.25	10.25	63.5	47.5	35	14	6~M10
2L-208 A6	215	96	114	170	133.4	106.38	150	5	23	52	7	30	-13	10	20	30	M60x2	4~M12	18	20	38	95	25	19.25	10.25	63.5	47.5	35	14	3~M6
2L-210 A6	260	108	130	220	171.4	106.38	133.4	5	25	75	8.5	33	-16.5	8	25	45	M85x2	4~M16	25	20	43	110	30	24.75	11.25	80	61.25	40	16	6~M12
2L-210 A8	260	108	121	220	171.4	139.72	190	5	18	75	8.5	26.5	-16.5	1.5	25	45	M85x2	4~M16	25	22	43	110	30	24.75	11.25	80	61.25	40	16	3~M8
2L-12 A8	304	127	140	220	171.4	139.72	190	5	18	91	15	33	-15	3	28	50	M100x2	4~M16	22	19	51	130	30	46.25	19.25	77	54.5	50	21	3~M8
2L-15 A8	385	150	177	300	235	139.72	171.4	6	33	120	12.5	45.5	-22.5	10.5	39	60	M130x2	6~M20	33	27.5	63	165	43	51.25	27.25	94.25	68.25	62	25.5	6~M16
2L-15 A11	385	150	166	300	235	196.87	260	6	22	120	12.5	34.5	-22.5	-0.5	39	60	M130x2	6~M20	33	31	63	165	43	51.25	27.25	94.25	68.25	62	25.5	3~M10

The dimensions and the specifications of 2L-A type are in the red data.





#### Application/customer benefits

- Single-Jaw LEVER style with closed center and extra-long jaw stroke
- All mating surfaces and internal parts are hardened, ground and lubricated
- High rigidity and clamping accuracy

1L-08A5  
1L-10A6  
Refer to Fig.A

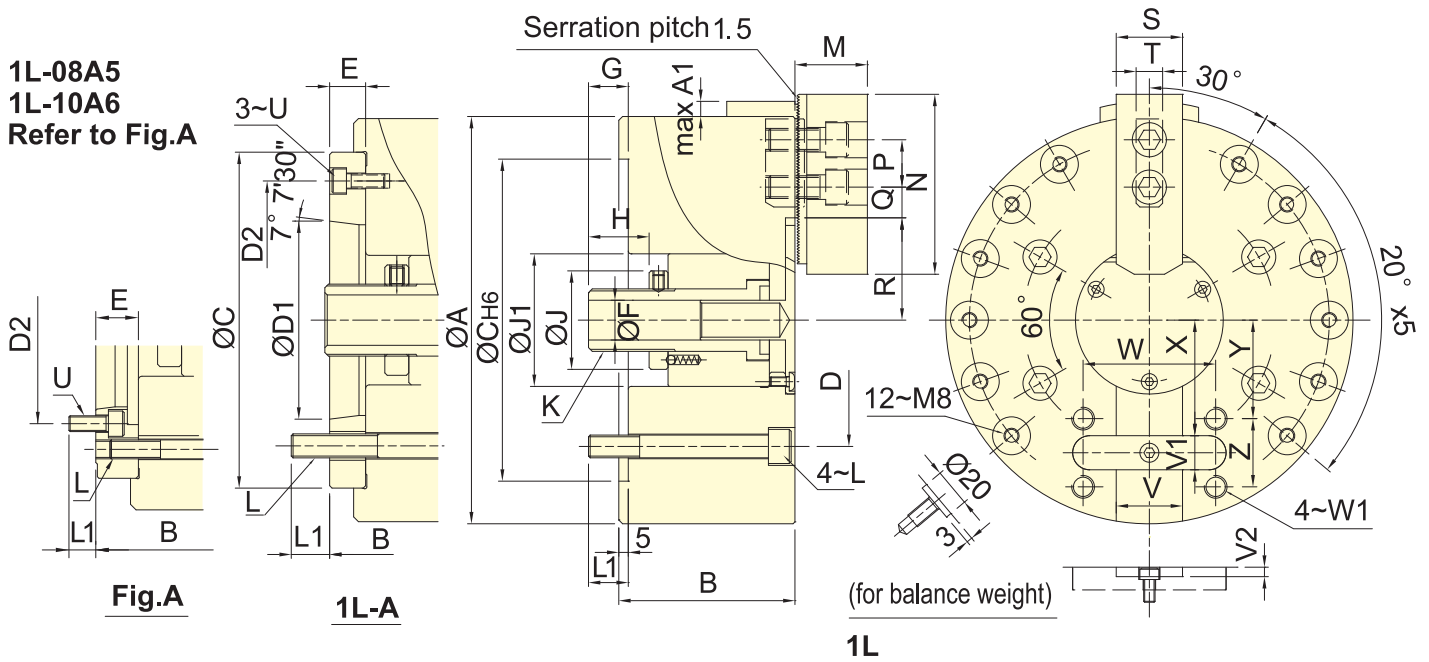

#### Specifications

Model	Plunger stroke (mm)	Jaw stroke (Dia.) (mm)	Chuck Dia. Max. (mm)	Chuck Dia. Min. (mm)	Max. D.B. pull kN (kgf)	Max. clamping force kN (kgf)	Max. speed min <sup>3</sup> (r.p.m.)	I kg · m <sup>2</sup>	Weight (kg)	Matching cyl.	Max. pressure MPa (kgf/cm <sup>2</sup> )	
1L-06 A5	20	16	168	17	12.3(1250)	27.3(2780)	3800	0.05	12.5	14.3	RK-100	1.7(17.5)
1L-08 A5	25	20	215	20	15.7(1600)	37.2(3800)	3000	0.15	24.2	27.1	RK-125	1.4(14.3)
1L-08 A6	25	20	215	20	15.7(1600)	37.2(3800)	3000	0.15	24.2	25.3	RK-125	1.4(14.3)
1L-10 A6	30	24	254	25	21.6(2200)	48.5(4950)	2400	0.28	38.8	46	RK-125	1.9(19.5)
1L-10 A8	30	24	254	25	21.6(2200)	48.5(4950)	2400	0.28	38.8	44.3	RK-125	1.9(19.5)

#### Dimensions

Model	A	A1	B	B	C	D	D1	D2	E	F	Gmax	Gmin	H	J	J1	K max.	L	L1	L1	M	N	P	Q max.	Q min.	R max.	R min.	S	T	U	V(H6)	V1(H9)	V2	W	W1	X	Y	Z
1L-06 A5	168	9.5	80	90	140	104.8	82.56	116	15	21	37	17	25	46	54	M30x1.5	M10	16	16	37	73	20	19.75	7.75	46	30	31	12	M6	30	15	4.5	64	M10	45	36	30
1L-08 A5	215	8	93	111	170	133.4	82.56	104.8	23	21	46	21	32	52	70	M33x1.5	M12	21	19	38	95	25	25.25	10.25	54	34	35	14	M6	35	18	4.5	70	M12	61	52	36
1L-08 A6	215	8	93	105	170	133.4	106.38	150	17	21	46	21	32	52	70	M33x1.5	M12	21	20	38	95	25	25.25	10.25	54	34	35	14	M6	35	18	4.5	70	M12	61	52	36
1L-10 A6	254	13.5	108	128	220	171.4	106.38	133.4	25	30	47	17	30	62	90	M45x1.5	M16	25	20	43	110	30	33.75	11.25	67	43	40	16	M8	40	20	5	90	M12	71	58.5	45
1L-10 A8	254	13.5	108	121	220	171.4	139.72	190	18	30	47	17	30	62	90	M45x1.5	M16	25	27	43	110	30	33.75	11.25	67	43	40	16	M8	40	20	5	90	M12	71	58.5	45

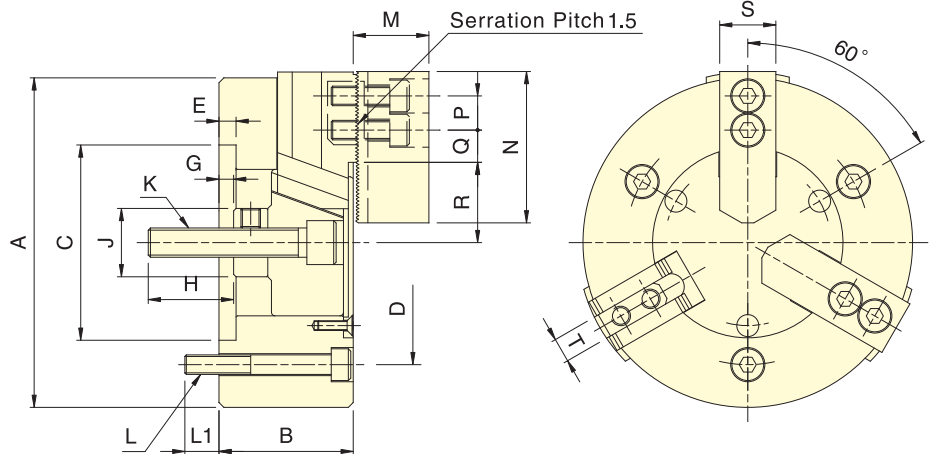

**3M-05**

- 3-Jaw WEDGE style Closed Center and extra-long jaw stroke
- All mating surfaces and internal parts are hardened, ground and lubricated
- High rigidity and clamping accuracy

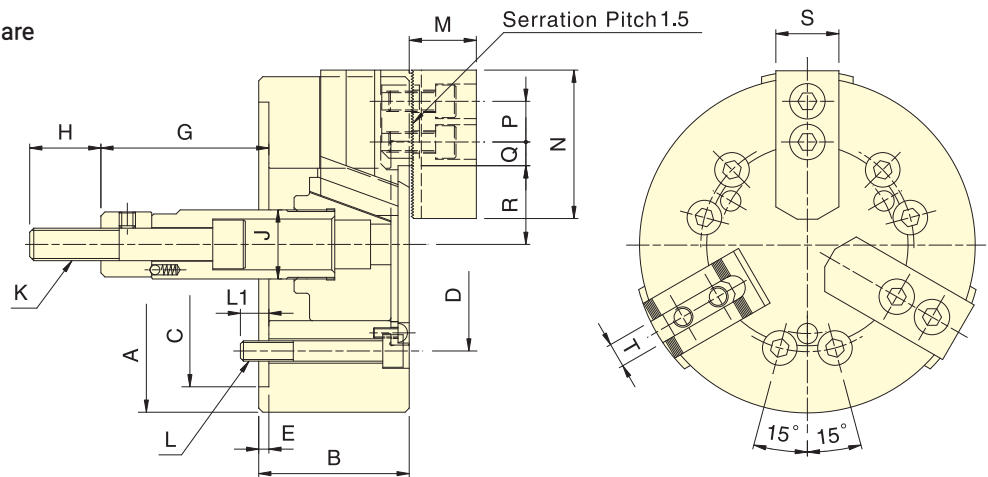

**3M-06~3M-12**

### Specifications

Model	Plunger stroke (mm)	Jaw stroke (Dia.) (mm)	Chucking Dia. Max. (mm)	Chucking Dia. Min. (mm)	Max. D.B. pull kN (kgf)	Max. clamping force kN (kgf)	Max. speed min <sup>-1</sup> (r.p.m.)	I kg · m <sup>2</sup>	Weight (kg)	Matching cyl.	Max. pressure MPa (kgf/cm <sup>2</sup> )
3M-05	15	10.9	135	14	9.8(1000)	16.4(1670)	4500	0.02	6	RK-75(N)	2.7(27)
3M-06	20	14.5	165	14	21.6(2200)	36(3680)	4000	0.04	12.2	RK-100(N)	3.0(30)
3M-08	23	16.7	210	17	29.4(3000)	54.9(5600)	3500	0.13	23	RK-125(N)	2.9(29)
3M-10	27	19.6	254	22	39.2(4000)	74(7550)	3000	0.3	34.3	RK-150(N)	2.8(28)
3M-12	30	21.8	304	26	54(5500)	99(10100)	2500	0.71	59.4	RK-150(N)	3.6(36)

### Dimensions

Model	A	B	C(H6)	D	E	G max.	G min.	H	J	K	L	L1	M	N	P	Q max.	Q min.	R max.	R min.	S	T
3M-05	135	55	80	100	7	6	-9	35	28	M12x1.75	3~M8	14	31	62	14	17	5.5	32.9	27.45	25	10
3M-06	165	74	140	104.8	5	101.5	81.5	36	34	M16x2	6~M10	14	37	73	20	17.6	7	38.7	31.4	31	12
3M-08	210	85	170	133.4	5	129	106	36	38	M20x2.5	6~M12	20	38	95	25	22.8	8.8	47.5	39.1	35	14
3M-10	254	89	220	171.4	5	160	133	36	45	M20x2.5	6~M16	18	43	110	30	33	12.8	53.9	44.1	40	16
3M-12	304	106	220	171.4	6	70	40	46	50	M24x3	6~M16	18	51	130	30	47.8	13.3	62.5	51.6	50	21





- 3-Jaw WEDGE style Closed Center and extra-long jaw stroke
- All mating surfaces and internal parts are hardened, ground and lubricated
- High rigidity and clamping accuracy

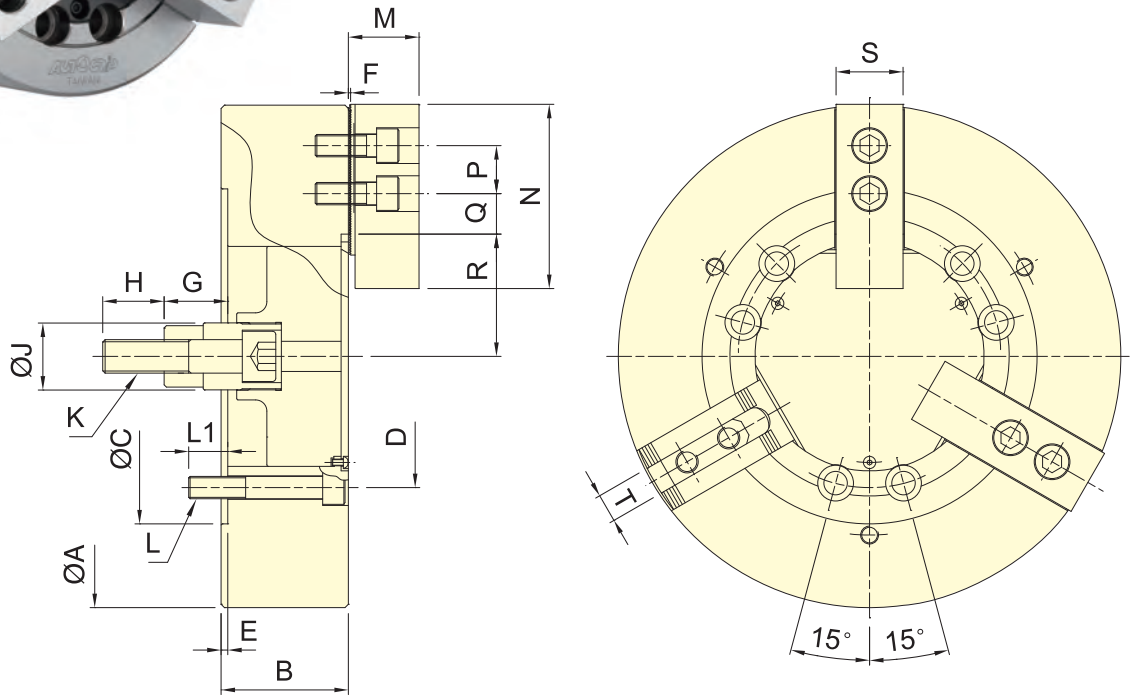

Specifications

Model	Plunger stroke (mm)	Jaw stroke (Dia.) (mm)	Chucking Dia. Max. (mm)	Chucking Dia. Min. (mm)	Max. D.B. pull kN (kgf)	Max. clamping force kN (kgf)	Max. speed min <sup>-1</sup> (r.p.m.)	I kg · m <sup>2</sup>	Weight (kg)	Matching cyl.	Max. pressure MPa (kgf/cm <sup>2</sup> )
* 3M-215	35	25.4	381	20	91.0(9280)	158.9(16200)	2300	1.8	96	RK-200(N)	3.0(30)
* 3M-218	35	25.4	450	51	91.0(9280)	158.9(16200)	2000	2.32	124	RK-200(N)	3.0(30)
* 3M-221	35	25.4	530	53	91.0(9280)	158.9(16200)	1350	4.9	175	RK-200(N)	3.0(30)
* 3M-224	35	25.4	610	160	91.0(9280)	158.9(16200)	1250	7.2	225	RK-200(N)	3.0(30)

Dimensions

Model	A	B	C(H6)	D	E	F	G max.	G min.	H	J	K	L	L1	M	N	P	Q max.	Q min.	R max.	R min.	S	T
* 3M-215	381	114	300	235	6	2	104	69	55	60	M30x3.5	6~M20	30	63.3	165	43	49.75	18.25	79	66.3	62	25.5
* 3M-218	450	114	300	235	6	2	92	57	55	60	M30x3.5	6~M20	35	63.3	165	43	51.25	18.25	109.5	96.8	62	25.5
* 3M-221	530	125	380	330.2	6	3	97	62	55	60	M30x3.5	6~M24	31	71	180	60	89	76.3	89	76.3	65	25
* 3M-224	610	125	380	330.2	6	3	97	62	55	60	M30x3.5	6~M24	31	71	180	60	128	115.3	128	115.3	65	25

\*model produced only by order.

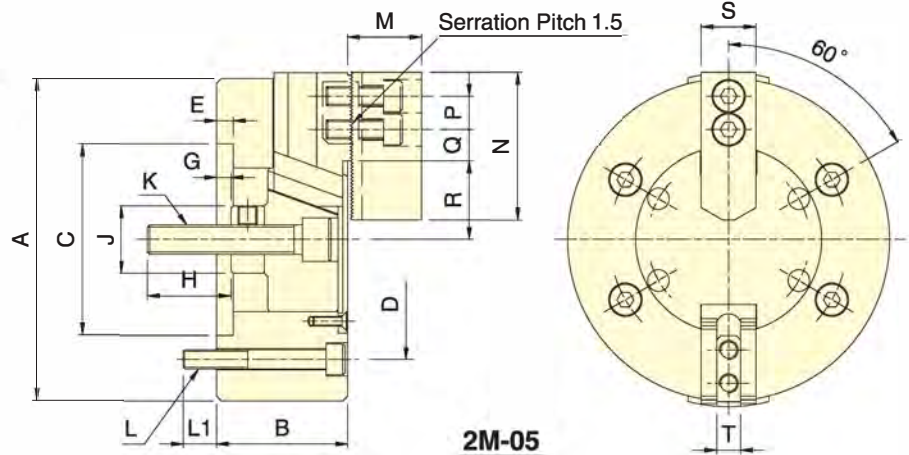

- 2-Jaw WEDGE style Closed Center and extra-long jaw stroke
- All mating surfaces and internal parts are hardened, ground and lubricated
- High rigidity and clamping accuracy

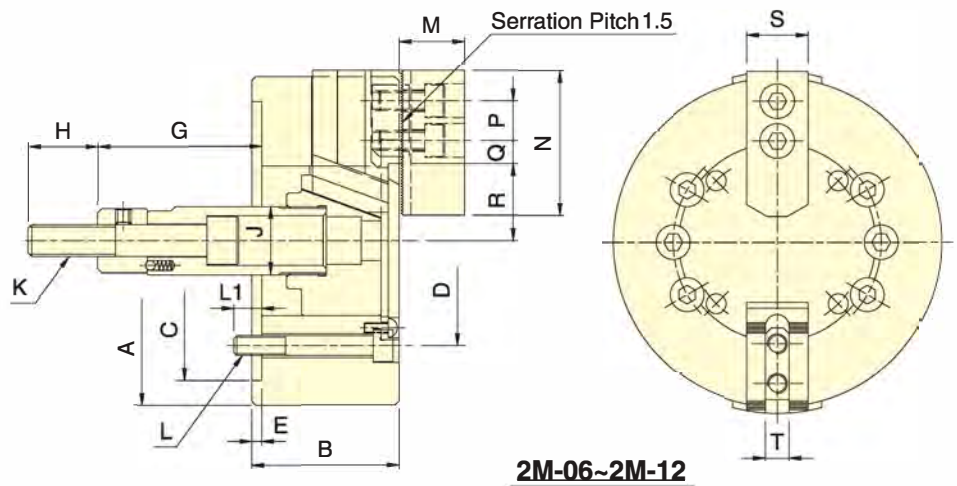

### Specifications

Model	Plunger stroke (mm)	Jaw stroke (Dia.) (mm)	Chucking Dia. Max. (mm)	Chucking Dia. Min. (mm)	Max. D.B. pull kN (kgf)	Max. clamping force kN (kgf)	Max. speed min <sup>-1</sup> (r.p.m.)	I kg · m <sup>2</sup>	Weight (kg)	Matching cyl.	Max. pressure MPa (kgf/cm <sup>2</sup> )
2M-05	15	10.9	135	14	6.5(660)	11(1120)	4500	0.02	6	RK-75(N)	1.8(18)
2M-06	20	14.5	165	14	14.3(1460)	24(2450)	4000	0.04	12.2	RK-100(N)	2.0(20)
2M-08	23	16.7	210	17	19.6(2000)	36.6(3730)	3500	0.13	23	RK-125(N)	1.9(19.3)
2M-10	27	19.6	254	22	26.1(2660)	49.3(5030)	3000	0.3	34.3	RK-150(N)	1.8(18.6)
2M-12	30	21.8	304	26	36(3670)	66(6730)	2500	0.71	59.1	RK-150(N)	2.4(24)

### Dimensions

Model	A	B	C(H6)	D	E	G max.	G min.	H	J	K	L	L1	M	N	P	Q max.	Q min.	R max.	R min.	S	T
2M-05	135	55	80	100	7	6	-9	35	28	M12x1.75	4~M8	14	31	62	14	17	5.5	32.9	27.45	25	10
2M-06	165	74	140	104.8	5	101.5	81.5	36	34	M16x2	6~M10	14	37	73	20	17.6	7	38.7	31.4	31	12
2M-08	210	85	170	133.4	5	129	106	36	38	M20x2.5	6~M12	20	38	95	25	22.8	8.8	47.5	39.1	35	14
2M-10	254	89	220	171.4	5	160	133	36	45	M20x2.5	6~M16	18	43	110	30	33	12.8	53.9	44.1	40	16
2M-12	304	106	220	171.4	6	70	40	46	50	M24x3	6~M16	18	51	130	30	47.8	13.3	62.5	51.6	50	21



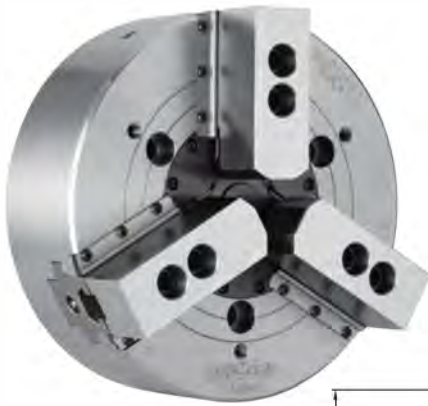

#### Application/customer benefits

- 3-Jaw WEDGE style high speed design, Closed Center
- Sealed against swarf, chips and coolant
- Suitable for vertical applications

3V-15A8  
3V-15A15  
3V-18A8  
3V-18A15  
3V-21A11  
3V-24A11  
Refer to Fig.A

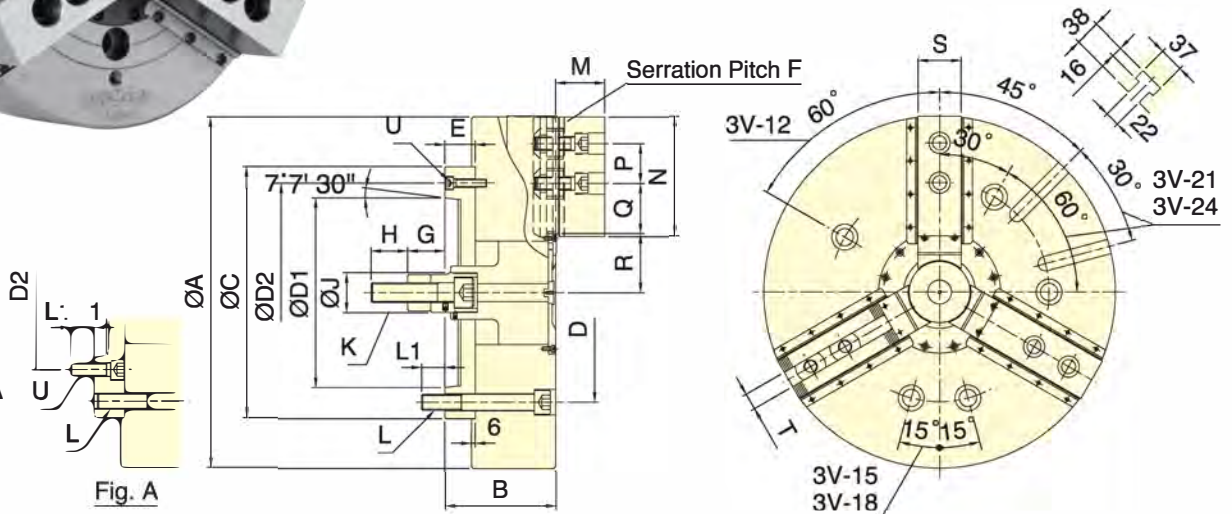

#### Specifications

Model	Plunger stroke (mm)	Jaw stroke (Dia.) (mm)	Chucking Dia. Max. (mm)	Chucking Dia. Min. (mm)	Max. D.B. pull kN (kgf)	Max. clamping force kN (kgf)	Max. speed min <sup>1</sup> (r.p.m.)	I kg · m <sup>2</sup>	Weight (kg)	Matching cyl.	Max. pressure MPa (kgf/cm <sup>2</sup> )
3V-12 A8	30	12.7	304	22	41(4180)	156(15900)	3150	0.8	66	RK-150 RE-150	2.9(29)
3V-15 A8	35	16	381	30	81.9(8360)	245.1(125000)	2900	2.3	130	RK-200 RE-200K	3.2(32) 3.4(34)
3V-15 A11	35	16	381	30	81.9(8360)	245.1(125000)	2900	2.3	129	RK-200 RE-200K	3.2(32) 3.4(34)
3V-15 A15	35	16	381	30	81.9(8360)	245.1(125000)	2900	2.7	137	RK-200 RE-200K	3.2(32) 3.4(34)
3V-18 A8	35	16	450	80	81.9(8360)	245.1(125000)	2600	3.3	159	RK-200 RE-200K	3.2(32) 3.4(34)
3V-18 A11	35	16	450	80	81.9(8360)	245.1(125000)	2600	3.3	158	RK-200 RE-200K	3.2(32) 3.4(34)
3V-18 A15	35	16	450	80	81.9(8360)	245.1(125000)	2600	3.7	165	RK-200 RE-200K	3.2(32) 3.4(34)
3V-21 A11	35	16	530	62	81.9(8360)	271.6(27700)	1800	5.3	229	RK-200 RE-200K	3.2(32) 3.4(34)
3V-21 A15	35	16	530	62	81.9(8360)	271.6(27700)	1800	5.2	222	RK-200 RE-200K	3.2(32) 3.4(34)
3V-24 A11	35	16	610	136	81.9(8360)	271.6(27700)	1700	7.6	270	RK-200 RE-200K	3.2(32) 3.4(34)
3V-24 A15	35	16	610	136	81.9(8360)	271.6(27700)	1700	7.3	263	RK-200 RE-200K	3.2(32) 3.4(34)
3V-32 A15	35	16	800	136	81.9(8360)	271.6(27700)	1100	36.2	430	RK-200 RE-200K	3.2(32) 3.4(34)

#### Dimensions

Model	A	B	C	D	D1	D2	E	F	G max.	G min.	H	J	K	L	L1	M	N	P	Q max.	Q min.	R max.	R min.	S	T	U
3V-12 A8	304	141	220	171.4	139.72	190	40	1.5	73	43	36	50	M20x2.5	3~M16	24	54	130	30	47.5	15.75	61	54.7	50	21	3~M8
3V-15 A8	381	164	300	235	139.72	171.4	54	1.5	99	64	55	60	M30x3.5	6~M20	24	66	165	43	51.25	18.25	77.5	69.5	62	25.5	6~M16
3V-15 A11	381	168	300	235	196.87	260	58	1.5	95	60	55	60	M30x3.5	6~M20	32	66	165	43	51.25	18.25	77.5	69.5	62	25.5	3~M10
3V-15 A15	381	172	380	235	285.78	330.2	62	1.5	91	56	55	60	M30x3.5	6~M20	26	66	165	43	51.25	18.25	77.5	69.5	62	25.5	6~M24
3V-18 A8	450	164	300	235	139.72	171.4	54	1.5	99	64	55	60	M30x3.5	6~M20	24	66	165	43	51.25	18.25	108	100	62	25.5	6~M16
3V-18 A11	450	168	300	235	196.87	260	58	1.5	95	60	55	60	M30x3.5	6~M20	32	66	165	43	51.25	18.25	108	100	62	25.5	3~M10
3V-18 A15	450	172	380	235	285.78	330.2	62	1.5	91	56	55	60	M30x3.5	6~M20	26	66	165	43	51.25	18.25	108	100	62	25.5	6~M24
3V-21 A11	530	167	380	330.2	196.87	235	46	3	91	56	55	60	M30x3.5	6~M24	35	76	180	60	93.5	24.5	89	81	65	25	6~M20
3V-21 A15	530	167	380	330.2	285.78	330.2	46	3	91	56	55	60	M30x3.5	6~M24	35	76	180	60	93.5	24.5	89	81	65	25	3~M12
3V-24 A11	610	167	380	330.2	196.87	235	46	3	91	56	55	60	M30x3.5	6~M24	35	76	180	60	93.5	24.5	128	120	65	25	6~M20
3V-24 A15	610	167	380	330.2	285.78	330.2	46	3	91	56	55	60	M30x3.5	6~M24	35	76	180	60	93.5	24.5	128	120	65	25	3~M12
3V-32 A15	800	167	380	330.2	285.78	330.2	46	3	91	56	55	60	M30x3.5	6~M24	35	76	180	60	189.5	24.5	128	120	65	25	3~M12

#### Application/customer benefits

- 3-Jaw WEDGE style high speed design, Closed Center
- Manual radial setting of the master jaws for centering the workpiece
- Sealed against swarf, chips and coolant
- Suitable for vertical applications

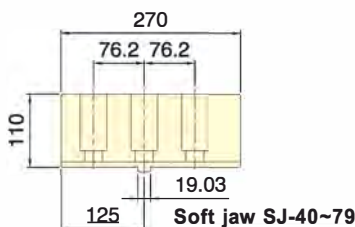
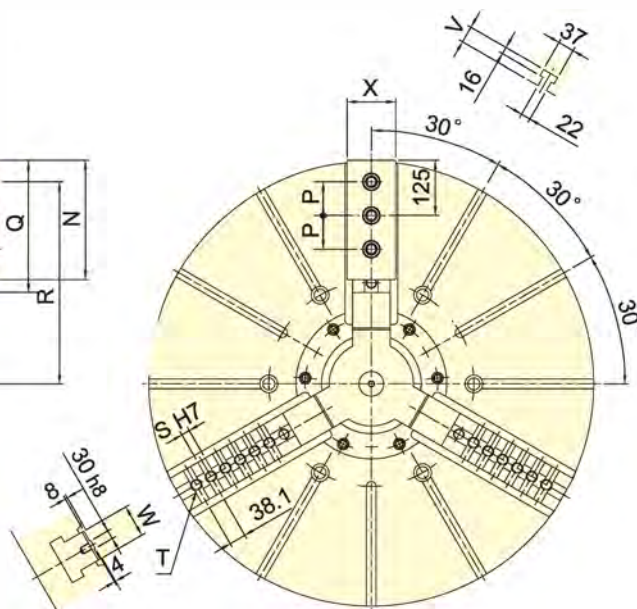
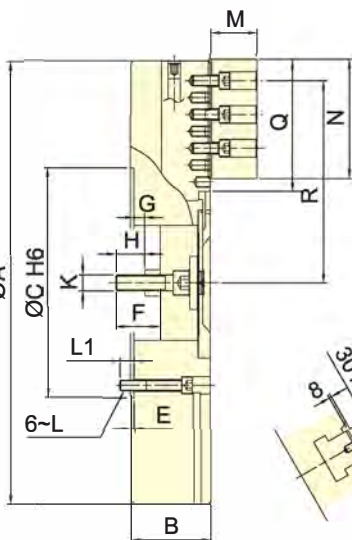
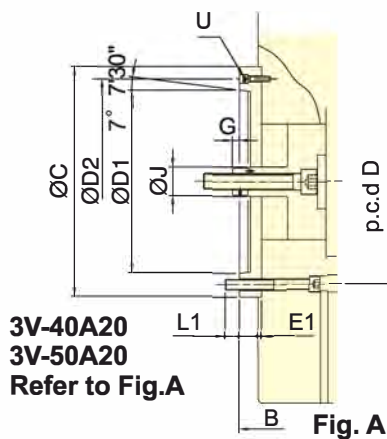

#### Specifications

Model	Plunger stroke (mm)	Jaw stroke (Dia.) (mm)	Chucking Dia. Max. (mm)	Chucking Dia. Min. (mm)	Max. D.B. pull kN (kgf)	Max. clamping force kN (kgf)	Max. speed min <sup>-1</sup> (r.p.m.)	l kg · m <sup>2</sup>	Weight (kg)	Matching cyl.	Max. pressure MPa (kgf/cm <sup>2</sup> )
3V-40 <b>A20</b>	57	46+(60)	1005	380	180(18350)	320(32620)	630	68 <b>72</b>	780 <b>849</b>	RK-250,RE-250 RE-A250,RE-L250	4.24(43.2)
3V-50 <b>A20</b>	57	46+(60)	1250	600	180(18350)	320(32620)	500	145 <b>148</b>	800 <b>869</b>	RK-250,RE-250 RE-A250,RE-L250	4.24(43.2)
3V-63	60	48+(80)	1600	600	200(20390)	360(36700)	400	500	1600	RK-250,RE-250 RE-A250,RE-L250	4.76(46.7)
3V-79	60	48+(80)	2000	1000	200(20390)	360(36700)	320	1250	2500	RK-250,RE-250 RE-A250,RE-L250	4.76(46.7)

#### Dimensions

Model	A	B	C	D	D1	D2	E	E1	F	G max.	G min.	H	J	K	L	L1	M	N	P	Q	R max.	R min.	S	T	U	V	W	X			
3V-40 <b>A20</b>	1005	184	<b>222</b>	520	463.6	<b>412.78</b>	463.6	8	<b>50</b>	100	24	<b>73</b>	-33	<b>16</b>	65	65	M36	M24	37	110	270	76.2	295	457	404	6~19.03	7~M24	<b>3~M12</b>	38	85	84
3V-50 <b>A20</b>	1250	184	<b>222</b>	520	463.6	<b>412.78</b>	463.6	8	<b>50</b>	100	24	<b>73</b>	-33	<b>16</b>	65	65	M36	M24	37	110	270	76.2	416	563	510	9~19.03	9~M24	<b>3~M12</b>	38	85	84
3V-63	1600	222	720	647.6	-	-	8	-	218	131	71	65	-	M36	M30	46	110	270	76.2	540	738	674	12~19.03	13~M24	-	42	110	110			
3V-79	2000	240	720	647.6	-	-	8	-	238	133	73	65	-	M36	M30	48	110	270	76.2	740	914	850	16~19.03	17~M24	-	42	110	110			





### Application/customer benefits

- 3-Jaw Pull Lock style with closed center
- Simultaneous radial clamping and axial pull down of workpiece allowing for machining closer to the surface of the chuck and obtaining parallelism of workpiece
- Works with airtight detection and axial positioning systems
- Excellent option for long length parts
- Heat treatment/hardening of the chuck body, precision boring and precision machining of all chuck parts guarantee accuracy, high clamping force and long life and make this chuck suitable for heavy duty machining applications.

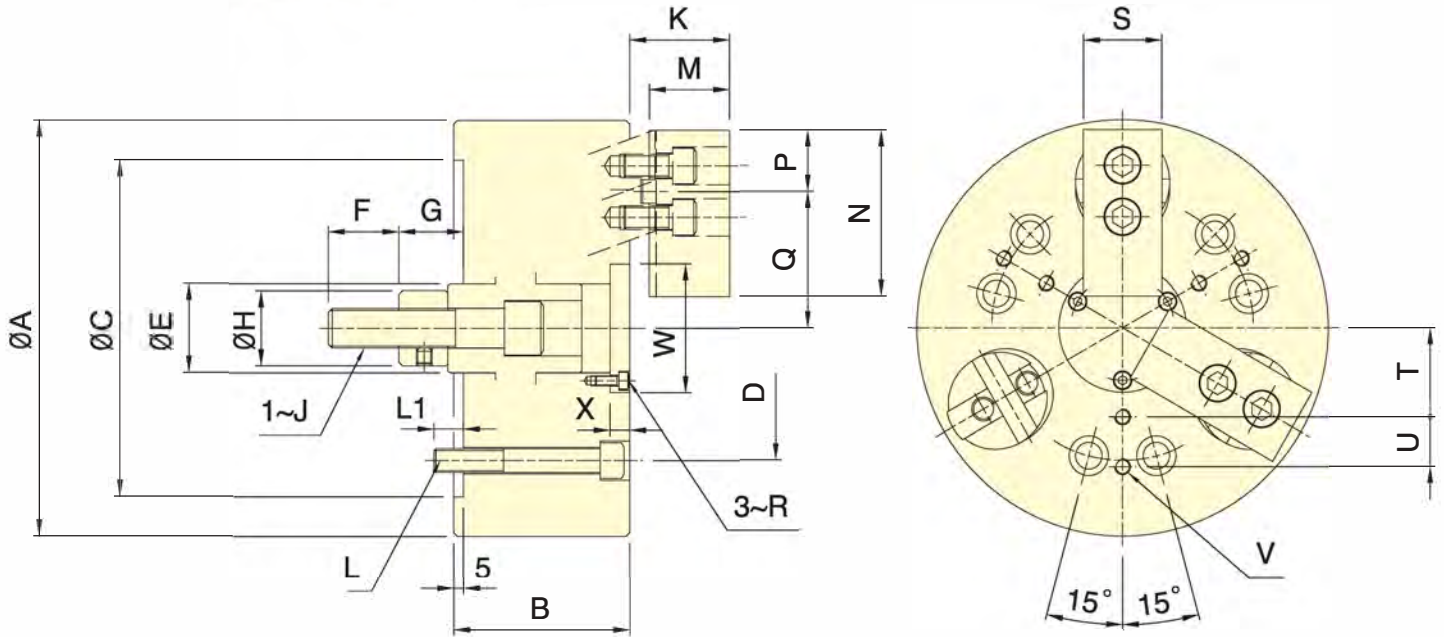

### Specifications

Model	Plunger stroke (mm)	Jaw stroke (Dia.) (mm)	Chucking Dia. Max. (mm)	Chucking Dia. Min. (mm)	Max. D.B. pull kN (kgf)	Max. clamping force kN (kgf)	Max. speed min <sup>1</sup> (r.p.m.)	l kg · m <sup>2</sup>	Weight (kg)	Matching cyl.	Max. pressure MPa (kgf/cm <sup>2</sup> )
3D-04	7	5	110	13	6.0(612)	10.5(1070)	3500	0.007	4.5	RK-75	1.6(16.5)
3D-05	7	5	135	21	10.0(1020)	17.0(1730)	3500	0.018	7.9	RK-75	2.7(27.5)
3D-06	10	7.2	165	22	15.0(1530)	25.0(2550)	3500	0.051	15	RK-100	2.1(21.4)
3D-08	10	7.2	210	28	25.0(2550)	45.0(4590)	3000	0.15	26	RK-125	2.2(22.5)
3D-10	15	10.8	254	35	35.0(3569)	60.0(6118)	2500	0.37	46	RK-125	3.1(31.6)
3D-12	15	10.8	304	50	45.0(4590)	75.0(7650)	2000	0.79	70	RK-150	2.8(28.5)
*3D-15	20	14.5	381	60	53.9(5500)	90.0(9180)	1500	2.25	132	RK-150	3.4(34.2)

### Dimensions

Model	A	B	C	D	E	F	G max.	G min.	H	J	K max.	K Min.	L	L1	M	N	P	Q max.	Q min.	R	S	T	U	V	W	X
3D-04	110	60	85	70.6	25	20	22	15	25	M10	30	23	3~M10	15	19.5	50	22	37	34.5	M3	25	22.5	-	3~M6	35	2
3D-05	135	70	110	82.6	30	25	24	17	28	M12	35	28	3~M10	16	24.5	56	23	46	43.5	M3	30	27.5	-	3~M6	44	2
3D-06	165	85	140	104.8	35	36	37	27	32	M16	45	35	6~M10	16	31	70	27	57.7	54.3	M4	35	35	20	6~M6	52	7
3D-08	210	90	170	133.4	45	36	38	28	38	M20	56	46	6~M12	15	41	84	31	70.8	67.2	M5	40	45	25	6~M8	65	10
3D-10	254	110	220	171.5	55	46	47	32	50	M24	65	50	6~M16	24	46	100	38	85	79.6	M6	50	55	30	6~M8	75	12
3D-12	304	125	220	171.5	55	50	49.5	34.5	53	M27	65	50	6~M16	22	51	120	42	101.9	96.5	M6	60	70	35	6~M10	90	12
*3D-15	381	140	300	235	70	55	61	41	55	M30	86	66	6~M20	30	60	165	60	135.6	128.3	M8	70	95	45	6~M12	120	13

\*model produced only by order.

SPECIAL PURPOSE



### Application/customer benefits

- 2-Jaw Pull Lock style with closed center
- Simultaneous radial clamping and axial pull down of workpiece allowing for machining closer to the surface of the chuck
- Works with airtight detection and axial positioning systems
- Excellent option for long length parts
- Heat treatment/hardening of the chuck body, precision boring and precision machining of all chuck parts guarantee accuracy, high clamping force and long life and make this chuck suitable for heavy duty machining applications

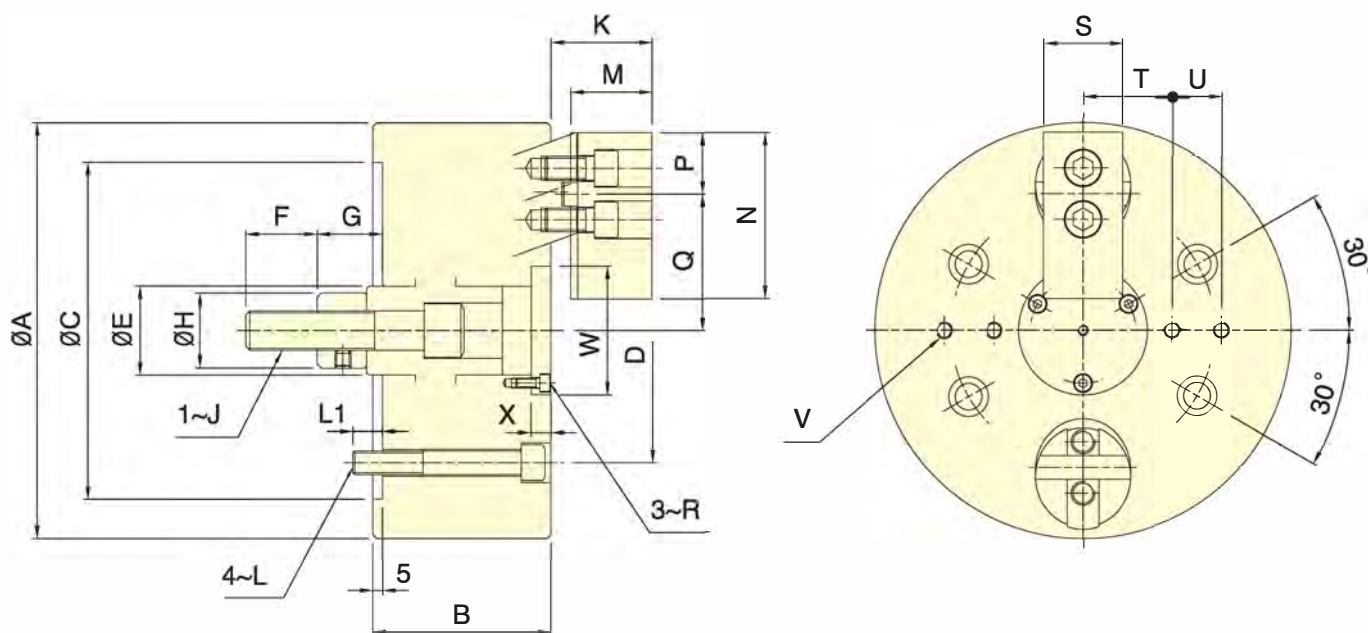

SPECIAL PURPOSE

### Specifications

Model	Plunger stroke (mm)	Jaw stroke (Dia.) (mm)	Chucking Dia. Max. (mm)	Chucking Dia. Min. (mm)	Max. D.B. pull kN (kgf)	Max. clamping force kN (kgf)	Max. speed min <sup>-1</sup> (r.p.m.)	I kg · m <sup>2</sup>	Weight (kg)	Matching cyl.	Max. pressure MPa (kgf/cm <sup>2</sup> )
2D-06	10	7.2	165	22	10.0(1020)	16.7(1700)	3500	0.045	12	RK-100	1.4(14.3)
2D-08	10	7.2	210	28	16.7(1700)	30.0(3060)	3500	0.13	23	RK-125	1.5(15)
2D-10	15	10.8	254	35	23.3(2379)	40.0(4079)	2500	0.34	43	RK-125	2.1(21.1)

### Dimensions

Model	A	B	C	D	E	F	G max.	G min.	H	J	K max.	K Min.	L	L1	M	N	P	Q max.	Q min.	R	S	T	U	V	W	X
2D-06	165	85	140	104.8	35	36	37	27	32	M16	45	35	M10	16	31	70	27	57.7	54.3	M4	35	35	20	4~M6	52	7
2D-08	210	90	170	133.4	45	36	38	28	38	M20	56	46	M12	15	41	84	31	70.8	67.2	M5	40	45	25	4~M8	65	10
2D-10	254	110	220	171.4	55	46	47	32	50	M24	65	50	M16	24	46	100	38	85	79.6	M6	50	55	30	4~M8	75	12





Application/customer benefits

- 3-Jaw Pin Arbor / Draw Down style with thru-hole
- High radial gripping force and high accuracy
- Suitable for both finishing and heavy machining

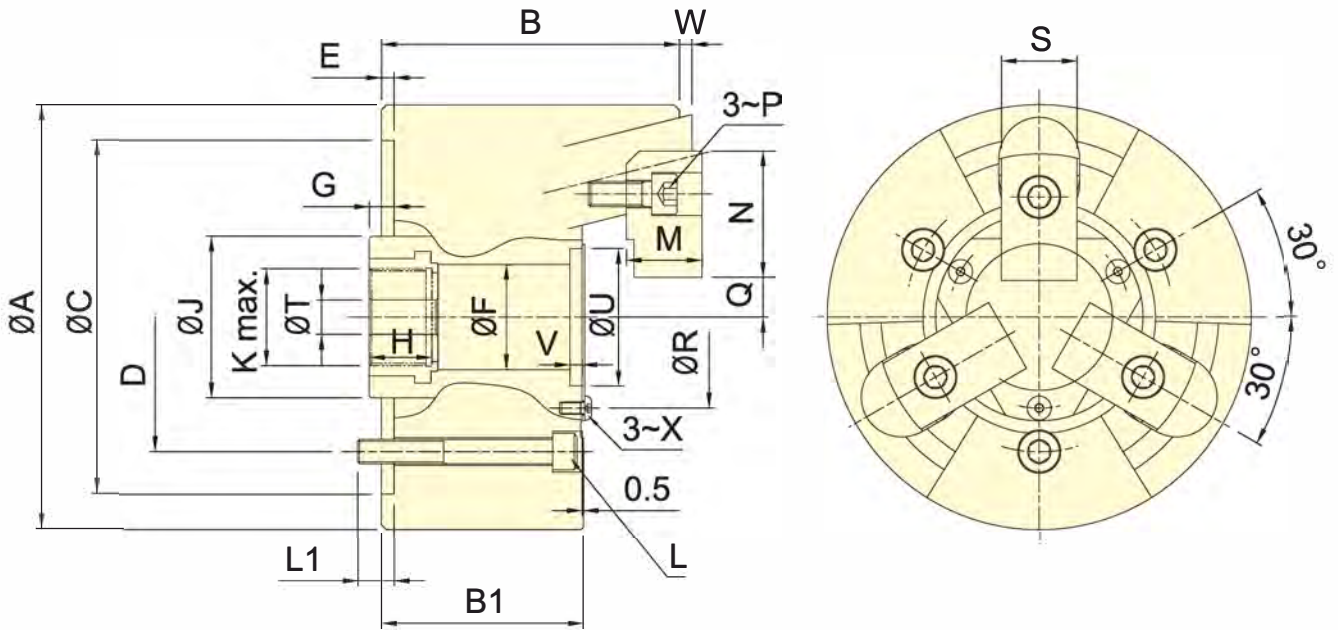

SPECIAL PURPOSE

Specifications

Model	Plunger stroke (mm)	Jaw stroke (Dia.) (mm)	Chucking Dia. Max. (mm)	Chucking Dia. Min. (mm)	Max. D.B. pull kN (kgf)	Max. clamping force kN (kgf)	Max. speed min <sup>-1</sup> (r.p.m.)	l kg · m <sup>2</sup>	Weight (kg)	Matching cyl.	Max. pressure MPa (kgf/cm <sup>2</sup> )
3U-203	4	2	42	14	5.8(590)	16.7(1700)	10000	0.001	1.8	RK-75(N)	1.6(16)
3U-204	6	3	60	10	10.0(1020)	28.4(2900)	8000	0.005	3.9	RK-75(N)	2.7(27)
3U-205	6	3	84	15	13.9(1420)	39.7(4050)	8000	0.012	6.8	RK-100(N)	2.0(20)
3U-206	10	5	105	24	17.9(1830)	57.8(5900)	7000	0.055	14.7	RK-100(N)	2.6(26)
3U-208	10	5	132	25	25.0(2550)	80.0(8150)	6000	0.14	25.5	RK-125(N)	2.2(22)
3U-210	10	5	163	34	35.0(3570)	100.0(10100)	4500	0.36	43.5	RK-125(N)	3.1(31)
3U-212	10	5	210	81	35.0(3570)	100.0(10100)	3600	0.68	63	RK-125(N)	3.1(31)

Dimensions

Model	A	B	B1	C(H6)	D	E	F	G max.	G min.	H	J	K	L	L1	M	N	P	Q max.	Q min.	R	S	T	U(H6)	V	W Max.	W Min.	X
3U-203	85	54.5	42	70	54	3.5	25	18	14	22	38	M20x1.5	3~M8	11	12	26	M5	7.5	6.5	38	15	10	32	3.5	2	-2	M3
3U-204	110	72.5	55	85	70.6	4	30	16	10	24.5	42	M24x1.5	3~M10	12	17	32	M6	10.75	9.25	46	20	10	38	4	3	-3	M4
3U-205	135	84.5	63	110	82.6	4	35	16	10	26	50	M28x1.5	3~M10	15	20	41.5	M8	13.25	11.75	55	24	10	45	5	3	-3	M5
3U-206	168	118	80	140	104.8	5	45	20	10	31	60	M35x1.5	3~M10	16.5	30	50	M10	15.75	13.25	72	30	17	58	6	5	-5	M5
3U-208	210	137	92	170	133.4	5	52	21	11	31	80	M48x2	3~M12	18	34	63	M12	16.25	13.75	82	35	17	68	6	5	-5	M6
3U-210	254	152	102	220	171.4	5	75	25	15	37	105	M68x2	3~M16	23	39	74	M14	20.75	18.25	107	40	17	93	6	5	-5	M8
3U-212	304	157	102	220	171.4	5	100	25	15	37	135	M92x2	3~M16	26	44	74	M14	44.25	41.75	130	40	17	114	6	5	-5	M10



Application/customer benefits

- 3-Jaw Pin Arbor / Draw Down style with closed center
- High radial gripping force and high accuracy
- Suitable for both finishing and heavy machining

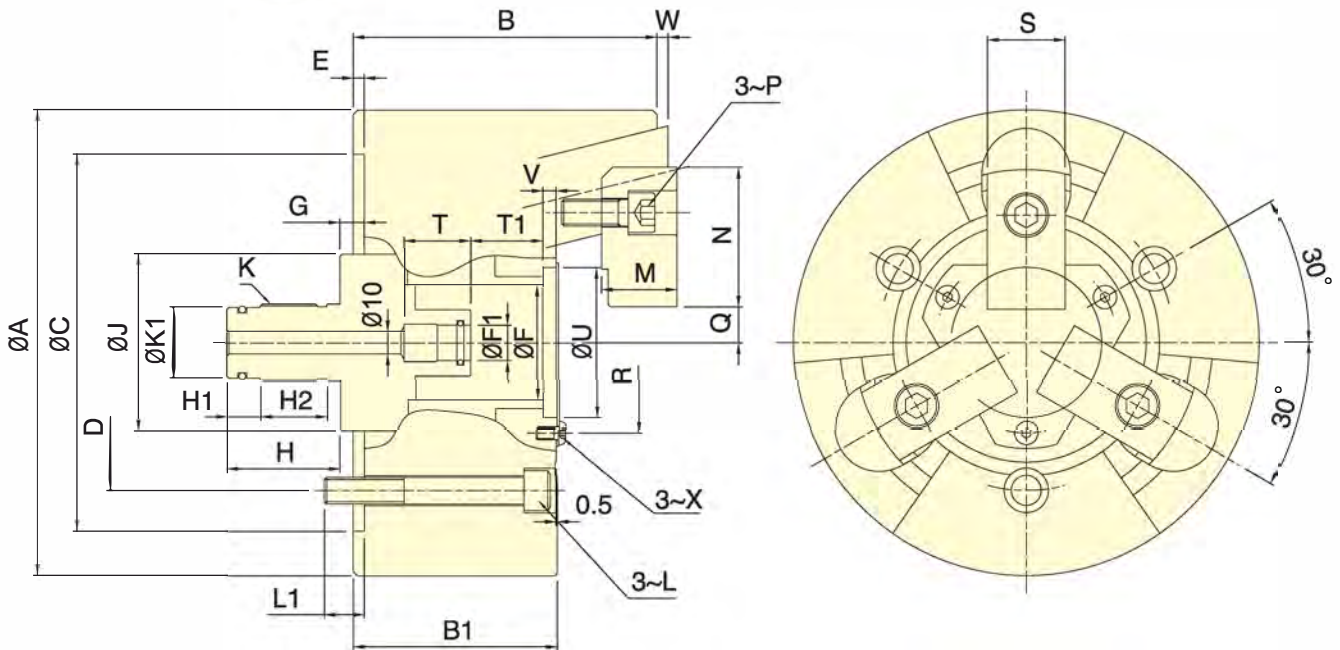

SPECIAL PURPOSE

Specifications

Model	Plunger stroke (mm)	Jaw stroke (Dia.) (mm)	Chucking Dia. Max. (mm)	Chucking Dia. Min. (mm)	Max. D.B. pull kN (kgf)	Max. clamping force kN (kgf)	Max. speed min <sup>-1</sup> (r.p.m.)	l kg · m <sup>2</sup>	Weight (kg)	Matching cyl.	Max. pressure MPa (kgf/cm <sup>2</sup> )
3U-205K	6	3	84	15	13.9(1420)	39.7(4050)	8000	0.018	6.8	RL-100 RL-A100N	2.0(20)
3U-206K	10	5	105	24	18.0(1835)	58.0(5910)	7000	0.055	14.9	RL-100 RL-A100N	2.5(25)
3U-208K	10	5	132	25	25.0(2550)	80.0(8150)	6000	0.14	25.8	RL-125 RL-A125N	2.2(22)
3U-210K	10	5	163	34	35.0(3570)	100(10100)	4500	0.36	44	RL-125 RL-A125N	3.1(31)
3U-212K	10	5	210	81	35.0(3570)	100(10100)	3600	0.68	63.8	RL-125 RL-A125N	3.1(31)

Dimensions

Model	A	B	B1	C(H6)	D	E	F	F1(H8)	G max.	G min.	H	H1	H2	J	K	K1	L	L1	M	N	P	Q max.	Q min.	R	S	T	T1	U(H6)	V	W Max.	W Min.	X
3U-205K	135	84.5	63	110	82.6	4	35	14	16	10	42	12	-	50	M25X1.5	22	M10	15	20	41.5	M8	13.25	11.75	55	24	25	15.5	45	5	3	-3	M5
3U-206K	168	118	80	140	104.8	4	45	14	20	10	48	12	30	60	M28X1.5	24	M10	16.5	30	50	M10	15.75	13.25	72	30	30	26.5	58	6	5	-5	M5
3U-208K	210	137	92	170	133.4	5	52	16	21	11	51	15	30	80	M35X1.5	30	M12	18	34	63	M12	16.25	13.75	82	35	30	32.5	68	6	5	-5	M6
3U-210K	254	152	102	220	171.4	5	75	16	25	15	51	15	30	105	M38X1.5	34	M16	23	39	74	M14	20.75	18.25	107	40	30	36.5	93	6	5	-5	M8
3U-212K	304	157	102	220	171.4	5	100	16	25	15	51	15	30	135	M45X1.5	40	M16	26	44	74	M14	44.25	41.75	130	40	30	36.5	114	6	5	-5	M10



Application/customer benefits

- 3-Jaw Pull Lock style for ID gripping with closed center
- Pull back function / Pressure Detection for parallelism
- High precision and stability for many ID gripping applications, including finishing

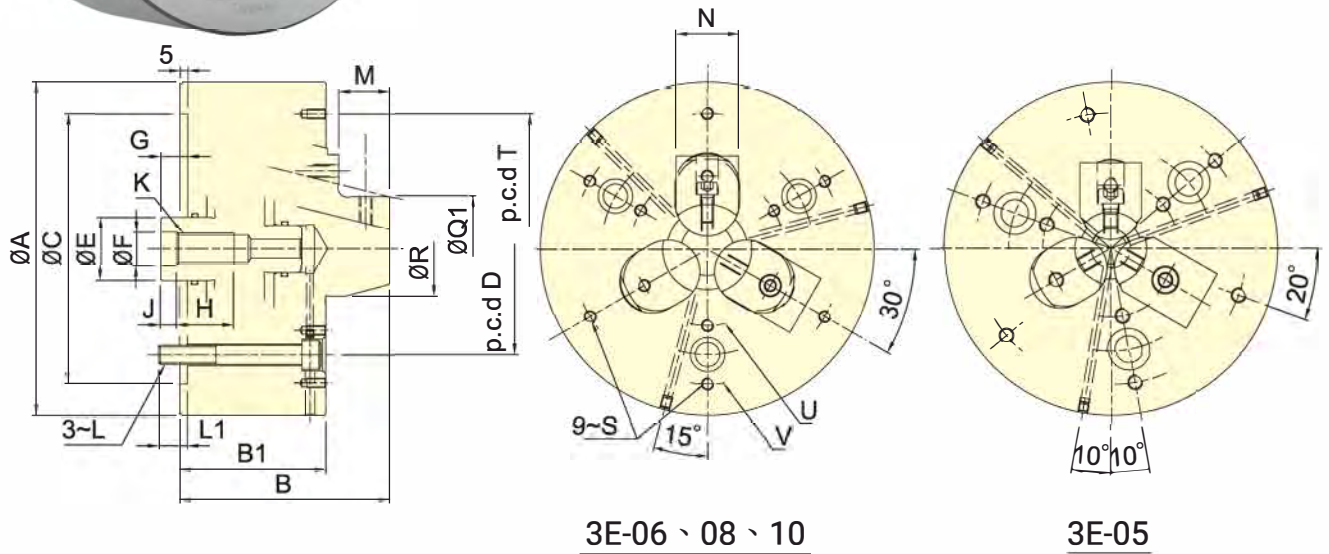

3E-06、08、10

3E-05

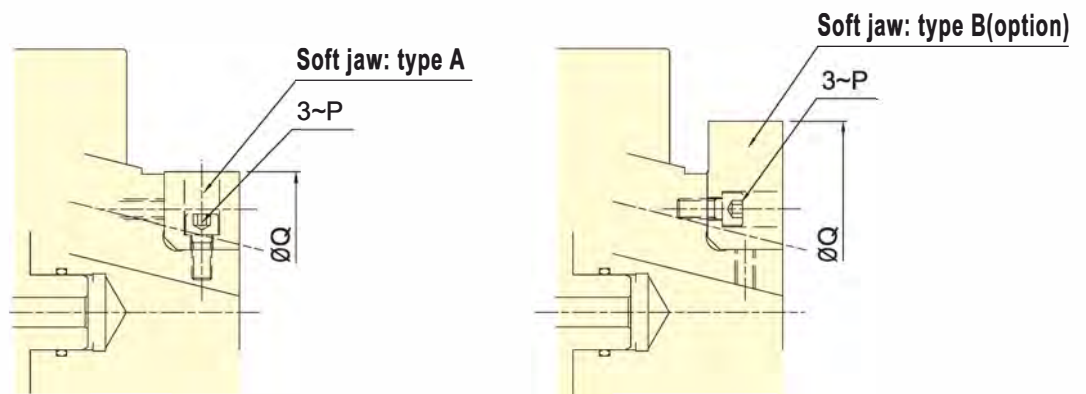

Specifications

Model	Plunger stroke (mm)	Jaw stroke (Dia.) (mm)	Chucking Dia. Max. (mm)	Chucking Dia. Min. (mm)	Max. D.B. pull kN (kgf)	Max. clamping force kN (kgf)	Max. speed min <sup>1</sup> (r.p.m.)	I kg · m <sup>2</sup>	Weight (kg)	Matching cyl.	Max. pressure MPa (kgf/cm <sup>2</sup> )
3E-05	6	3	83	29	13.0(1325)	42.0(4280)	7000	0.018	7.2	RK-100	1.8(18.5)
3E-06	10	5	110	44	18.0(1835)	58.0(5910)	6000	0.042	13.6	RK-100	2.5(25.6)
3E-08	10	5	150	50	25.0(2530)	80.0(8150)	5000	0.14	26.5	RK-125	2.2(22.5)
3E-10	10	5	190	60	35.0(3570)	100.0(10200)	3600	0.31	39.5	RK-150	2.8(28.5)

Dimensions

型號	A	B	B1	C(H6)	D	E	F(H8)	G max.	G min.	H	J	K	L	L1	M	N	P	Type A		Ttype B		Q1		R	S	T	U	V
																		Q max.	Q min.	Q max.	Q min.	Q max.	Q min.					
3E-05	135	98	72	110	82.6	25	18	18	12	25	8	M16	M10	15	20	25	M6	68	50	83	67	50	29	25	M6X12	110	55	110
3E-06	165	112	80	140	104.8	35	18	22	12	30	8	M16	M10	16	23	31	M6	90	70	110	89	70	44	40	M6X12	130	76	134
3E-08	210	132	90	170	133.4	40	21	22	12	36	10	M20	M12	18	30	35	M8	110	90	150	108	90	50	49	M6X12	170	100	170
3E-10	254	152	102	220	171.4	50	25	25	15	48	10	M24	M16	23	35	40	M10	127	110	190	125	110	60	59	M8X16	210	120	210

SPECIAL PURPOSE





### Application/customer benefits

- 3-Jaw Power Chuck with Inclined Master Jaws and closed center
- Inclined jaws pull workpiece towards the face to ensure parallelism
- Hh
- OD gripping only

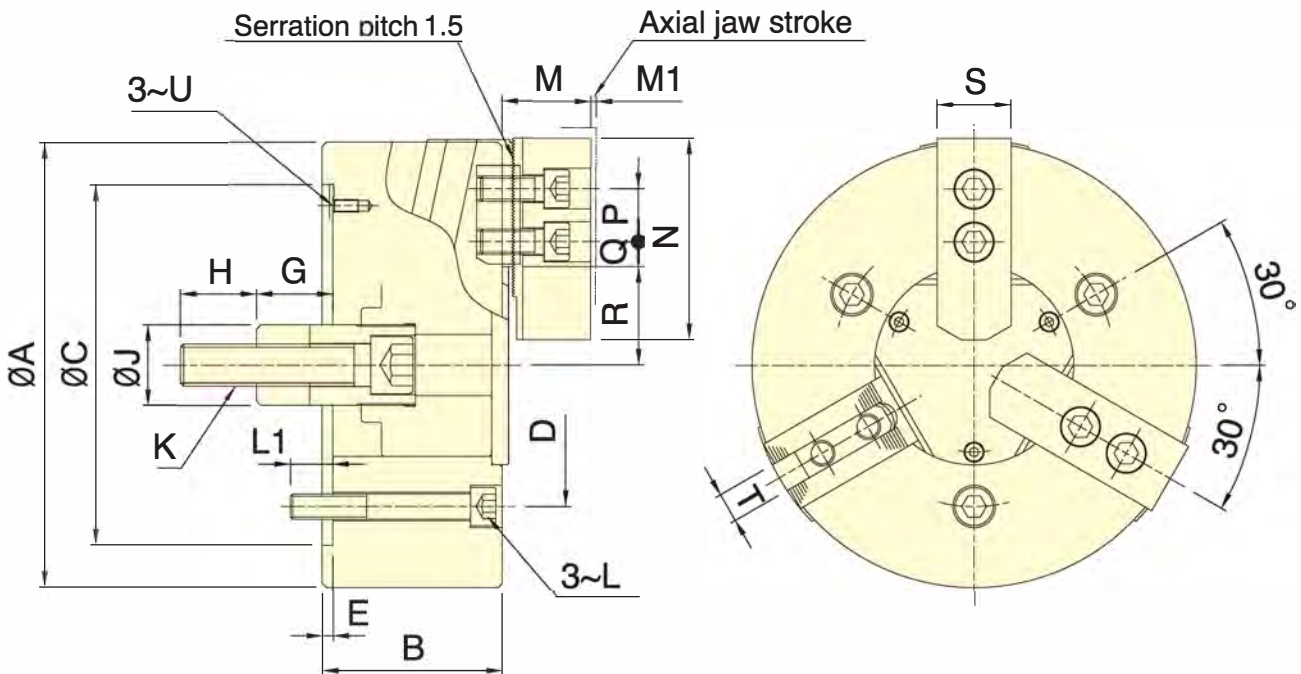

SPECIAL PURPOSE

### Specifications

Model	Plunger stroke (mm)	Jaw stroke (Dia.) (mm)	Chucking Dia. Max. (mm)	Chucking Dia. Min. (mm)	Max. D.B. pull kN (kgf)	Max. clamping force kN (kgf)	Max. speed min <sup>-1</sup> (r.p.m.)	I kg · m <sup>2</sup>	Weight (kg)	Matching cyl.	Max. pressure MPa (kgf/cm <sup>2</sup> )
3N-06	20	8.1(Axial0.9)	165	14	18(1835)	61.5(6270)	5000	0.05	11.1	RK-100(N)	2.6(26)
3N-08	23	9.4(Axial1.0)	210	17	25(2540)	85.8(8750)	4500	0.14	24.5	RK-125(N)	2.2(22)
3N-10	25	10.2(Axial1.1)	254	22	29(2950)	108(11000)	4000	0.32	34.5	RK-150(N)	1.8(18)

### Dimensions

Model	A	B	C(H6)	D	E	G max.	G min.	H	J	K	L	L1	M	M1	N	P	Q max.	Q min.	R max.	R min.	S	T	U
3N-06	165	72	140	104.8	5	54.5	34.5	36	34	M16X2	M10	16	41	0.9	73	20	15.25	7.75	38.3	34.05	31	12	M6
3N-08	210	85	170	133.4	5	59	36	36	38	M20X2.5	M12	20	42	1	95	25	22.25	11.75	46.3	41.45	35	14	M6
3N-10	254	89	220	171.4	5	63	38	36	45	M20X2.5	M16	24	47	1.1	110	30	33.75	11.25	52.1	46.8	40	16	M8



#### Application/customer benefits

- 3-Jaw Finger Style with closed center
- Eliminates thin walled workpiece deformation.
- Compensating mechanism allows clamping of material with irregular shapes
- Center stop is available to help center the workpiece

SPECIAL PURPOSE

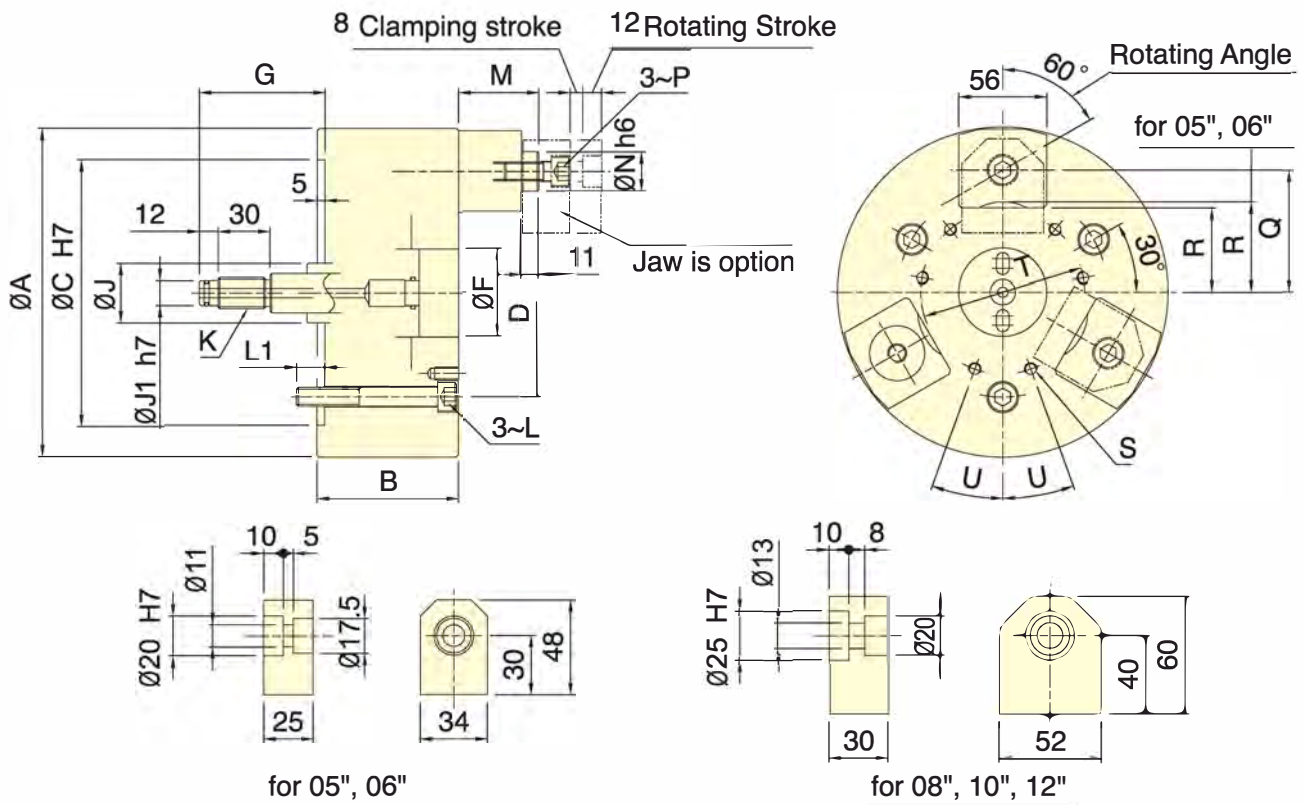

#### Specifications

Model	Plunger stroke (mm)	Jaw stroke (Dia.) (mm)	Jaw's compensation (mm)	Chucking Dia. Max. (mm)	Chucking Dia. Min. (mm)	Max. D.B. pull kN (kgf)	Max. clamping force kN (kgf)	Max. speed min <sup>1</sup> (r.p.m.)	I kg · m <sup>2</sup>	Weight (kg)	Matching cyl.	Max. pressure MPa (kgf/cm <sup>2</sup> )
3J-05	12	8	2	53	25	7.5(765)	6.0(612)	4000	0.02	11	RK-100 OR RK-100(N)	1.0(10)
3J-06	12	8	2	79	55	9.0(918)	7.5(765)	4000	0.04	12	RK-100 OR RK-100(N)	1.2(12)
3J-08	12	8	2	106	75	18.0(1835)	16.5(1680)	3500	0.13	23	RK-100 OR RK-100(N)	2.5(25)
3J-10	12	8	2.5	150	119	18.0(1835)	16.5(1680)	3500	0.3	33	RK-100 OR RK-100(N)	2.5(25)
3J-12	12	8	2.5	200	169	18.0(1835)	16.5(1680)	3000	0.56	44	RK-100 OR RK-100(N)	2.5(25)

#### Dimensions

Model	A	B	C	D	F	G max.	G min.	J	J1	K	L	L1	M Max.	M Min.	N	P	Q	R	S	T	U
3J-05	135	86	110	82.6	40	75	55	25	10	M12X1.75	M10	15	56	36	20	M10	42.5	27	3~M6	50	-
3J-06	165	86	140	104.8	45	75	55	28	14	M16X2	M10	15	56	36	20	M10	57.5	40	3~M8	64	-
3J-08	210	90	170	133.4	56	80	60	38	16	M20X2.5	M12	18	71	51	25	M12	77.5	53.5	6~M8	104	20°
3J-10	254	95	220	171.4	56	75	55	38	16	M20X2.5	M16	24	71	51	25	M12	99.5	75.5	6~M8	140	20°
3J-12	304	95	220	171.4	56	75	55	38	16	M20X2.5	M16	24	71	51	25	M12	124.5	100.5	6~M8	190	20°



#### Application/customer benefits

- 2-Jaw Finger Style with closed center
- Eliminates thin walled workpiece deformation.
- Compensating mechanism allows clamping of material with irregular shapes
- Center stop is available to help center the workpiece

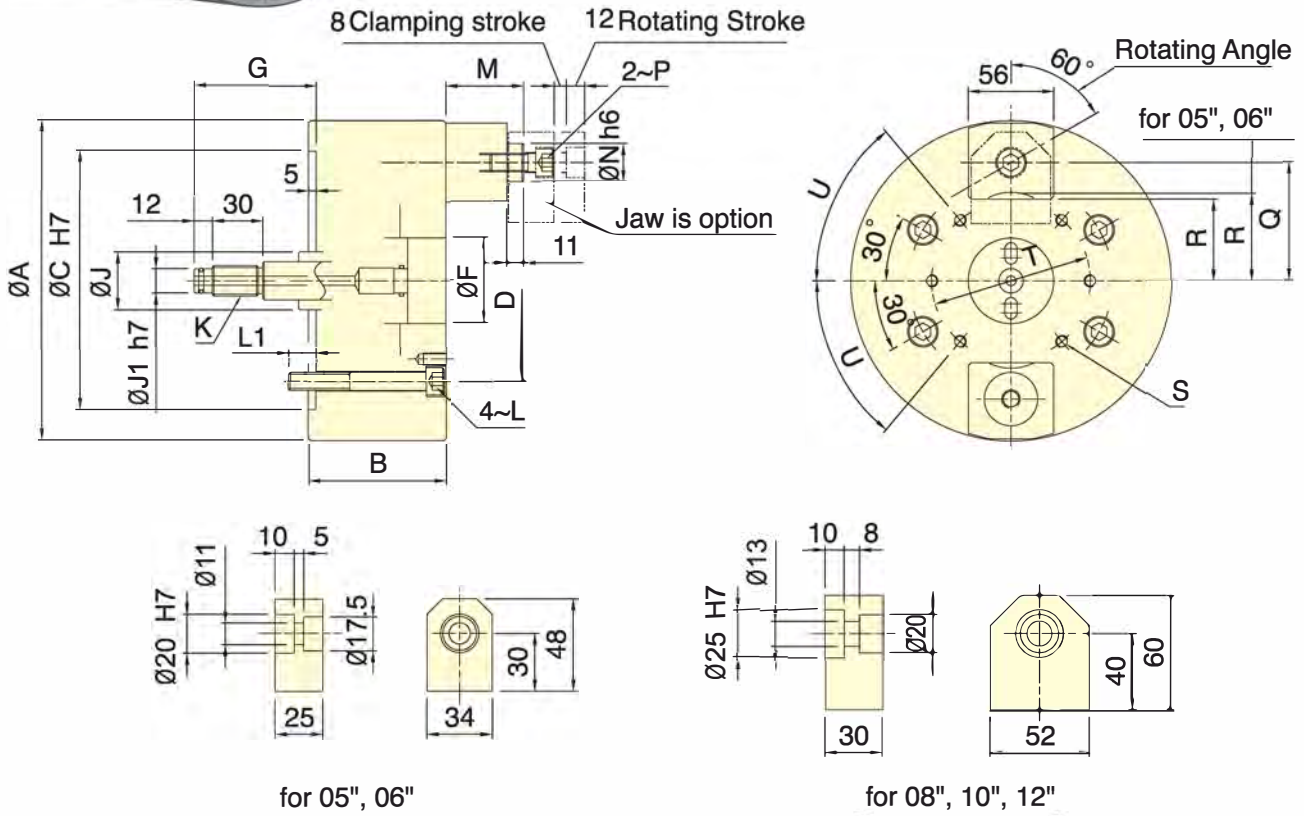

SPECIAL PURPOSE

#### Specifications

Model	Plunger stroke (mm)	Jaw stroke (Dia.) (mm)	Jaw's compensation (mm)	Chucking Dia. Max. (mm)	Chucking Dia. Min. (mm)	Max. D.B. pull kN (kgf)	Max. clamping force kN (kgf)	Max. speed min <sup>-1</sup> (r.p.m.)	I kg · m <sup>2</sup>	Weight (kg)	Matching cyl.	Max. pressure MPa (kgf/cm <sup>2</sup> )
2J-05	12	8	2	53	25	5.0(510)	4.0(408)	4000	0.015	9	RK-100 OR RK-100(N)	0.7(7)
2J-06	12	8	2	79	55	6.0(612)	5.0(510)	4000	0.035	9.8	RK-100 OR RK-100(N)	0.8(8)
2J-08	12	8	2	106	75	12.0(1224)	11.0(1122)	3500	0.12	20.3	RK-100 OR RK-100(N)	1.7(17)
2J-10	12	8	2.5	150	119	12.0(1224)	11.0(1122)	3500	0.28	30.7	RK-100 OR RK-100(N)	1.7(17)
2J-12	12	8	2.5	200	169	12.0(1224)	11.0(1122)	3000	0.52	41.2	RK-100 OR RK-100(N)	1.7(17)

#### Dimensions

Model	A	B	C	D	F	G max.	G min.	J	J1	K	L	L1	M Max.	M Min.	N	P	Q	R	S	T	U
2J-05	135	86	110	82.6	40	75	55	25	10	M12X1.75	M10	15	56	36	20	M10	42.5	27	4~M6	50	30°
2J-06	165	86	140	104.8	45	75	55	28	14	M16X2	M10	15	56	36	20	M10	57.5	40	4~M8	64	30°
2J-08	210	90	170	133.4	56	80	60	38	16	M20X2.5	M12	18	71	51	25	M12	77.5	53.5	6~M8	104	50°
2J-10	254	95	220	171.4	56	75	55	38	16	M20X2.5	M16	24	71	51	25	M12	99.5	75.5	6~M8	140	50°
2J-12	304	95	220	171.4	56	75	55	38	16	M20X2.5	M16	24	71	51	25	M12	124.5	100.5	6~M8	190	50°





### Application/customer benefits

- 3-Jaw Swing / Compensating Power Chuck with closed center
- Compensating feature where the chuck jaws follow the true center (provided through the fixed position of the center thimble) with 2mm total compensation
- Suitable for castings and forgings
- Special seal protects against debris and cutting fluids
- Chuck body and internal parts are hardened and ground for exceptional accuracy and long life

SPECIAL PURPOSE

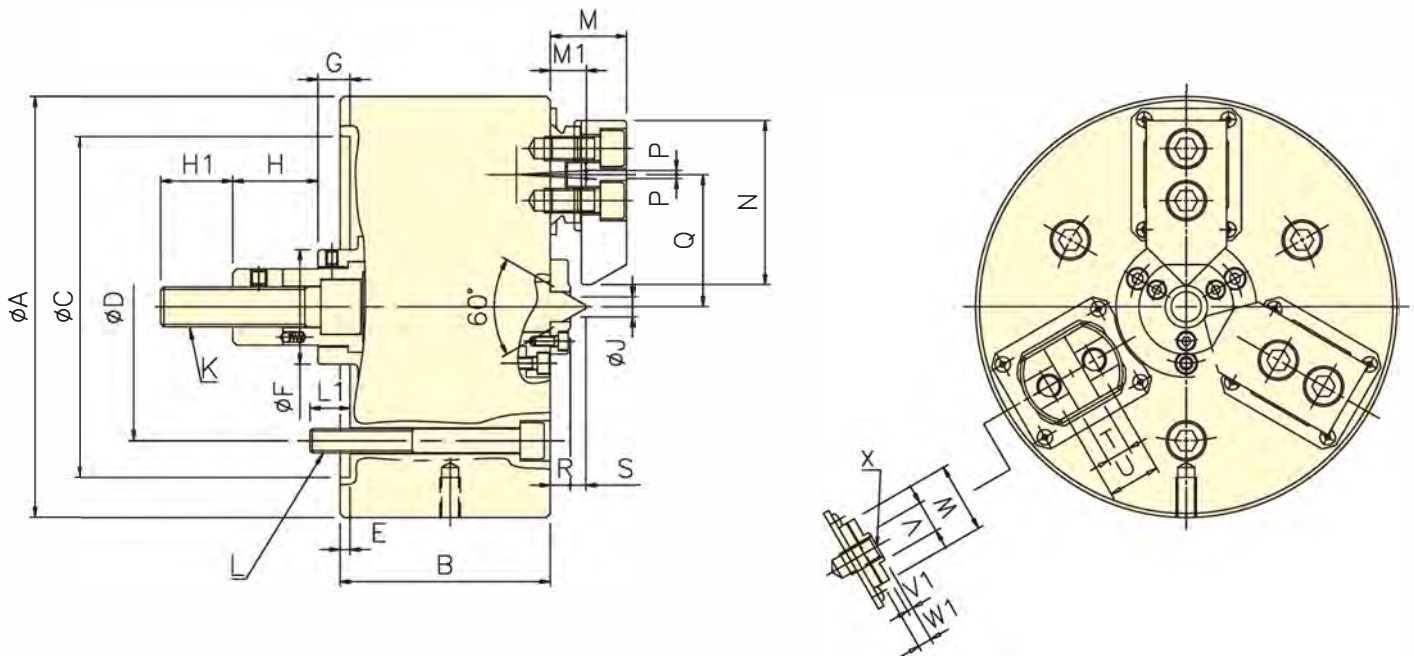

### Specifications

Model	Plunger stroke (mm)	Jaw stroke (Dia.) (mm)	Chucking Dia. Max. (mm)	Chucking Dia. Min. (mm)	Max. D.B. pull kN (kgf)	Max. clamping force kN (kgf)	Max. speed min <sup>-1</sup> (r.p.m.)	I kg · m <sup>2</sup>	Weight (kg)	Matching cyl.	Compensation (mm)
3R-08	20	8	65	18	19.6(1999)	53.0(5404)	2800	0.15	27	RK-100N	2
3R-10	25	10	90	22	29.4(2996)	67.7(6901)	2500	0.38	45	RK-125N	2

### Dimensions

Model	A	B	C (H6)	D	E	F	Gmax.	Gmin.	H	H1	J	K	L	L1	M	M1	N	P	Q max.	Q min.	R	S	T (H7)	U	V	V1	W	W1	X
3R-08	210	105	170	133.4	5	57	26	6	42.5	36	10.4	M20x2.5	3-M12	20	38	18	82	2	68	64	10	7.7	12	26	16	3	35	7	M12
3R-10	254	115	220	171.4	5.5	64	36.5	11.5	25	39	15	M20x2.5	3-M16	22.5	40	19	102	2.6	82	78	10	11.3	15	32	18	3	40	7	M14



### Application/customer benefits

- 3-Jaw Swing type with closed center
- Self centers around the workpiece
- Excellent option for castings and forgings
- Sealed to eliminate dust, debris and cutting fluids
- All internal parts are hardened and precision ground for exceptional accuracy and long life
- 3W-C / Compensating feature where the chuck jaws follow the true center (provided through the fixed position of the center thimble) with 2mm total compensation

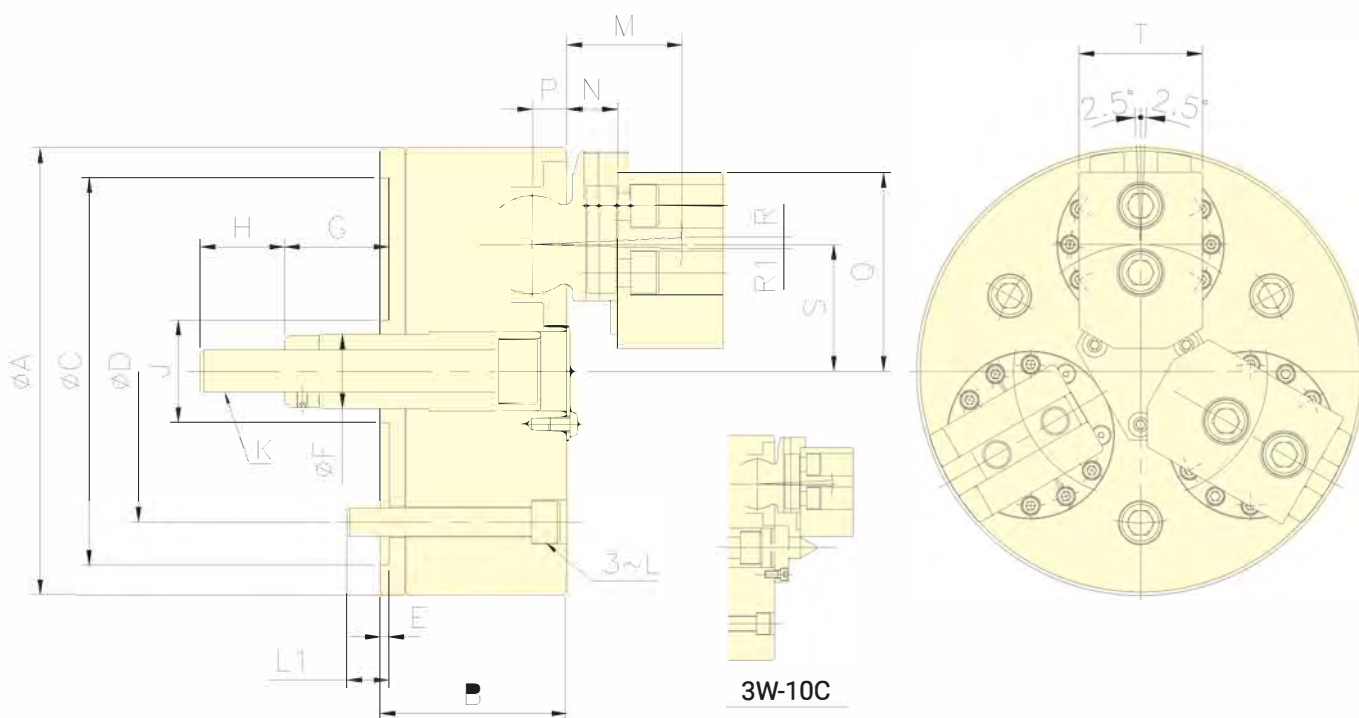

SPECIAL PURPOSE

### Specifications

Model	Plunger stroke (mm)	Jaw stroke (Dia.) (mm)	Chucking Dia. Max. (mm)	Chucking Dia. Min. (mm)	Max. D.B. pull kN (kgf)	Max. clamping force kN (kgf)	Max. speed min <sup>-1</sup> (r.p.m.)	I kg · m <sup>2</sup>	Weight (kg)	Matching cyl.	Compensation (mm)
3W-10	17.5	12.5	205/235	50/85	35.3(3600)	105.9(10800)	2500	0.37	48.6	RK-150N	-
3W-10C	17.5	12.5	205/235	50/85	35.3(3600)	105.9(10800)	2500	0.37	48.6	RK-150N	2

### Dimensions

Model	A	B	C(H7)	D	E	F	Gmax.	Gmin.	H	J	K	L	L1	M	N	P	Q	R	R1	S	T
3W-10	254	106	220	171.4	5	42	67.5	50	48	58	M24x3	M16	24	65.6	29	19.5	113	4.03	2.26	72	70
3W-10C	254	106	220	171.4	5	42	67.5	50	48	58	M24x3	M16	24	65.6	29	19.5	113	4.03	2.26	72	70



Application/customer benefits

- 3-Jaw Quick Change Power Chuck
- Quick change system allows for the shortest change times with precision and high repeatability
- All chuck parts are hardened and precision ground
- High rigidity and clamping accuracy
- Built in safety system to ensure that the quick-change jaws are always in the proper position

SPECIAL PURPOSE

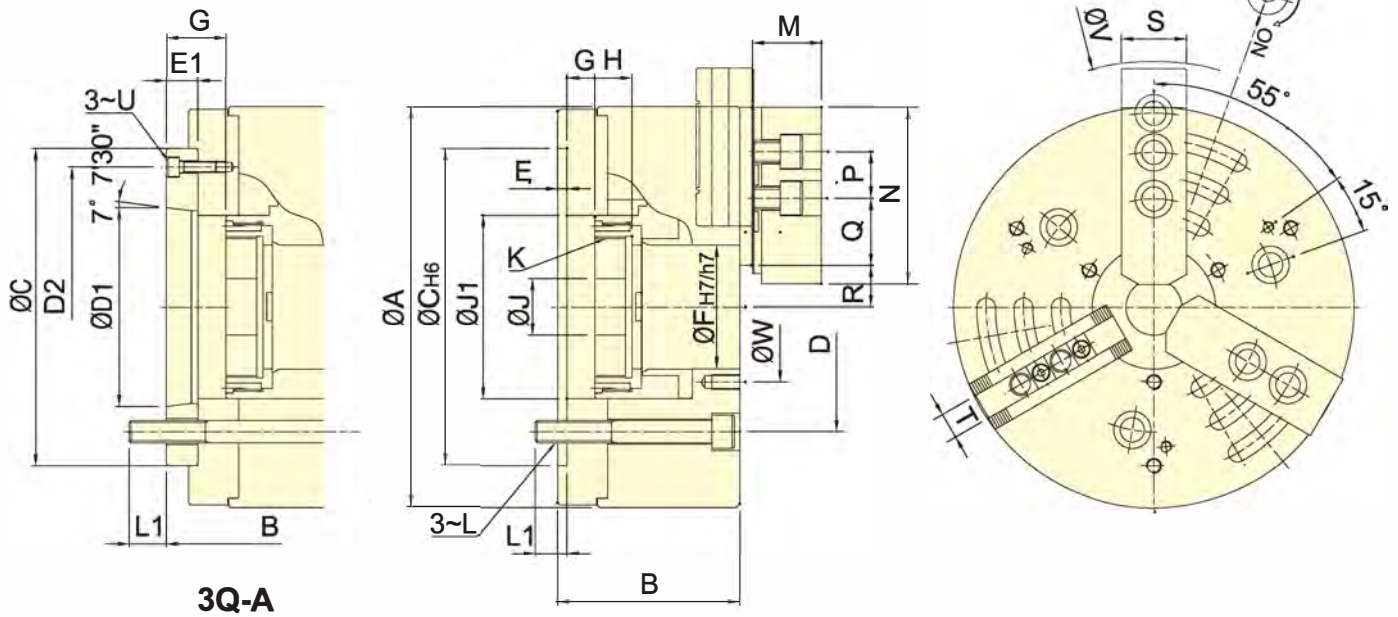

3Q-A

Specifications

Model	Plunger stroke (mm)	Jaw stroke (Dia.) (mm)	Chucking Dia. Max. (mm)	Chucking Dia. Min. (mm)	Max. D.B. pull kN (kgf)	Max. clamping force kN (kgf)	Max. speed min <sup>-1</sup> (r.p.m.)	I kg · m <sup>2</sup>	Weight (kg)	Matching cyl.	Max. pressure MPa (kgf/cm <sup>2</sup> )
* 3Q-08 <b>A6</b>	16	7.5	210	23	45.0(4590)	100.0(10200)	5000	0.15	24.5 <b>26</b>	TK-1068	3.1(31)
* 3Q-10 <b>A8</b>	19	8.8	254	41	60.0(6118)	135.0(13765)	4500	0.41	44 <b>46</b>	TK-1287	2.8(28)
* 3Q-12 <b>A8</b>	23	10.6	315	47	81.0(8259)	180.0(18354)	3500	0.96	73 <b>75</b>	TK-1511	2.4(25)

Dimensions

Model	A	B	B	C	D	D1	D2	E	E1	F	G max.	G min.	G min.	H	J	J1	K	L	L1	L1	M	N	P	Q	R max.	R min.	S	T	U	V	W	
* 3Q-08 <b>A6</b>	215	98	<b>110</b>	170	133.4	<b>106.38</b>	<b>150</b>	5	<b>17</b>	66	14.5	<b>32</b>	-1.5	<b>15.5</b>	20	30	98	M75x2	M12	17	<b>20</b>	37	95	25	36	20.8~44.8	17.1~41.1	35	14	<b>M6</b>	264	80
* 3Q-10 <b>A8</b>	254	119	<b>132</b>	220	171.4	<b>139.72</b>	<b>190</b>	5	<b>18</b>	81	8.5	<b>26.5</b>	-10.5	<b>7.5</b>	39	45	115	M90x2	M16	23	<b>25</b>	42	110	30	40.5	21.1~52.8	16.7~48.2	40	16	<b>M8</b>	312	100
* 3Q-12 <b>A8</b>	315	133	<b>145</b>	220	171.4	<b>139.72</b>	<b>190</b>	6	<b>18</b>	106	8.5	<b>26.5</b>	-14.5	<b>3.5</b>	42	50	140	M115x2	M16	22	<b>24</b>	50	111	30	57	34.1~70.1	28.8~64.8	50	21	<b>M8</b>	360	130

The dimensions and the specifications of 3Q-A type are in the red data.

\*model produced only by order.



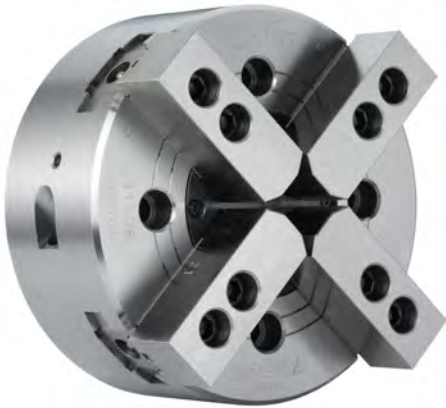

Application/customer benefits

- 4-Jaw Lever style
- 2 jaws self-center and 2 jaws work independently
- Suitable for square bar stock and other non-uniform shaped workpieces

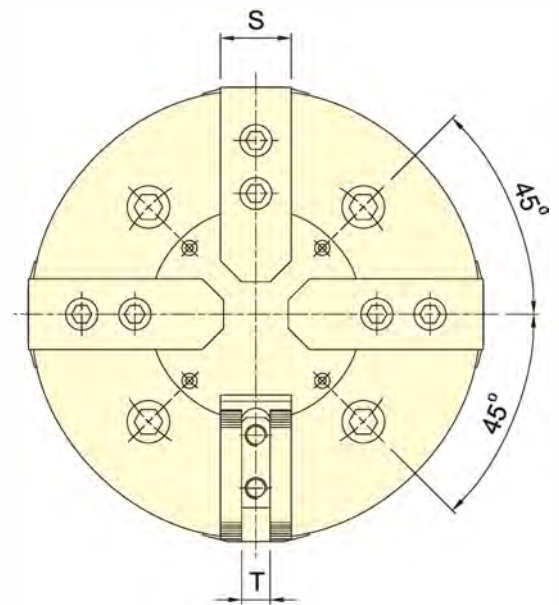
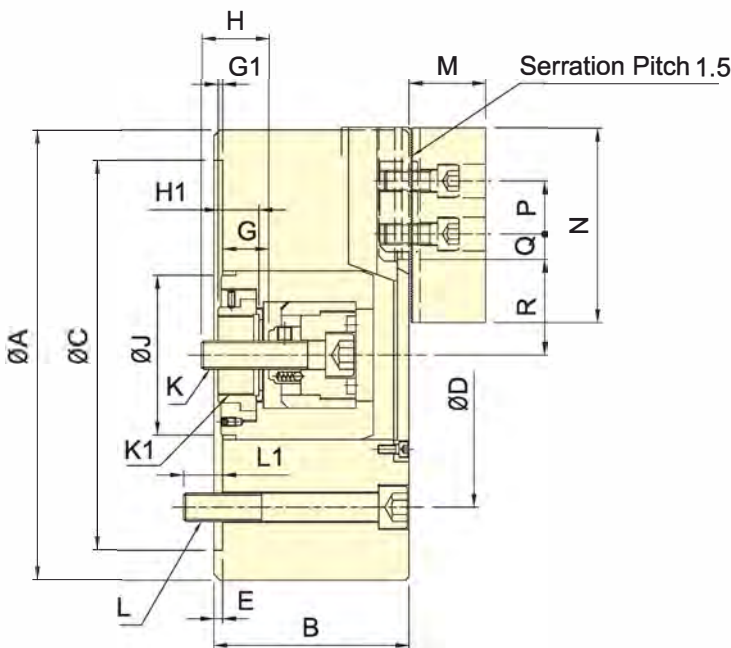

SPECIAL PURPOSE

Specifications

Model	Plunger stroke (mm)	Jaw stroke (Dia.) (mm)	Chucking Dia. Max. (mm)	Chucking Dia. Min. (mm)	Max. D.B. pull kN (kgf)	Max. clamping force kN (kgf)	Max. speed min <sup>-1</sup> (r.p.m.)	I kg · m <sup>2</sup>	Weight (kg)	Matching cyl.	Max. pressure MPa (kgf/cm <sup>2</sup> )
4T-08	17	13.6	210	24	16.0(1630)	54.3(5540)	3000	0.15	23.2	RD-120(N)	1.7(17)
4T-10	20	16	254	50	21.6(2200)	79.4(8100)	2100	0.35	44.3	RD-125(N)	2.2(22)
4T-12	20	16	304	50	21.6(2200)	79.4(8100)	1500	0.66	57.6	RD-125(N)	2.2(22)
4T-15	25	19.6	381	60	27.2(2780)	105.3(10750)	1200	2.25	118.3	RD-125(N)	2.7(27)

Dimensions

Model	A	B	C(H6)	D	E	G max.	G min.	G1 max.	G1 min.	H	H1	J	K	K1	L	L1	M	N	P	Q max.	Q min.	R max.	R min.	S	T
4T-08	210	91	170	133.4	5	32	15	2.5	-14.5	29	20	61	M14x2	M34x1.5	4~M2	20	38	95	25	25.25	13.25	46.1	39.3	35	14
4T-10	254	110	220	171.4	5	36.5	16.5	10	-10	36	23	90	M16x2	M45x1.5	4~M16	25	43	110	30	32.25	12.75	59	51	40	16
4T-12	304	110	220	171.4	5	36.5	16.5	10	-10	36	23	90	M16x2	M45x1.5	4~M16	25	43	110	30	54.75	15.75	59	51	40	16
4T-15	381	135	300	235	6	44.5	19.5	5	-20	45	28	125	M20x2.5	M55x2	4~M20	30	51	130	30	66.5	12.5	78.9	69.1	50	21



### Application/customer benefits

- 3-Jaw large thru-hole air chuck with built in air cylinder
- Patented air supply system provides quick and easy change over

SPECIAL PURPOSE

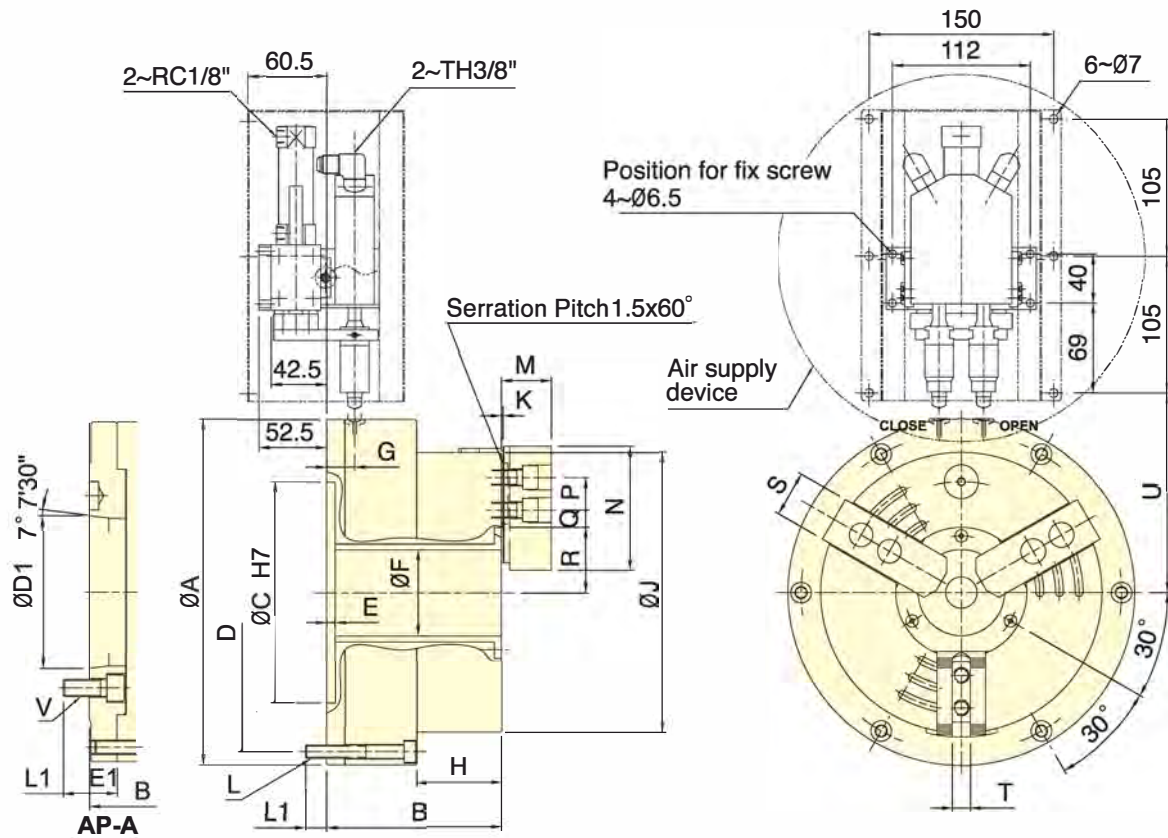

### Specifications

Model	Thru-hole Dia (mm)	Jaw stroke (Dia.) (mm)	Chucking Dia. Max. (mm)	Chucking Dia. Min. (mm)	Max. pressure MPa (kgf/cm <sup>2</sup> )	Max. clamping force kN (kgf)	Max. speed min <sup>-1</sup> (r.p.m.)	I kg · m <sup>2</sup>	Weight (kg)	Air Consumption lit(at 6kgf/cm <sup>2</sup> )
AP-52 <b>A6</b>	52	5.9	170	15	0.6(6.1)	40.4(4118)	4200	0.2	26 <b>27</b>	3.1
AP-66 <b>A6</b>	66	7.6	215	24	0.6(6.1)	51.0(5185)	3500	0.4	38 <b>39</b>	5.1
AP-86 <b>A8</b>	86	8.9	268	43	0.6(6.1)	76.0(7723)	3200	0.7	58 <b>60</b>	8.7
AP-115 <b>A8</b>	115	10.6	330	55	0.6(6.1)	80.0(8155)	3000	1.7	92 <b>95</b>	12

### Dimensions

Model	A	B	C	D	D1	E	E1	F	G	H	J	K	L	L1	L1	M	N	P	Q max.	Q min.	R max.	R min.	S	T	U	V	
AP-52 <b>A6</b>	235	121	<b>140</b>	170	215	<b>106.38</b>	6.5	<b>19</b>	52	21.5	58.5	170	2	6~M10	15	<b>18</b>	37	73	20	21.2	9.2	38	35.1	31	12	145.5	6~M12
AP-66 <b>A6</b>	265	134	<b>153</b>	170	245	<b>106.38</b>	6.5	<b>19</b>	66	21.5	65	215	2	6~M10	16	<b>18</b>	38	95	25	23.7	8.7	50.2	46.4	35	14	159.5	6~M12
AP-86 <b>A8</b>	315	142	<b>169</b>	220	295	<b>139.72</b>	6.5	<b>27</b>	86	21.5	67	268	2	6~M10	16	<b>24</b>	43	110	30	32.2	12.7	62.2	57.8	40	16	184.5	6~M16
AP-115 <b>A8</b>	370	154	<b>181</b>	220	350	<b>139.72</b>	6.5	<b>27</b>	115	21.5	69	330	2	6~M10	16	<b>24</b>	51	130	30	44.7	14.7	77	71.7	50	21	212	6~M16

The dimensions and the specifications of AP-A type are in the red data.

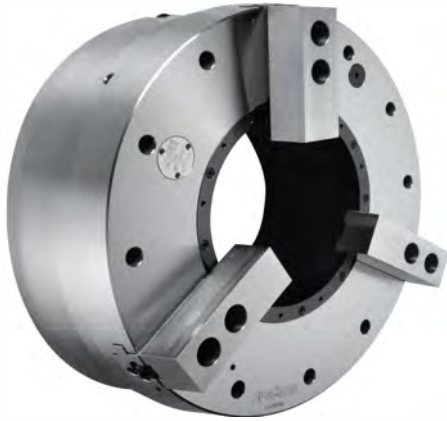

### Application/customer benefits

- 3-Jaw large thru-hole air chuck with built in air cylinder
- Built in "pressure detection" device that detects low pressure
- Patented air supply system provides quick and easy change over

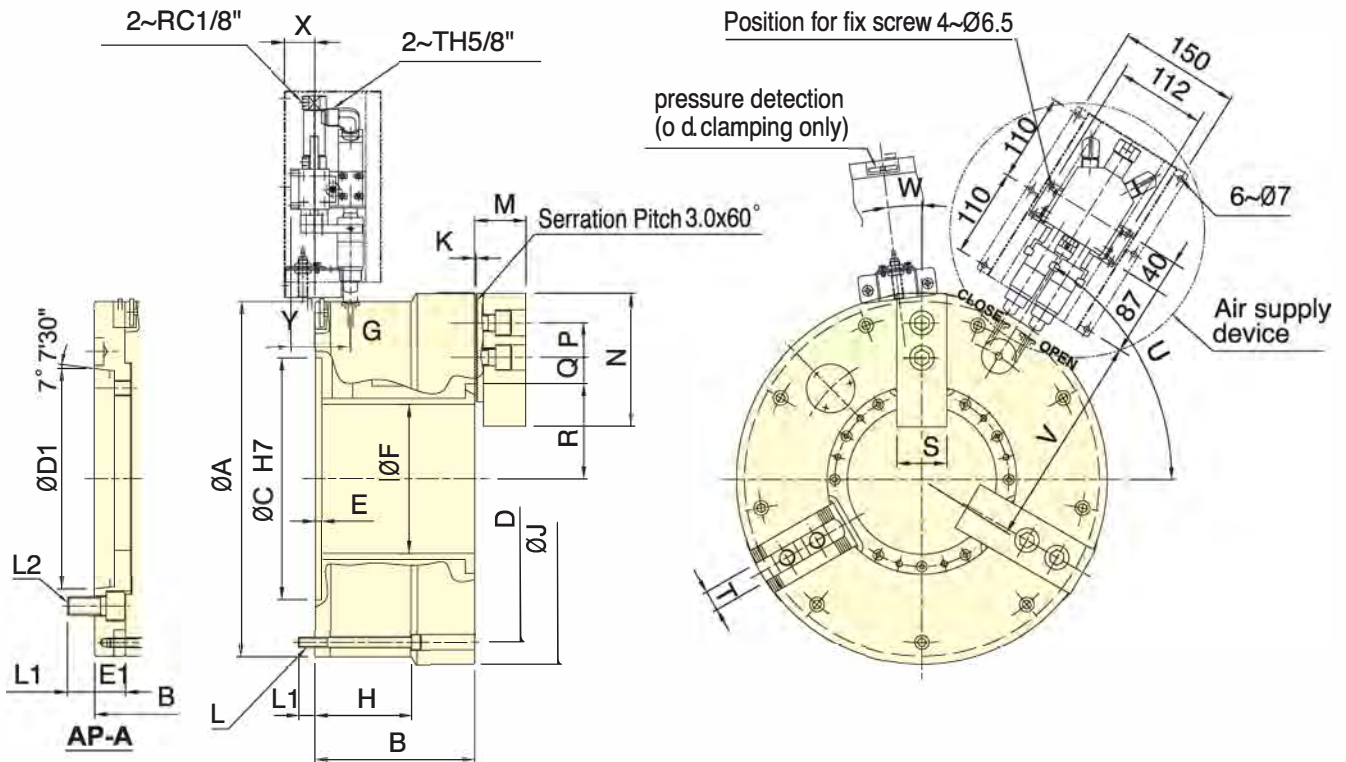

SPECIAL PURPOSE

### Specifications

Model	Thru-hole Dia (mm)	Jaw stroke (Dia.) (mm)	Chucking Dia. Max. (mm)	Chucking Dia. Min. (mm)	Max. pressure MPa (kgf/cm <sup>2</sup> )	Max. clamping force kN (kgf)	Max. speed min <sup>-1</sup> (r.p.m.)	I kg · m <sup>2</sup>	Weight (kg)	Air Consumption lit(at 6kgf/cm <sup>2</sup> )
AP-145 <b>A11</b>	145	14	420	62	0.6(6.1)	85.0(8667)	1700	3.8	156 <b>182</b>	17.8
AP-185 <b>A15</b>	185	14	460	100	0.6(6.1)	110.0(11216)	1300	6	188 <b>223</b>	22
AP-230 <b>A15</b>	230	17	535	170	0.6(6.1)	125.0(12742)	1300	11.1	265 <b>310</b>	34
AP-275 <b>A20</b>	275	17	580	200	0.6(6.1)	140.0(14271)	1100	15.5	301 <b>346</b>	39
AP-320 <b>A20</b>	320	17	658	200	0.6(6.1)	184.0(18762)	1000	27.2	415 <b>505</b>	45
AP-375 <b>A20</b>	375	24	738	260	0.6(6.1)	188.0(19115)	850	44.2	530 <b>545</b>	55

### Dimensions

Model	A	B	C	D	D1	E	E1	F	G	H	J	K	L	L1	L2	M	N	P	Q max.	Q min.	R max.	R min.	S	T	U	V	W	X	Y		
AP-145 <b>A11</b>	400	198	<b>231</b>	300	365	<b>196.87</b>	8	<b>33</b>	145	34	120	420	3.5	9~M12	20	<b>31</b>	<b>6~M20</b>	63.7	165	43	53.5	23.5	98	91	62	25.5	57°	242	0°	38	20
AP-185 <b>A15</b>	460	198	<b>238</b>	300	405	<b>285.78</b>	8	<b>40</b>	185	44	120	460	3.5	9~M12	20	<b>35</b>	<b>6~M24</b>	63.7	165	43	53.5	23.5	118	111	62	25.5	58°	272	7°	38	20
AP-230 <b>A15</b>	515	226	<b>266</b>	380	483	<b>285.78</b>	8	<b>40</b>	230	49	145	535	3.5	6~M16	24	<b>35</b>	<b>6~M24</b>	71.7	180	60	48.5	18.5	145	136.5	64	25.5	30°	300	7°	33	15
AP-275 <b>A20</b>	560	232	<b>272</b>	380	528	<b>412.78</b>	8	<b>40</b>	275	52	152	580	3.5	6~M16	24	<b>35</b>	<b>6~M24</b>	71.7	180	60	48.5	18.5	167.5	159	64	25.5	30°	322	7°	30	12
AP-320 <b>A20</b>	615	256	<b>306</b>	520	580	<b>412.78</b>	8	<b>50</b>	320	55	116.5	658	3.5	9~M16	25	<b>33</b>	<b>6~M24</b>	81.5	210	60	60.5	24.5	190	181.5	74	30	52°	350	7°	27	9
AP-375 <b>A20</b>	690	272	<b>322</b>	520	650	<b>412.78</b>	8	<b>50</b>	375	55	127	738	3.5	9~M16	28	<b>33</b>	<b>6~M24</b>	81.5	210	60	66.5	24.5	223.5	211.5	74	30	52°	387	7°	27	9

The dimensions and the specifications of AP-A type are in the red data.



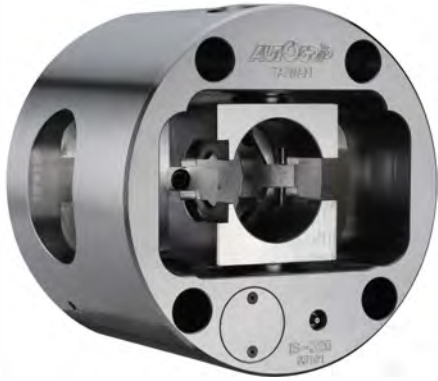

## Application/customer benefits

- Indexing operates during spindle rotation providing quick change over between multiple operations
- Chuck and all parts are hardened, ground and lubricated.
- Sealed against swarf and chips
- High rigidity and precision
- Unique indexing and hydraulic system with pressure detection provides reliability and safety

SPECIAL PURPOSE

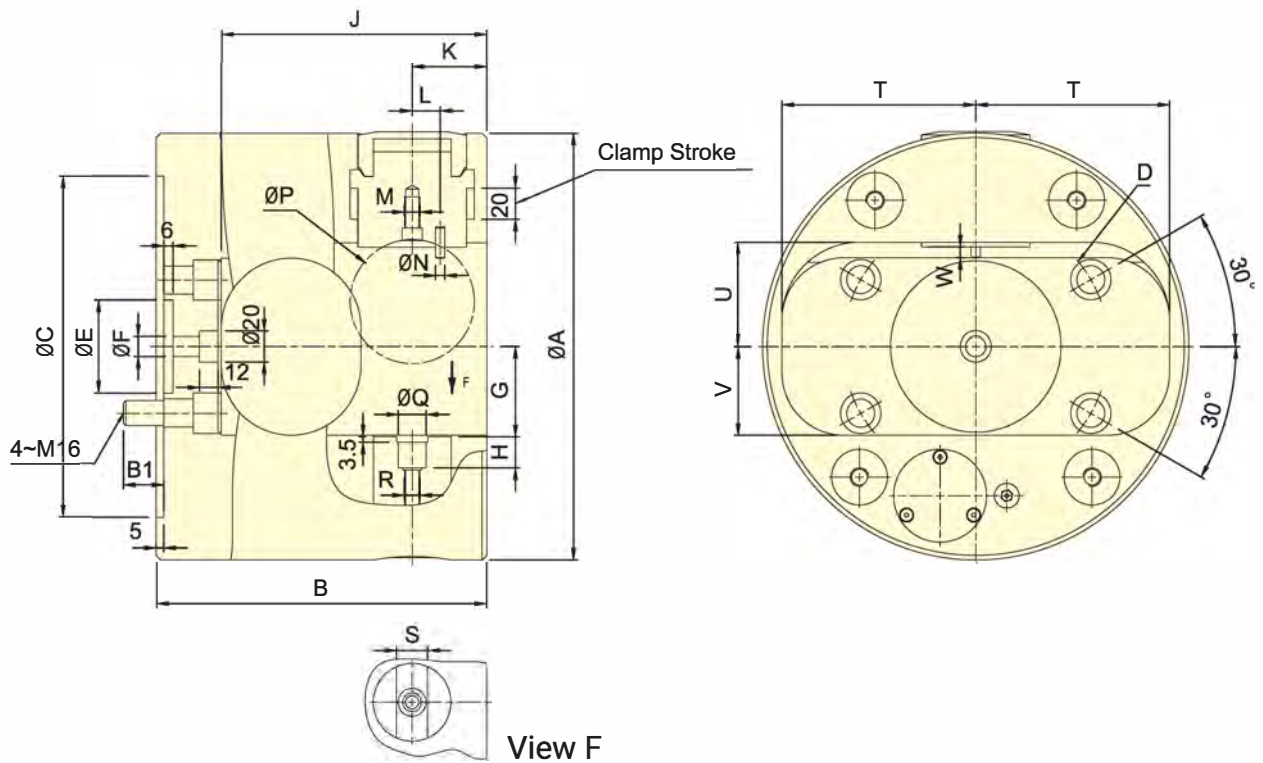

## Specifications

Model	Index Angle Deg	Jaw stroke (Dia.)(mm)	Chucking Area Dia Max. (mm)	Chucking Area Len Max. (mm)	Max. pressure (kgf/cm <sup>2</sup> )	Max. clamping force kN(kgf)	Max. speed min <sup>-1</sup> (r.p.m.)	I kg · m <sup>2</sup>	Weight (kg)	ROTATING JOINT	Main Spindle Bore (mm)
* IS-254	8x45,4x90	20	65	160	45	19.5(1990)	2400	0.41	41	IS-315	86+0.1
* IS-275	8x45,4x90	20	80	220	45	25.4(2590)	2000	0.61	52	IS-315	86+0.1
* IS-315	8x45,4x90	20	100	230	45	25.0(2550)	1800	1.13	76	IS-315	86+0.1

## Dimensions

Model	A	B	B1	C(H6)	D	E	F	G	H	J	K	L	M	N	P	Q(H7)	R	S(H7)	T	U	V	W
* IS-254	254	190	23	220	171.4	60	13	47.5	18	155	48	13	M8	5	40	18	M10	20	106	57	46.5	5.5
* IS-275	275	213	26	220	171.4	60	13	58	20	171	48	18	M10	6	80	18	M10	20	125	67	57	7
* IS-315	315	232	22	220	171.4	60	13	71	18.5	187	50	18	M10	6	75	24	M12	25	125	85	70	7.5

\*model produced only by order.



### Application/customer benefits

- Push type collet chuck for CNC and special purpose applications
- High speed with high rigidity and clamping accuracy
- Easy replacement of “standard” thru-hole power chucks utilizing the same draw tube
- Sealed against swarf, chips and coolant
- Uses DIN 6343 collets

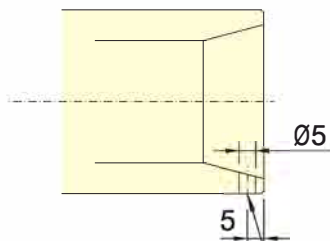

The hole and lock pin is option.  
Note: While clamp square or hexagonal material, please order hole and lock pin of collet chuck.

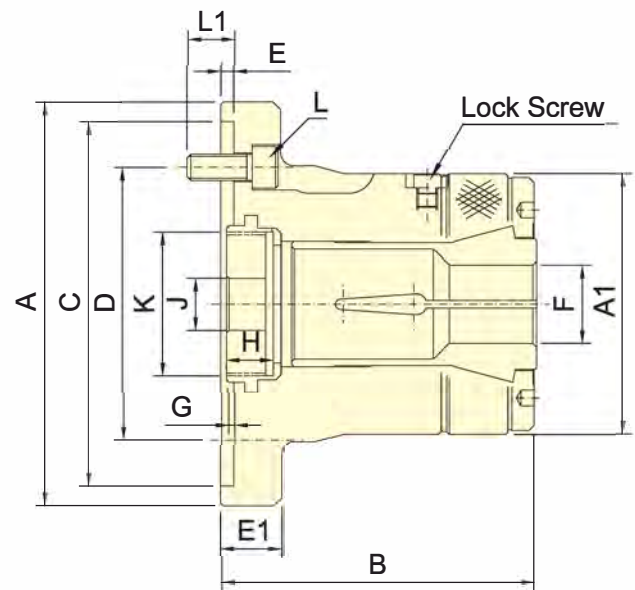

### Specifications

Model	Plunger stroke (mm)	Max. Chucking Capacity (mm)			Max. D.B. pull kN (kgf)	Max. clamping force kN(kgf)	Max. speed min <sup>-1</sup> (r.p.m.)	I kg · m <sup>2</sup>	Weight (kg)	Matching Stell Collet	Matching cyl.	Max. pressure MPa (kgf/cm <sup>2</sup> )
		Round	Hexagom	Square								
CL-26	4.5	3~26	4~22	4~18	17.6(1800)	37.9(3870)	8000	0.04	4.3	161E	TK-A533	2.6(26)
CL-30	4.5	3~30	4~26	4~20	19.6(2000)	42.1(4300)	8000	0.038	4.2	163E	TK-A533	2.9(29)
CL-36	6	3~36	6~32	6~26	22.5(2300)	48.5(4950)	6000	0.062	7	171E	TK-C643	2.5(25)
C L-42	6	3~42	6~36	6~29	24.5(2500)	52.9(5400)	6000	0.06	6.9	173E	TK-C643	2.9(29)
CL-52	6	5~52	8~45	7~36	27.4(2800)	59.0(6020)	6000	0.101	14.3	177E	TK-A853	2.3(23)
CL-6017	6	5~60	8~52	7~42	29.4(3000)	63.7(6500)	5000	0.098	14.1	185E	TK-1068	1.8(18)
CL-6022	6	5~60	8~52	7~42	29.4(3000)	63.7(6500)	5000	0.126	16.3	185E	TK-1068	1.8(18)
CL-80	6	20~80	18~69	15~56	34.3(3500)	71.5(7300)	4000	0.108	17.8	193E	TK-1287	1.6(16)

### Dimensions

Model	A	A1	B	C(H6)	D	E	E1	F max.	F min.	G max.	G min.	H	J	K max.	L	L1
CL-26	120	85	100	110	82.6	4	23	26	3	7	2.5	15	12	M40x1.5	3~M10x25	16
CL-30	120	85	100	110	82.6	4	23	30	3	7	2.5	15	12	M40x1.5	3~M10x25	16
CL-36	155	100	120	140	104.8	5	23	36	3	7	1	17.5	20	M55x2	3~M10x25	18
CL-42	155	100	120	140	104.8	5	23	42	3	7	1	17.5	20	M55x2	3~M10x25	18
CL-52	185	130	145.5	170	133.4	5	27	52	5	9	3	24	45	M60x2	6~M12x30	20
CL-6017	185	130	145.5	170	133.4	5	27	60	5	9	3	24	45	M75x2	6~M12x30	20
CL-6022	234	130	142	220	171.5	5	32	60	5	13	7	24	45	M85x2	6~M16x30	20
CL-80	234	156	163	220	171.5	5	32	80	20	15.5	9.5	22	45	M100x2	6~M16x30	20

COLLET CHUCKS



Application/customer benefits

- Push type collet chuck for CNC and special purpose applications
- High speed with high rigidity and clamping accuracy
- Easy replacement of “standard” thru-hole power chucks utilizing the same draw tube
- Sealed against swarf, chips and coolant
- Uses DIN 6343 collets

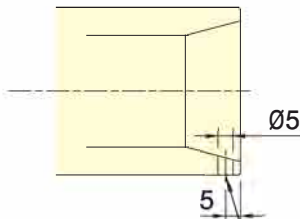

The hole and lock pin is option.  
Note: While clamp square or hexagonal material, please order hole and lock pin of collet chuck.

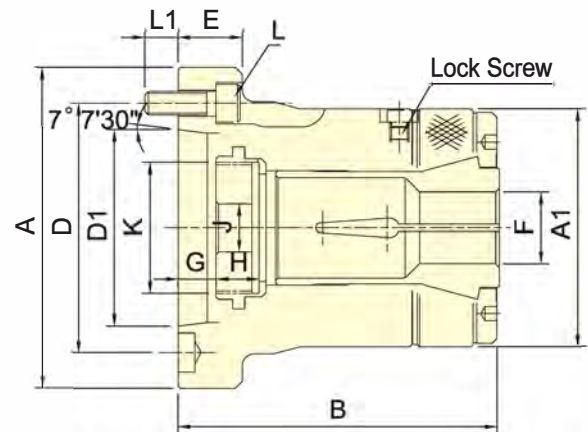

COLLET CHUCKS

Specifications

Model	Plunger stroke (mm)	Max. Chucking Capacity (mm)			Max. D.B. pull kN (kgf)	Max. clamping force kN (kgf)	Max. speed min <sup>-1</sup> (r.p.m.)	I kg · m <sup>2</sup>	Weight (kg)	Matching Stell Collet	Matching cyl.	Max. pressure MPa (kgf/cm <sup>2</sup> )
		Round	Hexagom	Square								
CL-26 A4	4.5	3~26	4~22	4~18	17.6(1800)	37.9(3870)	8000	0.04	4.2	161E	TK-A533	2.6(26)
CL-30 A4	4.5	3~30	4~26	4~20	19.6(2000)	42.1(4300)	8000	0.038	4.1	163E	TK-A533	2.9(29)
CL-36 A5	6	3~36	6~32	6~26	22.5(2300)	48.5(4950)	6000	0.058	6.3	171E	TK-C643	2.5(25)
CL-42 A5	6	3~42	6~36	6~29	24.5(2500)	52.9(5400)	6000	0.057	6.1	173E	TK-C643	2.9(29)
CL-42 A6	6	3~42	6~36	6~29	24.5(2500)	52.9(5400)	6000	0.061	7.5	173E	TK-C643	2.9(29)
CL-52 A6	6	5~52	8~45	7~36	27.4(2800)	59.0(6020)	6000	0.093	13.8	177E	TK-A853	2.3(23)
CL-60 A6	6	5~60	8~52	7~42	29.4(3000)	63.7(6500)	5000	0.091	13.5	185E	TK-1068	1.8(18)
CL-60 A8	6	5~60	8~52	7~42	29.4(3000)	63.7(6500)	5000	0.104	14.5	185E	TK-1068	1.8(18)
CL-80 A8	6	20~80	18~69	15~56	34.3(3500)	71.5(7300)	4000	0.12	19.8	193E	TK-1287	1.6(16)

Dimensions

Model	A	A1	B	D	D1	E	F max.	F min.	G max.	G min.	H	J	K max.	L	L1
CL-26 A4	110	85	108	82.6	63.51	25	26	3	9.5	5	15	12	M40x1.5	3~M10x30	15
CL-30 A4	110	85	108	82.6	63.51	25	30	3	9.5	5	15	12	M40x1.5	3~M10x30	15
CL-36 A5	135	100	130	104.8	82.56	27	36	3	14	8	17.5	20	M55x2	4~M10x30	14
CL-42 A5	135	100	130	104.8	82.56	27	42	3	14	8	17.5	20	M55x2	4~M10x30	14
CL-42 A6	165	100	130	133.4	106.38	32	42	3	17	11	17.5	20	M60x2	4~M12x35	16
CL-52 A6	170	130	154	133.4	106.38	27	52	5	10.5	4.5	24	45	M60x2	4~M12x35	20
CL-60 A6	170	130	154	133.4	106.38	27	60	5	10.5	4.5	24	45	M75x2	4~M12x35	20
CL-60 A8	210	130	147.5	171.5	139.72	35	60	5	3.5	-2.5	24	45	M85x2	4~M16x40	22
CL-80 A8	210	156	175	171.5	139.72	35	80	20	7.5	1.5	22	45	M100x2	6~M16x40	22





### Application/customer benefits

- Draw type collet chuck for CNC and special purpose applications
- High speed with high rigidity and clamping accuracy
- Easy replacement of “standard” thru-hole power chucks utilizing the same draw tube
- Completely sealed design preventing coolant and chips from entering the spindle
- Uses DIN 6343 collets

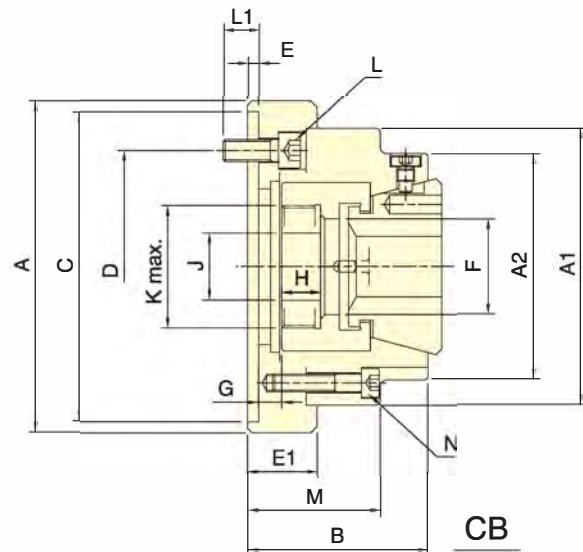
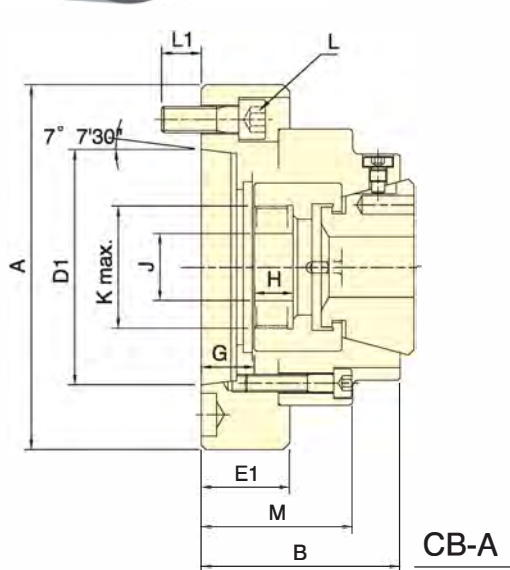

### Specifications

Model	Plunger stroke (mm)	Max. Chucking Capacity (mm)			Max. D.B. pull kN (kgf)	Max. clamping force kN (kgf)	Max. speed min <sup>-1</sup> (r.p.m.)	Weight (kg)	Matching Stell Collet	Matching cyl.	Max. pressure MPa (kgf/cm <sup>2</sup> )
		Round	Square	Hexagom							
CB-42	4.5	4~42	7~30	7~36	34.3(3500)	78.4(8000)	7000	6.5	RG-42	TK-B846	2.8(28)
CB-42 A5	4.5	4~42	7~30	7~36	34.3(3500)	78.4(8000)	7000	6.2	RG-42	TK-B846	2.8(28)
CB-42 A6	4.5	4~42	7~30	7~36	34.3(3500)	78.4(8000)	7000	7.4	RG-42	TK-B846	2.8(28)
CB-52	4.5	4~52	7~36	7~45	39.2(4000)	92.1(9400)	7000	6	RG-52	TK-A853	3.2(32)
CB-5217	4.5	4~52	7~36	7~45	39.2(4000)	92.1(9400)	7000	9.6	RG-52	TK-A853	3.2(32)
CB-52 A5	4.5	4~52	7~36	7~45	39.2(4000)	92.1(9400)	7000	6.5	RG-52	TK-A853	3.2(32)
CB-52 A6	4.5	4~52	7~36	7~45	39.2(4000)	92.1(9400)	7000	7.8	RG-52	TK-A853	3.2(32)
CB-65	4.5	4~65	8~46	8~56	44.1(4500)	103(10500)	5500	15	RG-65	TK-1068	3.0(30)
CB-65 A6	4.5	4~65	8~46	8~56	44.1(4500)	103(10500)	5500	13.6	RG-65	TK-1068	3.0(30)
CB-65 A8	4.5	4~65	8~46	8~56	44.1(4500)	103(10500)	5500	17.6	RG-65	TK-1068	3.0(30)
CB-80	6	5~80	8~56	8~68	50.0(5100)	115(11730)	5500	19	RG-80	TK-1287	2.3(23)
CB-80 A8	6	5~80	8~56	8~68	50.0(5100)	115(11730)	5500	19	RG-80	TK-1287	2.3(23)

### Dimensions

Model	A	A1	A2	B	C(H6)	D	D1	E	E1	F	G max.	G min.	H	J	K max.	L	L1	M	N
CB-42	150	125	102	81.5	140	104.8	-	5	31	43	10.5	6	17.5	30	M55x2	3~M10x25	11	60	4~M8
CB-42 A5	140	125	102	91.5	-	104.8	82.56	-	41.5	43	25.5	21	17.5	30	M55x2	4~M10x25	12	70	4~M8
CB-42 A6	165	125	102	91.5	-	133.4	106.38	-	45	43	29	24.5	17.5	30	M55x2	4~M12x35	18	73.5	4~M8
CB-52	150	125	102	83.5	140	104.8	-	5	31.5	53	11	6.5	17.5	30	M60x2	4~M10x25	16	62.5	4~M8
CB-5217	180	125	102	87	170	133.4	-	5	35	53	14.5	10	17.5	30	M60x2	4~M12x30	18	66	4~M8
CB-52 A5	140	125	102	93.5	-	104.8	82.56	-	41.5	53	26	21.5	17.5	30	M60x2	4~M10x30	16	72.5	4~M8
CB-52 A6	165	125	102	99	-	133.4	106.38	-	47	53	31.5	27	17.5	30	M60x2	6~M12x35	18	78	4~M8
CB-65	185	145	120	100	170	133.4	-	6	50	66	13.5	9	21.5	32	M75x2	6~M12x40	20	73.5	4~M8
CB-65 A6	165	145	120	111	-	133.4	106.38	-	61	66	30.5	26	21.5	32	M75x2	4~M12x40	20	84.5	4~M8
CB-65 A8	207	145	120	107	-	171.4	139.72	-	57	66	26.5	22	21.5	32	M75x2	4~M16x40	24	80.5	4~M8
CB-80	235	175	150	112	220	171.4	-	5	37	82.5	14	8	25	32	M85x2	6~M16x30	22	87	6~M10
CB-80 A8	210	175	150	125	-	171.4	139.72	-	50	82.5	27	21	25	32	M85x2	6~M16x50	24	100	6~M10



**Application/customer benefits**

- Draw type collet chuck for CNC and special purpose applications
- Collet does not move during clamping
- Backgauge stop mechanism allow for precise positioning of the workpiece length
- High speed with high rigidity and clamping accuracy
- Easy replacement of “standard” thru-hole power chucks utilizing the same draw tube
- Completely sealed design preventing coolant and chips from entering the spindle
- Uses DIN 6343 collets

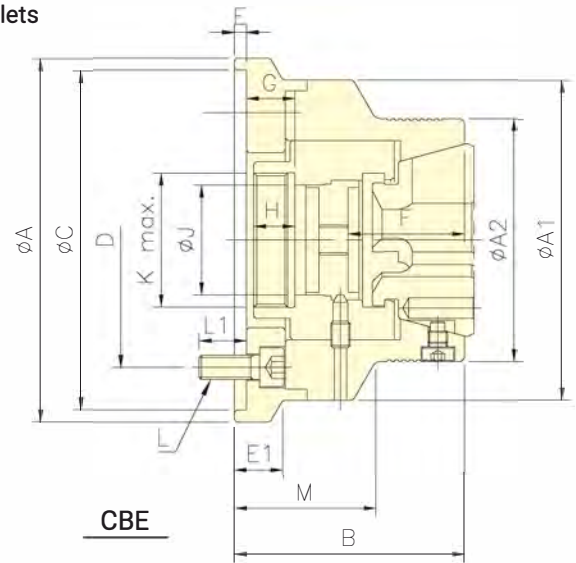
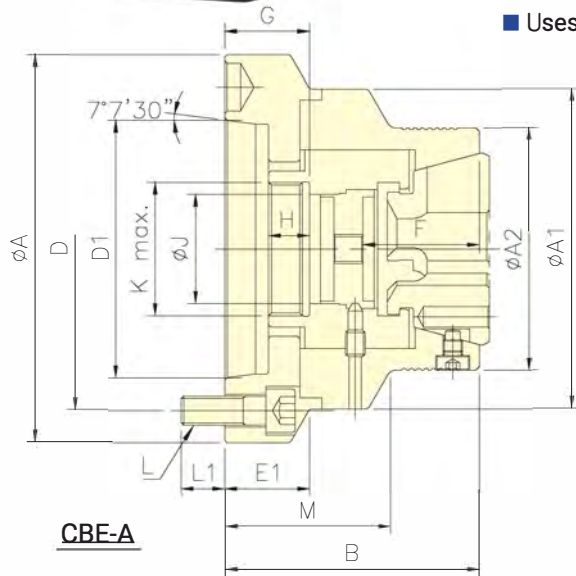

**Specifications**

Model	Plunger stroke (mm)	Max. Chucking Capacity (mm)			Max. D.B. pull kN (kgf)	Max. clamping force kN (kgf)	Max. speed $\text{min}^{-1}$ (r.p.m.)	Weight (kg)	Matching Stell Collet	Matching cyl.	Max. pressure MPa (kgf/cm <sup>2</sup> )
		Round	Square	Hexagom							
CBE-42	4.5	4~42	7~30	7~36	34.3(3500)	78.4(8000)	7000	6	RG-42	TK-B846	2.8(28)
CBE-4212	4.5	4~42	7~30	7~36	34.3(3500)	78.4(8000)	7000	6	RG-42	TK-B846	2.8(28)
CBE-42A5	4.5	4~42	7~30	7~36	34.3(3500)	78.4(8000)	7000	6.3	RG-42	TK-B846	2.8(28)
CBE-42A6	4.5	4~42	7~30	7~36	34.3(3500)	78.4(8000)	7000	7.4	RG-42	TK-B846	2.8(28)
CBE-65	4.5	4~65	8~46	8~56	44.1(4500)	103(10500)	6000	9.3	RG-65	TK-1068	3.0(30)
CBE-6517	4.5	4~65	8~46	8~56	44.1(4500)	103(10500)	6000	8.6	RG-65	TK-1068	3.0(30)
CBE-65A5	4.5	4~65	8~46	8~56	44.1(4500)	103(10500)	6000	10.8	RG-65	TK-1068	3.0(30)
CBE-65A6	4.5	4~65	8~46	8~56	44.1(4500)	103(10500)	6000	9.5	RG-65	TK-1068	3.0(30)
CBE-65A8	4.5	4~65	8~46	8~56	44.1(4500)	103(10500)	6000	9.5	RG-65	TK-1068	3.0(30)

**Dimensions**

Model	A	A1	A2	B	C(H6)	D	D1	E	E1	F	G max.	G min.	H	J	K max.	L	L1	M
CBE-42	150	132	100	95	140	104.8	-	5	20	48	27.5	23	17	45	M55x2	4~M10x25	19.5	58
CBE-4212	132	132	100	95	120	100	-	5	-	48	27.5	23	17	45	M55x2	4~M10x25	19.5	58
CBE-42A5	132	132	100	105	-	104.8	82.56	-	-	48	37.5	33	17	45	M55x2	4~M10x30	16	68
CBE-42A6	160	132	100	105	-	133.4	106.38	-	35	48	37.5	33	17	45	M55x2	4~M12x35	18	68
CBE-65	157	157	122	116	140	104.8	-	6	-	56	40.5	36	17.5	68	M75x2	4~M10x30	18	74
CBE-6517	180	157	122	114	170	133.4	-	6	24	56	40.5	36	17.5	68	M75x2	4~M12x30	18	72
CBE-65A5	157	157	122	114	-	104.8	82.56	-	-	56	38.5	34	17.5	68	M75x2	4~M10x25	16	72
CBE-65A6	157	157	122	112	-	133.4	106.38	-	-	56	36.5	32	17.5	68	M75x2	4~M12x35	18.5	70
CBE-65A8	202	157	122	116	-	171.4	139.72	-	38	56	36.5	32	17.5	68	M75x2	4~M16x35	24	74

COLLET CHUCKS



### Application/customer benefits

- Draw type collet chuck for CNC and special purpose applications
- Collet does not move during clamping
- Backgauge stop mechanism allow for precise positioning of the workpiece length
- High speed with high rigidity and clamping accuracy
- Easy replacement of “standard” thru-hole power chucks utilizing the same draw tube
- Completely sealed design preventing coolant and chips from entering the spindle
- Uses DIN 6343 collets

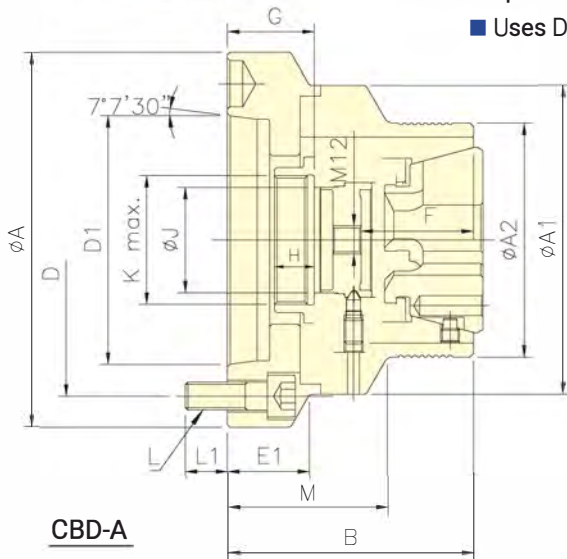

CBD-A

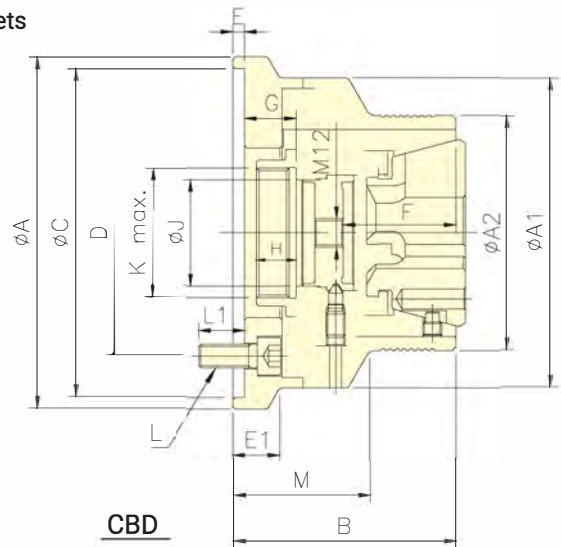

CBD

### Specifications

Model	Plunger stroke (mm)	Max. Chucking Capacity (mm)			Max. D.B. pull kN (kgf)	Max. clamping force kN (kgf)	Max. speed $\text{min}^{-1}$ (r.p.m.)	Weight (kg)	Matching Stell Collet	Matching cyl.	Max. pressure MPa (kgf/cm <sup>2</sup> )
		Round	Square	Hexagom							
CBD-42	4.5	4~42	7~30	7~36	34.3(3500)	78.4(8000)	7000	6	RG-42	TK-B846	2.8(28)
CBD-4212	4.5	4~42	7~30	7~36	34.3(3500)	78.4(8000)	7000	6	RG-42	TK-B846	2.8(28)
CBD-42A5	4.5	4~42	7~30	7~36	34.3(3500)	78.4(8000)	7000	6.3	RG-42	TK-B846	2.8(28)
CBD-42A6	4.5	4~42	7~30	7~36	34.3(3500)	78.4(8000)	7000	7.4	RG-42	TK-B846	2.8(28)
CBD-65	4.5	4~65	8~46	8~56	44.1(4500)	103(10500)	6000	9.3	RG-65	TK-1068	3.0(30)
CBD-6517	4.5	4~65	8~46	8~56	44.1(4500)	103(10500)	6000	8.6	RG-65	TK-1068	3.0(30)
CBD-65A5	4.5	4~65	8~46	8~56	44.1(4500)	103(10500)	6000	10.8	RG-65	TK-1068	3.0(30)
CBD-65A6	4.5	4~65	8~46	8~56	44.1(4500)	103(10500)	6000	9.5	RG-65	TK-1068	3.0(30)
CBD-65A8	4.5	4~65	8~46	8~56	44.1(4500)	103(10500)	6000	9.5	RG-65	TK-1068	3.0(30)

### Dimensions

Model	A	A1	A2	B	C(H6)	D	D1	E	E1	F	G max.	G min.	H	J	K max.	L	L1	M
CBD-42	150	132	100	95	140	104.8	-	5	20	48	24	19.5	17	45	M55x2	4~M10x25	19.5	58
CBD-4212	132	132	100	95	120	100	-	5	-	48	24	19.5	17	45	M55x2	4~M10x25	19.5	58
CBD-42A5	132	132	100	105	-	104.8	82.56	-	-	48	39	34.5	17	45	M55x2	4~M10x30	16	68
CBD-42A6	160	132	100	105	-	133.4	106.38	-	35	48	39	34.5	17	45	M55x2	4~M12x35	18	68
CBD-65	157	157	122	114	140	104.8	-	6	-	54	35	30.5	17.5	68	M75x2	4~M10x30	18	72
CBD-6517	180	157	122	112	170	133.4	-	6	24	54	33	28.5	17.5	68	M75x2	4~M12x30	18	70
CBD-65A5	157	157	122	112	-	104.8	82.56	-	-	54	39	34.5	17.5	68	M75x2	4~M10x25	16	70
CBD-65A6	157	157	122	110	-	133.4	106.38	-	-	54	37	32.5	17.5	68	M75x2	4~M12x35	18.5	68
CBD-65A8	202	157	122	114	-	171.4	139.72	-	38	54	41	36.5	17.5	68	M75x2	4~M16x35	24	72





Application/customer benefits

- Rubber grip style for Push and Draw type collet chucks
- Large gripping area for high rigidity and gripping force while preventing damage to the workpiece
- More accurate than “standard” collets reaching +/- 10um
- Gripping range of +/- 0.5µm
- Quick / easy change
- Dust and swarf proof design

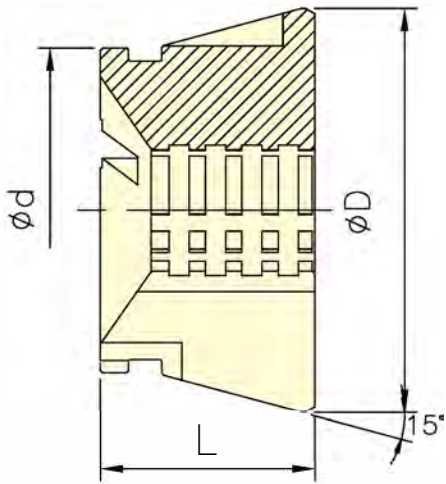

RG-RT

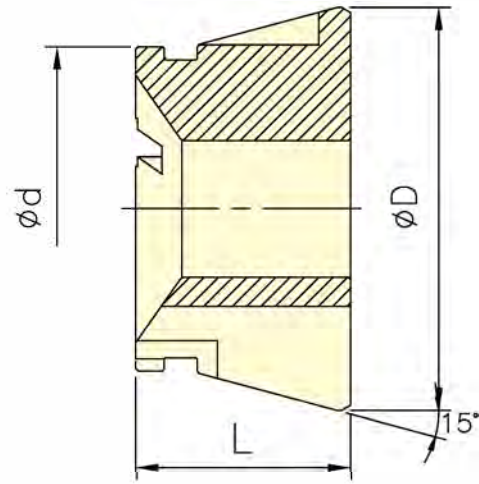

RG-R

Specifications

Model	Max. Chucking Capacity (mm) Round	d	D	L	Matching Collect Chuck
RG-42R	5~42	54	79.5	42.15	CB-42,CBD-42,CBE-42
RG-42RT	5~42	54	79.5	42.15	CB-42,CBD-42,CBE-42
RG-52R	5~50	66	79.5	46.15	CB-52,CBD-52,CBE-52
RG-52RT	5~50	66	79.5	46.15	CB-52,CBD-52,CBE-52
RG-65R	5~65	80	99.7	53.15	CB-65,CBD-65,CBE-65
RG-65RT	5~65	80	99.7	53.15	CB-65,CBD-65,CBE-65

Square and hex collets are made to order.

Dimensions

Test Bar D(S,H)	L mm	A DIN	
		Class1	Class2
3.0~6.0	16	0.015	0.02
6.0~10	25	0.015	0.02
10.0~18.0	40	0.02	0.03
18.0~24.0	50	0.02	0.03
24.0~30.0	60	0.02	0.03
30.0~50.0	80	0.03	0.04
50.0~60.0	100	0.03	0.04

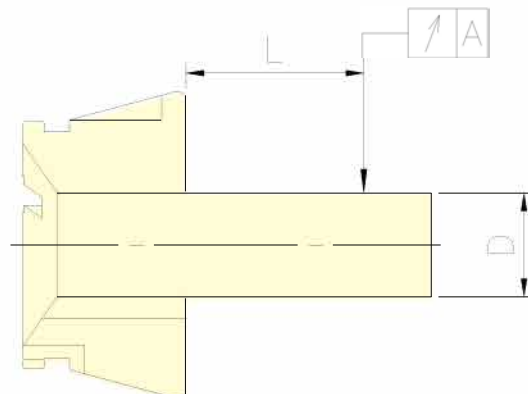

Note01 : Collets chuck are conformed to DIN6343 Class2.

Note02 : AUTOGRIP's rubber grip collets are conformed to DIN6343 Class1.



### Application/customer benefits

- 2 & 3-Jaw Stationary chucks with thru-hole
- For drilling, milling and other applications
- VH-200 and VH-300 match the specifications of the 2H and 3H models

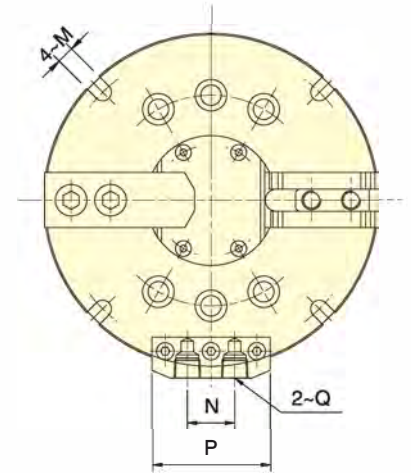
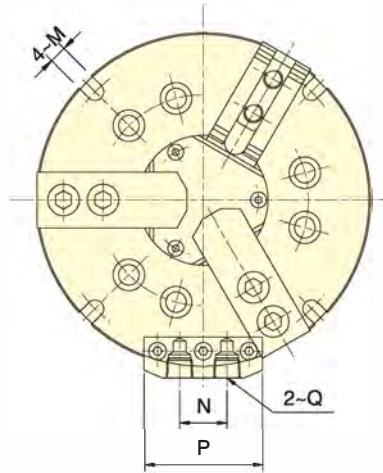
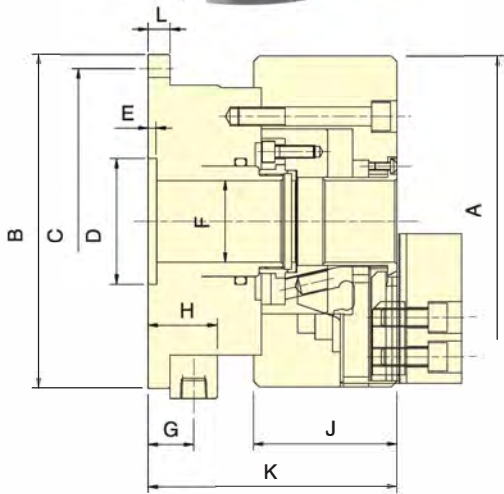

### Specifications

Model	Eff. Piston area cm <sup>2</sup>		Jaw stroke (Dia.) (mm)	Max. pressure MPa(kgf/cm <sup>2</sup> )	Weight (kg)
	Extend	Retract			
VH-204	49.7	46.5	5.4	2.0(20)	7.9
VH-304	49.7	46.5	5.4	3.0(30)	8.1
VH-205	66	58.9	5.4	2.0(20)	11.7
VH-305	66	58.9	5.4	3.0(30)	11.9
VH-206	103.1	94.4	5.5	1.6(16)	19.8
VH-306	103.1	94.4	5.5	2.3(23)	20.2
VH-208	125.7	115.4	7.4	2.0(20)	32.3
VH-308	125.7	115.4	7.4	3.0(30)	33.6
VH-210	202.6	189.3	8.8	1.5(15)	55.5
VH-310	202.6	189.3	8.8	2.3(23)	56.5

### Dimensions

Model	A	B	C	D(H8)	E	F	G	H	J	K	L	M	N	P	Q
VH-204	110	150	132	50	5	23	23	34	59	106.5	12	9	26	62	RC1/4
VH-304	110	150	132	50	5	23	23	34	59	106.5	12	9	26	62	RC1/4
VH-205	135	168	150	60	5	30	23	34	60	111	12	9	26	62	RC1/4
VH-305	135	168	150	60	5	30	23	34	60	111	12	9	26	62	RC1/4
VH-206	169	194	176	80	5	40	25	36	81	141	14	11	26	62	RC1/4
VH-306	169	194	176	80	5	40	25	36	81	141	14	11	26	62	RC1/4
VH-208	210	212	190	80	5	45	29	44	91	158	14	13.5	30	75	RC3/8
VH-308	210	212	190	80	5	45	29	44	91	158	14	13.5	30	75	RC3/8
VH-210	254	266	246	90	6	70	32	47	100	190	17	13	30	75	RC3/8
VH-310	254	266	246	90	6	70	32	47	100	190	17	13	30	75	RC3/8



Application/customer benefits

- 2 & 3-Jaw Stationary chucks with closed center
- For drilling, milling and other applications
- VP-200 and VP-300 match the specifications of the 2P and 3P models

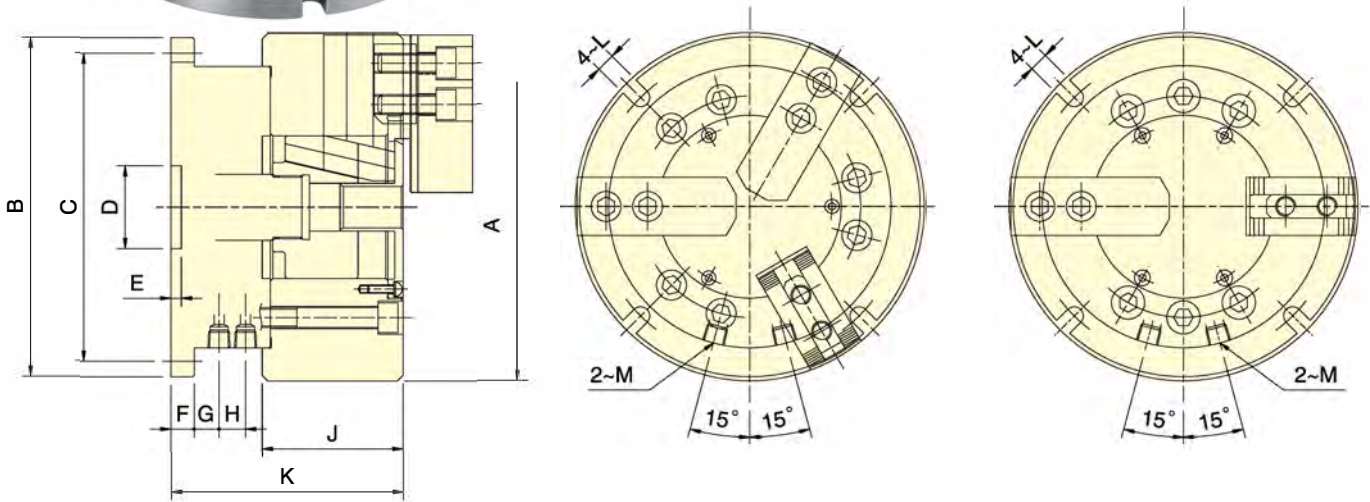

Specifications

Model	Eff. Piston area cm <sup>2</sup>		Jaw stroke (Dia.) (mm)	Max. pressure MPa(kgf/cm <sup>2</sup> )	Weight (kg)
	Extend	Retract			
VP-204	28	24.9	6.4	2.1(21)	7.1
VP-304	28	24.9	6.4	3.2(32)	7.4
VP-205	28	24.9	6.4	2.2(22)	10.2
VP-305	28	24.9	6.4	3.3(33)	10.6
VP-206	63.1	53.5	8.5	2.3(23)	18.3
VP-306	63.1	53.5	8.5	3.4(34)	19.8
VP-208	103.4	90.8	8.8	1.9(19)	31.6
VP-308	103.4	90.8	8.8	2.8(28)	33.6
VP-210	153.1	133.5	8.8	1.5(15)	52.8
VP-310	153.1	133.5	8.8	2.2(22)	54.5

Dimensions

Model	A	B	C	D(H8)	E	F	G	H	J	K	L	M
VP-204	110	146	130	30	4.5	12	18	2	52	92	9	RC1/4
VP-304	110	146	130	30	4.5	12	18	2	52	92	9	RC1/4
VP-205	135	146	130	30	4.5	12	18	2	55	95	9	RC1/4
VP-305	135	146	130	30	4.5	12	18	2	55	95	9	RC1/4
VP-206	165	178	160	40	5	12	14.5	12.5	74	125	11	RC1/4
VP-306	165	178	160	40	5	12	14.5	12.5	74	125	11	RC1/4
VP-208	210	205	186	40	5	14	15	16	85	140	11	RC1/4
VP-308	210	205	186	40	5	14	15	16	85	140	11	RC1/4
VP-210	254	248	225	50	6	17	20	18	89	176	13	RC3/8
VP-310	254	248	225	50	6	17	20	18	89	176	13	RC3/8





Application/customer benefits

- 3-Jaw
- Closed Center
- Built-in hydraulic cylinder
- Easy installation
- Optional "lock valve" kit for pneumatic operation is available. Lock valve maintains pressure when air supply is shut off.
- This and compact design and uses standard soft and hard jaws.
- Can be installed on Autogrip MP4 base plate

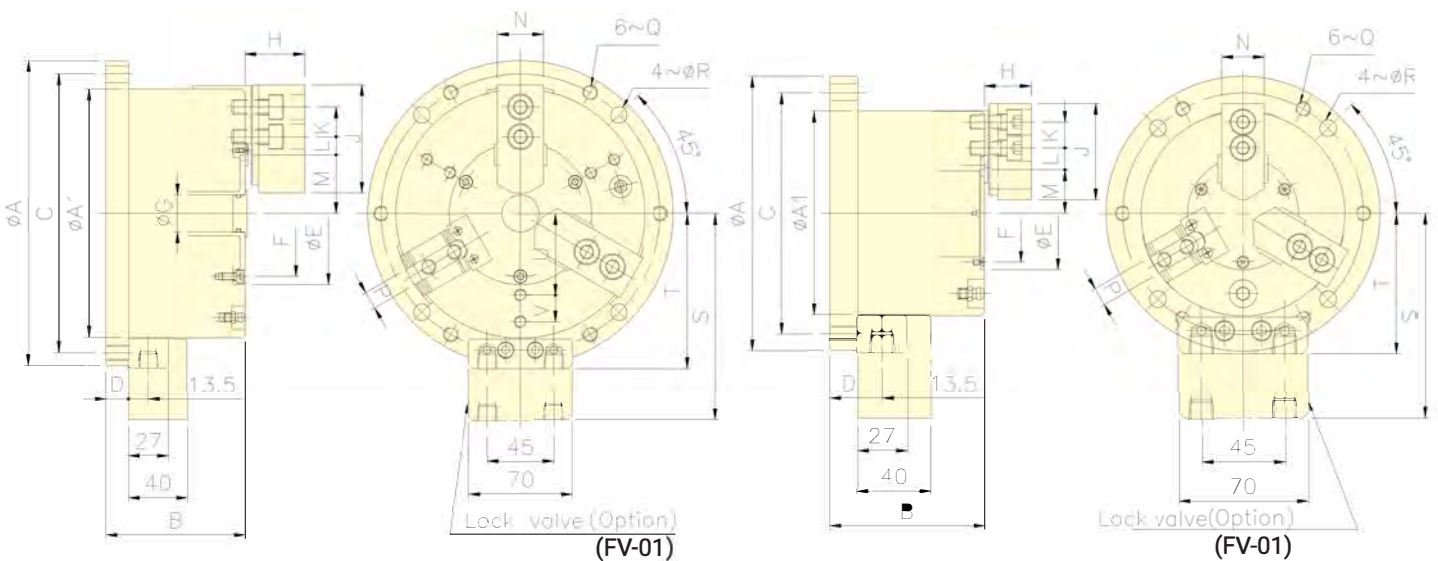

SP-306,308,310

SP-304

Specifications

Model	Jaw stroke (Dia.) (mm)	Chucking Dia. (mm)		Max. clamping force kN		Max. pressure kg/cm <sup>2</sup>		Min. pressure (kg/cm <sup>2</sup> )	Air consumption lit (at 6.0 kgf/cm <sup>2</sup> )	Weight (kg)
		Max.	Min.	Pneumatic (at 6.0kgf/cm <sup>2</sup> )	Hydraulic (at 13.0kgf/cm <sup>2</sup> )	Pneumatic	Hydraulic			
SP-304	5.1	110	10	7.5	22	6	13	2	0.5	7
SP-306	5.5	168	30	21	52	6	13	2	1.4	16.5
SP-308	6.8	210	42	33	74	6	13	2	2.5	28.7
SP-310	7	254	52	48	107	6	13	2	4.2	42

Dimensions

Model	A(h7)	A1	B	C	D	E(H7/h7)	F	G	H	J	K	Lmax.	Lmin.	Mmax.	Mmin.	N	P	Q	R	S	T	U	V
SP-304	148	110	84	130	15	60	52	-	25.25	52	14	14.75	11.75	23.5	20.95	23	10	M8X1.25	9	110.5	75.5	-	-
SP-306	206	168	94	188	15	96	85	25	40.25	73	20	18.25	12.25	39.5	36.75	31	12	M10X1.5	11	139.5	104.5	55	18
SP-308	248	210	108	230	15	113	102	32	41.25	95	25	20.75	16.25	49.5	46.1	35	14	M10X1.5	11	160.5	125.5	68	25
SP-310	300	254	112	280	16	138	127	54	46.25	110	30	29.25	20.25	57	53.5	40	16	M12X1.75	13	182.5	147.5	85	30



Application/customer benefits

- 3-Jaw stationary chuck with pull back feature with closed center
- Provides radial clamping and axial pull-down simultaneously moving workpiece closer to the surface of the chuck
- Works with airtight detection and axial positioning systems.
- Heat treatment/hardening of the chuck body, precision boring and precision machining of all chuck parts guarantee accuracy, high clamping force and long life and make this chuck suitable for heavy duty machining applications
- Can be installed on Autogrip MP4 base plate

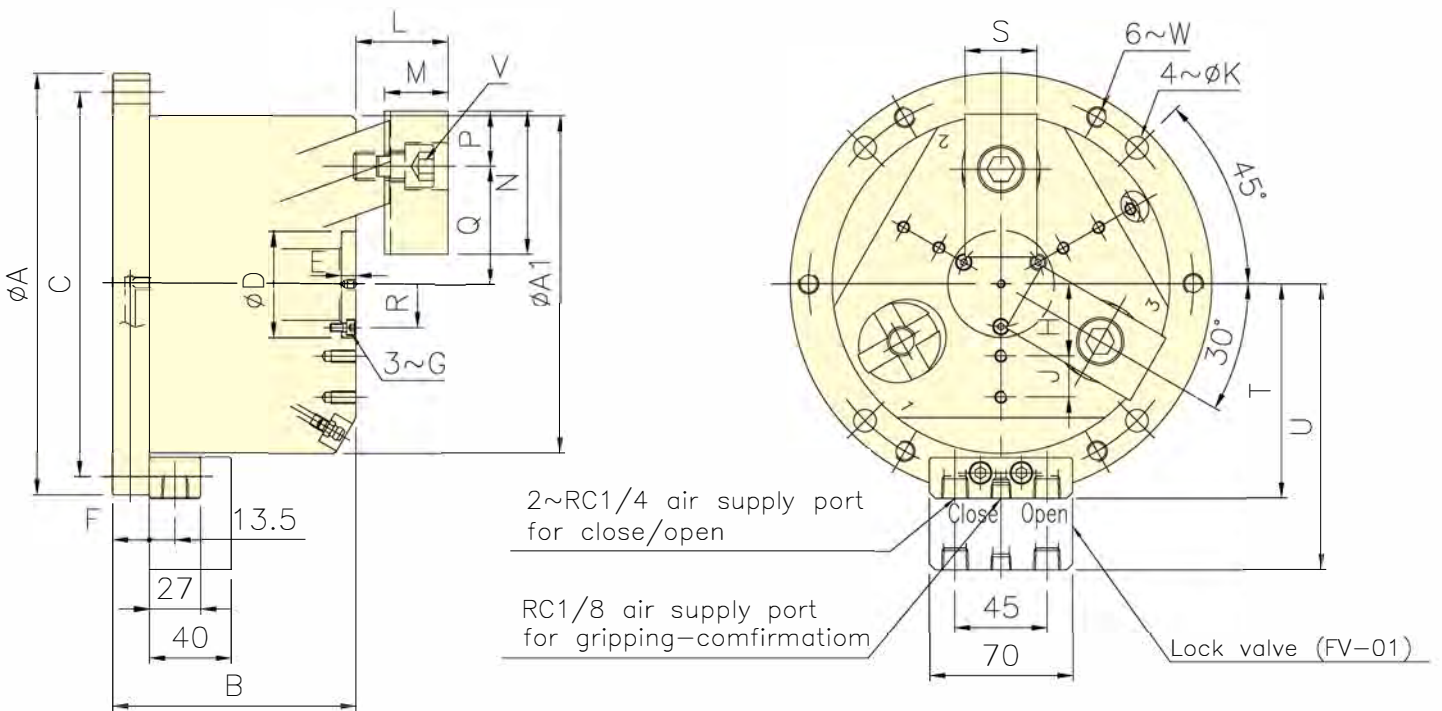

Specifications

Model	Jaw stroke (Dia.) (mm)	Chucking Dia. (mm)		Max. clamping force kN		Max. pressure kg/cm <sup>2</sup>		Min. pressure (kg/cm <sup>2</sup> )	Air consumption lit (at 6.0 kgf/cm <sup>2</sup> )	Weight (kg)
		Max.	Min.	Pneumatic (at 6.0kgf/cm <sup>2</sup> )	Hydraulic (at 13.0kgf/cm <sup>2</sup> )	Pneumatic	Hydraulic			
*SD-304	5	110	18	5	10.9	6	13	2	0.26	8.1
*SD-306	7.2	165	35	11.5	25	6	13	2	0.58	20.6
*SD-308	7.2	210	28	21.7	47	6	13	2	1.02	34.1

Dimensions

Model	A(h7)	A1	B	C	D(H7/h7)	E	F	G	H	J	K	L max.	L min.	M	N	P	Q max.	Q min.	R	S	T	U	V	W
*SD-304	148	110	93.5	130	35	2	15	M3	22.5	10	9	30	23	19.5	52	19	37	34.5	27	25	75.5	110.5	3~M10	M8x1.25
*SD-306	206	165	116	188	52	7	18	M4	35	20	11	45	35	31	70	27	57.8	54.2	42	35	104.5	139.5	3~M14	M10x1.5
*SD-308	248	210	122	230	65	10	18	M5	45	25	11	56	46	41	84	31	70.8	67.2	53	40	125.5	160.5	6~M12	M10x1.5

\*model produced only by order.

STATIONARY CHUCK



Application/customer benefits

- 3-Jaw stationary chuck with pull back feature with closed center
- Provides radial clamping and axial pull-down simultaneously moving workpiece closer to the surface of the chuck
- Works with airtight detection and axial positioning systems.
- Heat treatment/hardening of the chuck body, precision boring and precision machining of all chuck parts guarantee accuracy, high clamping force and long life and make this chuck suitable for heavy duty machining applications
- Can be installed on Autogrip MP4 base plate

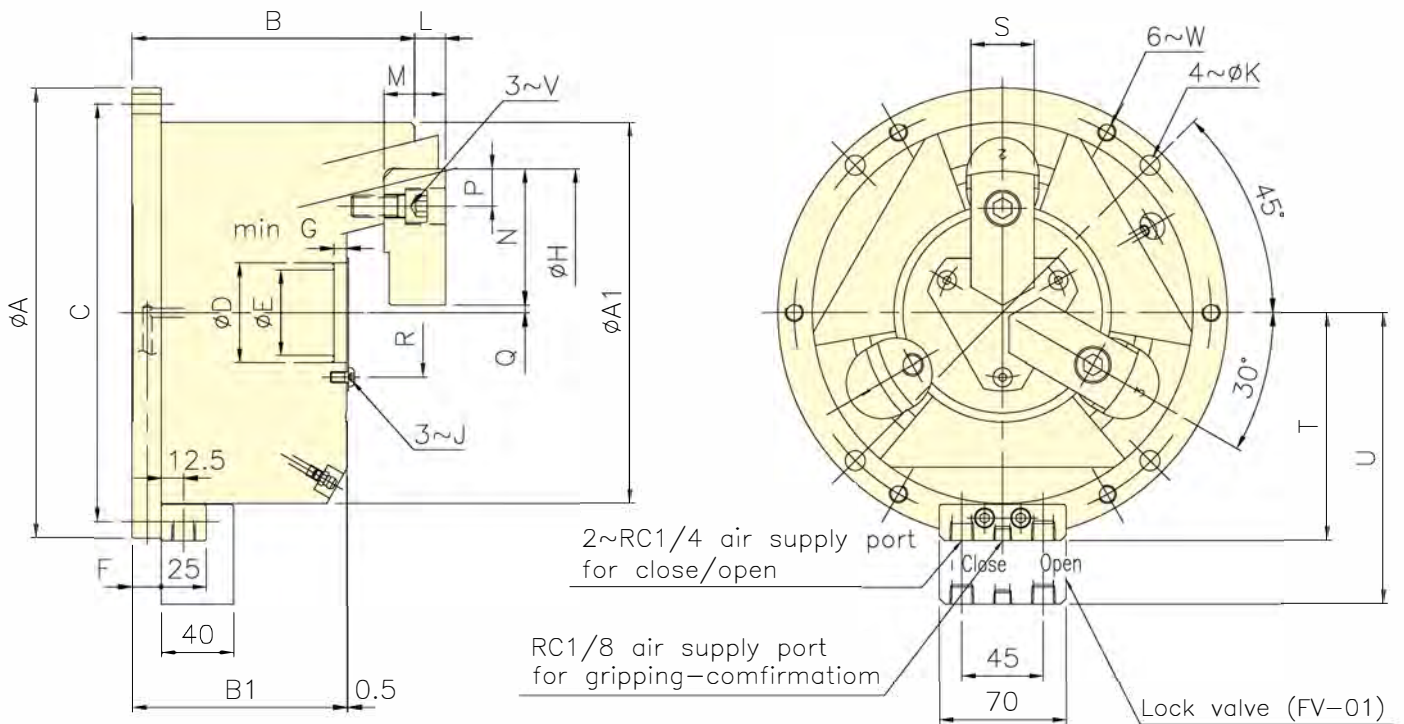

Specifications

Model	Jaw stroke (Dia.) (mm)	Chucking Dia. (mm)		Max. clamping force kN		Max. pressure kg/cm <sup>2</sup>		Min. pressure (kg/cm <sup>2</sup> )	Air consumption lit (at 6.0 kgf/cm <sup>2</sup> )	Weight (kg)
		Max.	Min.	Pneumatic (at 6.0kgf/cm <sup>2</sup> )	Hydraulic (at 13.0kgf/cm <sup>2</sup> )	Pneumatic	Hydraulic			
* SU-304	3	60	5	6.7	16	6	13	2	0.26	7.4
* SU-306	5	105	31	18.5	40	6	13	2	0.58	18
* SU-308	5	132	32	37	80	6	13	2	1.02	31.5

Dimensions

Model	A(h7)	A1	B	B1	C	D(H6)	E	F	G	H(H6)	J	K	L max.	L min.	M	N	P	Q max.	Q min.	R	S	T	U	V	W
* SU-304	148	110	101.5	83.5	130	32	24	15	4.5	84	M5	9	7	1	17	40	9.5	2.75	1.25	42	20	75.5	110.5	M6	M8x1.25
* SU-306	206	168	136.5	104	188	35	25	18	6	129	M5	11	15	5	30	50	17	15.75	13.25	49	30	104.5	139.5	M10	M10x1.5
* SU-308	248	210	155	118	230	55	45	18	7	156	M6	11	17	7	34	63	20.5	16.25	13.75	71	35	125.5	160.5	M12	M10x1.5

\*model produced only by order.

STATIONARY CHUCK





**Application/customer benefits**

- 3-Jaw Pull Lock style for ID gripping with closed center
- Pull back function / Pressure Detection for parallelism
- High precision and stability for many ID gripping applications, including finishing
- Stationary cylinder not required
- Can be installed on Autogrip MP4 base plate

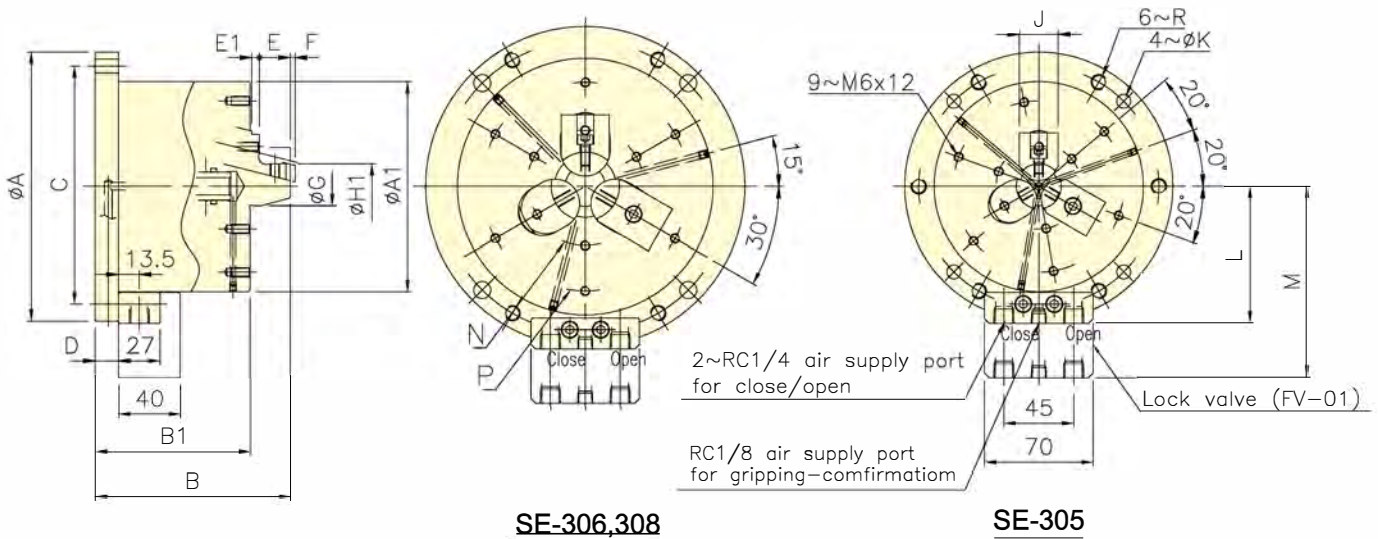

**SE-306,308**

**SE-305**

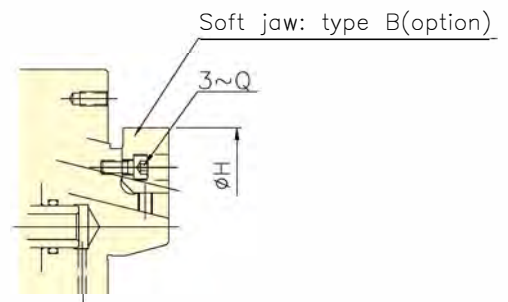
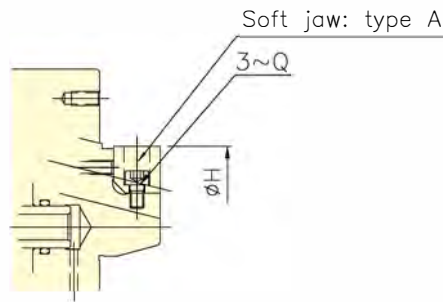

**Specifications**

Model	Jaw stroke (Dia.) (mm)	Chucking Dia. (mm)		Max. clamping force kN		Max. pressure kg/cm <sup>2</sup>		Min. pressure (kg/cm <sup>2</sup> )	Air consumption lit (at 6.0 kgf/cm <sup>2</sup> )	Weight (kg)
		Max.	Min.	Pneumatic (at 6.0kgf/cm <sup>2</sup> )	Hydraulic (at 13.0kgf/cm <sup>2</sup> )	Pneumatic	Hydraulic			
*SE-305	3	83	29	14.3	41	7	13	2	0.46	14.6
*SE-306	5	110	44	20	57	7	13	2	0.58	20
*SE-308	5	150	50	32	78	7	13	2	1.02	33

**Dimensions**

Model	A(h7)	A1	B	B1	C	D	E	E1	Fmax	Fmin	G	Type A		Type B		H1		J	K	L	M	N	P	Q	R	
												Hmax	Hmin	Hmax	Hmin	Hmax	Hmin									
*SE-305	173	135	126	100	155	15	20	5	3	-3	25	68	50	83	67	50	29	25	9	88	123	55	110	134	3~M6	M8x1.25
*SE-306	206	168	140	108	188	18	23	7	5	-5	40	90	70	110	89	70	44	31	11	104.5	139.5	76	134	3~M8	M10x1.5	
*SE-308	248	210	164	119	230	18	30	9	5	-5	49	110	90	150	108	90	50	35	11	125.5	160.5	100	170	3~M8	M10x1.5	

\*model produced only by order.



### Application/customer benefits

- For milling machines / machining centers
- Allows simultaneous use of up to 4 chucks (can be customized to accept 6 chucks)
- Works with Autogrip chuck models SP, SD, SU, SE
- Hydraulic or Pneumatic
- Individual connection for each chuck
- Special design that reduces the height of the work surface
- Lock Valve & Air Detection system are optional

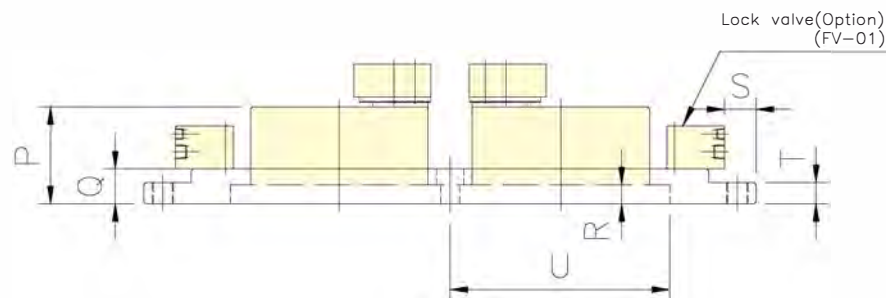
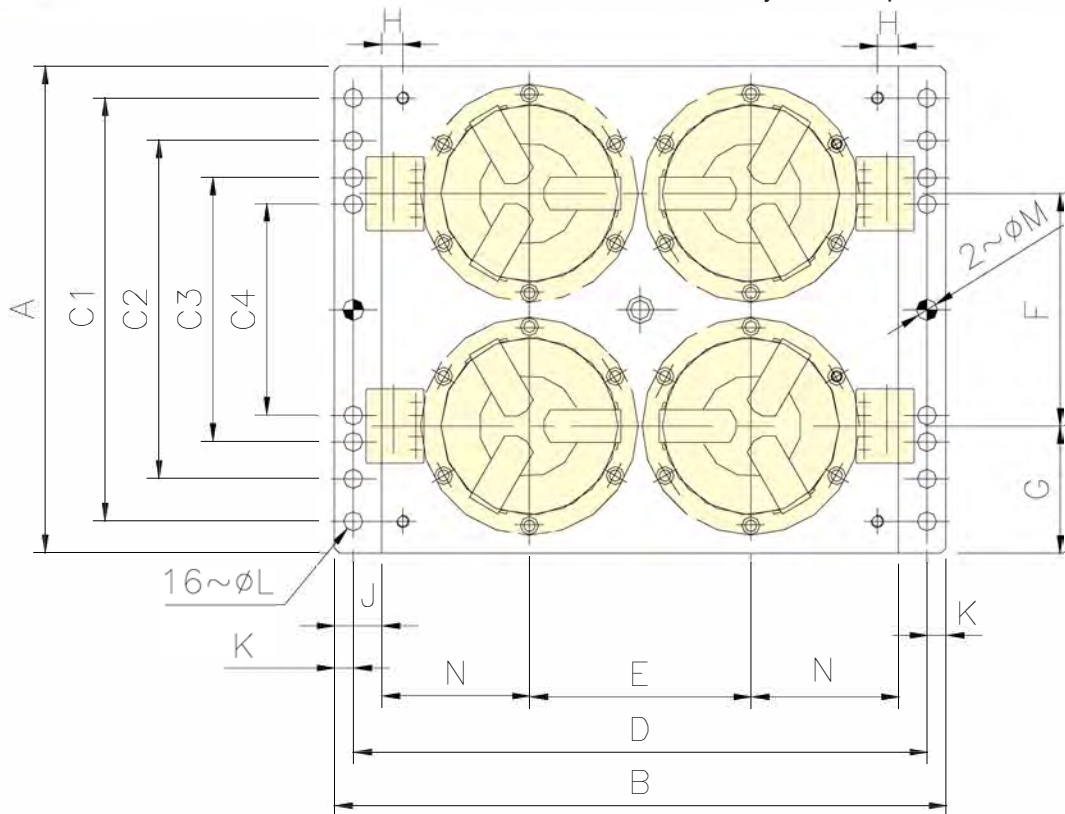

### Dimensions

Model	A	B	C1	C2	C3	C4	D	E	F	G	H	J	K	L	M	N	P	Q	R	S	T	U
MP4-06206	460	580	400	320	250	200	544	210	220	120	20	45	18	17	20	140	*B	33	18	20	20	206

\*B compare the size B for assembled chuck model.



### Application/customer benefits

- 2~Jaw Lever style synchronous clamp with long jaw stroke
- All mated surfaces and parts are hardened, precision ground and lubricated
- High rigidity and clamping accuracy

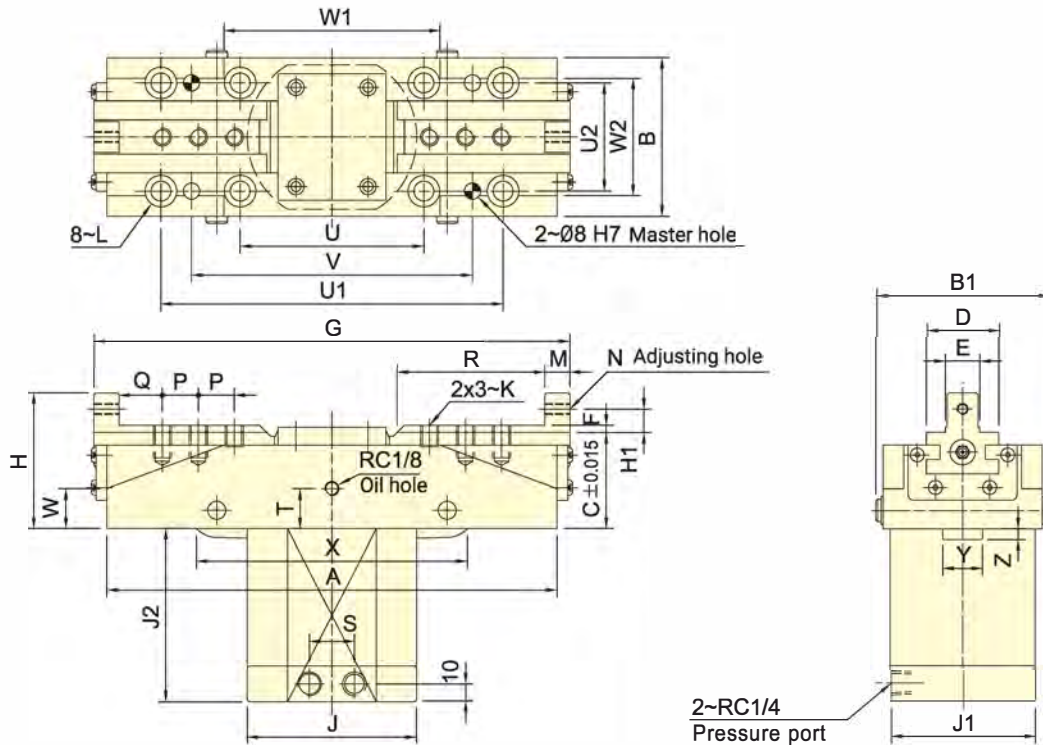

SYNCHRONOUS CLAMPS

### Specifications

Model	Eff. Pistor area cm <sup>2</sup>		Jaw stroke (Dia.) (mm)	Clamping capacity (mm)	Max. clamping force kN (kgf)	Max. pressure MPa(kgf/cm <sup>2</sup> )	Weight (kg)
	Extend	Retract					
CP-20	28.27	25.13	20	150	16.2(1650)	3.5(35)	9.5
CP-30A	28.27	25.13	30	180	17.7(1800)	3.5(35)	11
CP-30	28.27	25.13	30	210	17.7(1800)	3.5(35)	12
* CP-40	28.27	25.13	40	200	14.7(1500)	3.5(35)	12
CP-50	38.48	33.57	50	215	20.3(2070)	3.5(35)	18.5
* CP-70	50.26	45.35	70	235	26.9(2742)	3.5(35)	30

### Dimensions

Model	A	B	B1	C	D	E(h6)	F	Gmax	Gmin	H	H1	J	J1	J2	K	L	M	N	P	Q	R	S	T	U	U1	U2	V	W	W1	W2	X	Y	Z
CP-20	215	88	96	53	40	18	4	249	229	75	13	94	76	83.5	M10x1.5	M10	12	M6x1	18	20	66	24	22	102	190	60	156	32	110	65	150	22	4
CP-30A	250	88	96	53	40	18	4	295	265	75	13	94	76	96	M10x1.5	M10	14	M6x1	20	24	96	24	22	102	190	60	156	20	120	65	156	22	6
CP-30	280	88	96	53	40	22	4	327	297	75	13	94	76	96	M12x1.75	M10	14	M6x1	20	24	98	24	22	102	190	60	156	23	110	65	156	22	6
* CP-40	270	88	96	53	40	22	4	331	291	75	13	94	76	110	M12x1.75	M10	14	M6x1	20	24	98	24	22	102	190	60	156	25	110	65	150	22	10.5
CP-50	300	110	115	65	50	28	5	369	319	90	15	105	105	120	M12x1.75	M10	16	M8x1.25	21	28	102	30	32	105	230	85	195	29	140	80	180	30	10
*CP-70	346	120	126	89	55	32	5	430	360	114	15	115	115	146	M14x2	M12	16	M8x1.25	23	28	112	30	52	120	275	79	240	42	155	90	210	34	23.5

\*model produced only by order.





Application/customer benefits

- Feed mechanism is transmitted by Rack & Pinion or Wedge Plunger systems
- Steady speed feeds and easy speed and stroke adjustments
- All mated surfaces and parts are hardened, precision ground and lubricated
- High rigidity and clamping accuracy
- Stopper accuracy +/- 0.03µm
- Works with Autogrip RS style cylinder
- Wedge Plunger type facing heads can be used with electro servo and ball screw mechanisms

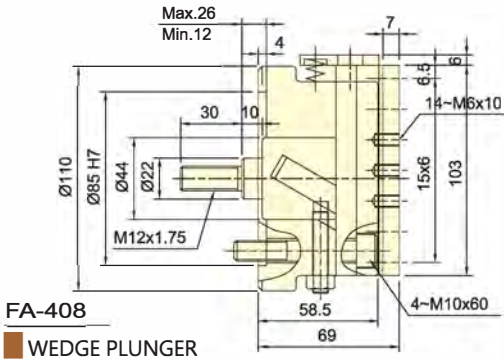

FA-408  
WEDGE PLUNGER

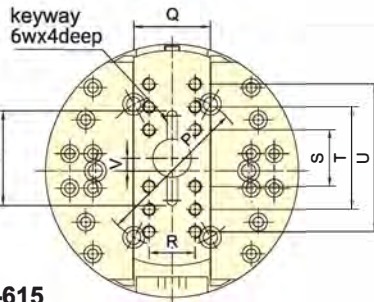
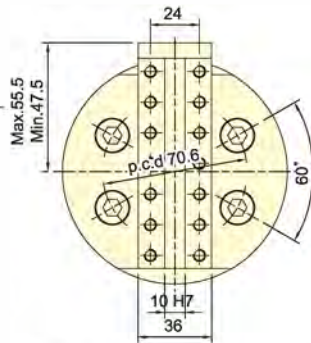

FA-615  
FA-830  
FA-1570 RACK AND PINION

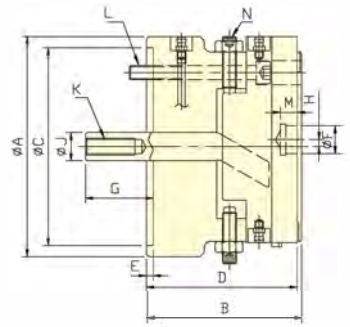

FA-610  
FA-812 WEDGE PLUNGER

FACING HEADS

Specifications

Model	Plunger stroke (Dia.) (mm)	Slider stroke (Dia.) (mm)	Max. speed min <sup>-1</sup> (r.p.m.)	Max. feed speed mm/min.	Weight (kg)	Matching cylinder	Max. pressure MPa(kgf/cm <sup>2</sup> )
FA-408	14	8	1600	400	4.2	RS-6520N	1.0(10)
FA-615	15	15	1200	300	11.9	RS-6520N	1.2(12)
FA-830	30	30	800	240	23.9	RS-6530N	1.8(18)
* FA-1570	70	70	500	120	167	RS-1080N	2.6(26)

Model	Plunger stroke (Dia.) (mm)	Slider stroke (Dia.) (mm)	Max. speed min <sup>-1</sup> (r.p.m.)	MAX D.B. PULL kgf	I kg·m <sup>2</sup>	Weight (kg)	Matching cylinder
* FA-610	18	10	1200	280	0.04	14.5	RS-6520N
* FA-812	21	12	800	450	0.14	28.5	RS-6520N

Dimensions

Model	A	B	C(H7)	D	E	F(H7)	G max.	G min.	H	J	K	L	M	N	P	Q	R	S	T	U	V	W
FA-615	150	107	110	102	5	25	40	25	35	20	M12x1.75	3-M10x40	12	8-M8x16	82.6	50	32	32	68	-	±7.5	56
FA-830	198	126	140	121	6	30	54	24	45	25	M16x2	6-M10x55	15	12-M10x20	120	60	36	40	80	120	±15	66
* FA-1570	400	200	300	192	6	60	110	40	75	50	M30x3.5	6-M20x90	15	8-M16x20	235	120	80	130	260	-	±17.5	-

Model	A	B	C(H7)	D	E	F(H7)	G max.	G min.	H	J	K	L	M	N	P	Q	R(H8)	S	T	U
* FA-610	156	110	140	107	5	20	66	48	±5	20	M12x1.75	4-M10x90	12	2-M10x45	104.8	28	8	4-M10x16	40	40
* FA-812	198	130	170	127	5	25	84	63	±6	25	M16x2.0	4-M12x105	12	2-M12x60	133.4	32	10	4-M10x16	50	50

\*model produced only by order.

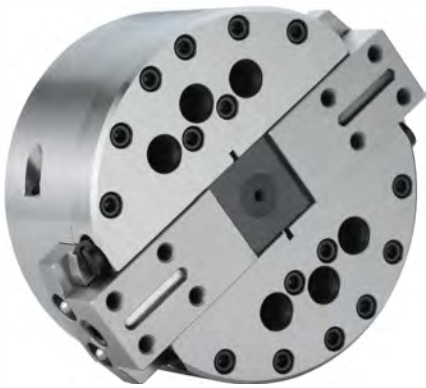

Application/customer benefits

- Feed mechanism is transmitted by Lever or Helical Gear Rack systems for precision work
- Steady speed feeds and easy speed and stroke adjustments
- All mated surfaces and parts are hardened, precision ground and lubricated
- High rigidity and clamping accuracy
- Stopper accuracy +/- 0.03µm
- Works with Autogrip RS style cylinder
- Wedge Plunger type facing heads can be used with electro servo and ball screw mechanisms

FD-632  
FD-840  
FD-1060

CRANK TYPE

FD-880 HELICAL GEAR RACK TYPE

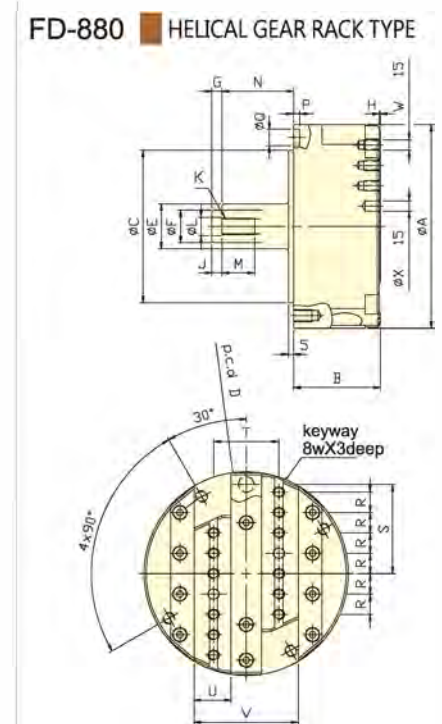
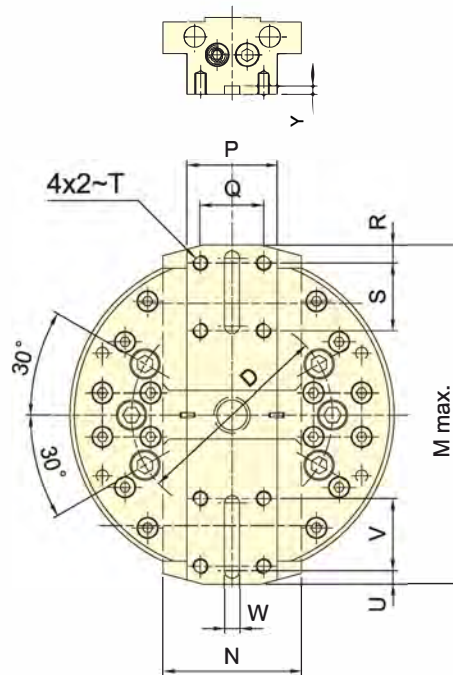
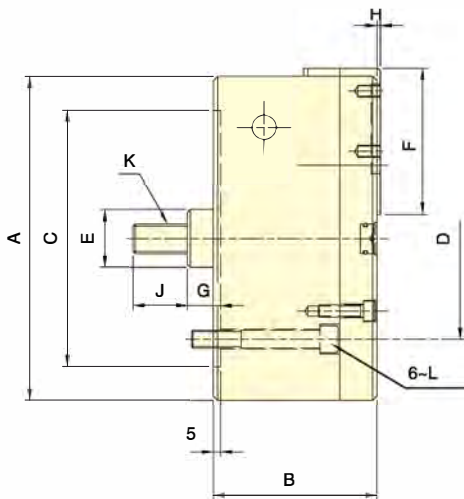

FACING HEADS

Specifications

Model	Plunger stroke (Dia.) (mm)	Slider stroke (Dia.) (mm)	Max. speed min <sup>-1</sup> (r.p.m.)	Max. feed speed mm/min.	Weight (kg)	Matching cylinder	Max. pressure MPa (kgf/cm <sup>2</sup> )
FD-632	20	32	3200	300	13.6	RS-1030N	2.4(24)
FD-840	25	40	2500	240	30	RS-1030N	3.0(30)
FD-1060	35	60	1800	200	41.5	RS-1040N	3.0(30)

Model	Plunger stroke (Dia.) (mm)	Slider stroke (Dia.) (mm)	Max. speed min <sup>-1</sup> (r.p.m.)	Max. D.B. PULL kgf	Weight (kg)	Matching cylinder	l kg·m <sup>2</sup>
* FD-880	48	80	2500	1050	17	RS-1030N	0.081

Dimensions

Model	A	B	C(H7)	D	E	F	G max.	G min.	H	J	K	L	M	N	P	Q	R	S	T	U	V	W(H8)	Y
FD-632	168	93	140	104.8	32	76	31	11	2	36	M16x2.0	6~M10x75	188	70	40	25	10	32	M8x15	10	32	6	4
FD-840	215	109	170	133.4	38	96.5	32.5	7.5	2	36	M20x2.5	6~M12x85	238	90	60	42	12	45	M10x15	12	45	10	6
FD-1060	254	123	220	171.4	38	110.5	32.5	-2.5	4	36	M20x2.5	6~M16x125	286	90	65	46	15	50	M10x15	12	50	10	6

Model	A	B	C(H6)	D	E	F	G max.	G min.	H	J	K	L(H7)	M	N	P	Q	R	S	T	U	V	W	X(H7)
* FD-880	200	85	150	175	44	32	58	10	1	10	M16x1.5	18	32	70	6	16.2	20	87.5	64	36	102	12~M10	10

\*model produced only by order.



### Application/customer benefits

- Super short form hydraulic cylinder (33% shorter than standard cylinders) with thru-hole
- Lightweight with large thru-hole
- Built-in safety check and pressure relief valves
- Can be mounted from the rear of the cylinder

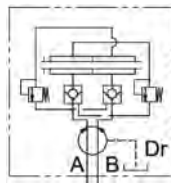
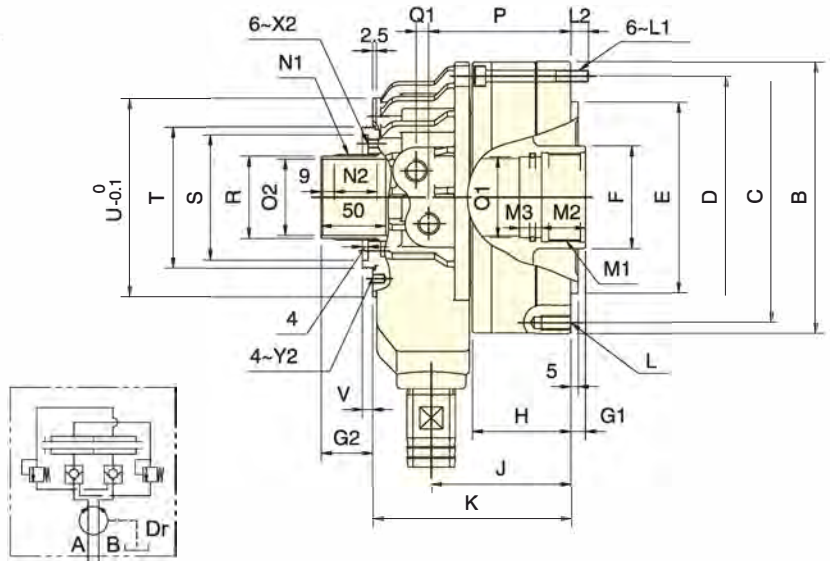
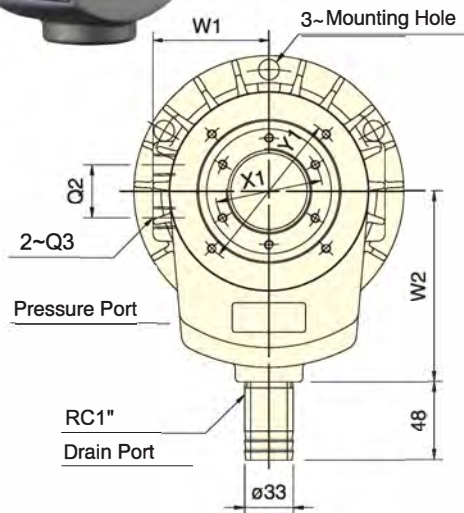

### Specifications

Model	Eff. piston area cm <sup>2</sup>		Piston stroke (Dia.) (mm)	Max. speed min <sup>-1</sup> (r.p.m.)	Max. pressure MPa(kgf/cm <sup>2</sup> )	I kg·m <sup>2</sup> Moment of inertia	Weight (kg)	Total oil leakage lit./min.
	Extend	Retract						
TK-A528	73	69.7	12	8000	4.5 (45)	0.012	6.2	3
TK-A533	73	69.7	12	8000	4.5 (45)	0.012	6	3
TK-C643	99.1	88.0	15	7000	4.5 (45)	0.018	7.5	3
TK-A646	105.0	93.9	15	7000	4.5 (45)	0.018	7.3	3
TK-B646	105.0	93.9	15	7000	4.5 (45)	0.018	8.6	3
TK-C646	99.1	88.0	15	7000	4.5 (45)	0.018	7.5	3
TK-646A	105	93.9	15	7000	4.5 (45)	0.019	9.2	3
TK-B846	135.3	125.0	20	6300	4.5 (45)	0.032	12.4	3.9
TK-A853	135.3	125.0	20	6300	4.5 (45)	0.032	11.8	3.9
TK-B853	135.3	125.0	20	6300	4.5(45)	0.032	11.6	3.9
TK-1068	165.9	149.9	25	5500	4.5 (45)	0.065	17.8	4.2
TK-1075	165.9	149.9	25	5500	4.5 (45)	0.065	16.8	4.2
TK-1078	165.9	149.9	25	5500	4.5 (45)	0.065	16.5	4.2

### Dimensions

Model	A	B	C	D	E	F	G1max	G1min	G2max	G2min	H	J	K	L	L1	L2	M1	M2	M3	N1	N2	N3	O1	O2	P	Q1	Q2	Q3	R	S	T	U	V	W1	W2	X1	X2	Y1	Y2
TK-A528	105	141	125	125	110	45	12	0	32	20	49	77.5	123	6~M8x20	M8x55	14	M38x1.5	25	13	M39x1.5	25	8	35	28	79	8.5	30	RC1/4	37	62	70	98	6	62	110	49	M6x6	83	M5x6
TK-A533	105	141	125	125	110	45	12	0	32	20	49	77.5	123	6~M8x20	M8x55	14	M38x1.5	25	13	M39x1.5	25	8	35	33	79	8.5	30	RC1/4	37	62	70	98	6	62	110	49	M6x6	83	M5x6
TK-C643	128	156	140	140	120	65	15	0	44	29	56	85	125	12~M10x20	M8x60	12	M50x2	25	13	M52x1.5	29	9	45	43	87	8.5	36	RC3/8	50	76	85	116	6	74	120	64	M6x6	98	M5x6
TK-A646	128	162	147	147	130	65	15	0	44	29	56	85	125	12~M10x20	M8x60	12	M55x2	25	13	M52x1.5	29	9	50	46	87	8.5	36	RC3/8	50	76	85	116	6	74	120	64	M6x6	98	M5x6
TK-B646	128	162	130	147	100	65	15	0	44	29	66	95	135	12~M10x20	M8x70	12	M55x2	25	13	M52x1.5	29	9	50	46	97	8.5	36	RC3/8	50	76	85	116	6	74	120	64	M6x6	98	M5x6
TK-C646	125	156	140	140	120	65	15	0	44	29	56	85	125	12~M10x20	M8x60	12	M55x2	25	13	M52x1.5	29	9	50	46	87	8.5	36	RC3/8	50	76	85	116	6	74	120	64	M6x6	98	M5x6
TK-646A	128	162	147	147	130	65	15	0	40	29	57	85	126	12~M10x20	M8x65	15	M55x2	25	13	M52x1.5	29	9	50	46	88	8.5	36	RC3/8	50	76	85	116	6	74	120	64	M6x6	98	M5x6
TK-B846	145	185	170	165	130	70	20	0	48	28	66	95	135	12~M10x20	M8x70	12	M55x2	30	15	M58x1.5	30	8	50	46	97	8.5	36	RC3/8	56	85	96	128	7	79	130	73	M6x7	110	M6x6
TK-A853	145	185	170	165	140	70	20	0	48	28	66	95	135	12~M10x20	M8x70	12	M60x2	30	15	M58x1.5	30	8	55	53	97	8.5	36	RC3/8	56	85	96	128	7	79	130	73	M6x7	110	M6x6
TK-B853	145	185	170	165	130	70	20	0	48	28	66	95	135	12~M10x20	M8x70	12	M60x2	30	15	M58x1.5	30	8	55	53	97	8.5	36	RC3/8	56	85	96	128	7	79	130	73	M6x7	110	M6x6
TK-1068	170	212	190	190	160	98	25	0	50	25	73	107	157	12~M10x20	M10x80	17	M75x2	35	15	M84x2	33	9	70	68	109	12	40	RC1/2	81	108	121	164	7	98	160	98	M6x8	155	M6x8
TK-1075	170	212	190	190	160	98	25	0	50	25	73	107	157	12~M10x20	M10x80	17	M85x2	35	15	M84x2	33	9	80	75	109	12	40	RC1/2	81	108	121	164	7	98	160	98	M6x8	155	M6x8
TK-1078	170	212	190	190	160	98	25	0	50	25	73	107	157	12~M10x20	M10x80	17	M87x2	35	15	M86x2	33	9	83	78	109	12	40	RC1/2	83	108	121	164	7	98	160	98	M6x8	155	M6x8





### Application/customer benefits

- Super short form hydraulic cylinder (33% shorter than standard cylinders) with thru-hole
- Lightweight with large thru-hole
- Built-in safety check and pressure relief valves
- Can be mounted from the rear of the cylinder

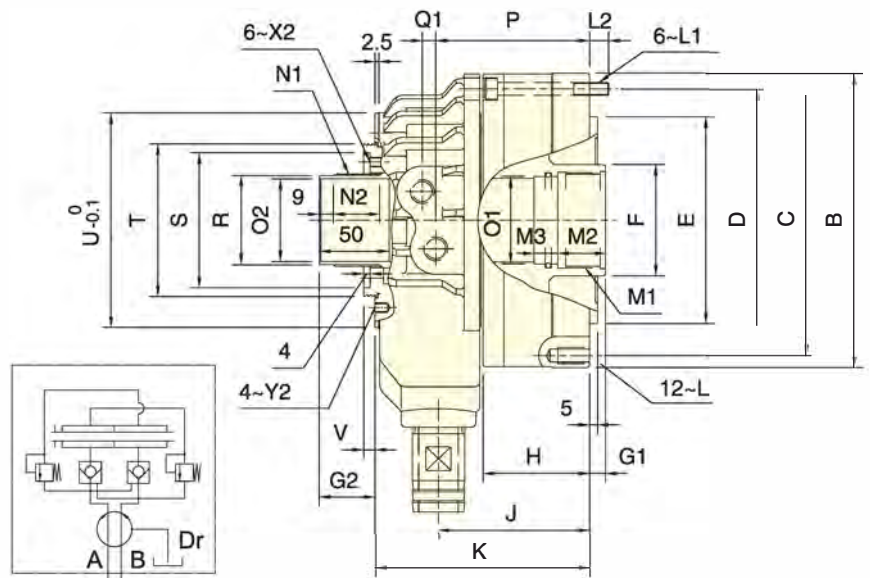
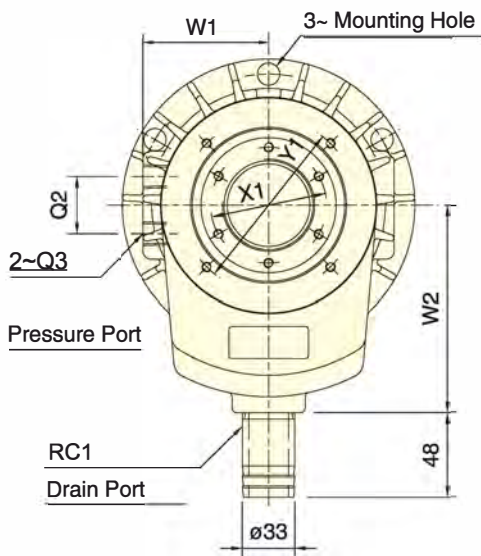

### Specifications

Model	Eff. piston area cm <sup>2</sup>		Piston stroke (Dia.) (mm)	Max. speed min-1(r.p.m.)	Max. pressure MPa(kgf/cm <sup>2</sup> )	I kg-m <sup>2</sup> Moment of inertia	Weight (kg)	Total oil leakage lit./min.
	Extend	Retract						
TK-1287	234	217.5	30	3800	4.0 (40)	0.092	26.5	4.5
TK-A1291	234	217.5	30	3800	4.0 (40)	0.092	24.8	4.5
TK-1511	356.5	335.3	30	3000	3.5 (35)	0.38	53.6	7
TK-1512	356.5	335.3	30	3000	3.5 (35)	0.38	49.5	7
TK-2114	373.2	336.1	35	2500	3.0 (30)	0.54	58.2	8

### Dimensions

Model	A I.D.	B	C	D	E h7	F	G1max	G1min	G2max	G2min	H	J	K	L	L1	L2	M1	M2	M3	N1	N2	O1 H8	O2 H6	P	Q1	Q2	Q3	R g7	S H7	T	U	V	W1	W2	X1	X2	Y1	Y2
TK-1287	200	245	215	225	180	110	30	0	55	25	87	127	185	M12x24	M10x95	18.5	M95x2	35	15	M99x2	38	90	87	128.5	15	45	RC1/2	96	120	138	180	7	110	185	108	M6x10	165	M6x10
TK-A1291	200	245	215	225	180	110	30	0	59	29	86	126	184	M12x24	M10x90	14.5	M100x2	35	15	M99x2	38	95	91	127.5	15	45	RC1/2	96	120	138	180	7	110	185	108	M6x10	165	M6x10
TK-1511	250	305	275	280	230	140	30	0	55	25	100	154	224	M16x32	M12x110	22.5	M120x2	45	15	M129x2	38	115	110	152	17	50	RC1/2	126	150	170	227	7	134	210	138	M6x10	210	M6x10
TK-1512	250	305	275	280	230	140	30	0	55	25	100	154	224	M16x32	M12x110	22.5	M130x2	45	15	M129x2	38	125	120	152	17	50	RC1/2	126	150	170	227	7	134	210	138	M6x10	210	M6x10
TK-2114	265	320	295	295	240	165	35	0	60	25	115	173.5	247.5	M16x32	M12x120	17.5	M155x2	45	20	M149x2	38	145	140	170	17	50	RC1/2	146	170	190	250	7	145	210	160	M6x10	230	M6x10



### Application/customer benefits

- New design, short form hydraulic cylinder with thru-hole
- Lightweight
- Built-in safety check and pressure relief valves

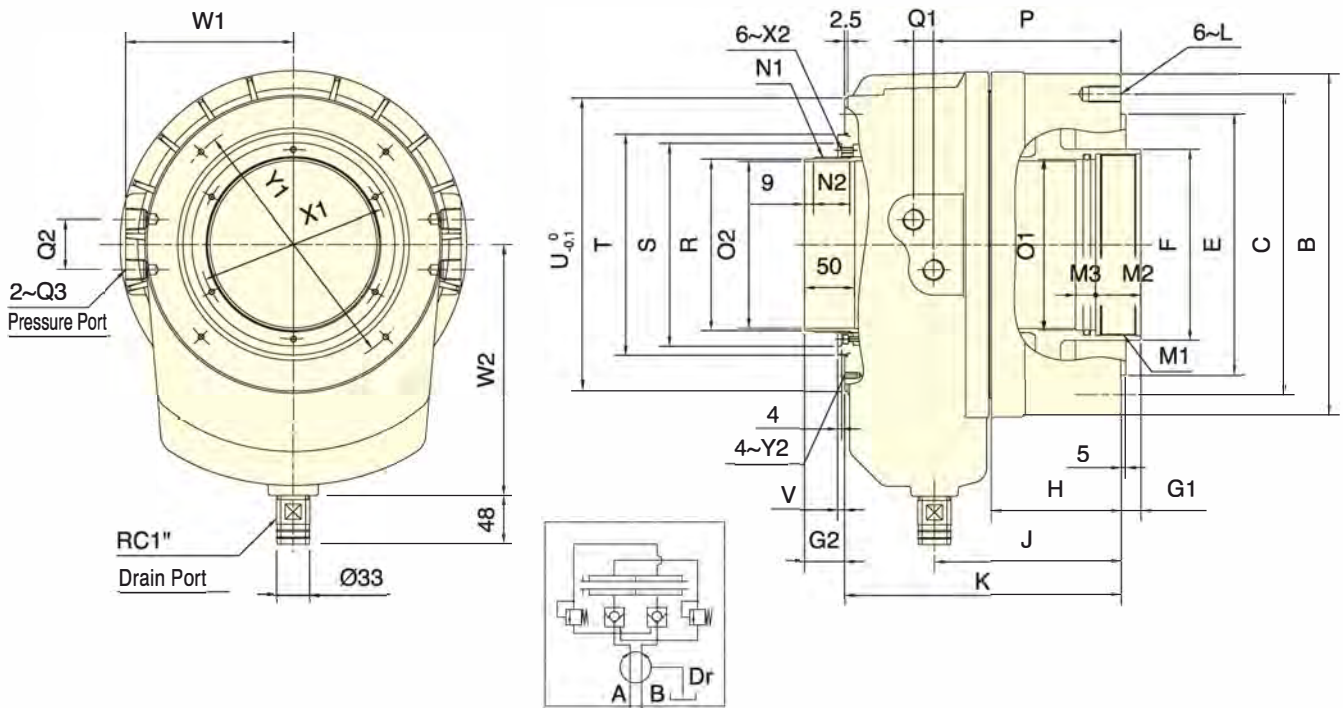

ROTARY CYLINDERS

### Specifications

Model	Eff. piston area cm <sup>2</sup>		Piston stroke (Dia.) (mm)	Max. speed min <sup>-1</sup> (r.p.m.)	Max. pressure MPa(kgf/cm <sup>2</sup> )	I kg-m <sup>2</sup> Moment of inertia	Weight (kg)	Total oil leakage lit./min.
	Extend	Retract						
TK-2416	418.4	375.4	35	2000	3.0 (30)	1.12	78	9
TK-2416L	418.4	375.4	51	2000	3.0 (30)	1.31	79.2	9
TK-2820	526.2	472.6	51	1600	3.0 (30)	2.4	134	10

### Dimensions

Model	A I.D.	B	C	E h7	F	G1max	G1min	G2max	G2min	H	J	K	L	M1	M2	M3	N1	N2	O1 H8	O2 H8	P	Q1	Q2	Q3	R g7	S H7	T	U	V	W1	W2	X1	X2	Y1	Y2
TK-2416	290	340	300	260	190	35	0	60	25	129	185.5	275	M16x32	M180x3	45	20	M174x2	38	170	166	186.5	20	50	RC1/2	171	202	220	292	7	167	250	188	M6x11	260	M6x12
TK-2416L	290	340	300	260	190	51	0	76	25	145	201.5	291	M16x32	M180x3	45	20	M174x2	52	170	166	202.5	20	50	RC1/2	171	202	220	292	7	167	250	188	M6x11	260	M6x12
TK-2820	340	395	360	320	235	51	0	76	25	152	212.5	316	M20x40	M220x3	45	20	M218x2	52	210	205	216	21	50	RC1/2	215	262	285	360	7	202.5	300	240	M6x12	320	M6x12



### Application/customer benefits

- Super high speed and light weight cylinder with large thru-hole
- Built-in check valve prevents the sudden decline of internal pressure ensuring that there is no workpiece slippage

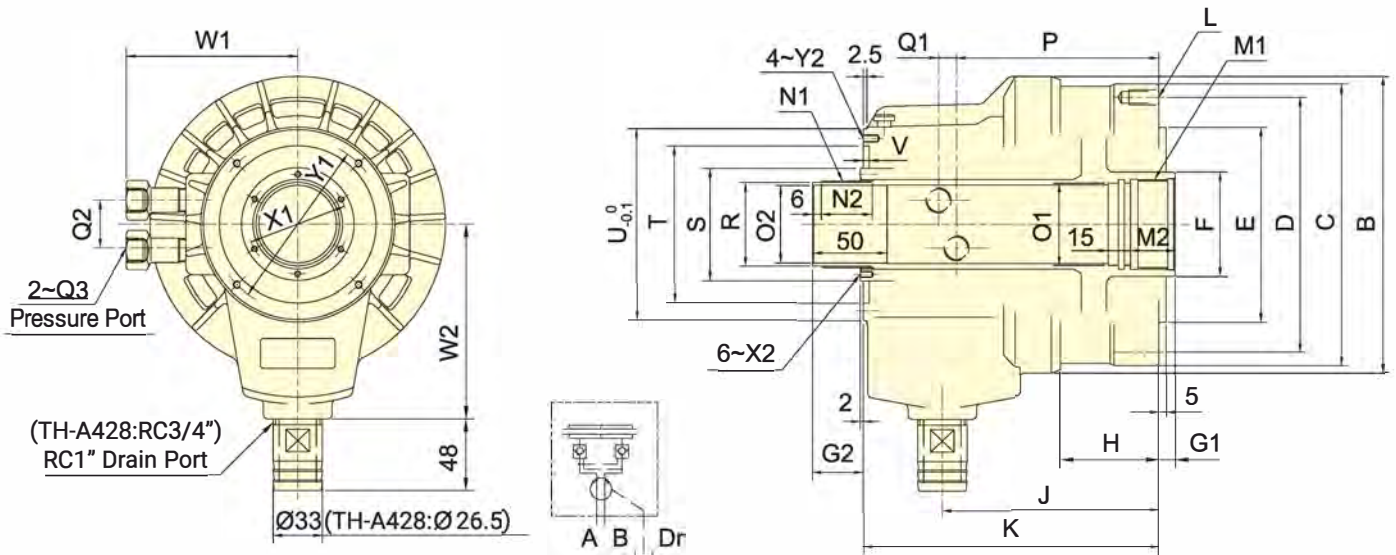

ROTARY CYLINDERS

### Specifications

Model	Eff. piston area cm <sup>2</sup>		Piston stroke (Dia.) (mm)	Max. speed min <sup>-1</sup> (r.p.m.)	Max. pressure MPa (kgf/cm <sup>2</sup> )	I kg·m <sup>2</sup> Moment of inertia	Weight (kg)	Total oil leakage lit./min.
	Extend	Retract						
TH-A428	52.2	49.5	10	8000	4.0(40)	0.02	5.6	3.0
TH-A536	69.8	67.5	15	8000	4.0(40)	0.05	8.3	3.0

### Dimensions

Model	A	B	C	D	E	F	G1	G1	G2	G2	H	J	K	L	M1	M2	N1	N2	O1	O2	P	Q1	Q2	Q3	R	S	T	U	V	W1	W2	X1	X2	Y1	Y2
	LD				h7		Max.	Min.	Max.	Min.									H8	H8					g7										
TH-A428	90	130	120	100	80	40	10	0	35	25	32	114.5	142	6-M8x15	M33x1.5	25	M34x1.5	26	30	28	88.5	11	24	RC1/4	32	45	65	86	4	72	105	-	-	76	M4x7
TH-A536	105	150	135	115	100	48	15	0	40	25	40	118	166	6-M10x20	M42x1.5	25	M44x1.5	28	38	36	111.5	10	24	RC1/4	42	55	73	98	4	80	110	-	-	83	M5x10





Application/customer benefits

- Compact, short form and light weight cylinder with thru-hole
- Patented built-in safety check and pressure relief valves
- Large feed and drain ports
- Can be mounted from the front or rear of the cylinder
- For use with vertical or horizontal spindles

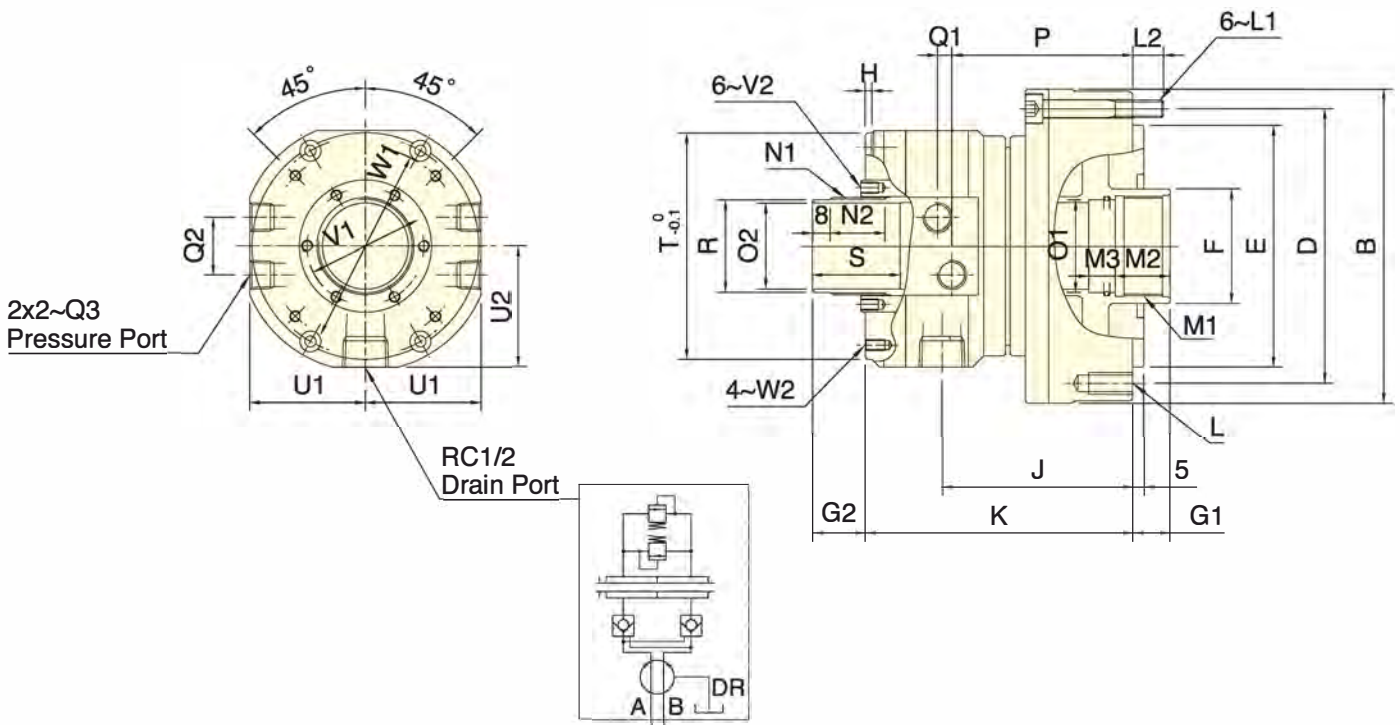

ROTARY CYLINDERS

Specifications

Model	Eff. piston area cm <sup>2</sup>		Piston stroke (Dia.) (mm)	Max. speed min <sup>-1</sup> (r.p.m.)	Max. pressure MPa (kgf/cm <sup>2</sup> )	I kg·m <sup>2</sup> Moment of inertia	Weight (kg)	Total oil leakage lit./min.
	Extend	Retract						
* TR-539	72.4	67.1	12	8000	40	0.01	6.8	3
* TR-646	105	93.9	15	7000	40	0.015	9.5	3

Dimensions

Model	A	B	C	D	E	F	G1	G1	G2	G2	H	J	K	L	L1	L2	M1	M2	M3	N1	N2	O1	O2	P	Q1	Q2	Q3	R	S	T	U1	U2	V1	V2	W1	W2	
	L.D				h7		Max.	Min.	Max.	Min.												H8	H8				RC1/4	g7	H7								
* TR-539	107	143	125	125	110	52	17	5	36	24	3	87	126	6-M10x20	M8x55	14	M45x1.5	25	12	M44x1.5	25	42	39	85.5	6.5	26	RC1/4	42	40	103	59	55	53	M5x8	90	M5x9	
* TR-646	128	165	147	147	130	65	15	0	34	19	3.5	97	135	12-M10x20	M8x60	11.5	M55x2	25	13	M52x1.5	25	50	46	93	6.5	32	RC3/8	50	50	116	52.5	62	62	M5x9	98	M5x9	

\*model produced only by order.

### Application/customer benefits

- Short form, light weight and high speed cylinder for closed hole applications
- Built-in safety check and pressure relief valves
- Can be mounted from the front or rear of the cylinder
- Requires drain port to be independently connected to the oil tank to avoid back pressure

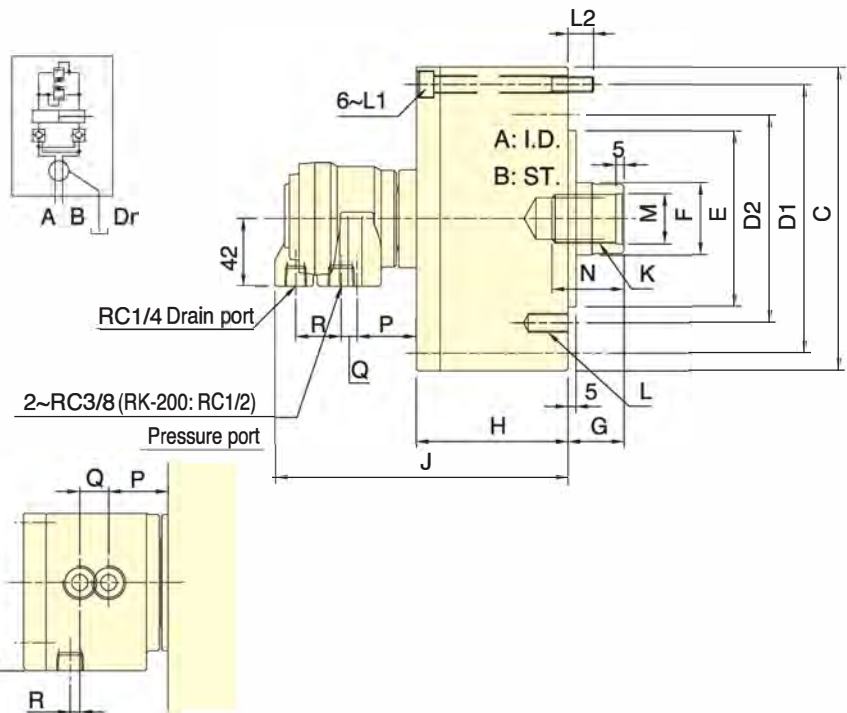
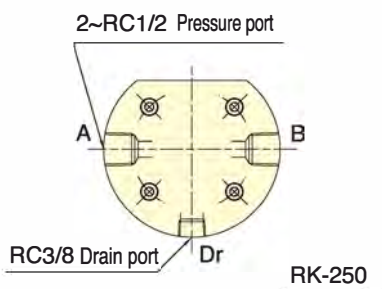
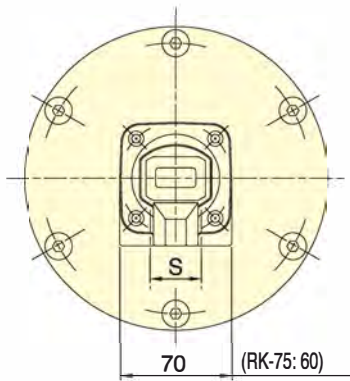

ROTARY CYLINDERS

### Specifications

Model	Eff. piston area cm <sup>2</sup>		Piston stroke (Dia.) (mm)	Max. speed min <sup>-1</sup> (r.p.m)	Max. pressure MPa(kgf/cm <sup>2</sup> )	I kg·m <sup>2</sup> Moment of inertia	Weight (kg)
	Extend	Retract					
RK-75	44.2	37.1	15	6000	4.0 (40)	0.01	2.9
RK-100	78.5	71.5	20	6000	4.0 (40)	0.03	4.4
RK-125	122.7	113.1	25	6000	4.0 (40)	0.05	6.9
RK-150	176.7	160.8	30	5500	4.0 (40)	0.09	9.5
RK-200	314.1	290.4	35	5500	4.0 (40)	0.28	15.4
RK-250	469.1	436	60	2000	5.0(50)	0.4	45.2

### Dimensions

Model	A	B	C	D1	D2	E h7	F	G max.	G min.	H	J	K	L	L1	L2	M H8	N	P	Q	R	S
RK-75	75	15	107	90	90	65	30	45	30	57	148	M20x2.5	6-M8x16	M8x60	12	21	35	41.5	10	27.5	26
RK-100	100	20	132	115	100	80	30	45	25	72	163	M20x2.5	6-M10x20	M8x75	12	21	35	39.5	10	28.5	32
RK-125	125	25	160	140	130	110	35	50	25	82	172	M24x3.0	6-M12x20	M8x85	12	25	45	38.5	10	28.5	32
RK-150	150	30	190	170	130	110	45	55	25	95	184	M30x3.5	12-M12x24	M10x100	16	32	45	37	10	28.5	32
RK-200	200	35	245	220	145	120	55	70	35	115	201	M36x4.0	12-M16x30	M10x125	21	38	60	38	6	28.5	28
RK-250	245	60	307	275	220	160	65	85	25	165	255	M42x3.0	12-M20x35	M16x175	28	45	65	33	18	6	-

### Application/customer benefits



- Short form, lightweight and high speed cylinder for closed hole applications
- Built-in safety check and pressure relief valves
- Can be mounted from the front or rear of the cylinder
- Requires drain port to be independently connected to the oil tank to avoid back pressure

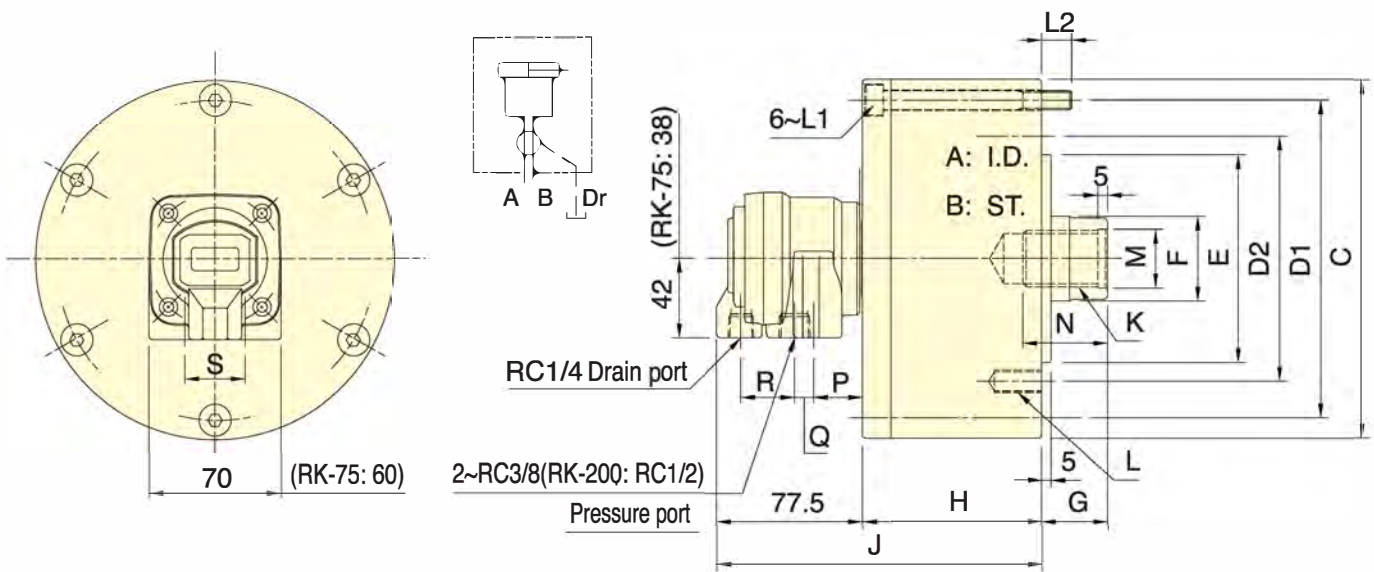

ROTARY CYLINDERS

### Specifications

Model	Eff. piston area cm <sup>2</sup>		Piston stroke (Dia.) (mm)	Max. speed min <sup>-1</sup> (r.p.m.)	Max. pressure MPa(kgf/cm <sup>2</sup> )	I kg·m <sup>2</sup> Moment of inertia	Weight (kg)
	Extend	Retract					
RK-75N	44.2	37.1	15	6000	4.0(40)	0.01	2.8
RK-100N	78.5	71.5	20	6000	4.0(40)	0.03	4.3
RK-125N	122.7	113.1	25	6000	4.0(40)	0.05	6.8
RK-150N	176.7	160.8	30	5500	4.0(40)	0.09	9.4
RK-200N	314.1	290.4	35	5500	4.0(40)	0.28	15.3
RK-250N	469.1	436	60	2000	5.0(50)	0.4	45.2

### Dimensions

Model	A	B	C	D1	D2	E h7	F	G max.	G min.	H	J	K	L	L1	L2	M H8	N	P	Q	R	S
RK-75N	75	15	107	90	90	65	30	45	30	57	134	M20x2.5	6~M8x16	M8x60	12	21	35	28	10	27.5	26
RK-100N	100	20	132	115	100	80	30	45	25	72	149	M20x2.5	6~M10x20	M8x75	12	21	35	26	10	28.5	32
RK-125N	125	25	160	140	130	110	35	50	25	82	159	M24x3.0	6~M12x20	M8x85	12	25	45	26	10	28.5	32
RK-150N	150	30	190	170	130	110	45	55	25	95	172	M30x3.5	12~M12x24	M10x100	16	32	45	26	10	28.5	32
RK-200N	200	35	245	220	145	120	55	70	35	115	192	M36x4.0	12~M16x30	M10x125	21	38	60	30	6	28.5	28
RK-250N	245	60	307	275	220	160	65	85	25	165	255	M42 x 3.0	6~M20 x 2.5	M16x175	28	45	65	37	18	6	-



### Application/customer benefits



- Rotary valve and cylinder body are made of a special light weight alloy
- Unique design allows lubrication of the bearing in the rotary valve allowing for higher speeds and longer life
- Requires drain port to be independently connected to the oil tank to avoid back pressure

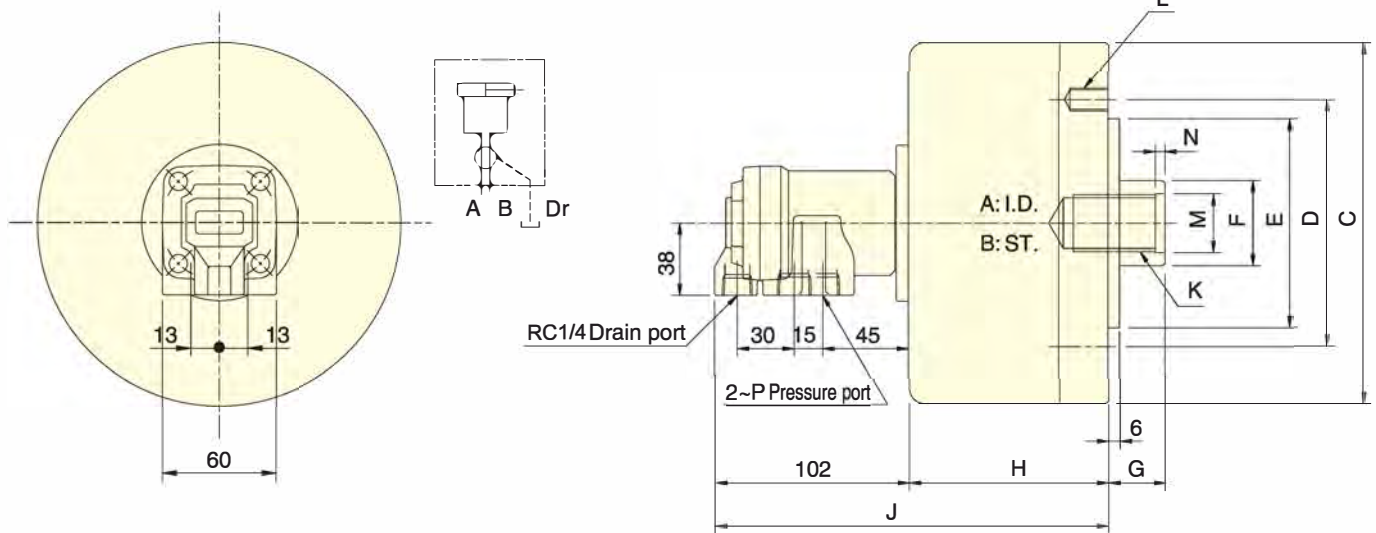

ROTARY CYLINDERS

### Specifications

Model	Eff. piston area cm <sup>2</sup>		Piston stroke (Dia.) (mm)	Max. speed min <sup>-1</sup> (r.p.m.)	Max. pressure MPa(kgf/cm <sup>2</sup> )	I kgm <sup>2</sup> Moment of inertia	Weight (kg)
	Extend	Retract					
RH-65	31	27.9	15	6000	3.5(35)	0.01	2.9
RH-80	47.7	42.8	15	6000	3.5(35)	0.01	3.4
RH-100	75.4	70.5	20	5500	3.5(35)	0.04	4.9
RH-125	119.6	112.5	25	5500	3.5(35)	0.08	6.8

### Dimensions

Model	A	B	C	D	E h7	F	G max.	G min.	H	J	K	L	M H8	N	P
RH-65	65	15	98	80	60	22	45	30	74	175	M12x1.75x30	6~M8x16	14	4	RC3/8
RH-80	80	15	112	90	65	25	45	30	74	175	M16x2.0x30	6~M8x16	17	4	RC3/8
RH-100	100	20	135	100	80	25	45	25	89	190	M16x2.0x30	6~M10x20	17	4	RC3/8
RH-125	125	25	160	130	110	30	50	25	96	197	M20x2.5x35	6~M12x20	21	4	RC3/8





### Application/customer benefits

- Short form with high speed and stroke control
- Built-in safety check and pressure relief valves
- Can be mounted from the front or rear of the cylinder
- Requires drain port to be independently connected to the oil tank to avoid back pressure

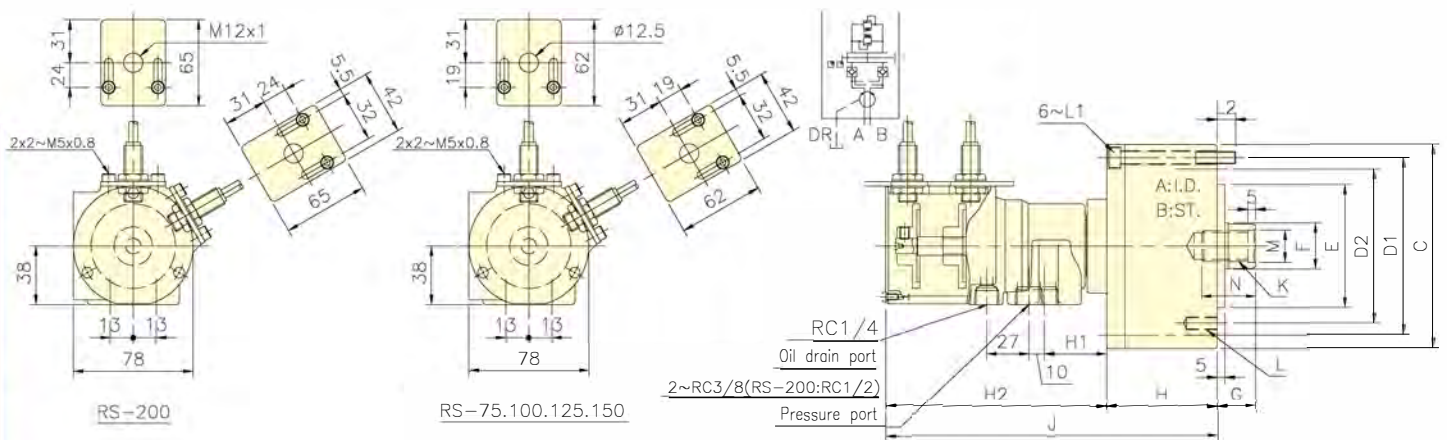

ROTARY CYLINDERS

### Specifications

Model	Eff. piston area cm <sup>2</sup>		Piston stroke (Dia.) (mm)	Max. speed min <sup>-1</sup> (r.p.m.)	Max. pressure MPa (kgf/cm <sup>2</sup> )	I kg·m <sup>2</sup> Moment of inertia	Weight (kg)
	Extend	Retract					
RS-75	43	37.1	15	6000	4.0 (40)	0.01	3.4
RS-100	77.4	71.5	20	6000	4.0 (40)	0.04	4.9
RS-125	121.6	113.1	25	6000	4.0 (40)	0.05	7.4
RS-150	175.6	160.8	30	5500	4.0 (40)	0.1	10.7
RS-200	313	290.4	35	5500	4.0 (40)	0.29	15.9

### Dimensions

Model	A	B	C	D1	D2	E h7	F	G max.	G min.	H	H1	H2	J	K	L	L1	L2	M H8	N
RS-75	75	15	107	90	90	65	30	45	30	57	42	145	202	M20x2.5	6~M8x16	M8x60	12	21	35
RS~100	100	20	132	115	100	80	30	45	25	72	42	145	217	M20x2.5	6~M10x20	M8x75	12	21	35
RS~125	125	25	160	140	130	110	35	50	25	82	41	144	226	M24x3.0	6~M12x20	M8x85	12	25	45
RS~150	150	30	190	170	130	110	45	55	25	95	39	142	237	M30x3.5	12~M12x24	M10x100	16	32	45
RS~200	200	35	245	220	145	120	55	70	35	115	36	142.5	257.5	M36x4.0	12~M16x30	M10x125	21	38	60

Proximity sensor: Model IA12DLF02N03219(CARLO) DC 10~30V 200mA NPN



### Application/customer benefits

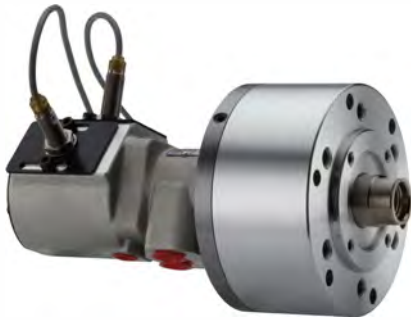

- Short form with high speed and stroke control
- Built-in safety check and pressure relief valves
- Can be mounted from the front or rear of the cylinder
- Requires drain port to be independently connected to the oil tank to avoid back pressure

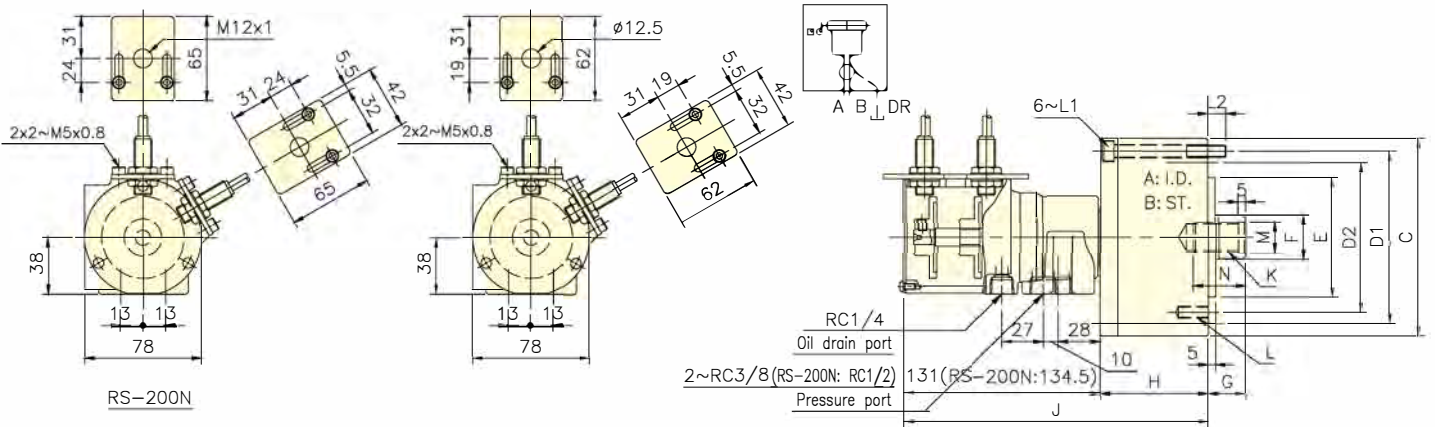

### Specifications

Model	Eff. piston area cm <sup>2</sup>		Piston stroke (Dia.) (mm)	Max. speed min <sup>-1</sup> (r.p.m.)	Max. pressure MPa (kgf/cm <sup>2</sup> )	I kg·m <sup>2</sup> Moment of inertia	Weight (kg)
	Extend	Retract					
RS-6520N	32	28.3	20	6000	4.0(40)	0.01	3.2
RS-6530N	32	28.3	30	6000	4.0(40)	0.01	3.3
RS-75N	43	37.1	15	6000	4.0(40)	0.01	3.3
RS-7530N	43	37.1	30	6000	4.0(40)	0.013	3.7
RS-100N	77.4	71.5	20	6000	4.0(40)	0.04	4.8
RS-125N	121.6	113.1	25	6000	4.0(40)	0.05	7.3
RS-150N	175.6	160.8	30	5500	4.0(40)	0.16	10.6
RS-200N	313	290.4	35	5500	4.0(40)	0.29	15.9

### Dimensions

Model	A	B	C	D1	D2	E h7	F	G max.	G min.	H	J	K	L	L1	L2	M±8	N
RS-6520N	65	20	97	80	80	60	25	45	25	62	193	M16x2.0	6~M8x16	M6x70	14.5	17	30
RS-6530N	65	30	97	80	80	60	25	45	15	62	203	M16x2.0	6~M8x16	M6x80	14.5	17	30
RS-75N	75	15	107	90	90	65	30	45	30	57	188	M20x2.5	6~M8x16	M8x60	12	21	35
RS-7530N	75	30	107	90	90	65	30	45	15	72	203	M20x2.5	6~M8x16	M8x75	12	21	35
RS-100N	100	20	132	115	100	80	30	45	25	72	203	M20x2.5	6~M10x20	M8x75	12	21	35
RS-125N	125	25	160	140	130	110	35	50	25	82	213	M24x3.0	6~M12x20	M8x85	12	25	45
RS-150N	150	30	190	170	130	110	45	55	25	95	226	M30x3.5	12~M12x24	M10x100	16	32	45
RS-200N	200	35	245	220	145	120	55	75	35	115	249.5	M36x4.0	12~M16x30	M10x125	21	38	60

Proximity sensor: Model IA12DLF02N03219(CARLO) DC 10~30V 200mA NPN

### Application/customer benefits

- Allows coolant to be fed from the rear of the distributor through a rotating union
- Built-in safety check and pressure relief valves
- Requires drain port to be independently connected to the oil tank to avoid back pressure
- Rotary cylinder requires liquid through the coolant port

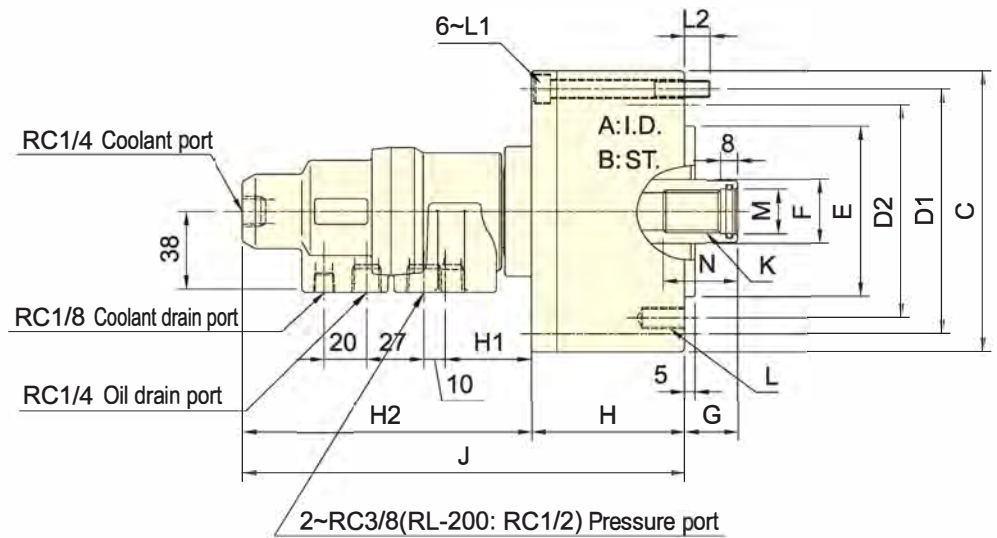
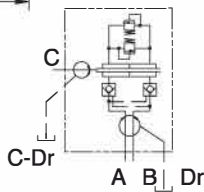
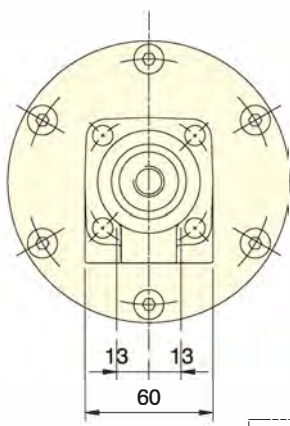

ROTARY CYLINDERS

PV Limit value 14400 MPa r/m

### Specifications

Model	Eff. piston area cm <sup>2</sup>		Piston stroke (Dia.) (mm)	Max. speed min <sup>-1</sup> (r.p.m.)	Max. pressure MPa (kgf/cm <sup>2</sup> )	Coolant connection Max.pressure MPa(kgf/cm <sup>2</sup> )	I kg·m <sup>2</sup> Moment of inertia	Weight (kg)
	Extend	Retract						
RL-75	42.6	37.1	15	6000	4.0(40)	3.5(35)	0.01	3.1
RL-100	77	71.5	20	6000	4.0(40)	3.5(35)	0.04	4.6
RL-125	121.2	113.1	25	6000	4.0(40)	3.5(35)	0.06	7.1
RL-150	175.2	160.8	30	5500	4.0(40)	3.5(35)	0.1	9.7
RL-200	312.5	290.4	35	5500	4.0(40)	3.5(35)	0.3	15.6

### Dimensions

Model	A	B	C	D1	D2	E h7	F	G max.	G min.	H	H1	H2	J	K	L	L1	L2	M H8	N
RL-75	75	15	107	90	90	65	30	45	30	57	42	137	194	M20x2.5	6~M8x16	M8x60	12	21	35
RL-100	100	20	132	115	100	80	30	45	25	72	42	137	209	M20x2.5	6~M10x20	M8x75	12	21	35
RL-125	125	25	160	140	130	110	35	50	25	82	41	136	218	M24x3.0	6~M12x20	M8x85	12	25	45
RL-150	150	30	190	170	130	110	45	55	25	95	39	134	230	M30x3.5	12~M12x24	M10x100	16	32	45
RL-200	200	35	245	220	145	120	55	70	35	115	36	132	248	M36x4.0	12~M16x30	M10x125	21	38	60

### Application/customer benefits

- Allows coolant to be fed from the rear of the distributor through a rotating union
- Built-in safety check and pressure relief valves
- Requires drain port to be independently connected to the oil tank to avoid back pressure
- Rotary cylinder requires liquid through the coolant port

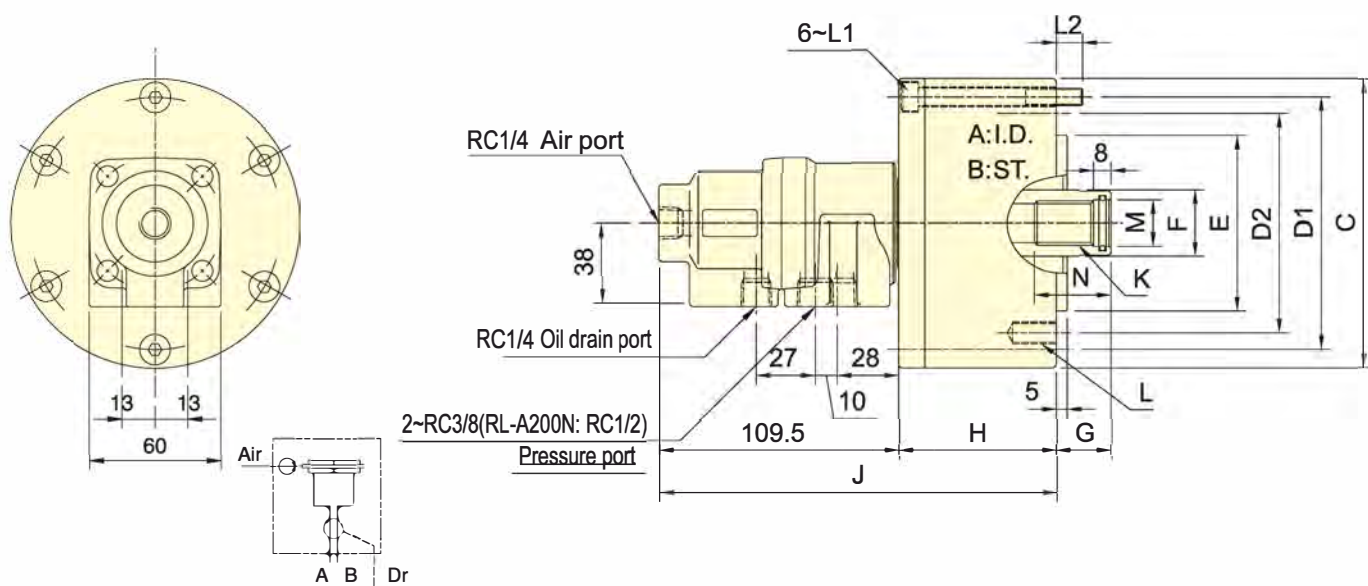

PV Limit value 14400 MPa r/m

ROTARY CYLINDERS

### Specifications

Model	Eff. piston area cm <sup>2</sup>		Piston stroke (Dia.) (mm)	Max. speed min <sup>-1</sup> (r.p.m.)	Max. pressure MPa (kgf/cm <sup>2</sup> )	Coolant connection Max. pressure MPa(kgf/cm <sup>2</sup> )	I kg·m <sup>2</sup> Moment of inertia	Weight (kg)
	Extend	Retract						
RL-75N	42.6	37.1	15	6000	4.0 (40)	3.5(35)	0.01	3
RL-100N	77	71.5	20	6000	4.0 (40)	3.5(35)	0.04	4.5
RL-125N	121.2	113.1	25	6000	4.0 (40)	3.5(35)	0.06	7
RL-150N	175.2	160.8	30	5500	4.0 (40)	3.5(35)	0.1	9.6
RL-200N	312.5	290.4	35	5500	4.0 (40)	3.5(35)	0.29	15.5

### Dimensions

Model	A	B	C	D1	D2	E h7	F	G max.	G min.	H	J	K	L	L1	L2	M H8	N
RL-75N	75	15	107	90	90	65	30	45	30	57	180	M20x2.5	6-M8x16	M8x60	12	21	35
RL-100N	100	20	132	115	100	80	30	45	25	72	195	M20x2.5	6-M10x20	M8x75	12	21	35
RL-125N	125	25	160	140	130	110	35	50	25	82	205	M24x3.0	6-M12x20	M8x85	12	25	45
RL-150N	150	30	190	170	130	110	45	55	25	95	218	M30x3.5	12-M12x24	M10x100	16	32	45
RL-200N	200	35	245	220	145	120	55	70	35	115	240	M36x4.0	12-M16x 30	M10x125	21	38	60



### Application/customer benefits

- Allows compressed air to be fed from the rear of the distributor through a rotating union
- Can be mounted from the front or rear of the cylinder

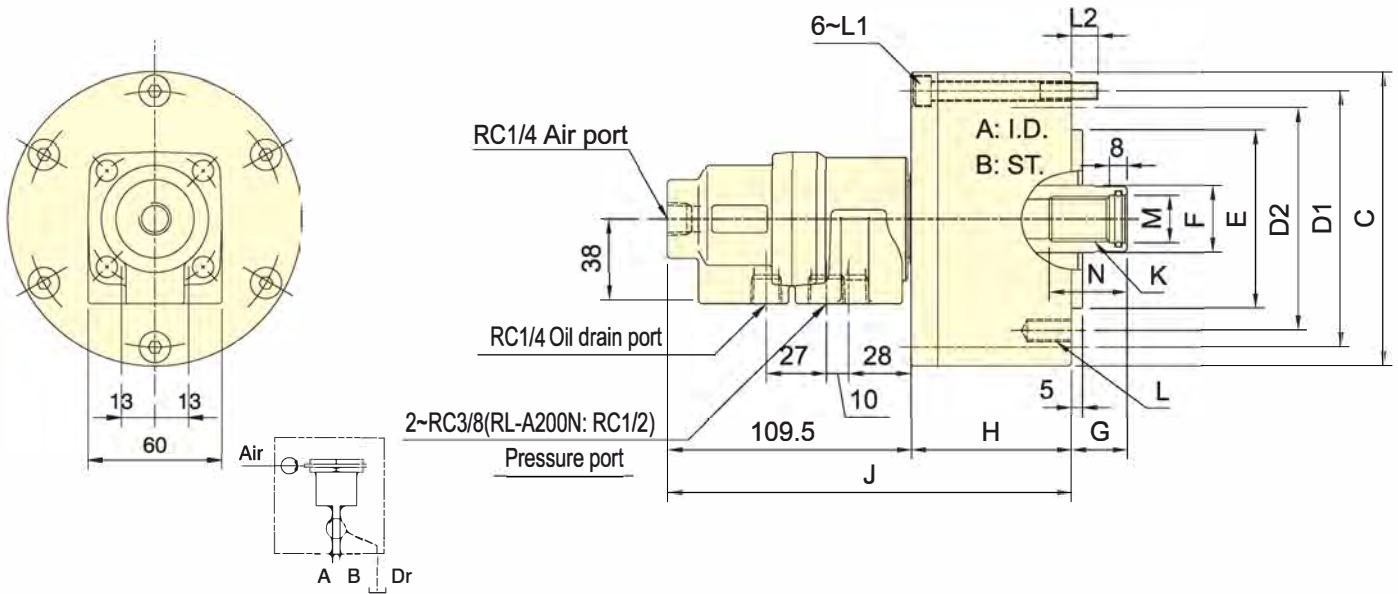

ROTARY CYLINDERS

### Specifications

Model	Eff. piston area cm <sup>2</sup>		Piston stroke (Dia.) (mm)	Max. speed min <sup>-1</sup> (r.p.m.)	Max. pressure MPa (kgf/cm <sup>2</sup> )	Air connection Max. pressure MPa(kgf/cm <sup>2</sup> )	I kg·m <sup>2</sup> Moment of inertia	Weight (kg)
	Extend	Retract						
RL- A75N	42.6	37.1	15	6000	4.0(40)	0.8(8)	0.01	3
RL- A100N	77	71.5	20	6000	4.0(40)	0.8(8)	0.04	4.5
RL- A125N	121.2	113.1	25	6000	4.0(40)	0.8(8)	0.06	7
RL- A150N	175.2	160.8	30	5500	4.0(40)	0.8(8)	0.1	9.6
RL- A200N	312.5	290.4	35	5500	4.0(40)	0.8(8)	0.29	15.5

### Dimensions

Model	A	B	C	D1	D2	E h7	F	G max.	G min.	H	J	K	L	L1	L2	M H8	N
RL- A75N	75	15	107	90	90	65	30	45	30	57	166	M20 x2.5	6~M8x16	M8x60	12	21	35
RL- A100N	100	20	132	115	100	80	30	45	25	72	181	M20 x2.5	6~M10x20	M8x75	12	21	35
RL- A125N	125	25	160	140	130	110	35	50	25	82	191	M24x 3.0	6~M12x20	M8x85	12	25	45
RL- A150N	150	30	190	170	130	110	45	55	25	95	204	M30x3.5	12~M12x24	M10x100	16	32	45
RL- A200N	200	35	245	220	145	120	55	70	35	115	225	M36 x4.0	12~M16x30	M10x125	21	38	60



Application/customer benefits

- Short form and lightweight with high speed
- Built-in safety check and pressure relief valves
- Can be mounted from the front or rear of the cylinder
- Requires drain port to be independently connected to the oil tank to avoid back pressure

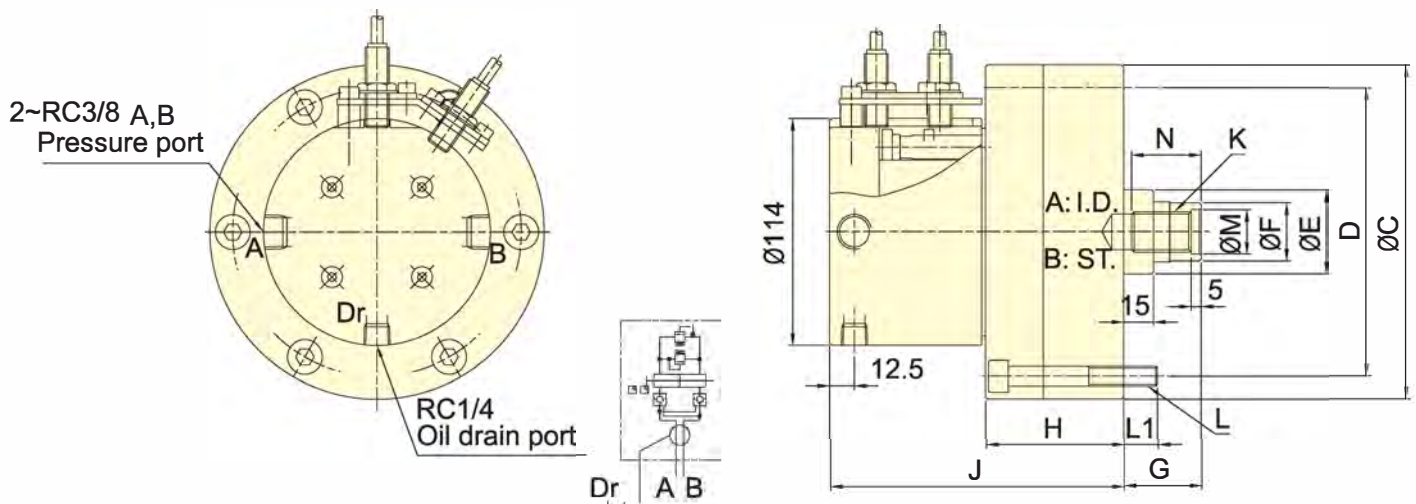

ROTARY CYLINDERS

Specifications

Model	Eff. piston area cm <sup>2</sup>		Piston stroke (Dia.) (mm)	Max. speed min <sup>-1</sup> (r.p.m.)	Max. pressure MPa (kgf/cm <sup>2</sup> )	I kg·m <sup>2</sup> Moment of inertia	Weight (kg)
	Extend	Retract					
RE-110	92.7	87.9	20	6000	3.5(35)	0.02	6.9
RE-120	110.8	106	21	6000	4.0(40)	0.03	8.8
RE-130	130.4	123.1	30	6000	4.0(40)	0.03	9.1

Dimensions

Model	A	B	C	D	E h7	F	G max.	G min.	H	J	K	L	L1	M H8	N
RE-110	110	20	145	128	42	29	60	40	66	146	M20x2.5	6~M8x70	12	22	35
RE-120	120	21	168	145	42	29	60	39	69.5	148	M20x2.5	6~M10x75	17	22	35
RE-130	130	30	168	150	50	33	60	30	79.5	158	M24x3.0	6~M10x85	17	27	40



### Application/customer benefits

- Short form, lightweight and high speed for vertical applications
- Built-in safety check and pressure relief valves
- Can be mounted from the front or rear of the cylinder
- Requires drain port to be independently connected to the oil tank to avoid back pressure

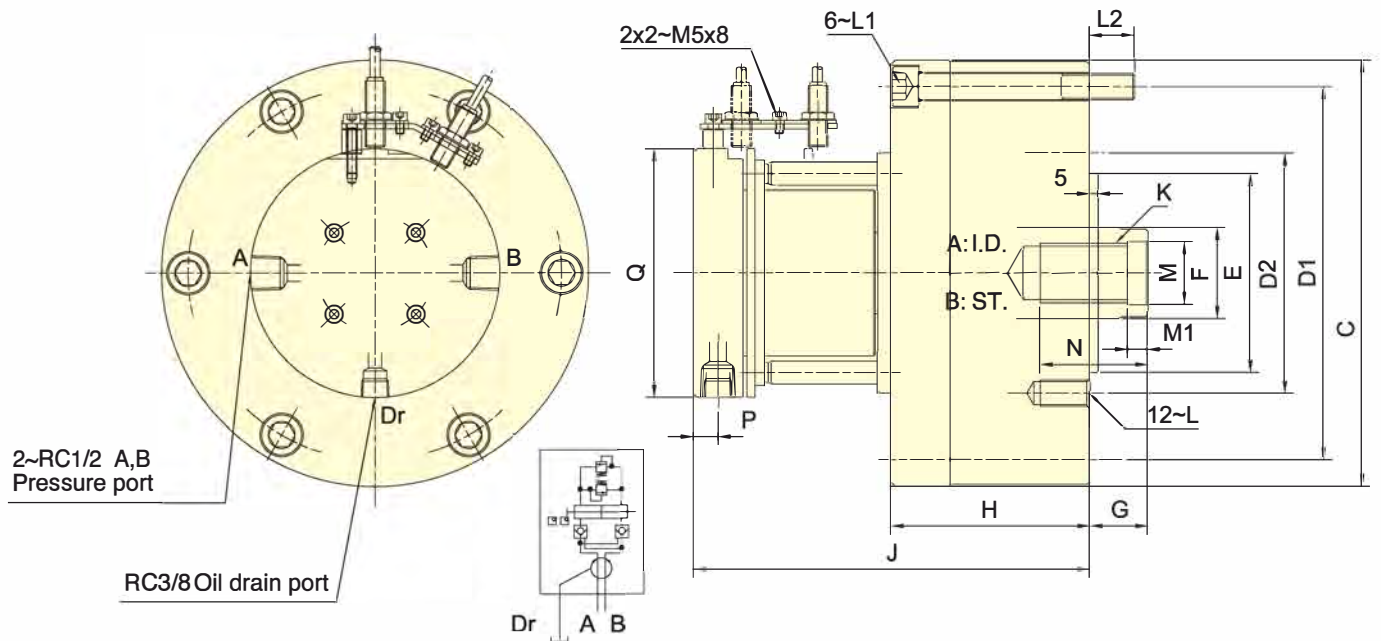

ROTARY CYLINDERS

### Specifications

Model	Eff. piston area cm <sup>2</sup>		Piston stroke (Dia.) (mm)	Max. speed min <sup>-1</sup> (r.p.m.)	Max. pressure MPa (kgf/cm <sup>2</sup> )	I kg·m <sup>2</sup> Moment of inertia	Weight (kg)
	Extend	Retract					
RE-150	174.4	160.8	30	5500	4.0 (40)	0.06	14.9
RE-200K	292.4	274.9	35	4000	4.0 (40)	0.19	29.1
RE-200L	292.4	265.4	50	4000	5.0 (50)	0.21	30.4
RE-250	465.2	438.2	60	2000	5.0 (50)	0.43	47.2

### Dimensions

Model	A	B	C	D1	D2	E h7	F	G max.	G min.	H	J	K	L	L1	L2	M H8	M1	N	P	Q
RE-150	150	30	205	180	130	110	45	60	30	99	177.5	M30x3.5	M12x24	M12x105	18.5	32	10	50	12.5	114
RE-200K	195	35	257	225	145	120	55	73	38	120	239	M36x4.0	M16x30	M16x130	27	38	12	65	15	150
RE-200L	195	50	257	225	170	125	65	80	30	135	254	M42x3.0	M16x30	M16x145	27	45	12	65	15	150
RE-250	245	60	307	275	220	160	65	85	25	165	280	M42x3.0	M20x35	M16x175	28	45	12	65	15	150

Proximity sensor: Model IA12DLF02N03219(CARLO) DC 10~30V 200mA NPN





Application/customer benefits

- Short form, lightweight and high speed that allows compressed air to be fed from the rear of the distributor through a rotating union
- Built-in safety check and pressure relief valves
- Can be mounted from the front or rear of the cylinder
- Requires drain port to be independently connected to the oil tank to avoid back pressure

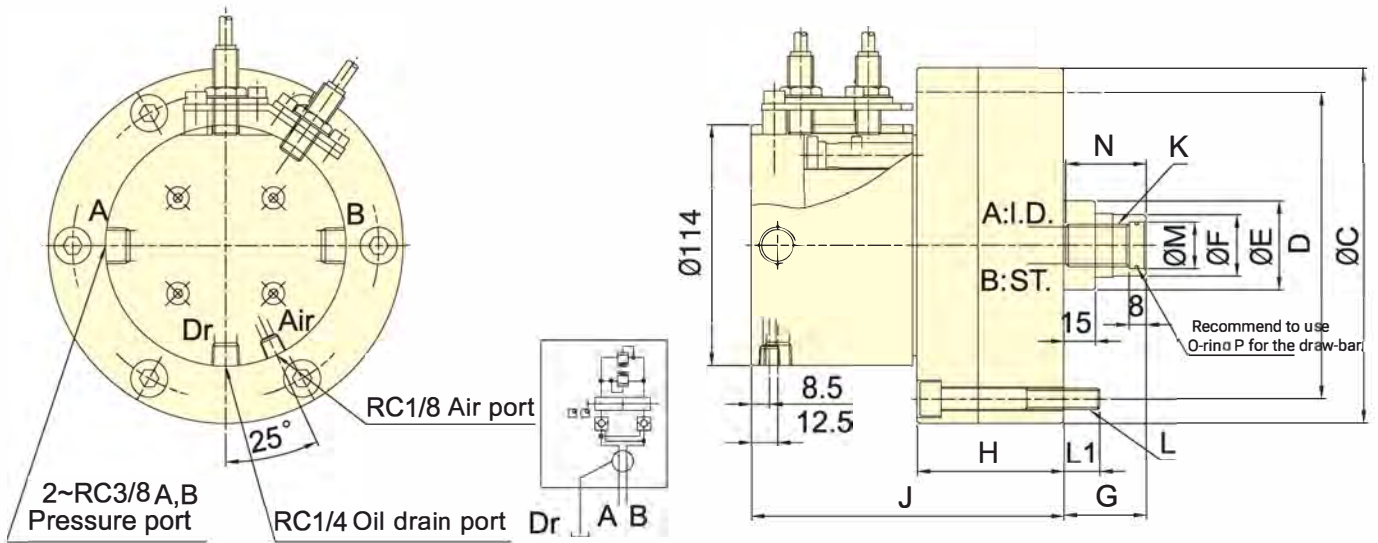

ROTARY CYLINDERS

Specifications

Model	Eff. piston area cm <sup>2</sup>		Piston stroke (Dia.) (mm)	Max. speed min <sup>-1</sup> (r.p.m.)	Max. pressure MPa(kgf/cm <sup>2</sup> )	Air connection Max.pressure MPa(kgf/cm <sup>2</sup> )	I kg·m <sup>2</sup> Moment of inertia	Weight (kg)
	Extend	Retract						
RE-A110	91.2	87.9	20	6000	4.0(40)	0.8(8)	0.02	6.9
RE-A120	109.3	106	21	6000	4.0(40)	0.8(8)	0.02	8.8
RE-A130	128.9	123.1	30	6000	4.0(40)	0.8(8)	0.03	9.1

Dimensions

Model	A	B	C h7	D	E	F	G max.	G min.	H	J	K	L	L1	M H8	N	P
RE-A110	110	20	145	128	42	29	60	40	66	146	M20x2.5	6~M8x70	12	22	38	S20
RE-A120	120	21	168	145	42	29	60	39	69.5	148	M20x2.5	6~M10x75	17	22	38	S20
RE-A130	130	30	168	150	50	33	60	30	79.5	158	M24x3.0	6~M10x85	17	27	43	S24



**Application/customer benefits**

- Short form, lightweight and high speed that allows compressed air to be fed from the rear of the distributor through a rotating union
- Built-in safety check and pressure relief valves
- Can be mounted from the front or rear of the cylinder
- Requires drain port to be independently connected to the oil tank to avoid back pressure

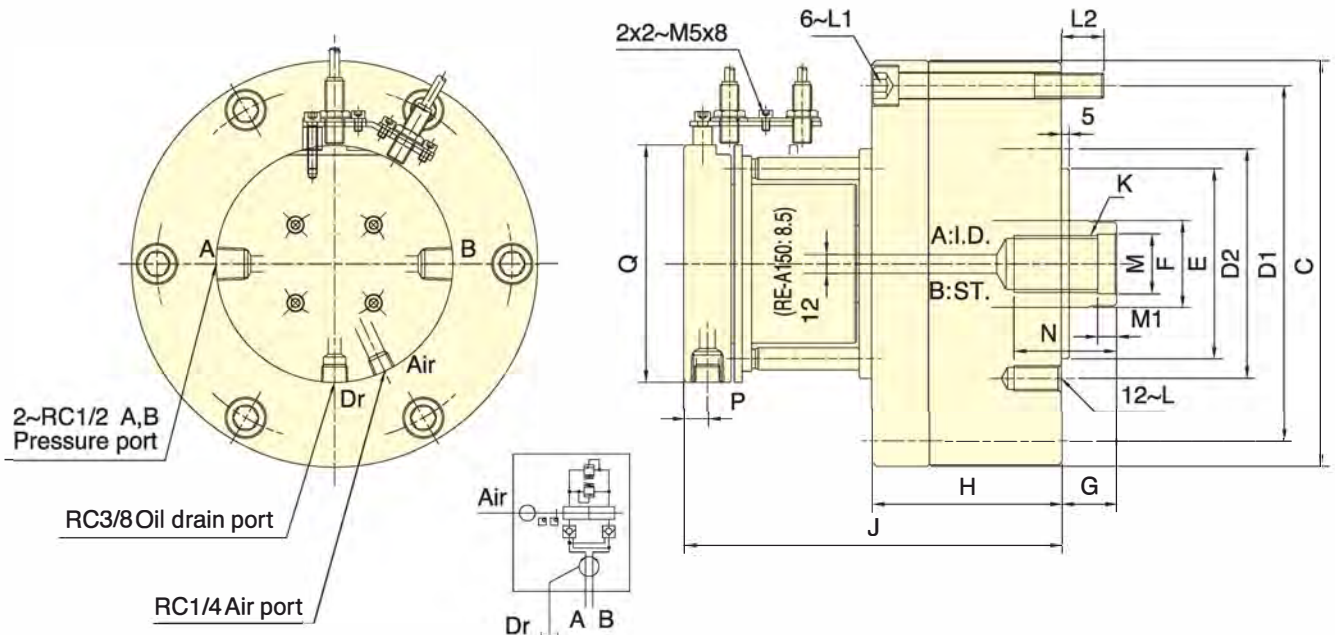

ROTARY CYLINDERS

**Specifications**

Model	Eff. piston area cm <sup>2</sup>		Piston stroke (Dia.) (mm)	Max. speed min <sup>-1</sup> (r.p.m.)	Max. pressure MPa(kgf/cm <sup>2</sup> )	Air connection Max. pressure MPa(kgf/cm <sup>2</sup> )	I kg·m <sup>2</sup> Moment of inertia	Weight (kg)
	Extend	Retract						
RE-A150	174.4	160.8	30	5500	4.0(40)	0.8(8)	0.06	14.9
RE-A200K	292.4	274.9	35	4000	4.0(40)	0.8(8)	0.19	29.1
RE-A200L	292.4	265.4	50	4000	5.0(50)	0.8(8)	0.21	30.4
RE-A250	465.2	438.2	60	2000	5.0(50)	0.8(8)	0.43	47.2

**Dimensions**

Model	A	B	C	D1	D2	E h7	F	G max.	G min.	H	J	K	L	L1	L2	M H8	M1	N	P	Q
RE-A150	150	30	205	180	130	110	45	60	30	99	177.5	M30x3.5	M12x24	M12x105	18.5	32	10	50	12.5	114
RE-A200K	195	35	257	225	145	120	55	73	38	120	239	M36x4.0	M16x30	M16x130	27	38	12	65	15	150
RE-A200L	195	50	257	225	170	125	65	80	30	135	254	M42x3.0	M16x30	M16x145	27	45	12	65	15	150
RE-A250	245	60	307	275	220	160	65	85	25	165	280	M42x3.0	M20x35	M16x175	28	45	12	65	15	150



### Application/customer benefits

- Short form, lightweight and high speed that allows coolant to be fed from the rear of the distributor through a rotating union
- Built-in safety check and pressure relief valves
- Can be mounted from the front or rear of the cylinder
- Requires drain port to be independently connected to the oil tank to avoid back pressure

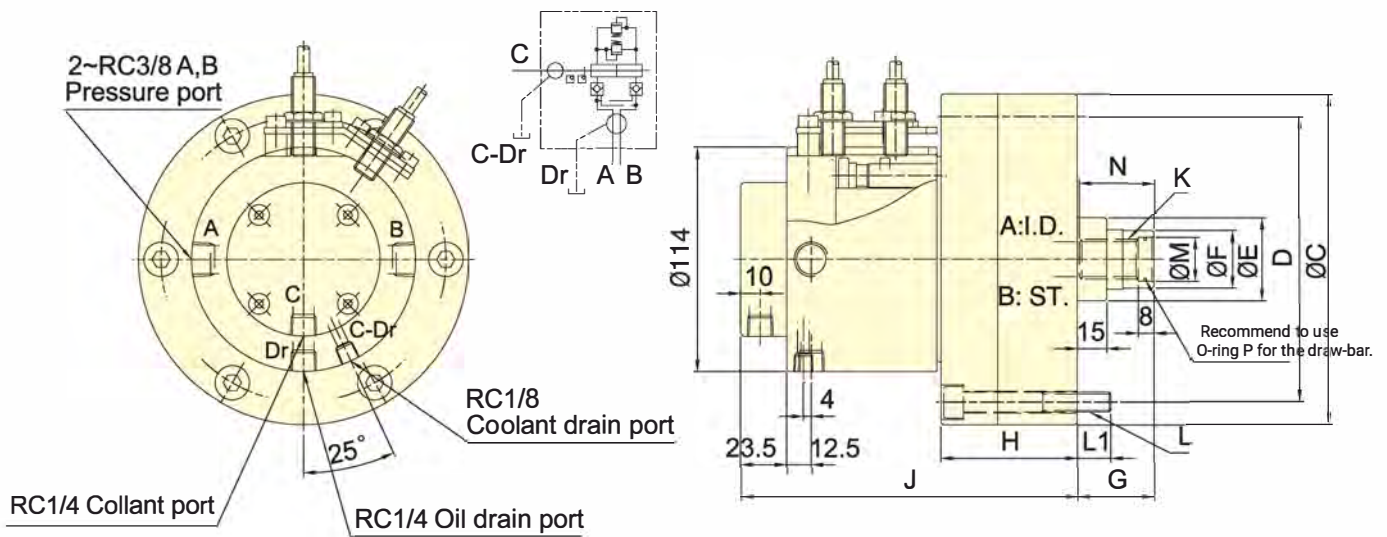

ROTARY CYLINDERS

### Specifications

Model	Eff. piston area cm <sup>2</sup>		Piston stroke (Dia.) (mm)	Max. speed min <sup>-1</sup> (r.p.m.)	Max. pressure MPa(kgf/cm <sup>2</sup> )	Coolant connection Max. pressure MPa(kgf/cm <sup>2</sup> )	I kg·m <sup>2</sup> Moment of inertia	Weight (kg)
	Extend	Retract						
RE-L110	92.7	87.9	20	6000	4.0(40)	1.5(15)	0.02	7.2
RE-L120	110.8	106	21	6000	4.0(40)	1.5(15)	0.03	9.1
RE-L130	128.9	123.1	30	6000	4.0(40)	1.5(15)	0.03	9.5

### Dimensions

Model	A	B	C h7	D	E	F	G max.	G min.	H	J	K	L	L1	M H8	N	P
RE-L110	110	20	145	128	42	29	60	40	66	169.5	M20x2.5	6~M8x70	12	22	38	S20
RE-L120	120	21	168	145	42	29	60	39	69.5	171.5	M20x2.5	6~M10x75	17	22	38	S20
RE-L130	130	30	168	150	50	33	60	30	79.5	181.5	M24x3.0	6~M10x85	17	27	43	S24





Application/customer benefits

- Short form, lightweight and high speed that allows coolant to be fed from the rear of the distributor through a rotating union
- Built-in safety check and pressure relief valves
- Can be mounted from the front or rear of the cylinder
- Requires drain port to be independently connected to the oil tank to avoid back pressure

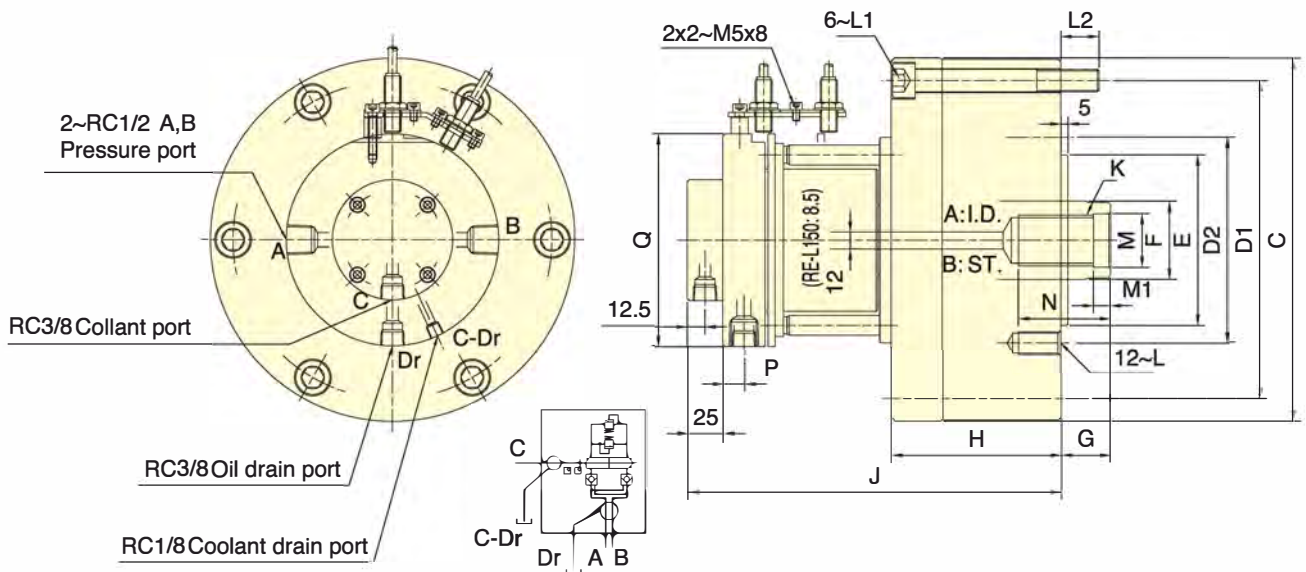

ROTARY CYLINDERS

Specifications

Model	Eff. piston area cm <sup>2</sup>		Piston stroke (Dia.) (mm)	Max. speed min <sup>-1</sup> (r.p.m.)	Max. pressure MPa(kgf/cm <sup>2</sup> )	Coolant connection Max. pressure MPa(kgf/cm <sup>2</sup> )	I kg·m <sup>2</sup> Moment of inertia	Weight (kg)
	Extend	Retract						
RE-L150	174.4	160.8	30	5500	4.0(40)	1.5(15)	0.06	15.2
RE-L200K	292.4	274.9	35	4000	4.0(40)	1.5(15)	0.19	29.4
RE-L200L	292.4	265.4	50	4000	5.0(50)	1.5(15)	0.21	30.7
RE-L250	465.2	438.2	60	2000	5.0(50)	1.5(15)	0.43	47.5

Dimensions

Model	A	B	C	D1	D2	E h7	F	G max.	G min.	H	J	K	L	L1	L2	M H8	M1	N	P	Q
RE-L150	150	30	205	180	130	110	45	60	30	99	201	M30x3.5	M12x24	M12x105	18.5	32	10	50	12.5	114
RE-L200K	195	35	257	225	145	120	55	73	38	120	264	M36x4.0	M16x30	M16x130	27	38	12	65	15	150
RE-L200L	195	50	257	225	170	125	65	80	30	135	279	M42x3.0	M16x30	M16x145	27	45	12	65	15	150
RE-L250	245	60	307	275	220	160	65	85	25	165	305	M42x3.0	M20x35	M16x175	28	45	12	65	15	150

Proximity sensor: Model IA12DLF02N03219(CARLO) DC 10~30V 200mA NPN

### Application/customer benefits



- Short form and lightweight with double rod
- Built-in safety check and pressure relief valves
- Requires drain port to be independently connected to the oil tank to avoid back pressure

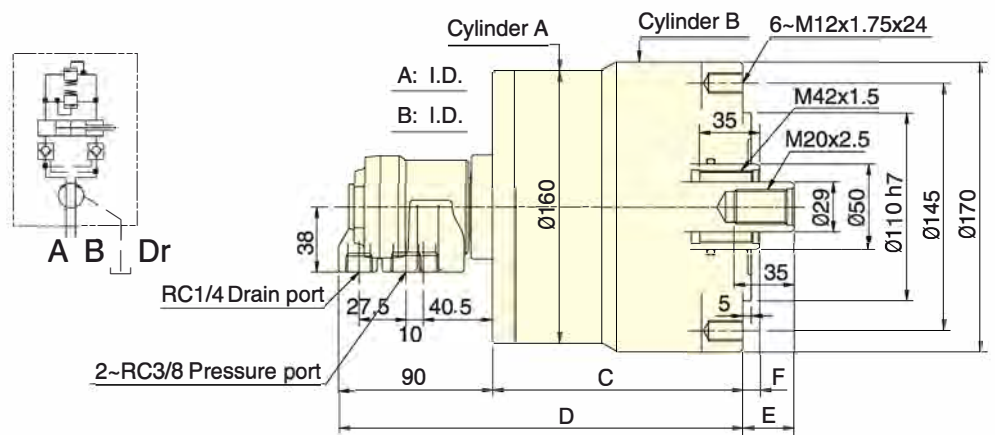
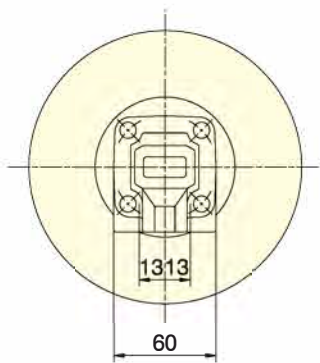

### Specifications

Model	Eff. piston area cm <sup>2</sup>				Piston stroke (Dia.) (mm)	Max. speed min <sup>-1</sup> (r.p.m.)	Max. pressure MPa (kgf/cm <sup>2</sup> )	I kg·m <sup>2</sup> Moment of inertia	Weight (kg)
	Extend		Retract						
	A	B	A	B					
RD-120	122.7	126.1	116.1	113.1	20	5000	3.0(30)	0.14	11.3
RD-125	122.7	126.1	116.1	113.1	25	5000	3.0(30)	0.15	11.5

### Dimensions

Model	A	B	C	D	E		F	
					Max.	Min.	Max.	Min.
RD-120	130	125	137	227	60	40	35	15
RD-125	130	125	147	237	55	30	35	10







### Application/customer benefits

- Rotary valve and cylinder body are made of a special light weight alloy.
- Good option for gear machines
- Unique design allows lubrication of the bearing in the rotary valve allowing for higher speeds and longer life
- Requires drain port to be independently connected to the oil tank to avoid back pressure

### RG-95N

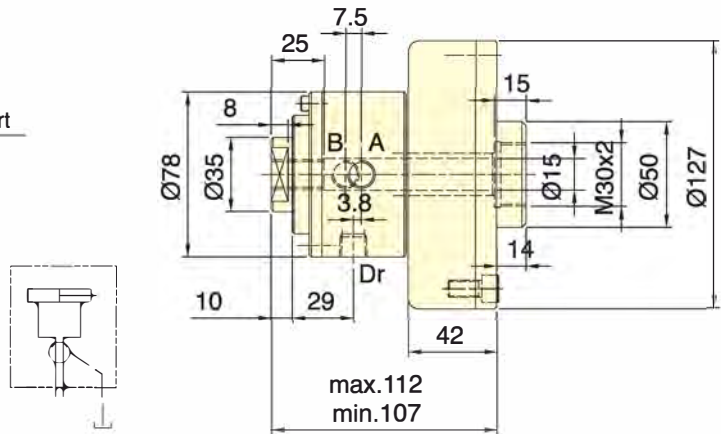
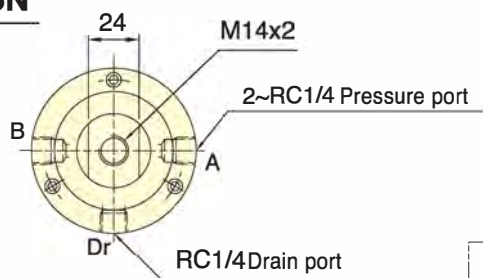

### RG-180N RG-250N

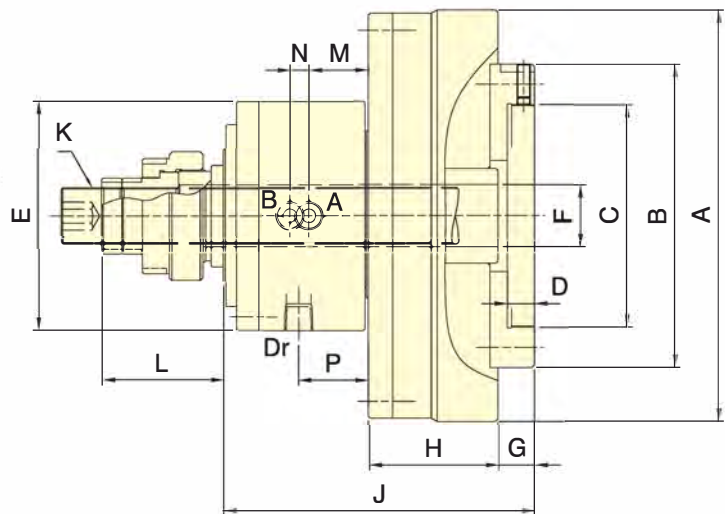
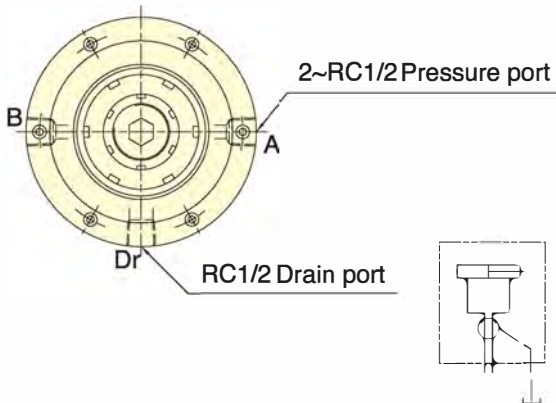

### Specifications

Model	Eff. piston area cm <sup>2</sup>		Piston stroke (Dia.) (mm)	Max. speed min <sup>-1</sup> (r.p.m.)	Max. pressure MPa (kgf/cm <sup>2</sup> )	I kg.m <sup>2</sup> Moment of inertia	Weight(kg)
	Extend	Retract					
RG-95N	59.5	67.7	5	3500	2.0 (20)	0.01	4.7
RG-180N	233.2	237	12	2000	3.5 (35)	0.16	20
RG-250N	444.4	450.1	12	1200	3.5 (35)	0.38	46

### Dimensions

Model	A	B	C	D	E	F	G	H	J	K	L max	L min	M	N	P
RG-180N	205	155	M115x2	18	136	30	25	86.5	205	M27x1.5	56	44	38	11.5	44
RG-250N	305	205	M165x2	20	170	46	27	96	231	M42x1.5	62	50	44.5	14	51.5



### Application/customer benefits

- Used for clamping the cylinder on a rotary table
- Unique design eliminates oil leaks
- I Type - Single circuit clamping
- II Type - Double circuit clamping
- Requires drain port to be independently connected to the oil tank to avoid back pressure

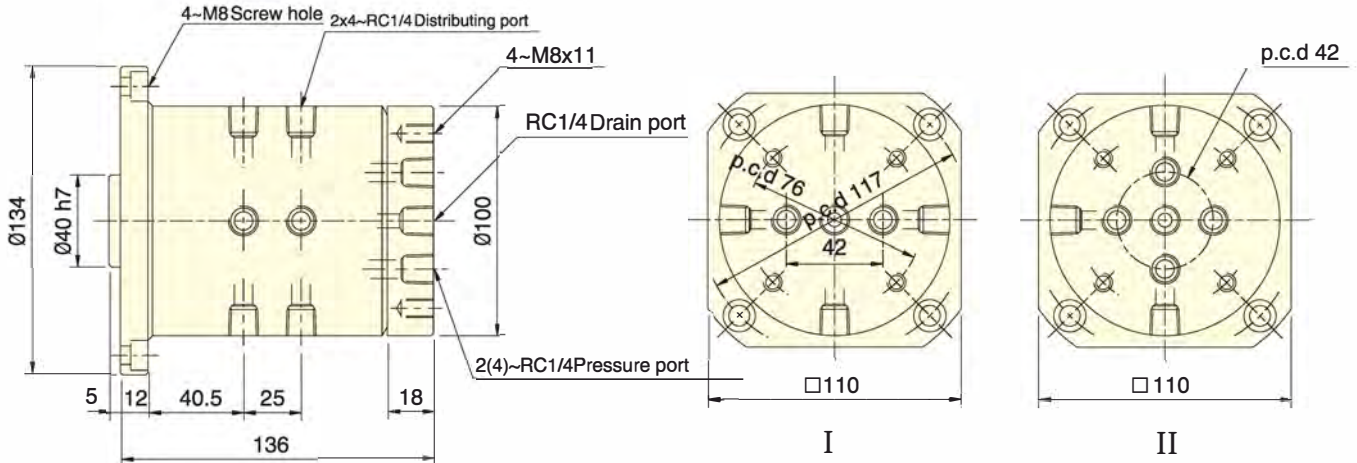

### Specifications

Model	Distributing	Max. pressure (kgf/cm <sup>2</sup> )	Weight
RV-31H	4 (by order)	40 kgf/cm <sup>2</sup> (4.0MPa)	7.4 kgs



### Specifications

Model	Distributing	Max. pressure (kgf/cm <sup>2</sup> )	Weight
RV-A31H	4 (by order)	8 kgf/cm <sup>2</sup> (0.8MPa)	4.8 kgs

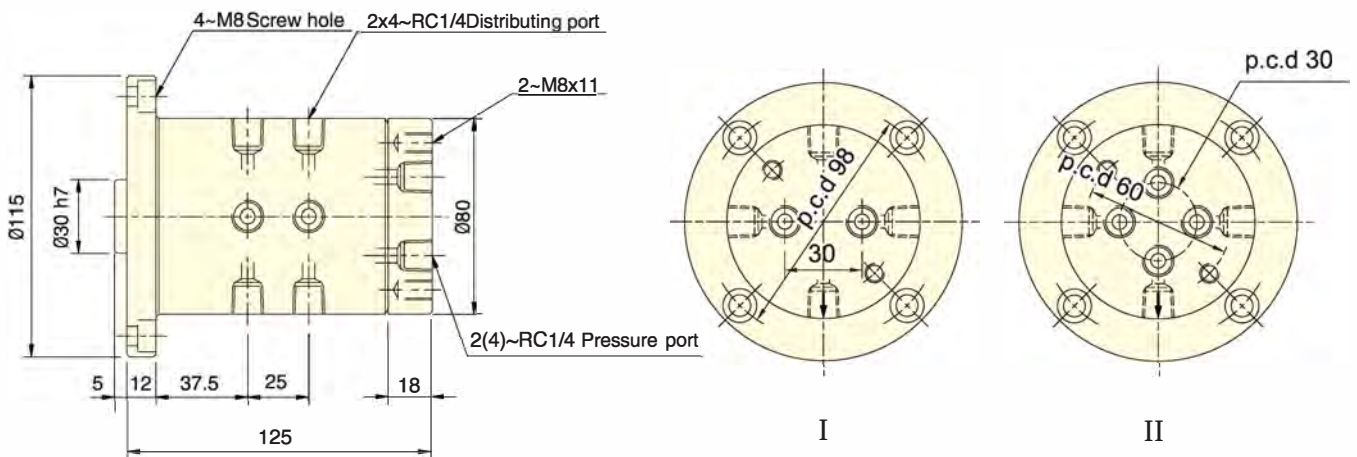



#### Application/customer benefits

- Coolant joint for high speed, high pressure and medium delivery
- Can be used with oil or water soluble coolant
- Interior sealed bushing is made of cemented carbide and ceramics for higher wear-resistance
- Requires liquid through coolant port

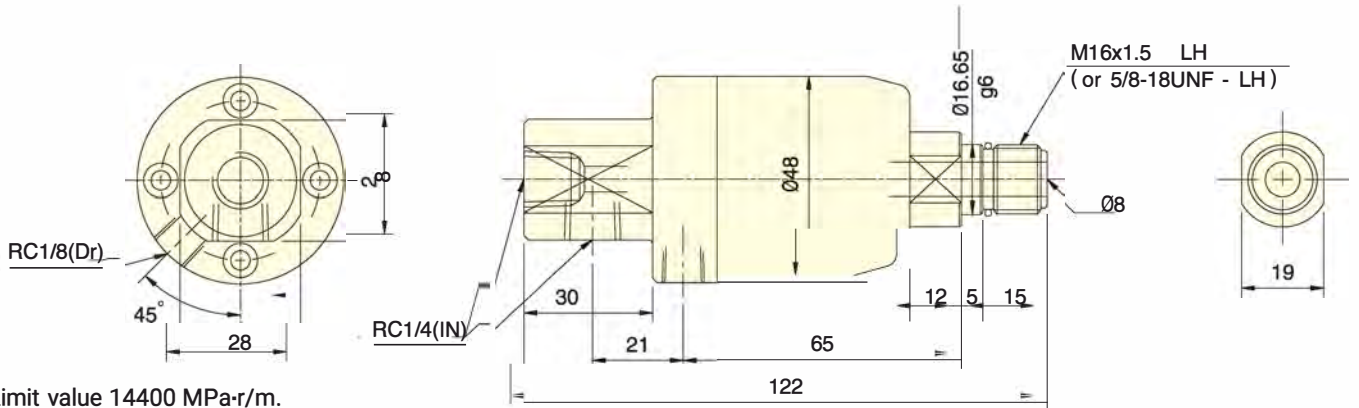

PV Limit value 14400 MPa·r/m.

#### Specifications

Model	P Max. pressure	Delivery amount	V Max. speed	Weight
RJ-80	60 kgf/cm <sup>2</sup> (6.0MPa)	28 l/min(at 50 kgf/cm <sup>2</sup> )	8000 r.p.m.	0.5kgs



#### Application/customer benefits

- Coolant joint for high speed, high pressure and medium delivery
- Can be used with oil or water soluble coolant
- Interior sealed bushing is made of cemented carbide and ceramics for higher wear-resistance
- Seal disconnects automatically if flow stops eliminating potential damage
- Min. pressure is 4kgf/cm<sup>2</sup>

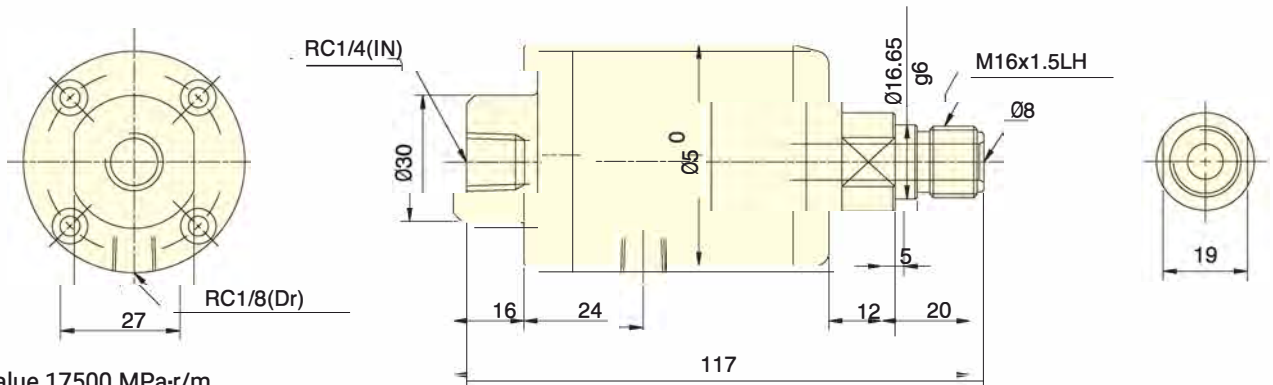

PV Limit value 17500 MPa·r/m.

#### Specifications

Model	P Max. pressure	V Max. speed	Delivery amount	P min. pressure	Weight
RJ-90	70 kgf/cm <sup>2</sup> (7.0MPa)	10000 r.p.m.	28 l/min(at 50 kgf/cm <sup>2</sup> )	4 kgf/cm <sup>2</sup> (0.4MPa)	0.5 kgs



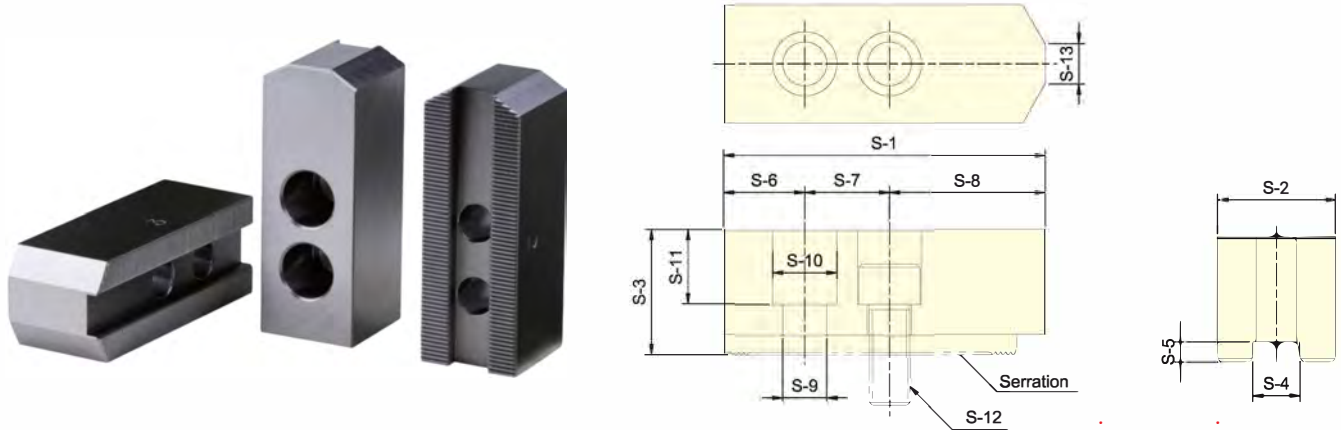

### Dimensions

Model	S-1	S-2	S-3	S-4	S-5	S-6	S-7	S-8	S-9	S-10	S-11	S-12	S-13	Serration Pitch	Matching Chuck	3 Jaw Weight (kg)
SJ04	52	23	23	10	5	10	14	28	9	14	13	M8	3	1.5x60°	3H-04, 3P-04	0.5
SJ05	62	25	30	10	5	10	14	38	9	14	18	M8	3.5	1.5x60°	3H-05, 3L-205, 3P-05, 3M-05	0.8
SJ06	73	31	36	12	5	15	20	38	11	17	24	M10	14	1.5x60°	3H-06, 3L-206, 3P-06, 3M-06	1.5
SJ08	95	35	37	14	5	24	25	46	13	19	22	M12	16	1.5x60°	3H-08, 3L-208, 3P-08, 3M-08	2.4
SJ10	110	40	42	16	5	30	30	50	13	19	27	M12	18	1.5x60°	3H-10, 3L-210, 3P-10, 3M-10	3.7
SJ12H	130	50	50	21	5	40	30	60	18	26	33	M16	23	1.5x60°	3H-12, 3L-212, 3V-12, 3P-12, 3M-12	6.3
SJ12P	130	50	50	18	5	40	30	60	16	23	33	M14	23	1.5x60°	3P-12	6.5
SJ15H	165	62	62	22	8	37	43	85	21	32	38	M20	-	1.5x60°	3H-15, 3H-18	12.6
SJ15P	165	62	62	25.5	8	37	43	85	21	32	38	M20	-	1.5x60°	3H-15, 3H-18, 3L-15, 3P-15, 3P-18, 3V-15, 3V-18	12.5
SJ21	180	65	70	25	9	40	60	80	21	32	45	M20	-	3.0x60°	3H-21, 3H-24, 3P-21, 3P-24, 3V-21, 3V-24, 3V-32	15.8

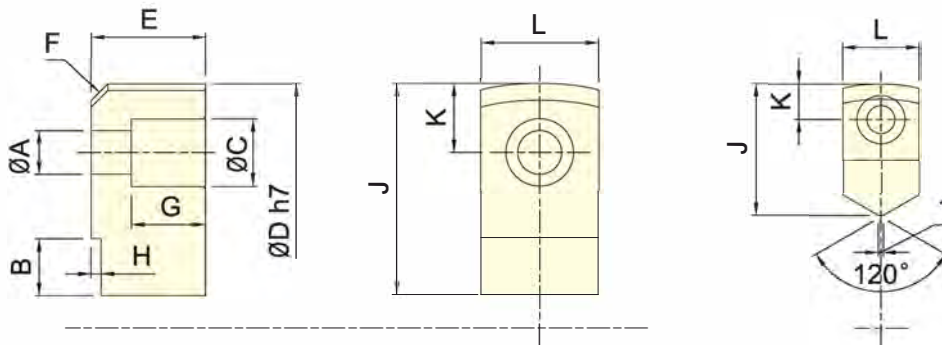

for 3U-203

### Dimensions

Model	A	B	C	D	E	F	G	H	J	K	L
3U-203	5.5	11	9.5	66	12	C3	7	3	26	7	15
3U-204	6.6	11	11	84	17	C4	11	3	32	9.5	20
3U-205	9	13.5	14	108	20	C4	12	3	41.5	13	24
3U-206	11	15	17	129	30	C6	20	3	50	17	30
3U-208	13	17	20	156	34	C6	22	3	63	20.5	35
3U-210	15	20	22	187	39	C6	24	4	74	23	40
3U-212	15	18	22	234	44	C6	29	4	72	23	40

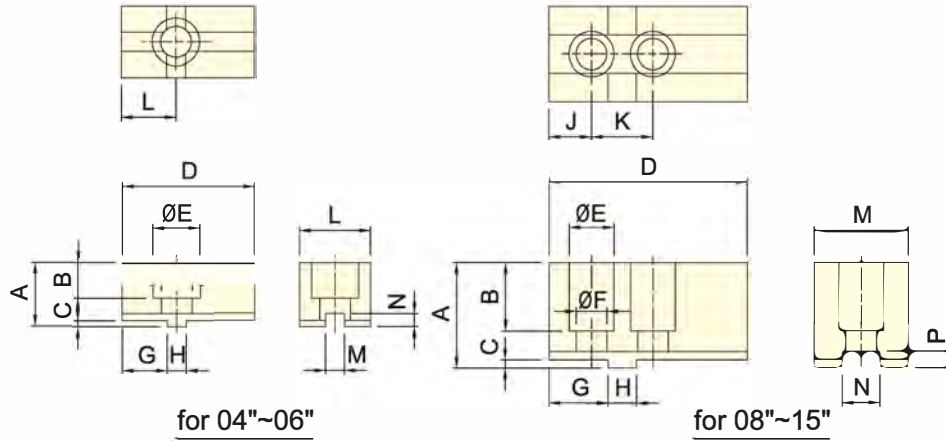

Dimensions

Model	A	B	C	D	E	F	G	H	J	K	L	M	N	P
3D-04	19.5	13	2.5	52	17.5	11	18	8	-	-	22	25	8	5.5
3D-05	27	15	2.5	56	20	13	19	8	-	-	23	30	8	5.5
3D-06	34	21	3	70	23	15.5	22	10	-	-	27	40	10	6
3D-08	44.5	29	3.5	84	19	13	25	12	18	26	-	40	16	7
3D-10	49.5	32	3.5	100	22	15	30.5	15	22	32	-	50	18	7
3D-12	54.5	36	3.5	120	26	18	33.5	17	24	36	-	60	20	7
3D-15	60	40	5	165	26	18	50	20	40	40	-	70	24	10

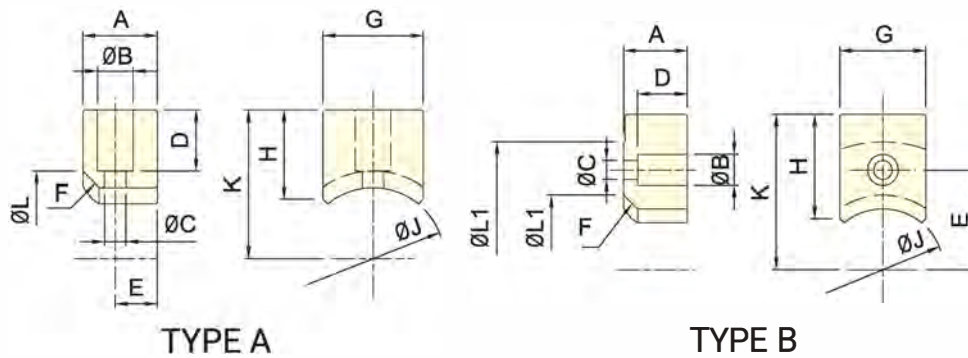

Dimensions

Model	A	B	C	D	E	F	G	H	J	K	L	L1	
3E-05	TYPE A	20	11	6.6	16.5	10	C5	25	22	29	34.5	39	-
	TYPE B	20	11	6.6	15	25.5	C5	25	30	29	42.5	39	69
3E-06	TYPE A	23	11	6.6	19	13	C5	31	27.5	44	46	54	-
	TYPE B	23	11	6.6	18	36	C5	31	37.5	44	56	54	92
3E-08	TYPE A	30	14	9	25	15	C6	35	36	50	56	62	-
	TYPE B	30	14	9	24	41	C6	35	56	50	76	62	112
3E-10	TYPE A	35	17.5	11	26.5	17.5	C5	40	40	60	64.5	70	-
	TYPE B	35	17.5	11	26	47.5	C5	40	71.5	60	96	70	129

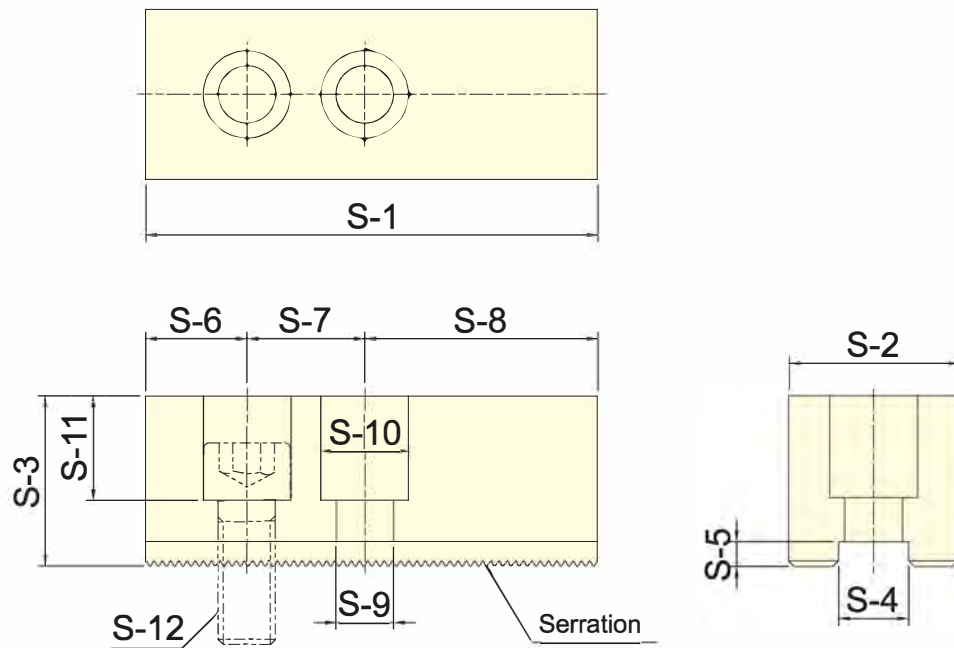

**Dimensions**

Model	S-1	S-2	S-3	S-4	S-5	S-6	S-7	S-8	S-9	S-10	S-11	S-12	Serration Pitch	Matching Chuck	3 Jaw Weight (kg)
SJ-145	165	62	62	25.5	9	37	43	85	21	32	38	M20	3.0×60°	AP-145, AP-185	12.2
SJ-185	165	62	62	25.5	9	37	43	85	21	32	38	M20	3.0×60°	AP-145, AP-185	12.2
SJ-230	180	64	70	25.5	9	40	60	80	21	32	45	M20	3.0×60°	AP-230, AP-275	16.1
SJ-275	180	64	70	25.5	9	40	60	80	21	32	45	M20	3.0×60°	AP-230, AP-275	16.1
SJ-320	210	75	80	30	9	40	60	110	26	38	55	M24	3.0×60°	AP-320, AP-375	24.7



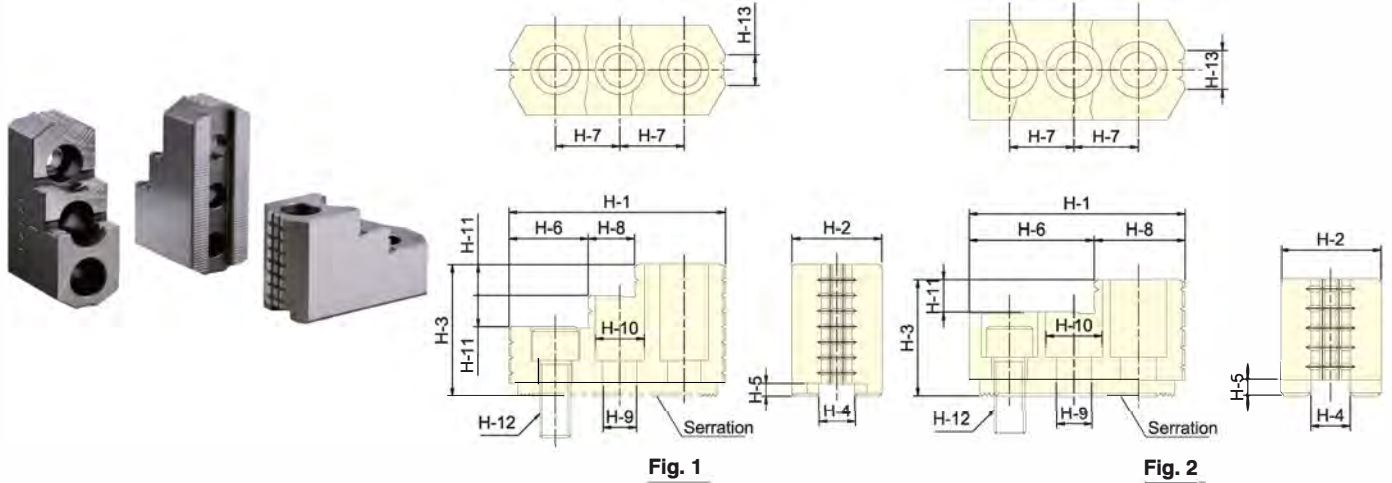

### Dimensions

Model	H-1	H-2	H-3	H-4	H-5	H-6	H-7	H-8	H-9	H-10	H-11	H-12	H-13	Serration Pitch	Matching Chuck	3 Jaw Weight (kg)	Reference Drawing
HJ05	53	23	27.5	10	4	30.5	14	22.5	8.5	13.5	10	M8	6	1.5×60°	3H-04, 3H-05	1.0	Fig.2
HJ06	67	31	35	12	5	39	20	28	11	17	12	M10	10	1.5×60°	3H-06, 3P-06	1.7	Fig.2
HJ08	86	35	51	14	5	31	25	18	13	19	12	M12	12	1.5×60°	3H-08, 3P-08	2.0	Fig.1
HJ10	99.5	40	54	16	5	43	30	17	13	19	13	M12	15	1.5×60°	3H-10, 3P-10	3.0	Fig.1
HJ12H	103	50	52	21	5	62.5	30	40.5	17	25	17	M16	30	1.5×60°	3H-12, 3P-12	3.5	Fig.2
HJ12P	103	50	52	18	5	62.5	30	40.5	15	22	17	M14	30	1.5×60°	3P-12	3.6	Fig.2
HJ15H	149	62	86	22	8	63	43	34	21	32	20	M20	43	1.5×60°	3H-15, 3H-18	9.6	Fig.1
HJ15P	149	62	86	25.5	6	63	43	34	21	32	20	M20	43	1.5×60°	3H-15, 3H-18, 3P-15, 3P-18	9.5	Fig.1
HJ21	159.5	80	90	25	9	104.5	50	55	21	32	40	M20	55	3.0×60°	3H-21, 3H-24, 3P-21, 3P-24, 3V-32	14.3	Fig.2

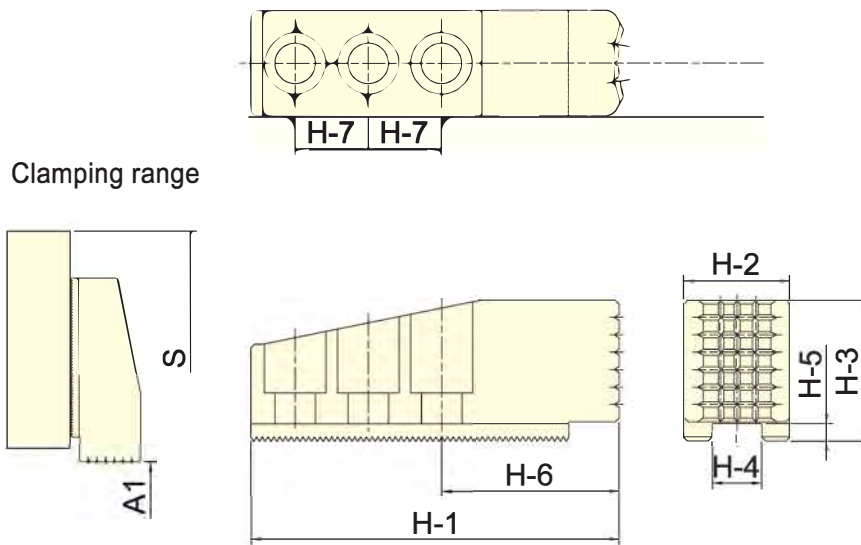

### Dimensions

Model	H-1	H-2	H-3	H-4	H-5	H-6	H-7	A1	S	Serration Pitch	Matching Chuck	3 Jaw Weight (kg)
HJ-145	191	55	73	25.5	9	92	38	28-120	420	3.0×60°	AP-145	12.5
HJ-145	191	55	73	25.5	9	92	38	28-155	460	3.0×60°	AP-185	12.5
HJ-145	191	55	73	25.5	9	92	38	60-235	535	3.0×60°	AP-230	12.5
HJ-145	191	55	73	25.5	9	92	38	105-280	580	3.0×60°	AP275	12.5
HJ-320	243	75	82	30	9	110	50	100-295	658	3.0×60°	AP-320	24.6
HJ-320	243	75	82	30	9	110	50	175-375	738	3.0×60°	AP-375	24.6

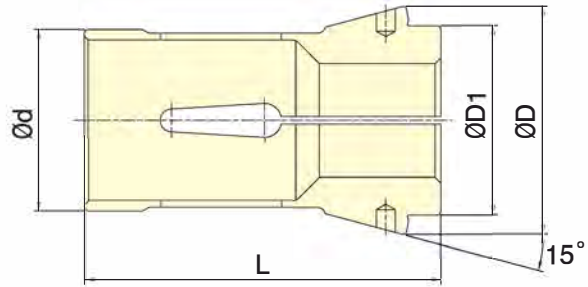

DIN 6343 Collet standard

### Specifications

Collet	Max. Chucking Capacity mm			d	D	D1	L	Matching Collet Chuck
	Round	Hexagom	Square					
161E	3~26	4~22	4~18	32	45	34	75	CL-26, CL-26A4
163E	3~30	4~26	4~20	35	48	38	80	CL-30, CL-30A4
171E	3~36	6~32	6~26	42	55	42	94	CL-36, CL-36A5
173E	3~42	6~36	6~29	48	60	50	94	CL-42, CL-42A5, CL-42A6
177E	5~52	8~45	7~36	58	70	60	94	CL52, CL-52A6
185E	5~60	8~52	7~42	66	84	73	110	CL6017, CL-6022, CL-60A6, CL-60A8
193E	20~80	18~69	15~56	90	107	92	130	CL-80, CL-80A8

### Dimensions

Test Bar D(S,H)	L mm	A DIN	
		Class1	Class2
0.5~1.0	3	0.015	0.015
1.0~1.6	6	0.015	0.020
1.6~3.0	10	0.015	0.020
3.0~6.0	16	0.015	0.020
6.0~10	25	0.015	0.020
10.0~18.0	40	0.020	0.030
18.0~24.0	50	0.020	0.030
24.0~30.0	60	0.020	0.030
30.0~50.0	80	0.030	0.040
50.0~60.0	100	0.030	0.040

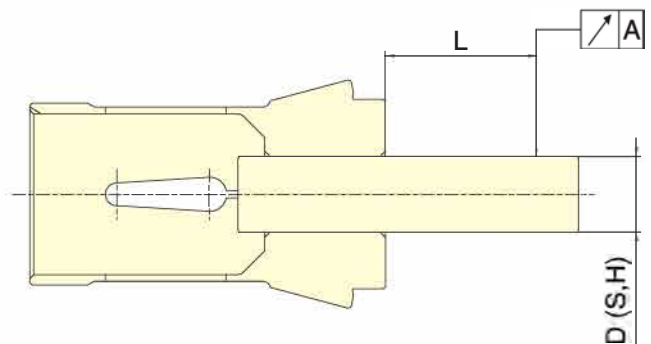

Note : Collets chuck are conformed to DIN6343 Class2.

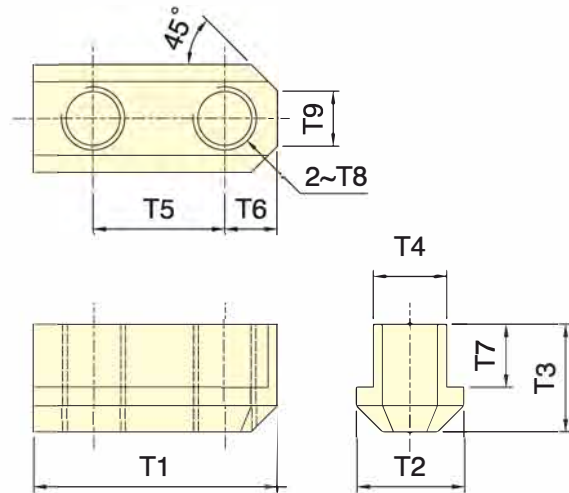

TN1

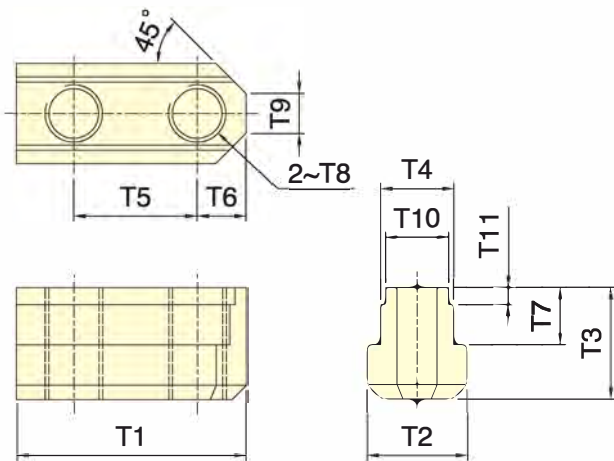

TN2

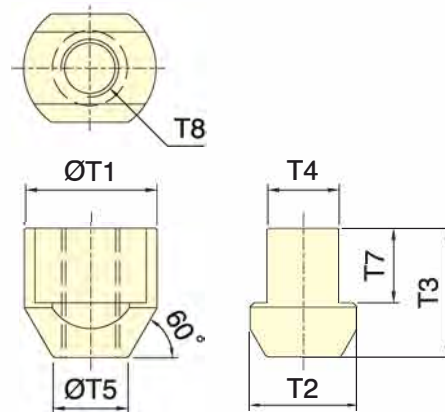

TN3

Specifications

Model	T1	T2	T3	T4	T5	T6	T7	T8	T9	T10	T11	Matching Chuck	3 Jaw Weight (kg)
TN1-04	26	15	15	10	14	6	9.5	M8	5	-	-	3H-04, 2H-04, 3H-05, 2H-05, 3L-205, 2L-205, 3P-04, 2P-04, 3P-05, 2P-05, 3M-05, 2M-05	0.06
TN1-06	36	17.5	18.5	12	20	8	11	M10	6	-	-	3H-06, 2H-06, 4H-06, 3H-206, 3L-206, 2L-206, 3P-06, 2P-06, 3M-06, 2M-06	0.15
TN1-08	46.5	20	20.5	14	25	10.5	12	M12	10	-	-	3H-08, 2H-08, 4H-08, 3H-208, 3L-208, 2L-208, 3P-08, 2P-08, 3M-08, 2M-08, 4T-08	0.27
TN1-10	51	22.5	21.5	16	30	11	13	M12	11	-	-	3H-10, 2H-10, 4H-10, 3H-10B, 3L-210, 2L-210, 3P-10, 2P-10, 3M-10, 2M-10, 4T-10, 4T-12	0.36
TN1-12	55.5	29.5	23.5	21	30	12	12	M16	13	-	-	3H-12, 2H-12, 4H-12, 3H-12B, 3L-212, 2L-212, 3M-12, 2M-12	0.63
TN2-12	55.5	29.5	28	21	30	12	16.5	M14	13	18	4.5	3P-12, 2P-12, 3V-12, 4T-15	0.63
TN1-15	80	35	39	25.5	43	17	20	M20	14	-	-	3H-15, 2H-15, 4H-15, 3H-15B, 3H-18, 4H-18, 3H-18B, 3L-15, 2L-15, 3P-15, 2P-15, 3P-18, 3V-15, 3V-18	1.53
TN2-15	80	35	39	25.5	43	17	20	M20	14	22	6	3H-15, 2H-15, 4H-15, 3H-15B, 3H-18, 4H-18, 3H-18B, 3L-15, 2L-15, 3P-15, 2P-15, 3P-18, 3V-15, 3V-18	1.5
TN3-21	46	37.5	45	25	26.5	-	26	M20	-	-	-	3H-21B, 3H-24B, 3P-21, 3P-24, 3V-21, 3V-24, 3V-32	1.84



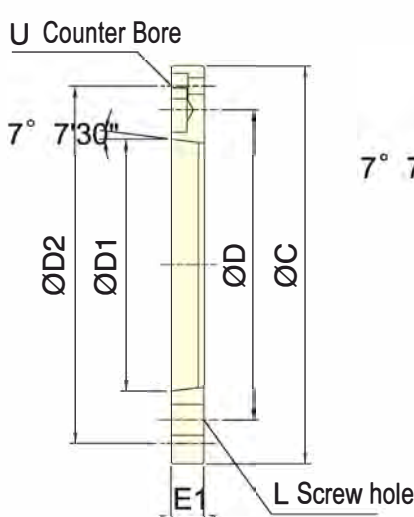

**FL 1**

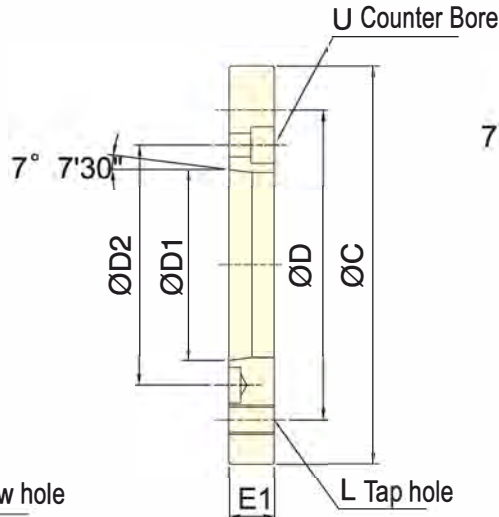

**FL 2**

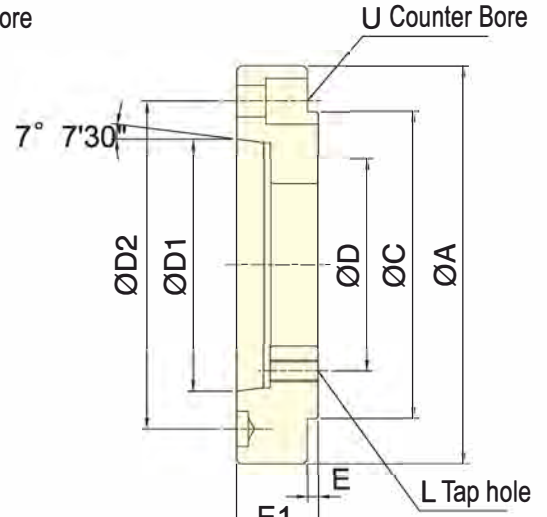

**FL 3**

**Specifications**

Model	A	C	D	D1	D2	E	E1	L	U	Remark	Weight (kg)
FL3-04A <sub>2</sub> 4	110	85	70.6	63.513	82.6	8	28	M10	M10	3H-04, 2H-04	1.12
FL3-04A <sub>2</sub> 5	140	85	70.6	82.563	104.8	5.5	32	M10	M10	3H-04, 2H-04	2.28
FL1-05A <sub>2</sub> 4	-	110	82.6	63.513	96	-	15	M10	M6	3H-05, 2H-05, 3L-05, 2L-05	0.65
FL3-05A <sub>2</sub> 5	135	110	82.6	82.563	104.8	6	30	M10	M10	3H-05, 2H-05, 3L-05, 2L-05	1.99
FL1-06A <sub>2</sub> 5	-	140	104.8	82.563	116	-	15 *18	M10	M6	3H-06, 2H-06, 4H-06, 3H-206, *3L-206, *2L-206, 3P-06, 2P-06, 3M-06, 2M-06	0.96
FL3-06A <sub>2</sub> 6	165	140	104.8	106.375	133.4	6	35	M10	M12	3H-06, 2H-06, 4H-06, 3H-206, 3L-206, 2L-206, 3P-06, 2P-06, 3M-06, 2M-06	3.12
FL2-08A <sub>2</sub> 5	-	170	133.4	82.563	104.8	-	23	M12	M10	3H-08, 2H-08, 4H-08, 3L-208, 2L-208, 3P-08, 2P-08, 3M-08, 2M-08, 4T-08	2.70
FL1-08A <sub>2</sub> 6	-	170	133.4	106.375	150	-	17 *23	M12	M6	3H-08, 2H-08, 4H-08, 3H-208, *3L-208, *2L-208, 3P-08, 2P-08, 3M-08, 2M-08, 4T-08	1.55
FL2-10A <sub>2</sub> 6	-	220	171.4	106.375	133.4	-	25	M16	M12	3H-10, 2H-10, 4H-10, 3L-210, 2L-210, 3P-10, 2P-10, 3M-10, 2M-10, 3H-12, 2H-12, 4H-12, 3L-212, 2L-12, 3P-12, 2P-12, 3M-12, 2M-12, 4T-10, 4T-12	5.02
FL1-10A <sub>2</sub> 8	-	220	171.4	139.719	190	-	18	M16	M8	3H-10, 2H-10, 4H-10, 3H-10B, 3L-210, 2L-210, 3P-10, 2P-10, 3M-10, 2M-10, 3H-12, 2H-12, 4H-12, 3L-212, 2L-12, 3P-12, 2P-12, 3M-12, 2M-12, 4T-10, 4T-12	2.73
FL2-15A <sub>2</sub> 8	-	300	235	139.719	171.4	-	33	M20	M16	3H-15, 2H-15, 4H-15, 3L-15, 2L-15, 3P-15, 2P-15, 3M-15, 2M-15, 4T-15, 3H-18, 4H-18, 3P-18	12.52
FL1-15A <sub>2</sub> 11	-	300	235	196.869	260	-	22	M20	M10	3H-12B, 3H-15, 2H-15, 4H-15, 3L-15, 2L-15, 3P-15, 2P-15, 3M-15, 2M-15, 4T-15, 3H-18, 4H-18, 3P-18	6.03
FL2-21A <sub>2</sub> 8	-	380	330.2	139.719	171.4	-	27	M24	M16	3P-21, 4P-21, 3P-24, 4P-24	22.05
FL2-21A <sub>2</sub> 11	-	380	330.2	196.869	235	-	27	M24	M20	3P-21, 4P-21, 3P-24, 4P-24	16.28
FL1-21A <sub>2</sub> 15	-	380	330.2	285.775	330.2	-	27	M24	M12	3H-15B, 3H-18B, 3H-21B, 3P-21, 4P-21, 3P-24, 4P-24	8.60
FL2-40A <sub>2</sub> 15	-	520	463.6	285.775	330.2	-	40	M24	M24	3H-24B	43.26
FL1-40A <sub>2</sub> 20	-	520	463.6	412.775	463.6	-	27	M24	M12	3H-24B	13.55



■ The proximity switch is optional.

Model	Power supply	Switching cap.	Output type
IA12DLF02N03219 (CARLO)	DC 10/30V	200mA	NPN

■ Terminal Connections

Model	IA12DLF02N03219 (CARLO)
OP2	BLACK
+V	BROWN
OV	BLUE
OP1	BLACK

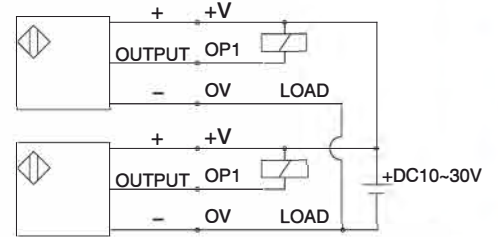

**CT**

**CT-S**

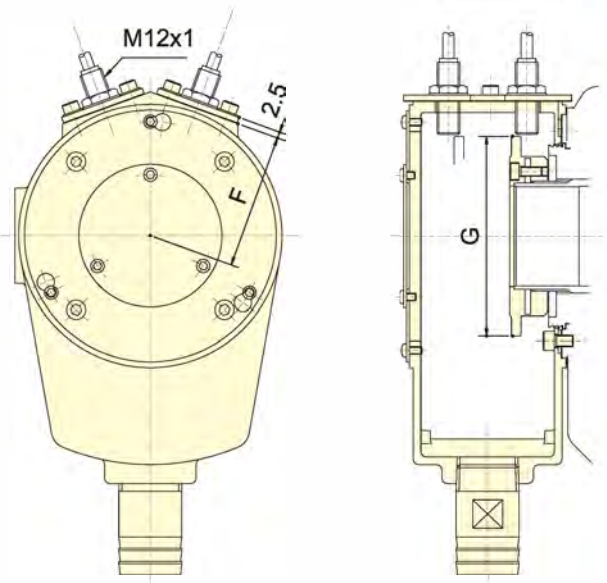
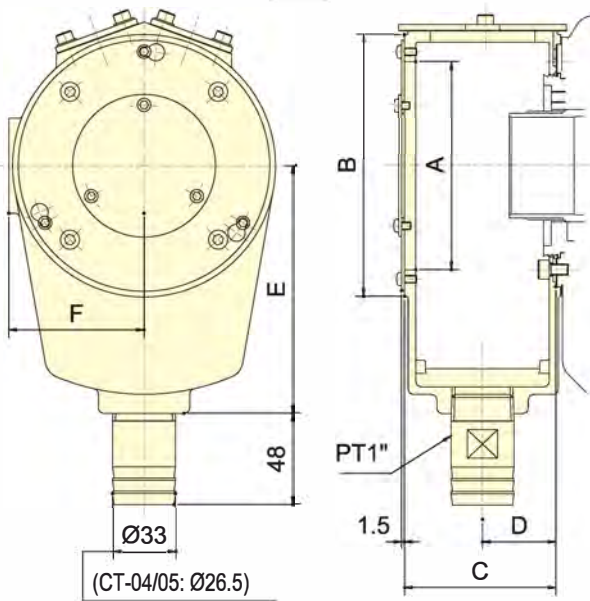

Coolant Collector

Coolant Collector with Detecting Ring

■ Specifications

Model	A	B	C	D	E	F	G	Weight (kg)		Matching cyl.
								CT	CT-S	
CT-04/CT-04S	87	110	60	29	110	57	79	0.9	1.1	TH-A428
CT-05/CT-05S	87	110	60	29	110	57	84	0.9	1.1	TH-A536, TK-A528, TK-A533
CT-06/CT-06S	100	125	74	36	120	64.5	94	1.2	1.6	TK-C643,TK-A646,TK-B646, TK-C646,TK-646A
CT-08/CT-08S	110	138	80	39	130	71	105	1.3	1.8	TK-B846, TK-A853, TK-B853
CT-K10/CT-K10S	158	185	88	43	160	94.5	145	1.9	2.6	TK-1068, TK-1075
CT-K10/CT-K1078S	158	185	88	43	160	94.5	145	1.9	2.6	TK-1078
CT-12/CT-12S	158	185	88	43	160	94.5	145	1.9	2.6	TK-1287, TK-A1291
CT-15/CT-15S	206	235	100	50	210	121	196	3.1	4.3	TK-1511, TK-1512
CT-21/CT-21S	226	255	100	50	210	131	210	3.3	4.6	TK-2114
CT-24/CT-24S	250	270	100	50	230	154	248	3.5	5.5	TK-2416, TK-2416L
CT-28/CT-28S	310	330	100	50	260	181	305	4.3	7.2	TK-2820

# FV-01

## STATIONARY CYLINDER LOCK VALVE FOR AIR STATIONARY CHUCK

Accessories

PARTS AND ACCESSORIES

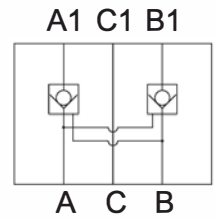
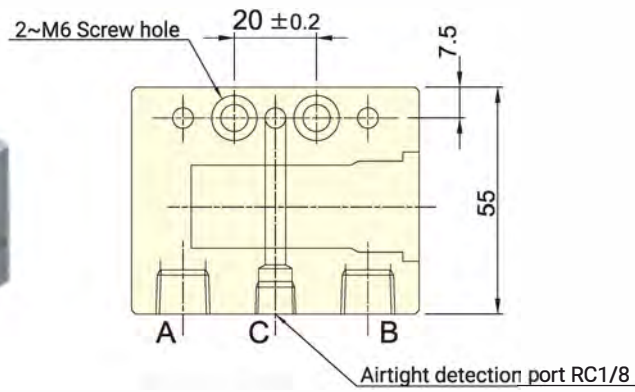

Circuit drawing

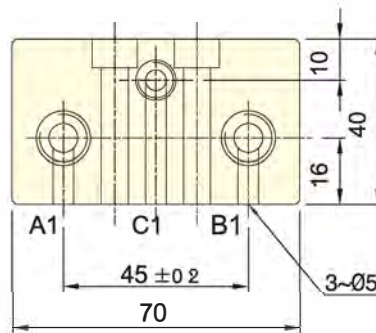

# VH-201

## HAND OPERATED AIR VALVE

Accessories



### Dimensions

Max. pressure	1MPa(10 kgf/cm <sup>2</sup> )
Operating angle	90°
Port size	Rc1/4

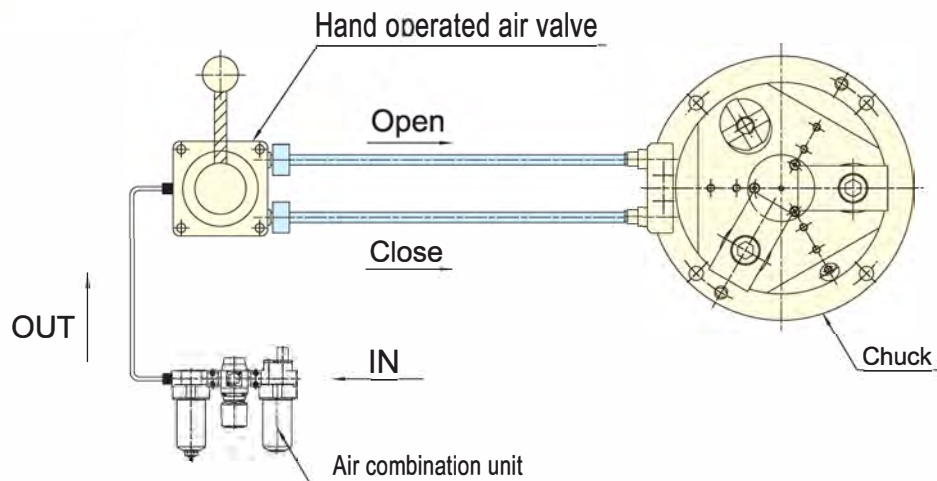

Assembly drawing



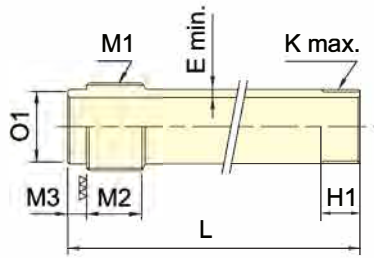

**Detail of Draw Pipe**  
 $L=A+G2max.+H-G1max.+M2+M3$

3H-04 can work with TH-428.

Note: To calculate the draw-bar length of 2H, 4H as 3H.

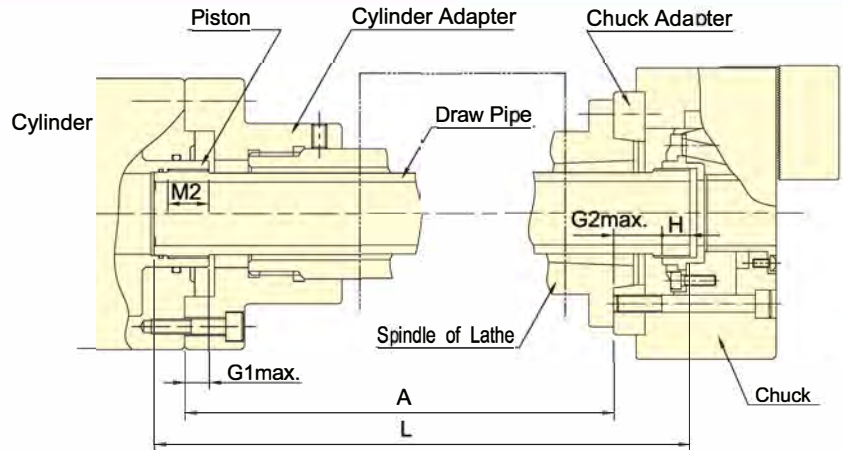

Chuck type	Cylinder type	G1 max.	H	M3	M2	G2 max.	M1	H1	O1(f7)	K max.	E min.	L
3H-04A4	TK-A533	12	14.5	13	25	31.5	M38x1.5	25	35 -0.025 -0.050	M32x1.5	3.5	A+59+13
3H-05A4	TK-A533	12	17	13	25	16	M38x1.5	25	35 -0.025 -0.050	M40x1.5	3.5	A+46+13
3H-06A5	TK-C646	15	15	13	25	26	M55x2	25	50 -0.025 -0.050	M55x2	5	A+52+13
3H-08A6	TK-A853	20	16.5	15	30	31.5	M60x2	25	55 -0.030 -0.060	M60x2	5	A+58+15
3H-10A6	TK-1075	25	20.5	15	35	33.5	M85x2	30	80 -0.030 -0.060	M85x2	5	A+64+15
3H-10A8	TK-1075	25	20.5	15	35	26.5	M85x2	30	80 -0.030 -0.060	M85x2	5	A+57+15
3H-12A6	TK-A1291	30	23	15	35	33	M100x2	35	95 -0.036 -0.071	M100x2	5	A+61+15
3H-12A8	TK-A1291	30	23	15	35	26	M100x2	35	95 -0.036 -0.071	M100x2	5	A+54+15
3H-15A8	TK-1512	30	33	15	45	44	M130x2	45	125 -0.043 -0.083	M130x2	5	A+92+15
3H-15A11	TK-1512	30	33	15	45	33	M130x2	45	125 -0.043 -0.083	M130x2	5	A+81+15
3H-18A11	TK-1512	30	33	15	45	33	M130x2	45	125 -0.043 -0.083	M130x2	5	A+81+15

Chuck type	Cylinder type	G1 max.	H	M3	M2	G2 max.	M1	H1	O1(f7)	K max.	E min.	L
3H-204A5	TK-A528	12	17.5	10	25	18.5	M38x1.5	25	35 -0.025 -0.050	M40x1.5	5	A+49+12
3H-205A5	TK-A528	12	17	10	25	16	M38x1.5	25	35 -0.025 -0.050	M45x1.5	5	A+46+13
3H-206A5	TK-A853	20	14	12	30	28	M60x2	25	55 -0.030 -0.060	M60x2	5	A+52+13
3H-208A6	TK-1068	25	16.5	12	35	33.5	M75x2	25	70 -0.030 -0.060	M75x2	5	A+55+12
3H-10BA8	TK-12847	30	20.5	12	35	26.5	M95x2	30	95 -0.036 -0.071	M95x2	5	A+52+12
3H-12BA11	TK-1511	30	23	12	45	30	M120x2	35	125 -0.043 -0.083	M115x2	5	A+68+12
3H-15BA15	TK-2114	35	33	17	45	38	M155x2	45	145 -0.043 -0.083	M155x3	5	A+81+17
3H-18BA15	TK-2416	35	33	17	45	45	M180x3	45	170 -0.043 -0.083	M175x3	5	A+88+17
3H-21BA15	TK-2820	51	33	17	45	38	M220x3	45	210 -0.050 -0.096	M190x3	5	A+65+17
3H-24BA15	TK-2820	51	34	17	45	58	M220x3	45	210 -0.050 -0.096	M215x3	5	A+86+17
3H-24BA20	TK-2820	51	34	17	45	45	M220x3	45	210 -0.050 -0.096	M215x3	5	A+73+17

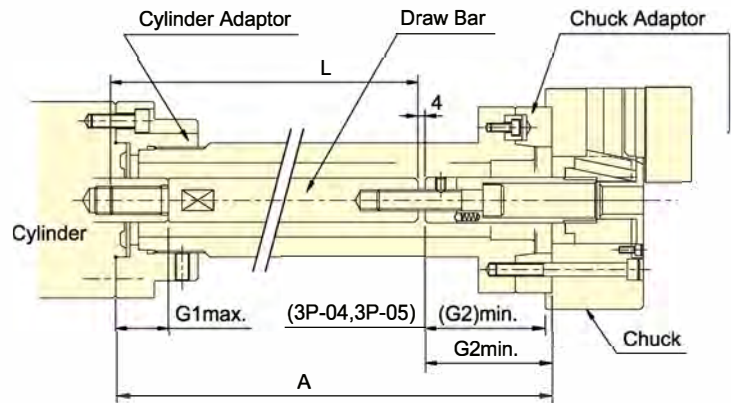
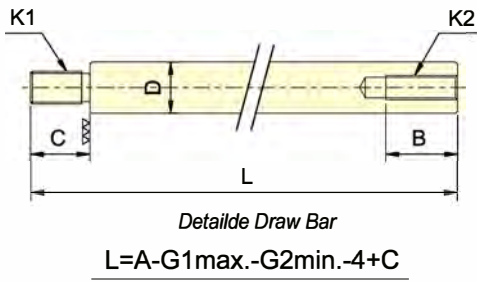

Chuck type	Cylinder type	B	C	D	G1 max.	G2 min.	K1	K2	L
3P-04	RK-75(N)/RA-130	30	30/20	30/25	45	3	M20x2.5/M16x2	M10x1.5	A-22/A-32
3P-05	RK-75(N)/RA-130	40	30/20	30/25	45	-6	M20x2.5/M16x2	M12x1.75	A-13/A-23
3P-06	RK-100(N)/RA-170	40	30/25	30/25	45	81.5	M20x2.5/M16x2	M16x2	A-101/A-106
3P-08	RK-125(N)/RA-220	40	40/30	35/30	50	106	M24x3/M20x2.5	M20x2.5	A-120/A-130
3P-10	RK-125(N)/RA-220	40	40/30	35/30	50	133	M24x3/M20x2.5	M20x2.5	A-147/A-157
3P-12	RK-150(N)/RA-270	40	40/35	45/35	55	133	M30x3.5/M24x3	M20x2.5	A-152/A-157
3P-15	RK-200(N)	60	55	55	70	69	M36x4	M30x3.5	A-88
3P-18	RK-200(N)	60	55	55	70	57	M36x4	M30x3.5	A-76
3P-21	RK-200(N)	60	55	55	70	62	M36x4	M30x3.5	A-81
3P-24	RK-200(N)	60	55	55	70	62	M36x4	M30x3.5	A-81

Note: To calculate the draw-bar length of 2P as 3P.

Chuck type	Cylinder type	B	C	D	G1 max.	G2 min.	K1	K2	L
3M-05	RK-75(N)	40	30	30	45	-2	M20x2.5	M12x1.75	A-17
3M-06	RK-100(N)	40	30	30	45	81.5	M20x2.5	M16x2	A-101
3M-08	RK-125(N)	40	40	35	50	106	M24x3.0	M20x2.5	A-120
3M-10	RK-125(N)	40	40	35	50	135	M24x3.0	M20x2.5	A-148
3M-12	RK-150(N)	50	40	45	55	40	M30x3.5	M24x3	A-59

Note: To calculate the draw-bar length of 2M as 3M.







