



COMPLETE
METALWORKING
SOLUTIONS

(800) 991-4225
www.ahbinc.com
ISO Certified
customerservice@ahbinc.com



blue photon®
Technology & Workholding Systems LLC



2021 Product Catalog

POWERFUL WORKHOLDING

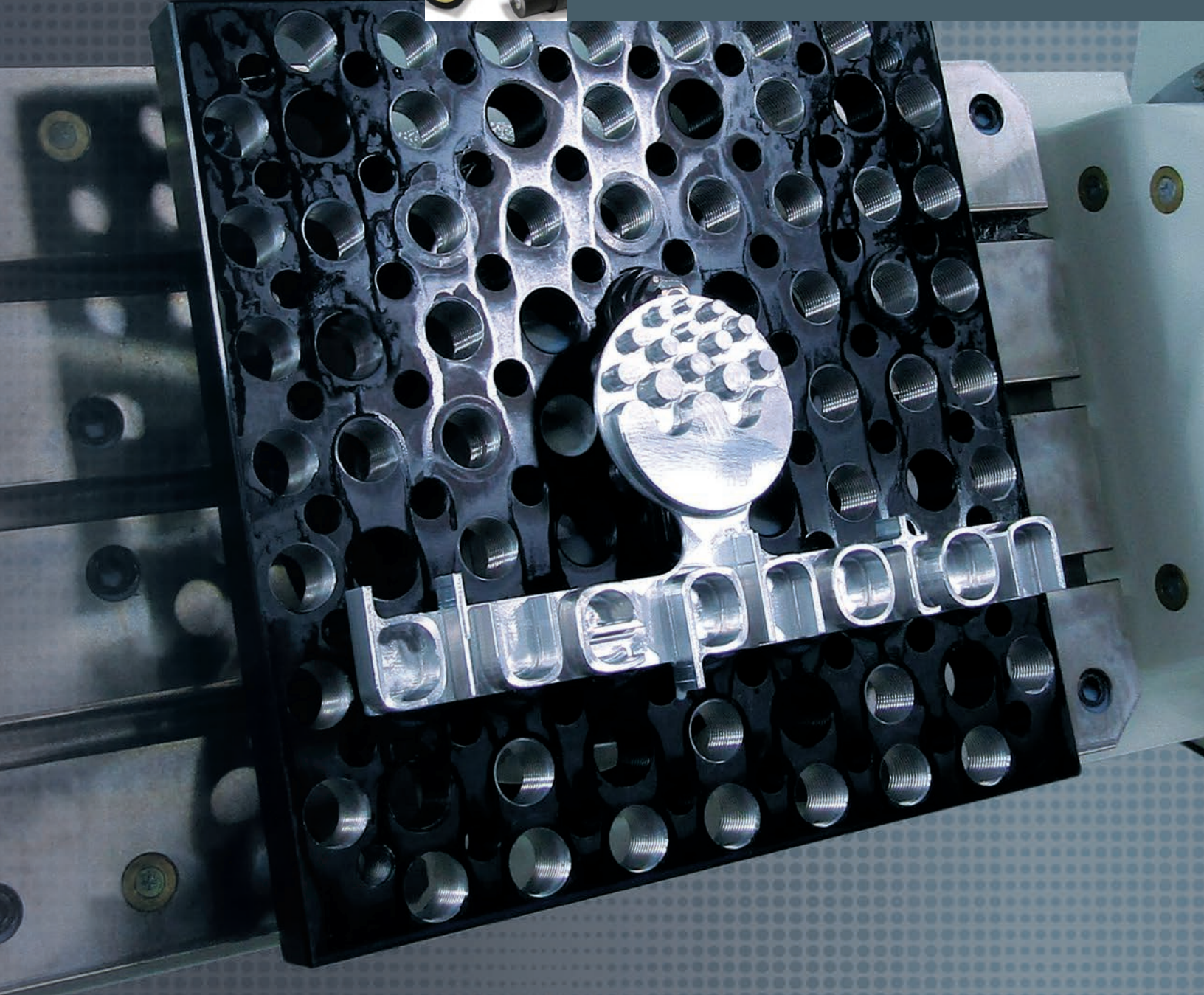



Blue Photon manufactures a patented photo-activated adhesive workholding system. The Blue Photon grip technology solves problems associated with current workholding devices. The technology allows the user to hold parts and most materials without the use of clamps.

Warranty

Blue Photon is proud to offer a 3-year warranty on all Blue Photon grippers. Grippers are warranted against manufacturer's defects when used exclusively with BlueGrip workholding adhesives.

All other Blue Photon equipment is warranted for a period of one year from the date of delivery against manufacturing defects that affect the performance of the Blue Photon system. Equipment and supplies not manufactured by Blue Photon may have different manufacturer warranties.

Consult the information provided with the equipment or contact the Blue Photon sales team for additional information.

FAILURE TO USE BLUEGRIP WORKHOLDING ADHESIVES AND BLUE PHOTON APPROVED EQUIPMENT WILL VOID ALL WARRANTIES AND MAY SUBJECT THE USER TO UNSAFE CONDITIONS.



Design Considerations

The user guide provides general operating procedures. Your specific application will have special considerations in setup, function and use. There are several design considerations that must be addressed before implementing

Blue Photon workholding. Review these considerations with your design and engineering teams, including the number and position of grippers, adhesive joint temperature, adhesive cure time, amount of adhesive, setting the part on applied adhesive, and part and gripper cleaning.



Safety Considerations

The user guide as well as additional manuals provide a description of the function, application and safety considerations of the Blue Photon system. These manuals must be read and understood before any attempt is made to install or use this system. Improper use could result in damage to the product or unsafe conditions for the user. Follow these safeguards to prevent serious injury or property damage.

Before you begin, refer to our user guide and read the manual carefully. In particular, pay attention to the warnings and cautions that appear in the safety and design sections at the front of the manual. For more information, visit our website for the most up-to-date product and safety information: www.BluePhotonGrip.com.

Sales and Engineering Support
Blue Photon Technology & Workholding Systems LLC
1002 Industrial Park Dr., Shelby, MI 49455
855-777-2040 • sales@BluePhotonGrip.com





2021 Product Catalog

INTRODUCTION

Blue Photon Markets

Blue Photon's innovative workholding system is solving problems for manufacturers throughout many different industries.

Blue Photon offers fixture design and engineering for milling, turning, grinding, electrical discharge machining (EDM), laser, inspection, and assembly applications; including aerospace, additive, robotics, optical, and medical machining.

From machining food processing equipment to powering jet propulsion, Blue Photon is unlike any workholding system in the world. Ask us how to put Blue Photon to work for you in your applications.

The Blue Photon Difference

What makes Blue Photon unique?

The grippers and BlueGrip adhesives create a versatile and simplified workholding system that can give you:

- Less scrap
- Less damage
- No or reduced part distortion
- Fewer operations
- Lower cost
- Higher efficiency
- Improved part access
- Improved accuracy
- Simplified fixture design

The Blue Photon workholding system:

- Holds ceramic and glass
- Holds composite and laminate materials
- Holds plastics
- Holds irregular and complex shaped parts
- Stands up to oils and cutting fluids
- Stands up to heavy machining



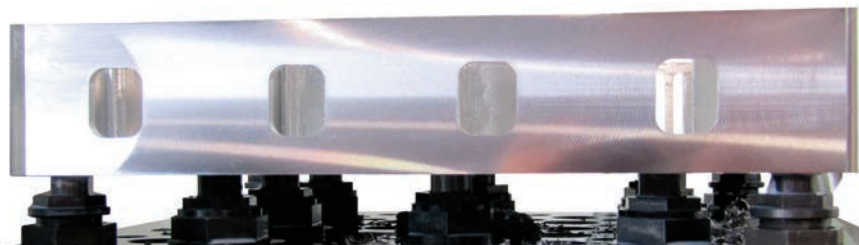

P/N	DESCRIPTION	PAGE
GRIPPERS		
11130	Small Gripper	6-7
11131	Small Corrosion Resistant Gripper	6-7
14130	Metric Small Gripper	6-7
14131	Metric Small Corrosion Resistant Gripper	6-7
14230	Metric Small Gripper	6-7
14231	Metric Small Corrosion Resistant Gripper	6-7
12130	Medium Gripper	6-7
12131	Medium Corrosion Resistant Gripper	6-7
15130	Metric Medium Gripper	6-7
15131	Metric Medium Corrosion Resistant Gripper	6-7
12230	Medium Gripper	6-7
12231	Medium Corrosion Resistant Gripper	6-7
15230	Metric Medium Gripper	6-7
15231	Metric Medium Corrosion Resistant Gripper	6-7
13160	Large Gripper	6-7
13161	Large Corrosion Resistant Gripper	6-7
16160	Metric Large Gripper	6-7
16161	Metric Large Corrosion Resistant Gripper	6-7
13260	Large Gripper	6-7
13261	Large Corrosion Resistant Gripper	6-7
16260	Metric Large Gripper	6-7
16261	Metric Large Corrosion Resistant Gripper	6-7
INSERTS		
22100	Medium Gripper Internal Insert	8-9
25100	Metric Medium Gripper Internal Insert	8-9
23100	Large Gripper Internal Insert	8-9
26100	Metric Large Gripper Internal Insert	8-9
22200	Medium Gripper External Insert	8-9
25200	Metric Medium Gripper External Insert	8-9
23200	Large Gripper External Insert	8-9
26200	Metric Large Gripper External Insert	8-9
50200	3/8 Drive Ratchet	9
53595	3/8 Drive 9/16 Thin Wall Socket	9
54595	3/8 Drive 12 mm Thin Wall Socket	9
57595	3/8 Drive 5/16 Thin Wall Socket	9

P/N	DESCRIPTION	PAGE
WORKHOLDING ADHESIVES		
43200	BlueGrip S2 Workholding Adhesive, 30 cc	11
46200	BlueGrip S2 Workholding Adhesive, 1L	11
43210	BlueGrip S2-F Fluorescent Workholding Adhesive, 30 cc	11
46210	BlueGrip S2-F Fluorescent Workholding Adhesive, 1L	11
KITS		
	Workholding Kit	12-13
91100	Universal Fixture Kit	14
UNIVERSAL FIXTURE KIT COMPONENTS		
91101-000	Z Locator Assembly	14-15
91102-000	XY Locator Assembly	14-15
91103-200	2" Vertical Gripper Arm Assembly	14-15
91103-300	3" Vertical Gripper Arm Assembly	14-15
91103-400	Horizontal Gripper Arm Assembly	14-15
91104-000	Pivoting Gripper Assembly	14-15
91105-100	12" x 12" Base Plate	14-15
91109-110	Shaft Foot	14-15
91109-420	1" dia Shaft, 2" Length	14-15
91109-440	1" dia Shaft, 4" Length	14-15
91109-460	1" dia Shaft, 6" Length	14-15
12130	Medium Head-In Gripper	14-15
64860	Right Angle Adapter, Extended Medium	14-15
LED CONTROLLER & ACCESSORIES		
65530	UV LED Controller, 2 Channel	16
65540	UV LED Controller, 4 Channel	16
56802	Small Adapter, 125 mm UV LED Head Assembly	16
56803	Medium Adapter, 125 mm UV LED Head Assembly	16
56804	Large Adapter, 125 mm UV LED Head Assembly	16
59802	Small Adapter, 55 mm UV LED Head Assembly	16
59803	Medium Adapter, 55 mm UV LED Head Assembly	16
59804	Large Adapter, 55 mm UV LED Head Assembly	16
50010	UV Safety Glasses	16
50907	3 ft Extension Cable	16
50908	6 ft Extension Cable	16
50909	10 ft Extension Cable	16
51705	Small Adapter	17



Grip Technology

TABLE OF CONTENTS

P/N	DESCRIPTION	PAGE
LED CONTROLLER & ACCESSORIES CONT.		
52705	Medium Adapter	17
57705	Large Adapter	17
64850	Right Angle Adapter, Standard Medium	17
64860	Right Angle Adapter, Extended Medium	17
64950	Right Angle Adapter, Standard Large	17
64960	Right Angle Adapter, Extended Large	17
62020	Handheld Radiometer	17
62600	UV LED Light Sensor	17
66700	Beam Positioning Kit	17
ADHESIVE DISPENSERS		
71906	Pneumatic Dispenser with Dispenser Adapter Assembly	18
75490	Electric Finger Switch	18
72006	Digital Pneumatic Dispenser with Dispenser Adapter Assembly	18
73006	High Precision Dispenser with Optimeter	18
74000	Manual Plunger	19
75500	Optimeter	19
75880	Dispenser Adapter Assembly	19
77707	5 Gallon Pail Dispenser	19
ADHESIVE ACCESSORIES		
43402	30 cc Syringe Barrel	20
46402	1L Cartridge Barrel	20
43700	30 cc Tip Cap	20
46700	1L Tip Cap	20
43800	30 cc End Cap	20
46802	1L End Cap	20
46600	Barrel Loader	20
48006	5 Gallon Pail Protector	20
CLEANING EQUIPMENT		
81100	Hot Water Spray Washer	21
81300	Soak Debond Tank	21
82400	Gripper Cleaning Tool Assembly	22
82500	Replacement Head	22
84750	Handheld Pressurized Steamer	22
80030	Scraper	22
84870	Cured Adhesive Steam Cleaner <i>approx. 6 hrs.</i>	23
84880	Cured Adhesive Steam Cleaner <i>min. 8 hrs.</i>	23
84890	Cured Adhesive Steam Cleaner <i>full-time steam</i>	23



GRIPPERS



Go to www.BluePhotonGrip.com for additional product info and to download tech specs. Click on [technical resources](#) for a list of all compatible materials.

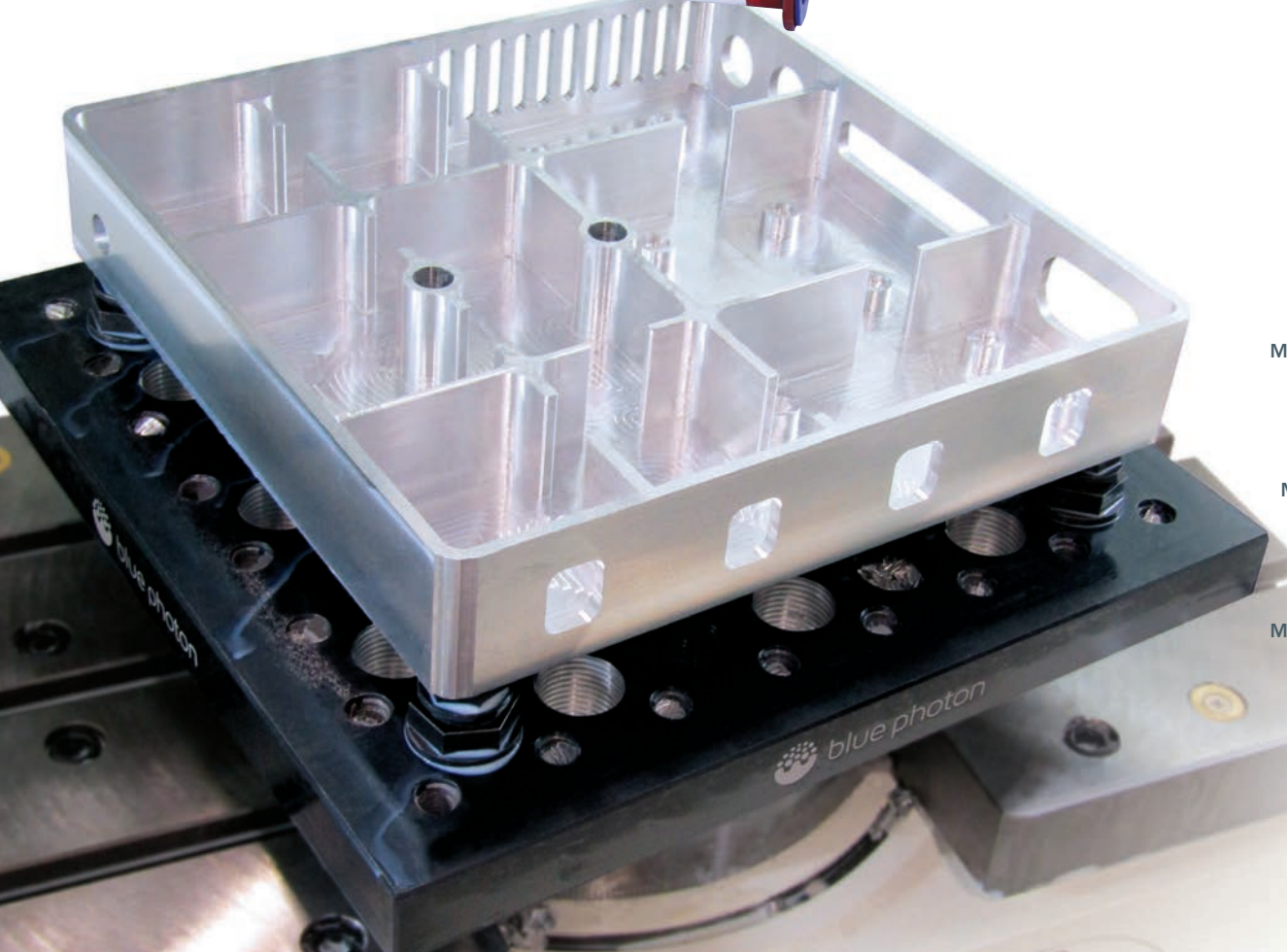

Small Head-In Gripper



Small Corrosion Resistant Head-In Gripper



Small Head-Out Gripper



Small Corrosion Resistant Head-Out Gripper



Medium Head-In Gripper



Medium Corrosion Resistant Head-In Gripper



Medium Head-Out Gripper



Medium Corrosion Resistant Head-Out Gripper



Large Head-In Gripper



Large Corrosion Resistant Head-In Gripper



Large Head-Out Gripper



Large Corrosion Resistant Head-Out Gripper

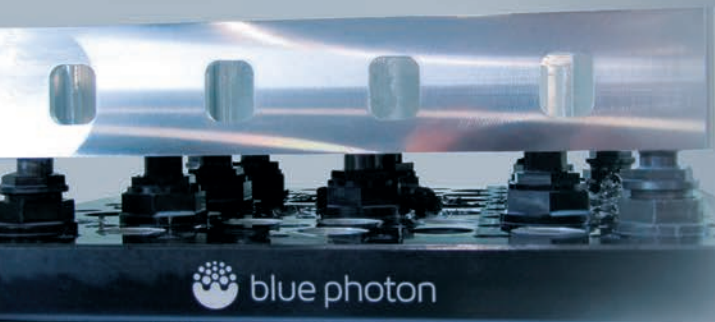

Unique workholding grippers that allow for complete BlueGrip workholding adhesive curing. Blue Photon's workholding grippers are a patented, load bearing and light transmitting fixture component. The grippers are inserted into a fixture. The workpiece is secured to the grippers with BlueGrip workholding adhesive, which is cured with UV light transmitted through the core of the gripper.

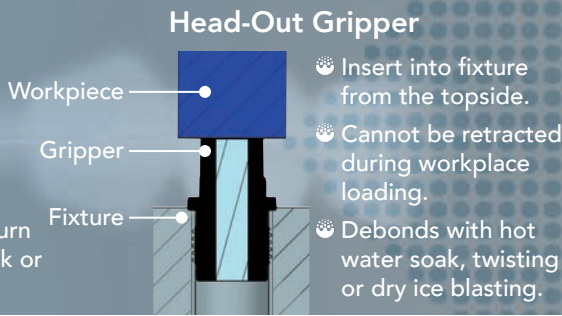
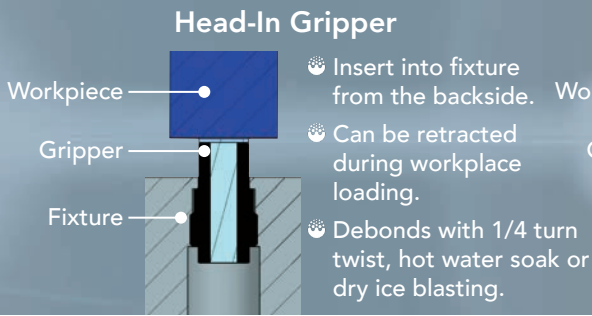

Small Head-In Gripper

Part #: 11130 - Imperial Part #: 14130 - Metric
 Part #: 11131 - Corrosion Resistant Part #: 14131 - Metric Corrosion Resistant

Features

- To hold small size workpieces for lighter duty machining.
- Average tensile holding power with BlueGrip S2 workholding adhesive is 200 lbs.*
- Use P/N 11131** and 14131** where deionized water is used.

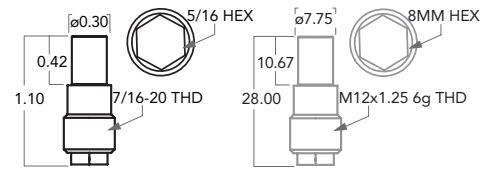

Small Head-Out Gripper

Part #: 14230 - Metric
 Part #: 14231 - Metric Corrosion Resistant

Features

- To hold small size workpieces to apply added stand-off to .55".
- Use in applications for simplified fixture design.
- Average tensile holding power with BlueGrip S2 workholding adhesive is 200 lbs.*
- Use P/N 14231** where deionized water is used.

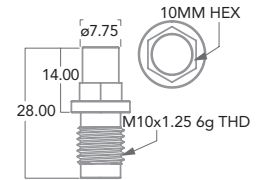

Medium Head-In Gripper

Part #: 12130 - Imperial Part #: 15130 - Metric
 Part #: 12131 - Corrosion Resistant Part #: 15131 - Metric Corrosion Resistant

Features

- To hold small to medium size workpieces.
- Average tensile holding power with BlueGrip S2 workholding adhesive is 400 lbs.*
- Use P/N 12131** and 15131** where deionized water is used.

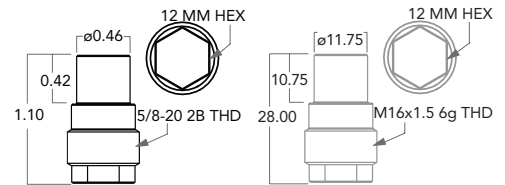

Medium Head-Out Gripper

Part #: 12230 - Imperial Part #: 15230 - Metric
 Part #: 12231 - Corrosion Resistant Part #: 15231 - Metric Corrosion Resistant

Features

- To hold small to medium size workpieces to apply added stand-off to .55".
- Use in applications for simplified fixture design.
- Average tensile holding power with BlueGrip S2 workholding adhesive is 400 lbs.*
- Use P/N 12231** and 15231** where deionized water is used.

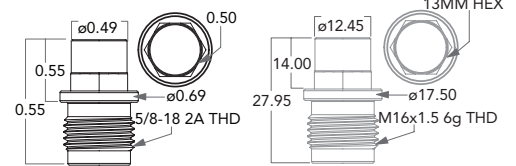

Large Head-In Gripper

Part #: 13160 - Imperial Part #: 16160 - Metric
 Part #: 13161 - Corrosion Resistant Part #: 16161 - Metric Corrosion Resistant

Features

- To hold medium to large size workpieces.
- Offers more surface area on gripper head for stronger holding power.
- Average tensile holding power with BlueGrip S2 workholding adhesive is 605 lbs.*
- Use P/N 13161** and 16161** where deionized water is used.

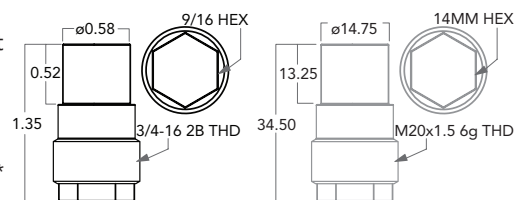

Large Head-Out Gripper

Part #: 13260 - Imperial Part #: 16260 - Metric
 Part #: 13261 - Corrosion Resistant Part #: 16261 - Metric Corrosion Resistant

Features

- To hold medium to large size workpieces to apply added stand-off to .55".
- Use in applications for simplified fixture design.
- Average tensile holding power with BlueGrip S2 workholding adhesive is 605 lbs.*
- Use P/N 13261** and 16261** where deionized water is used.

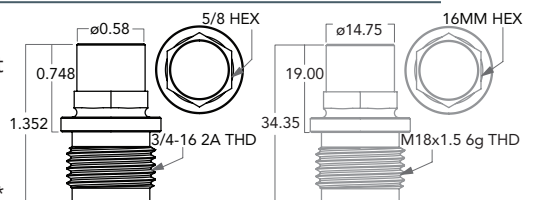

INSERTS



Consult a [Blue Photon Representative](#) or the factory on turning applications.

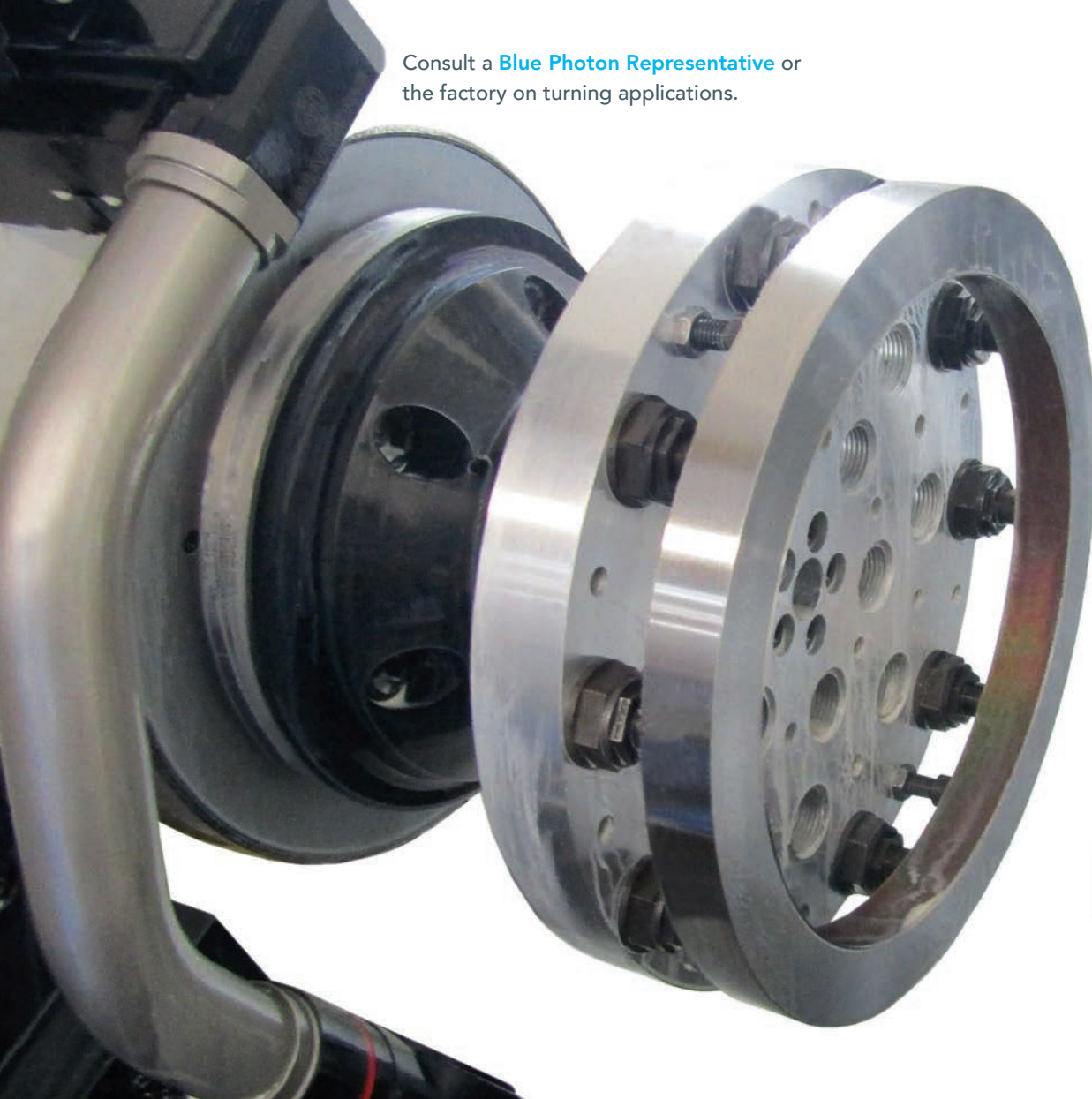

Medium Gripper Internal Insert



Medium Gripper External Insert



Large Gripper Internal Insert



Large Gripper External Insert



Blue Photon's workholding inserts work with specifically developed fixturing systems to grip and secure the workpiece to provide superior holding power. The external insert assembly includes the gripper insert and nut to increase standoff from the fixture and/or to protect aluminum fixtures from thread galling.



Gripper External Insert Assembly

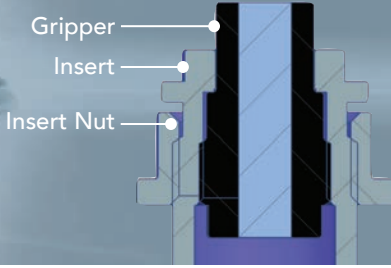

- Insert into fixture from the backside.
- Can be retracted during workplace loading.
- Debonds with 1/4 turn twist, hot water soak or dry ice blasting.

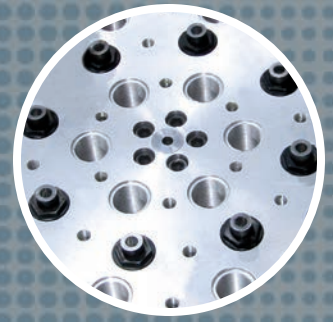

Gripper Internal Insert

Part #: 22100 - Medium internal insert to use with gripper P/N 12130

Part #: 25100 - Metric medium internal insert to use with gripper P/N 15130

Part #: 23100 - Large internal insert to use with gripper P/N 13160

Part #: 26100 - Metric large internal insert to use with gripper P/N 16160

Features

- Use gripper inserts to protect aluminum fixtures from thread galling.
- Made from hardened steel with a black oxide finish.
- Install with thread locker.
- Screws in from the bottom.

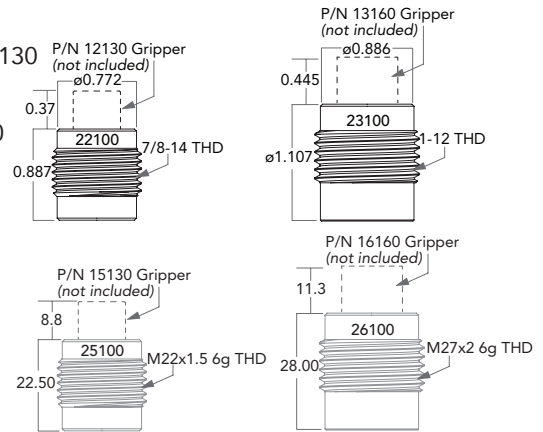

Gripper External Insert

Part #: 22200 - Medium external insert to use with gripper P/N 12130

Part #: 25200 - Metric medium external insert to use with gripper P/N 15130

Part #: 23200 - Large external insert to use with gripper P/N 13160

Part #: 26200 - Metric large external insert to use with gripper P/N 16160

Features

- Includes the gripper insert and insert nut.
- Use to increase standoff from the fixture and/or to protect aluminum fixtures from thread galling.
- Inserts allow for additional flexibility for exact gripper height positioning.
- Made from hardened steel with a black oxide finish.
- Screws in from the top.

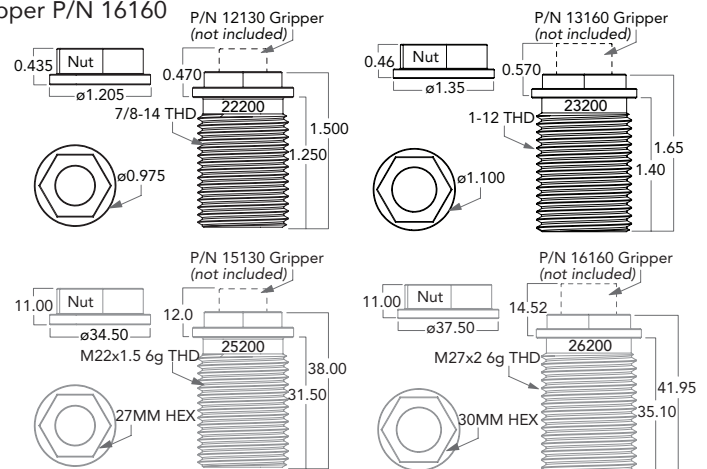

Ratchet and Sockets

Grippers debond with 1/4 turn twist of ratchet.

Part #: 50200 - 3/8 drive ratchet use with sockets P/N 53595, 54595 and 57595

Part #: 53595 - 3/8 drive 9/16 thin wall socket use with large grippers

Part #: 54595 - 3/8 drive 12 mm thin wall socket use with medium grippers

Part #: 57595 - 3/8 drive 5/16 thin wall socket use with small grippers



P/N 50200



P/N 53595



P/N 54595



P/N 57595

WORKHOLDING ADHESIVES



BlueGrip workholding adhesive is designed specifically and exclusively for Blue Photon's workholding system. The gel-like adhesive fills the gap between the surface of the gripper and the surface of the workpiece for outstanding holding power. Joint thickness can range from .020" to .120".
Technical glass images courtesy of S.I. Howard Glass Co., Inc.



BlueGrip™ Workholding Adhesives

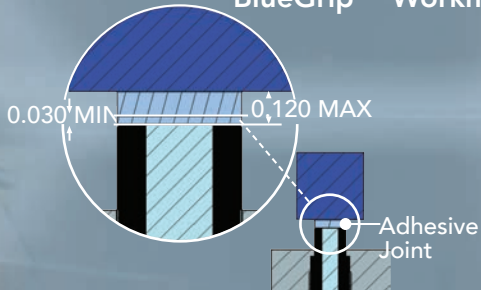

- Works on ferrous and non-ferrous metals, ceramics, composite materials and most plastics.
- Cures in 60 seconds.
- Impervious to cutting fluids and oils.
- Removable with steam or hot water.
- Available with a fluorescent dye.



BlueGrip™ S2 Workholding Adhesive

Specifically formulated for Blue Photon's photo-activated adhesive workholding.

Part #: 43200 - 30 cc syringe

Part #: 46200 - 1L cartridge

Features

- 30 cc syringes are for manual and pneumatic dispensing.
- 1L cartridges for automated dispensing, see page 19 for additional information.
- BlueGrip S2 workholding adhesive is curable with heat.
- Impervious to most cutting fluids and oils.
- Easily removable with CNC machine mounted cleaning tool, hot water, steam, hot water spray or dry ice blasting.
- Fills gaps between the gripper and workpiece of .020" to .120".



BlueGrip™ S2-F Fluorescent Workholding Adhesive

Specifically formulated with a dye that fluoresces under black light for easy identification of residual adhesive on workpieces and grippers.

Part #: 43210 - 30 cc syringe

Part #: 46210 - 1L cartridge

Features

- 30 cc syringes are for manual and pneumatic dispensing.
- 1L cartridges for automated dispensing, see page 19 for additional information.
- Impervious to most cutting fluids and oils.
- Easily removable with CNC machine mounted cleaning tool, hot water, steam, hot water spray or dry ice blasting.
- Fills gaps between the gripper and workpiece of .020" to .120".



WORKHOLDING KIT

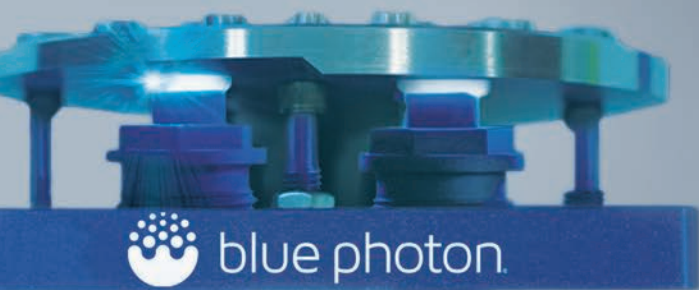

The basic starter workholding kit includes everything you need to start using Blue Photon's workholding technology. We offer simple solutions to solve your workholding problems. The workholding kit includes grippers of your preferred style and size bundled with a UV LED controller, light heads, adhesive, plunger and steamer.



WORKHOLDING KIT





The Workholding Kit includes everything you need to start using the Blue Photon workholding system for manufacturing your parts.

Part Number Configurator

Select your kit based on the configuration below:

Kit	Measuring System	Gripper*	Controller	UV LED Head Assembly	UV LED Head Qty.	Insert**
3	<input type="checkbox"/>	<input type="checkbox"/>	<input type="checkbox"/>	<input type="checkbox"/>	<input type="checkbox"/>	<input type="checkbox"/>
	2 - Imperial	1 - Small Head-In Gripper	1 - 2 Channel	1 - Small Adapter and 55 mm Head Length	1	1 - Medium Gripper Internal Insert
	3 - Metric	2 - Small Head-Out Gripper	2 - 4 Channel	2 - Small Adapter and 125 mm Head Length	2	2 - Medium Gripper External Insert
		3 - Medium Head-In Gripper		3 - Medium Adapter and 55 mm Head Length	3	3 - Large Gripper Internal Insert
		4 - Medium Head-Out Gripper		4 - Medium Adapter and 125 mm Head Length	4	4 - Large Gripper External Insert
		5 - Large Head-In Gripper		5 - Large Adapter and 55 mm Head Length		
		6 - Large Head-Out Gripper		6 - Large Adapter and 125 mm Head Length		

In addition to your selections above, each kit contains:

-  BlueGrip S2 Workholding Adhesive
-  Manual Plunger
-  Scraper
-  Handheld Steamer (Actual unit may vary from one shown.)

*6 grippers included within each kit. **Inserts optional with kit order.

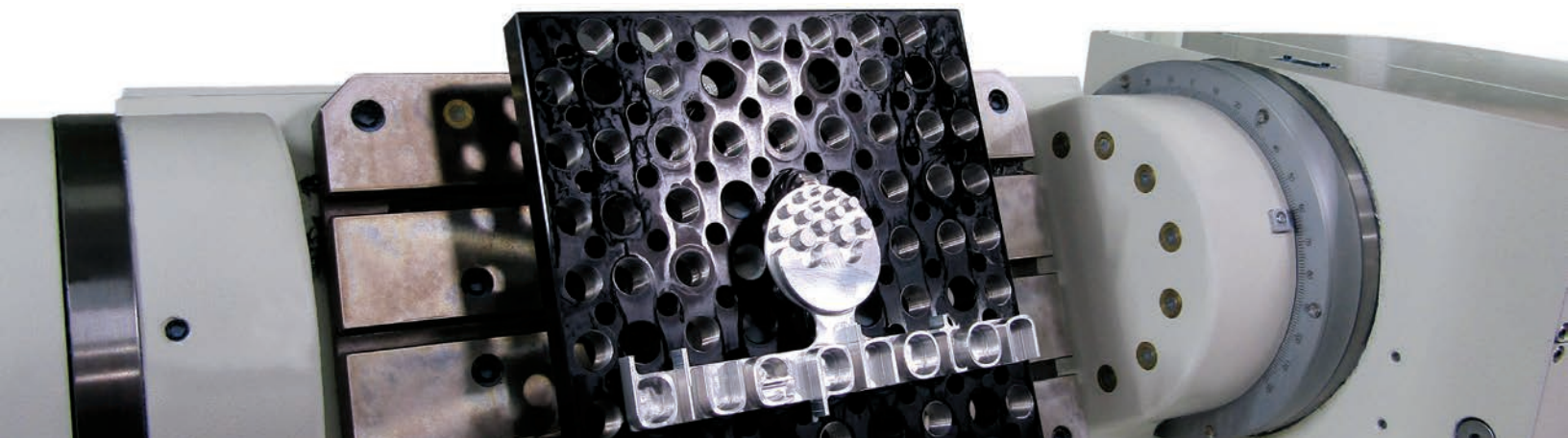

UNIVERSAL FIXTURE KIT & COMPONENTS



Part #: 91100 - Universal Fixture Kit

Each kit includes the following components:

P/N	QTY	DESCRIPTION
91101-000	3	Z Locator Assembly
91102-000	3	XY Locator Assembly
91103-200	2	2" Vertical Gripper Arm Assembly
91103-300	4	3" Vertical Gripper Arm Assembly
91103-400	2	Horizontal Gripper Arm Assembly
91104-000	2	Pivoting Gripper Assembly
91105-100	1	12" x 12" Base Plate*
91109-110	9	Shaft Foot
91109-420	2	1" dia Shaft, 2" length
91109-440	4	1" dia Shaft, 4" length
91109-460	3	1" dia Shaft, 6" length
12130	6	Medium Head-In Gripper
64860	1	Right Angle Adapter, Extended Medium

Kit sold as a unit. *Custom sizes available upon request.

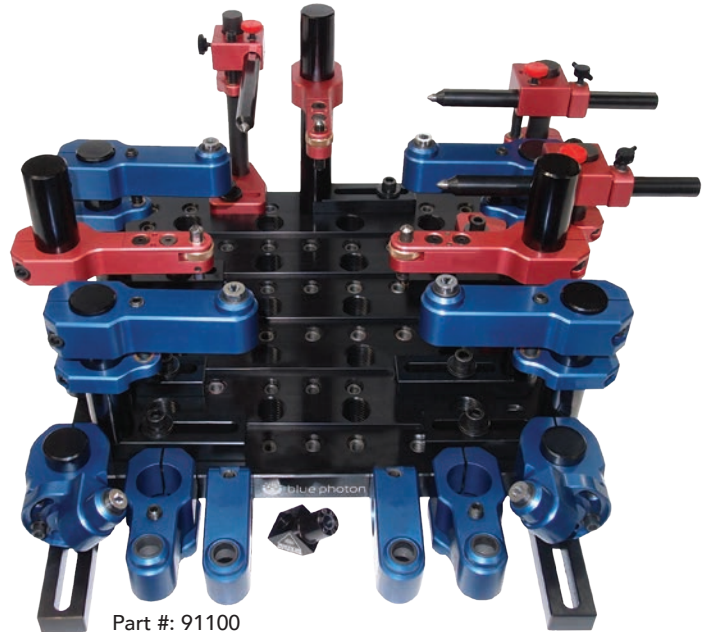

Part #: 91100
Universal Fixture Kit
Entire standard kit shown.

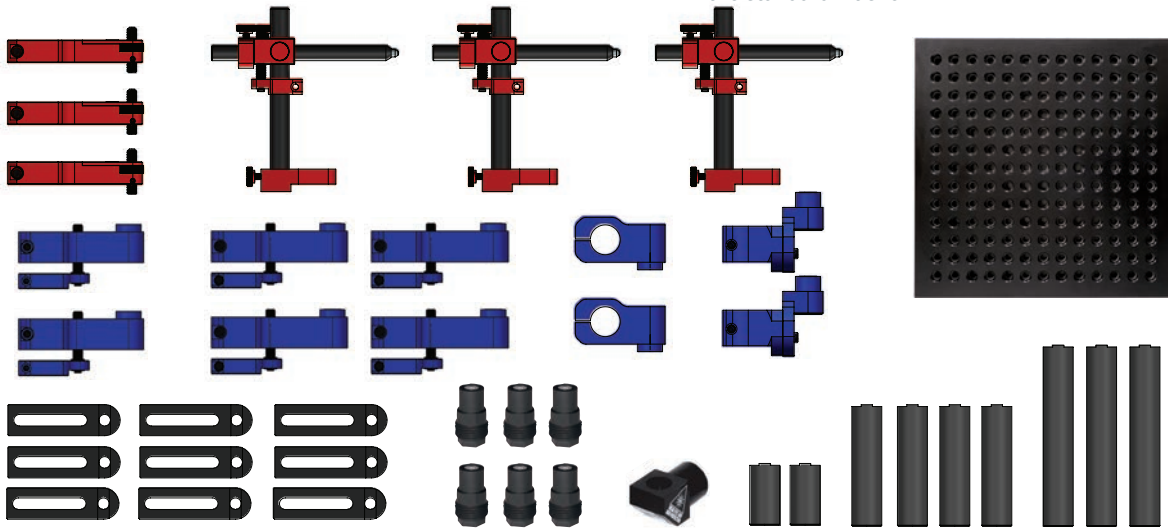

Blue Photon's groundbreaking universal fixture kit revolutionizes rapid prototyping. The universal fixture kit saves time and money for prototyping, one-offs and low volume parts because of its capability to easily hold near-net shaped parts; including parts that are generated by additive manufacturing. This results in lower fixture costs, and quick turnaround times.

This Universal Fixture Kit allows the user to very simply and immediately get started using Blue Photon workholding technology. The collection of included inserts, pins and articulating arms can be set up to hold a workpiece for 5- and even 6-sided tool access.



Part #: 91101-000
Z Locator Assembly



Part #: 91102-000
XY Locator Assembly



Part #: 91103-200
2" Vertical Gripper
Arm Assembly



Part #: 91103-300
3" Vertical Gripper
Arm Assembly



Part #: 91103-400
Horizontal Gripper
Arm Assembly



Part #: 91104-000
Pivoting Gripper
Assembly



Part #: 12130
Medium Head-In
Gripper



Part #: 64860
Right Angle Adapter,
Extended Medium

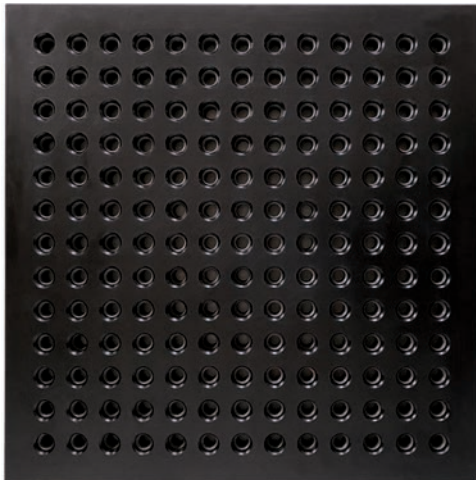

Part #: 91105-100
12" x 12" Base Plate



Part #: 91109-460
1" dia Shaft, 6" length



Part #: 91109-440
1" dia Shaft, 4" length



Part #: 91109-420
1" dia Shaft, 2" length



Part #: 91109-110
Shaft Foot

Blue Photon offers custom fixture solutions! Contact our engineers for assistance in designing application solutions.

LED CONTROLLER & ACCESSORIES



UV LED Controller

LX500 spot curing system has been uniquely designed with proprietary Intelli-Lamp® technology that monitors LED head temperature, lifetime data and automatically maintains optical stability +/- 5%.

Part #: 65530 - UV LED controller, 2 channel

Part #: 65540 - UV LED controller, 4 channel

Features

- 1-4 individual UV LED heads, interchangeable to any channel.
- 2.4 inches full color display with main control, input configurations, system maintenance, LED information, calibration and micro SD log information.
- 4-way membrane mode control for system display and programming.
- Start/stop – control start or stop of the LED emission.
- Alarm icon on screen in the event of an error or fault.
- External control via optional foot pedal, PLC or PC through USB communication.



UV LED Head Assembly

Gripper adapter and UV LED head cures BlueGrip workholding adhesive through grippers.

Part #: 56802 - Small adapter with 125 mm head length, 1M cable length

Part #: 56803 - Medium adapter with 125 mm head length, 1M cable length

Part #: 56804 - Large adapter with 125 mm head length, 1M cable length

Part #: 59802 - Small adapter with 55 mm head length, 1M cable length

Part #: 59803 - Medium adapter with 55 mm head length, 1M cable length

Part #: 59804 - Large adapter with 55 mm head length, 1M cable length

When ordering, use the above part numbers to specify small, medium or large adapter to coincide with gripper size.



UV Safety Glasses

Anti-scratch eyewear protection. Glasses offer 99% protection against harmful UV rays. Meets ANSI Z87.1.

Part #: 50010



Extension Cable

Provides extra cable length from the UV LED controller to the UV LED head where the UV curing process is farther away from the controller.

Part #: 50907 - 3 ft length

Part #: 50908 - 6 ft length

Part #: 50909 - 10 ft length

Features

- Cable type - USB
- Cable characteristic - extension cable
- Color - black



UV lightsource to quickly cure BlueGrip workholding adhesives. Curing the adhesive is a "60-90 second" proposition with our patented system, and we supply UV LED controllers, UV LED head assemblies and cables to do so. The controller is capable of operating multiple UV LED heads and is available with up to 4 channel configurations. We also supply handheld radiometers, long and short UV LED head assemblies, extension cables, gripper adapters and right angle adapters for various sizes of grippers.



Gripper Adapter

Gripper adapter with UV LED head cures BlueGrip workholding adhesive through grippers.

Part #: 51705 - Small adapter to use with UV LED head P/N 56802 or 59802

Part #: 52705 - Medium adapter to use with UV LED head P/N 56803 or 59803

Part #: 57705 - Large adapter to use with UV LED head P/N 56804 or 59804

When ordering, please specify small, medium or large adapter to coincide with gripper size.



Right Angle Adapter

Attaches to the UV LED head when clearance issues arise.

Part #: 64850 - Standard medium adapter use with medium grippers

Part #: 64860 - Extended medium adapter use with medium grippers

Part #: 64950 - Standard large adapter use with large grippers

Part #: 64960 - Extended large adapter use with large grippers



Handheld Radiometer

Measures stray UV light output in the range of 280 to 400 nm.

Part #: 62020

Features

- Measuring Range - 1 to 1999 uW/cm², 0.01 to 40 mW/cm²
- Accuracy +/- 4% +/- 1 Digit
- Display - Backlit 4 Digit LCD
- Data Hold
- Min./Max. Memory
- Memory - 20 Point
- Battery Type - 9V
- Cord Length - 46 inches
- Calibration Certificate - NIST



UV LED Light Sensor

Measures UV light output from LED head.

Part #: 62600 - UV LED light sensor use with P/N 66700

Features

- Accuracy +/- 10%
- Calibration Cycle - One Year
- Operating Temperature Range - Ambient to 40° Centigrade
- Certification - Complies with IEC, Canadian and US Standards, RoHS compliant
- Traceability - NIST and NRC Compliant
- Sensor Dimension (LxWxH) - 75 mm x 25 mm x 11.95 mm



Beam Positioning Kit

Centers the LED head over the UV sensor. Consistent measurements by accurately positioning the beam on the detector sensor.

Part #: 66700 - Beam positioning kit use with P/N 62600



ADHESIVE DISPENSERS



Pneumatic Dispenser with Dispenser Adapter Assembly

Pneumatic adhesive dispensing unit with digital time/pressure display.

Part #: 71906

Features

- Digital time/pressure display.
- Timed or steady modes of operation.
- Vacuum control keeps thin fluids from dripping between cycles.
- Dispenser adapter assembly (P/N 75880) included to operate dispenser.
- Optional electric finger switch (P/N 75490) available to order with pneumatic dispenser.



Digital Pneumatic Dispenser with Dispenser Adapter Assembly

Fully digital adhesive dispenser with all-digital, multi-function display and 16 memory settings.

Part #: 72006

Features

- Foot-operated adhesive dispenser.
- All-digital, multi-function display.
- Multilingual display.
- Operator security lockout.
- 16 memory settings and a 4-decimal time setting.
- High-speed solenoid for highly accurate deposits.
- Dispenser adapter assembly (P/N 75880) included to operate dispenser.
- Universal power supply.



High Precision Dispenser with Optimeter

Includes controls and settings to electronically change/adjust dispensing time, pressure and vacuum. Consists of an auto-increment feature to adjust dispensing parameters after a certain number of shots or a specific lapsed time and auto-sequence mode that allows deposit patterns to be repeated automatically.

Part #: 73006

Features

- 400 individual memory storage cells.
- Scroll or select cells via front panel keypad or external PC/PLC control.
- Switch between steady, timed and teach modes.
- Front panel manual cycle key.
- Teach function.
- Multi-level operator lockout.
- Alarm indicators.
- End of cycle feedback loop.
- Soft button data input 0-9 keypad.
- Operator control of LCD display brightness.
- Easy up/down arrow key navigation.
- External PC interface for data input.
- Display cycle counter.
- RS-232 communication capability.
- ESD safe via connection with external ESD.
- 0-100 psi (0-6.9) bar air regulation range.
- D-sub I/O (15-pin) and communication (9-pin) connections.
- Alarm I/O signals.
- Optimeter (P/N 75500) included to operate dispenser.



Manual or automated adhesive dispensers for Blue Photon's workholding system. From a simple, manual plunger to sophisticated, automated and precise delivery, Blue Photon offers a range of adhesive dispensers compatible with BlueGrip workholding adhesives. Options include pneumatic dispenser, digital pneumatic dispenser and a high precision dispenser.

Contact us for help selecting the best adhesive dispensing equipment for your application.



Manual Plunger

Plunger fits into 30 cc adhesive tubes for dispensing by hand.

Part #: 74000



Optimeter

Specifically designed to provide greater control when dispensing adhesives by automatically increasing airflow as the syringe barrel empties.

Part #: 75500

Features

- Blue 6 ft (1.8 m) hose.
- Included with the high precision dispenser (P/N 73006) to operate dispenser using 30 cc adhesive tubes.
- Increases accuracy and consistency through precise mechanical regulation.



Dispenser Adapter Assembly

Adapter fits onto 30 cc adhesive tubes for dispensing with pneumatic dispensers.

Part #: 75880

Features

- Blue 6 ft (1.8 m) hose.
- Required in order to operate all automated dispensers using 30 cc adhesive tubes.
- Designed with a positive safety locking action to prevent accidental disengagement, adapters are easy to install and remove.
- Each adapter assembly is precision molded for secure attachment to the adhesive tube with minimal effort, making its connection to the air output of a fluid dispensing unit fast and seamless.



5 Gallon Pail Dispenser

For efficient dispensing of BlueGrip workholding adhesives. Highly efficient unloading for one component material, using durable components, and wear resistant coatings.

Part #: 77707

- Single-post unloader
- Manual bulk filling station
- Use to fill 1L cartridges

Features

- **Dispensing Consistency** – Fast air motor changeover with rapid-cycling, dual air-piloted cylinder provides uniform material output and consistent material pressure.
- **Ease of Operation** – Simple and intuitive front facing pneumatic controls that feature auto shutdown to prevent damage to the unit when the pump reaches the bottom of the container.
- **Minimize Waste** – Unique plunger seal design and low waste follower reduce the risk of costly material waste/loss due to leakage and/or unused material remaining in the pail.
- **Speed of Maintenance** – Removable packing gland provides fastest repair in industry, without having to remove the pump from the line.
- **Production Efficiencies** – Interchangeable follower plate and seal design reduce wasted material and lengthy changeover procedures.
- **Safety Compliance** – Tapered solvent cup and finger safe design for CE compliance.
- **Easy Pail Changeover** – Pail hold down feature facilitates ease of container changeover procedure, preventing movement when the follower is withdrawn.



Automated recommendations available upon request.

ADHESIVE ACCESSORIES



Syringe and Cartridge Barrels

UV blocking barrels block UV light, while allowing fluid levels to be monitored.

Part #: 43402 - 30 cc amber syringe barrel with piston and label, 20 per box

Part #: 46402 - 1L amber cartridge barrel with piston and label, 10 per box



Tip Caps

Tip caps protect assembly fluids with unique vents that are engineered to actually prevent air from being introduced into the syringe during installation.

Part #: 43700 - Use to cap 30 cc amber syringe barrel, 20 per box

Part #: 46700 - Use to cap 1L amber cartridge barrel, 10 per box



End Caps

End caps fit securely over syringe and cartridge tabs, and feature a center push button that makes it easy to create a snug, airtight seal.

Part #: 43800 - Use to cap 30 cc amber syringe barrel, 20 per box

Part #: 46802 - Use to cap 1L amber cartridge barrel, 10 per box



Barrel Loader

Barrel-filling system for BlueGrip workholding adhesive.

Part #: 46600

Features

- 1L cartridge reservoir.
- Includes stand with retainer block.
- Use to fill 30 cc syringes from a 1L cartridge.



5 Gallon Pail Protector

Optional pail protectors to extend seal life and reduce clean-up of BlueGrip workholding adhesive. To be inserted between the dispenser follower plate and the adhesive in the pail.

Part #: 48006 - 10 per box

CLEANING EQUIPMENT

Debonding and clean up is simple with Blue Photon. Blue Photon offers a variety of soak tanks, pressure washers and cleaning tools to efficiently debond the workpiece and remove any cured, residual adhesive. Contact us for more information about our cleaning equipment and methods.



Hot Water Spray Washer

The hot water spray washer is designed with a pressurized hot water spray chamber for part and gripper cleaning.

Part #: 81100

Features

- Temperature control
- All wetted parts made of stainless steel
- Ergonomic design
- Adjustable height
- Foot switch operation for pressurized spray

Product Specifications*

- Voltage - 120VAC
- Phase - 1
- Supply Current - 20A
- Largest Load Current - 14.5A
- Max Water Capacity - 15-18 gallons

**This washer can be custom fabricated to accommodate any size part.*



Soak Debond Tank

The soak debond tank allows for debonding the part from the grippers without twisting. This method is preferred in applications where twist debonding could cause delamination or other damage to the workpiece.

Part #: 81300

Features*

- Stainless steel construction
- Electric heat
- Programmable temperature control/sensor
- Simple push button cycle operation
- Easy access for clearing and maintenance
- High performance insulation to avoid heat loss
- Thermal insulation
- Easy fill and drain tank
- Low energy consumption
- Emergency stop button
- Dipping time timer
- Manual or automatic operation
- No water alarm light
- Interlock casters

Product Specifications

- Maximum product height - 10 inches (255 mm)
- Immersion platform size - 23 x 14 inches (584 x 355mm)
- Immersion depth - 12 inches (305 mm)
- Cycle time - up to 15/min.
- Volume of water - 100 liters
- Electrical - 220V / 60 Hz / 3 Ø, 10 amps
- Machine size - 27 L x 33.5 W x 57.25 H inches (673 x 1016 x 1454mm) with cover up (63 H inches (1600mm))
- Weight - 394 lb (179 kg)

**All external walls of the unit are insulated to help protect from hot surface contact. All specifications subject to change.*



CLEANING EQUIPMENT

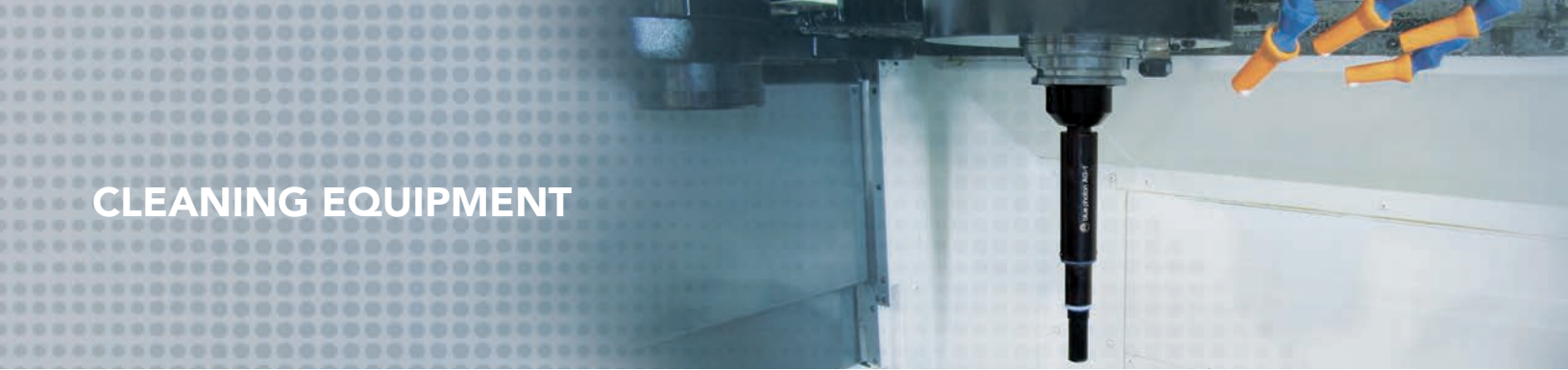

CNC Spindle Mounted Cleaning Tool

The spindle mounted gripper cleaning tool loads in a CNC machine to remove cured adhesive from grippers.

Part #: 82400 - Gripper Cleaning Tool Assembly

Part #: 82500 - Replacement Head

Features

- Mounts in any 3/4 diameter collet or end mill holder.
- Replaceable head for P/N 82400 tool assembly.
- Cleans an estimated 1,000 grippers before replacing head.
- Do not use with corrosion resistant grippers.



P/N 82400



P/N 82500



Handheld Pressurized Steamer

The handheld steamer provides pressurized steam for easy removal of residual cured adhesive from grippers and workpieces. Economical solution for prototypes or low-volume parts.

Part #: 84750

Features*

- 8 x 5.2 x 10.7 inches
- 3 lbs
- 6 oz water capacity
- Emits steam continuously for 10 minutes
- 15 ft power cord
- 900W
- 200°F steam temperature

*Actual unit may vary from one shown.



Scraper

The scraper is used to clean parts and grippers of cured adhesive after heating.

Part #: 80030 - 5" aluminum handle knife with a heavyweight adhesive removing blade





CLEANING EQUIPMENT

Heavy Duty Steamers

Cured Adhesive Steam Cleaners

These heavy duty steamers produce 60 PSI to unlimited hours of continuous steam pressure, and reaches temperatures up to 221°F at the tip. These steamers are ideally suited for cleaning away cured adhesive on grippers.

Part #: 84870 - Approximately 6 hours of continuous steam

Features

- 110V/120V 1200W element
- 1.25 gallon, 4.5 L water capacity
- Low water light indicator
- 61 PSI, 4.1 bar operating pressure
- Pressure/safety switch
- 30A heavy-duty contactor
- 12-gauge heavy-duty wiring
- Stainless steel tank and outer casing
- Carrying handle
- 15-20 minute heat up time



Part #: 84880 - Minimum 8 hours of continuous steam

Features

- 110V/120V
- 2.37 gallon, 9 L water capacity
- 1200W heating element
- Visual water level indicator
- Low water light indicator
- Regular tap water
- Ranco pressure control/li>
- 12-gauge heavy-duty wiring
- Stainless steel tank and outer casing
- 2 incoloy heating elements (1-spare)
- Carrying handle
- 30-40 minute heat up time



Part #: 84890 - Full-time steam

Features

- 110V/120V
- Automatic shut-off of pump in case water supply is interrupted
- Boiler thermostat reset switch
- Heavy-duty adjustable feet
- Low water light indicator
- Regular tap water
- Ranco pressure control
- 12-gauge heavy-duty wiring
- 1 Incoloy heating elements
- Stainless steel tank and outer casing
- Blow down valve
- 20-30 minute heat up time
- 20-amp plug required
- Direct connection to a water line





COMPLETE METALWORKING SOLUTIONS

(800) 991-4225

www.ahbinc.com

ISO Certified

customerservice@ahbinc.com

