



EARTH-CHAIN

Power that works.

Magnetic Workholding



Material Handling



Surface Grinding Chucks



Magnetic Accessories



Indicator Arms



sPINner Deburring



MagVISE Magnetic Workholding

EPEM Electro-Permanent Chucks 4
ECB Permanent Magnetic Vises 8



EZ-Lift Material Handling

Lifting Magnets 10
Spreader Bars & Vertical Lifters 13

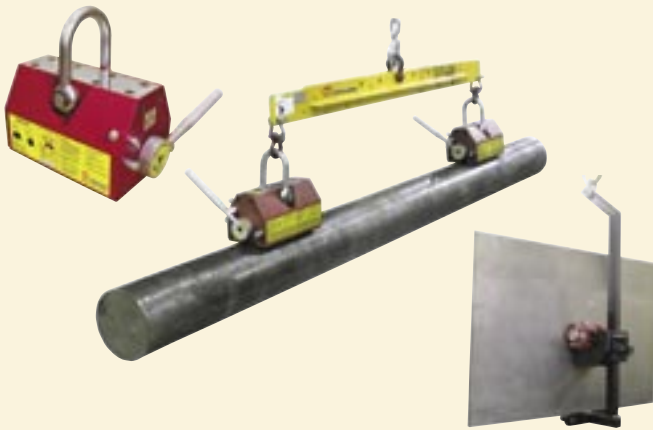

Surface Grinding / EDM Chucks

Permanent Magnetic Chucks 14
Electromagnetic Chucks 15
Induction Blocks 17

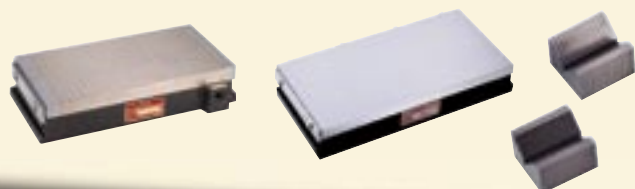

Surface Grinding Accessories

Chuck Controllers 18
Demagnetizers 18
V-Blocks 19

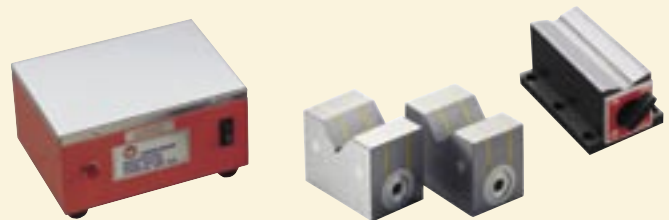

sPINner Deburring

sPINner Small Parts Deburring Machines . . . 20



"One Twist" Indicator Arms

Hydraulic and Mechanical Indicator Arms . . . 23



Techniks Certified Tooling

- Delivered to 25,000 RPMs
- Powder-Coated "T.I.E." only 2007"
- Under-structure design
- Power-Clamp tool provides 10% more holding power
- Each holder is air tested & certified for quality & accuracy

See the blue banner above to browse our tooling. Or visit our [3D-Shop](#) Web page. Click on the address bar above for more information.

Call: (800) 597-3921 or (317) 803-8000 or Fax: (317) 803-8000

Search:

View videos & case-studies at:
www.techniksusa.com

Toll-Free: (800) 597-3921
Local: (317) 803-8000
Fax: (317) 803-8035
email: info@earthchain.com

The Old Way v.s. The Earth Chain Way

The Old Way: Vises And Chucks

A) Vise For Each Size Workpiece

Limited ability to hold different size workpieces.

B) Part Distortion

Clamping pressure causes part distortion and dead spots that cause chatter.

C) Lost Productivity

Takes longer to setup and can't machine on 5 sides

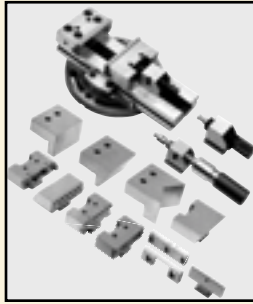

The Earth Chain Way: EEPM Magnetic Chucks

A) 26 Sizes To Choose From

Each chuck can handle small or large, and thick or thin workpieces.

B) Magnetic Holding

Eliminates dead areas that cause chatter.

C) Increase Productivity

Fast setups & tear-downs. Machine 5-sides and thru-hole machining.

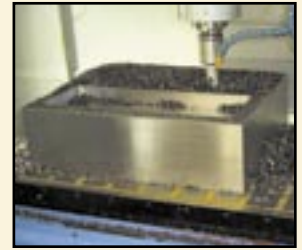

The Old Way: Modular Fixturing

A) Set It Up, Then Tear It Down

Flexible, but labor intensive setups and tear-downs.

B) Requires Training

Complicated systems require skilled operators.

C) Lost Productivity

Long setup times and can't machine on 5 sides.

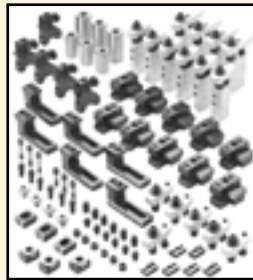

The Earth Chain Way: ECB Magnetic Vises

A) Fast Setups

Position ECB Blocks as needed on your machine bed using toe-clamps.

B) Anyone Can Use It

Fast & simple to use. Layout to fit your workpiece.

C) Increase Productivity

Cut hours of setup-time. Machine 5-sides.



The Old Way: Material Handling

A) Risk of Injury

Risk of injury to back, fingers, or toes when moving material in order to position sling or chain.

B) Slings & Chains Wear Out

Lifting equipment needs to be recertified and replaced periodically.

C) Lost Productivity

It takes time to properly setup slings or chains to safely move materials.



The Earth Chain Way: ELM Lifting Magnets

A) Safer – 3.5X Safety Factor

Simply center lifting magnet on workpiece to lift.

B) EZ-Lift Lasts Forever

Rare-Earth magnet will never wear out and uses no electricity.

C) Increase Productivity

EZ-Lift is the fastest and safest way to transport raw stock and workpieces.



Try It The Earth Chain Way

Thousands of customers use Earth Chain products to increase productivity, save money, and become more competitive. We offer state-of-the-art magnetic workholding, material handling, and deburring solutions at very competitive prices.

What makes us different, is we include full factory support before, during, and after the sale. Look to us when you need solutions that “load it & hold it” faster and safer.

Give us a try and see what we mean!

MagVISE EEPM Electro-Permanent Chucks

Features:

- Machine 5 sides and through-hole drilling
- Will not lose holding power during power outage
- Spring-loaded induction blocks hold warped stock



Even holding eliminates "dead spots", reduces chatter, and minimizes part deformation.

Use magnetic workholding for drilling, milling, and boring operations on thick or thin* workpieces. Magnetic power makes difficult workholding jobs faster and safer.

Our magnetic chucks easily integrate with pallet changing and tombstone systems used in production cells. Since no electricity is needed to keep the chuck ON, the electro-permanent magnet keeps on holding tight even during a complete power loss.

* Holding power varies with type of material and thickness.

Benefits:

- Cut set-up & part change-over times in half
- Improved machining for better finish and tool life
- Uniform holding = No workpiece deformation



Choose magnetic workholding for uniform holding of the workpiece, without part distortion or dead spots. Uniform workholding reduces chatter and harmonics for improved surface finish and tool life.



Magnetic chucks allow free access to machine on 5 sides

The Old Way: Vises And Chucks

A) Vise For Each Size Workpiece

Limited ability to hold different size workpieces.

B) Part Distortion

Clamping pressure causes part distortion and dead spots that cause chatter.

C) Lost Productivity

Takes longer to setup and can't machine on 5 sides

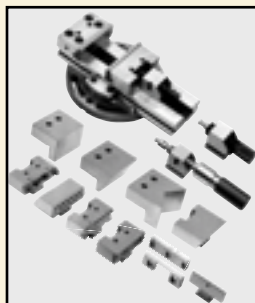

The Earth Chain Way: EEPM Magnetic Chucks

A) 26 Sizes To Choose From

Each chuck can handle small or large, and thick or thin workpieces.

B) Magnetic Holding

Eliminates dead areas that cause chatter.

C) Increase Productivity

Fast setups & tear-downs. Machine 5-sides and thru-hole machining.



MagVISE EEPM Application Examples

See a video of the EEPM chucks in action on our website: www.techniksusa.com

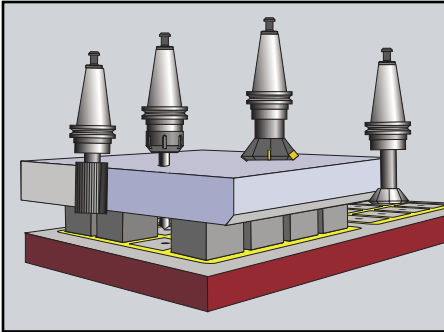

Machine 5 sides freely and thru-hole drill



Face milling warped stock



Works great for machining mold cavities

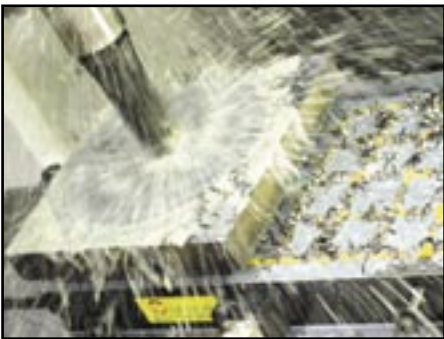

Flood coolant hole making application

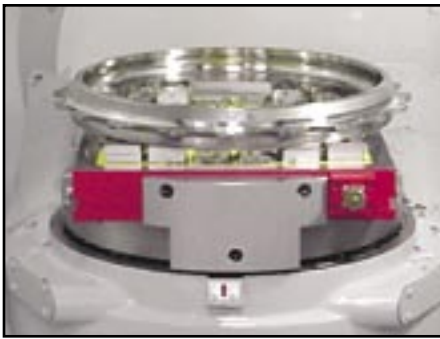

5 axis machining



Rotary Table application

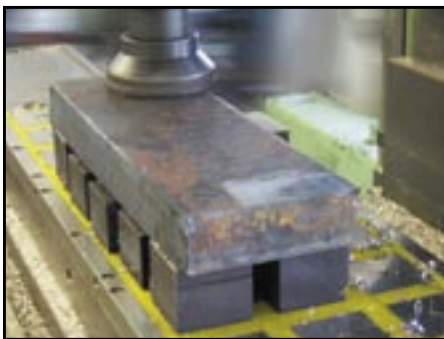

Spring-blocks adjust to hold warped stock

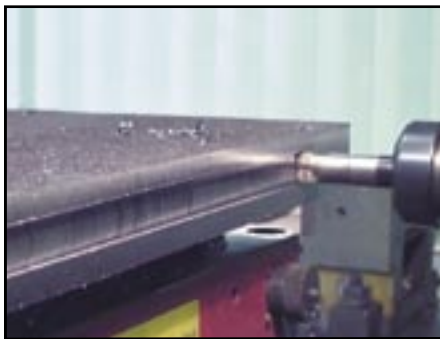

Heavy side loads



Fast setups and part turnover

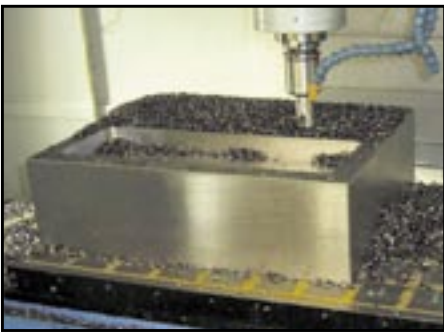

Works on thick or thin workpieces



Holding power to take big cuts

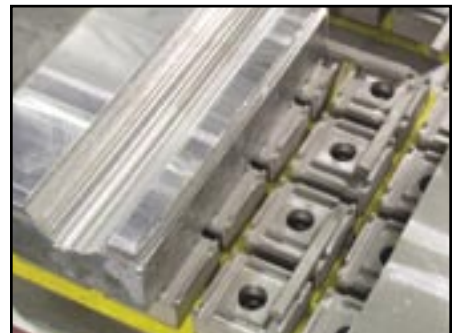

Use induction blocks as work stops

MagVISE EEPM Electro-Permanent Chucks

Ordering Electro-Permanent Chucks:

- Workpiece should cover at least 4 poles for maximum holding power.
- Workpiece should be at least 0.4" thick
- Controller is included. Order subplates separately.

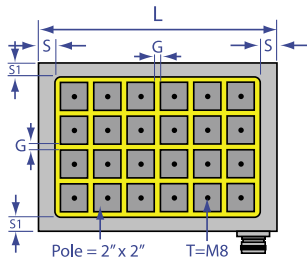

Fig. 1

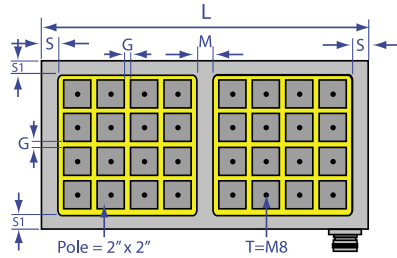

Fig. 2

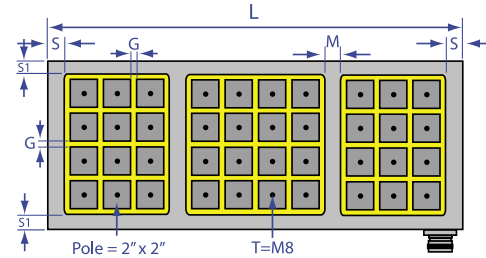

Fig. 3

S = 1.2"
SI = 1"
G = 0.4"
M = 1.2"

Model	Fig	L x W x H	Poles	Amps	Chuck Wt.	Subplates*	Controller
EEPМ-2540W	1	16.9" x 9.4" x 2.8"	18	30	110 lbs.	EEPМ-2540ISP	EEPМ-C1
EEPМ-2560W	2	23.2" x 9.4" x 2.8"	24	30	152 lbs.	EEPМ-2560ISP	EEPМ-C1
EEPМ-2580W	3	31.9" x 9.4" x 2.8"	33	30	202 lbs.	EEPМ-2580ISP	EEPМ-C1
EEPМ-2590W	3	34.3" x 9.4" x 2.8"	36	30	216 lbs.	EEPМ-2590ISP	EEPМ-C2
EEPМ-25100W	3	39.0" x 9.4" x 2.8"	42	30	244 lbs.	EEPМ-25100ISP	EEPМ-C2
EEPМ-3030W	1	12.2" x 11.8" x 2.8"	16	30	97 lbs.	EEPМ-3030ISP	EEPМ-C1
EEPМ-3040W	1	16.9" x 11.8" x 2.8"	24	30	134 lbs.	EEPМ-3040ISP	EEPМ-C1
EEPМ-3060W	2	23.2" x 11.8" x 2.8"	32	30	180 lbs.	EEPМ-3060ISP	EEPМ-C1
EEPМ-3080W	3	31.9" x 11.8" x 2.8"	44	30	255 lbs.	EEPМ-3080ISP	EEPМ-C2
EEPМ-3090W	3	34.3" x 11.8" x 2.8"	48	30	271 lbs.	EEPМ-3090ISP	EEPМ-C2
EEPМ-30100W	3	39.0" x 11.8" x 2.8"	56	30	304 lbs.	EEPМ-30100ISP	EEPМ-C2
EEPМ-4040W	1	16.9" x 16.5" x 2.8"	36	30	185 lbs.	EEPМ-4040ISP	EEPМ-C2
EEPМ-4050W	1	18.9" x 16.9" x 2.8"	42	30	209 lbs.	EEPМ-4050ISP	EEPМ-C2
EEPМ-4060W	2	23.2" x 16.5" x 2.8"	48	30	255 lbs.	EEPМ-4060ISP	EEPМ-C2
EEPМ-4080W	3	31.9" x 16.5" x 2.8"	66	30	350 lbs.	EEPМ-4080ISP	EEPМ-C2
EEPМ-4090W	3	34.3" x 16.5" x 2.8"	72	30	372 lbs.	EEPМ-4090ISP	EEPМ-C4
EEPМ-40100W	3	39.0" x 16.5" x 2.8"	84	30	425 lbs.	EEPМ-40100ISP	EEPМ-C4
EEPМ-5060W	2	23.2" x 18.9" x 2.8"	56	30	284 lbs.	EEPМ-5060ISP	EEPМ-C2
EEPМ-5080W	3	31.9" x 18.9" x 2.8"	77	30	407 lbs.	EEPМ-5080ISP	EEPМ-C4
EEPМ-5090W	3	34.3" x 18.9" x 2.8"	84	30	431 lbs.	EEPМ-5090ISP	EEPМ-C4
EEPМ-50100W	3	39.0" x 18.9" x 2.8"	98	30	482 lbs.	EEPМ-50100ISP	EEPМ-C4
EEPМ-6060W	2	23.2" x 23.6" x 2.8"	72	30	363 lbs.	EEPМ-6060ISP	EEPМ-C4
EEPМ-6080W	3	31.9" x 23.6" x 2.8"	99	30	473 lbs.	EEPМ-6080ISP	EEPМ-C4
EEPМ-6090W	3	34.3" x 23.6" x 2.8"	108	30	528 lbs.	EEPМ-6090ISP	EEPМ-C4
EEPМ-60100W	3	39.0" x 23.6" x 2.8"	126	30	603 lbs.	EEPМ-60100ISP	EEPМ-C4
EEPМ-8080W	3	31.9" x 29.7" x 2.8"	121	30	596 lbs.	EEPМ-8080ISP	EEPМ-C4

*Subplates are the same dimensions as the chucks, except they are 1" thick (H).

Pole Extensions

Use Pole Extensions For:

- 5-sided machining and thru-hole drilling
- Holding warped or irregularly shaped stock
- Create work-stops for accurate part alignment

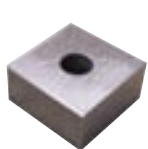
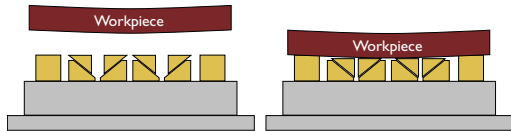

EEPM-S50



EEPM-SP50



EEPM-SPF50



EEPM-SPF50-STOP



Controller is included with chuck.
Order accessories separately.

Item #	Description	L x W x H
EEPM-S50	Fixed, soft induction block (8mm screw)	1.97" x 1.97" x 0.98"
EEPM-SP50	Spring adjusting induction block (2 pcs. set, 8mm screw)	1.92" x 1.81" x 1.81"
EEPM-SPF50	Fixed, soft induction block, use at corners with EEPM-SP50 spring blocks. (8mm screw)	1.97" x 1.97" x 1.65"
EEPM-SPF50-STOP	Fixed, soft induction block with work-stop (rotating) for fast, accurate positioning	1.97" x 1.97" x 1.65"
ECE-TC100	Toggle Clamps for holding non-ferrous materials (set of 2)	6.5" x 2" x 2.5"

Machinable Subplates

Order from page 6:

- Fast, repeatable part positioning
- Great for repeat jobs
- Protects chuck surface

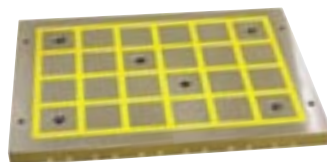

Subplates are sized to match your chuck. See page 6.

Machine part nests in subplate for repeat jobs.

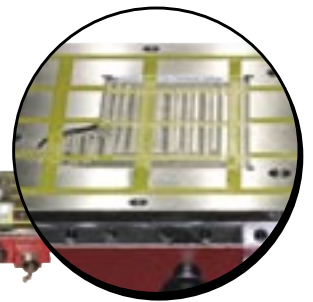

Custom Tombstones

Built to your specifications:

- Gang part setups together
- Fastest setups for pallet systems
- Ideal for work cube process



Call us to discuss your needs:

(800) 597-3921
or local
(317) 803-8000



MagVISE ECB Permanent Magnetic Vises



Features:

- No electricity required
- Modular layout for custom setups
- Spring-loaded induction blocks hold warped stock

Benefits:

- Slash setup and part change over times
- 5-sided machining
- No workpiece deformation
- Improve machining performance

MagVISE Permanent Magnetic Vises slash setup times on horizontal or vertical CNC machine tools. They are used for all types of machining and boring operations on thin to thick workpieces.

No electricity is needed. Turn the magnetic vise "ON" and "OFF" with the turn of a wrench. Our magnetic vises easily integrate with pallet changing and tombstone systems for horizontal and vertical machining centers.

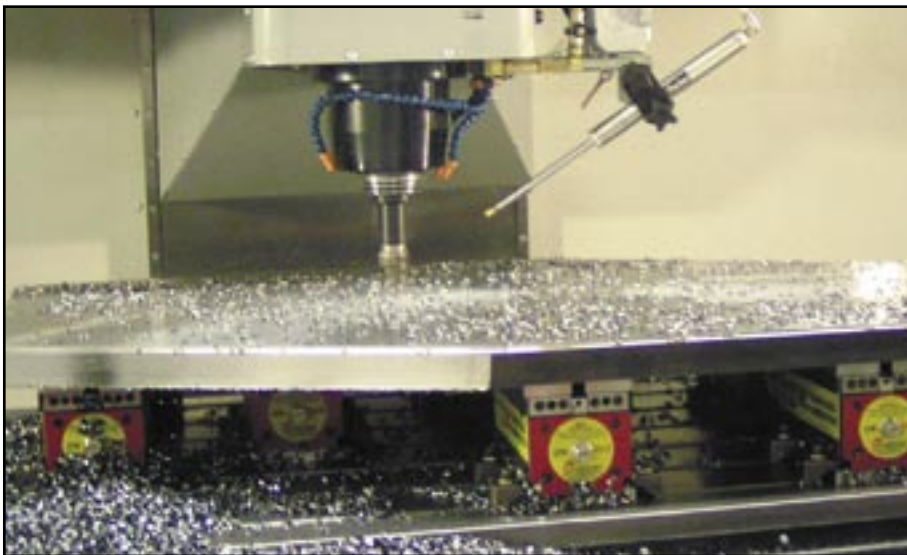

Magnetic workholding provides very even holding of the workpiece, without dead spots, so chatter is reduced while tool life and surface finish are improved. Rough or uneven stock is no problem to hold thanks to spring-loaded induction blocks that adjust to fit the workpiece.

See a short video of the MagVISE Magnetic Vises action on our website: www.technikusa.com

Modular ECB magnetic vises hold irregular stock sizes, warped stock, and large workpieces, without the need for special fixturing.

The Old Way: Modular Fixturing

A) Set It Up, Then Tear It Down

Flexible, but labor intensive setups and tear-downs.

B) Requires Training

Complicated systems require skilled operators.

C) Lost Productivity

Long setup times and can't machine on 5 sides.

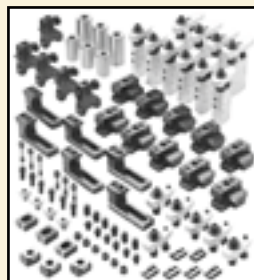

The Earth Chain Way: ECB Magnetic Vises

A) Fast Setups

Position ECB Blocks as needed on your machine bed using toe-clamps.

B) Anyone Can Use It

Fast & simple to use. Layout to fit your workpiece.

C) Increase Productivity

Cut hours of setup-time. Machine 5-sides.



MagVISE ECB Application Examples



Rotary Table



Irregular part setup

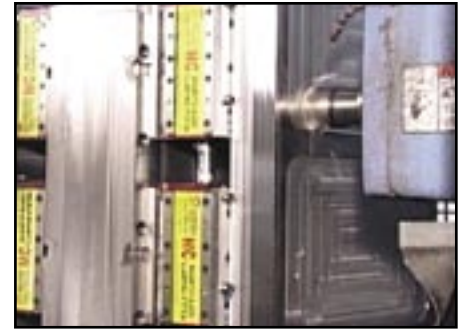

Horizontal machining on a pallet system



Spring-blocks adjust to hold warped stock



Setup for a long and narrow part



Easily handle extra-large workpieces

Ordering MagVISE Permanent Magnetic Vises

Includes 2 machinable induction blocks, wrench, extension and socket, switch-connect socket assembly, 2 stop plates, 4 toe clamps.

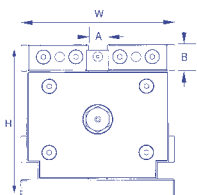

end view

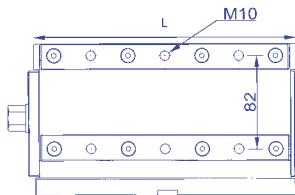

side view

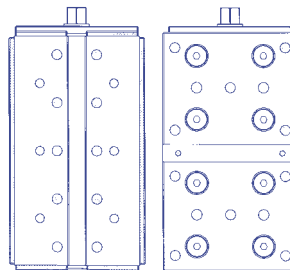

top and bottom view



MagVISE ECB Vise Dimensions

Model	L x W x H	A	B	Min. Stock Thickness	Holding Power	Weight
ECB-050	5" x 3" x 3"	.47"	.47"	0.4"	1,100 lbs.	15 lbs.
ECB-075	6.8" x 3" x 3"	.47"	.47"	0.4"	1,650 lbs.	19 lbs.
ECB-120	7.3" x 4.2" x 4.2"	.62"	.59"	0.6"	2,640 lbs.	40 lbs.
ECB-210	9.2" x 5.2" x 5.3"	.65"	.84"	0.8"	4,620 lbs.	80 lbs.
ECB-SPF50	1, soft fixed induction block, 10mm screw - use with ECB-SP50 spring blocks. Dimensions: 1.97" x 1.97" x 1.65"					
ECB-SP50	2, spring loaded induction block, 10mm screw - use with ECB-SPF50 on corners. Dimensions: 1.89" x 1.81" x 1.89"					
ECE-TC100	Toggle Clamps for holding non-ferrous materials such as aluminum and brass. (set of 2)					

Note: Holding power depends on workpiece size, material, surface finish, contact area with magnet, and workpiece thickness.

EZ-Lift ELM Material Handling Magnets

Smallest, Most Powerful Lifter – With The Best Safety Factor (3.5 X)

Features:

- No electricity required
- Fastest & Safest way to lift
- Lift flat or round stock
- Capacity up to 6,600 lbs., higher with spreader bars

Benefits:

- Safer than straps and slings
- Never needs to be re-certified
- So simple anyone can use it
- Reduces transport and setup time for more productivity

Our customers prefer ELM lifting magnets because they are the smallest, most powerful lifting magnet available with a **3.5X SAFETY FACTOR**. **Our safety factor is the best in the industry.**

ELM lifters feature super-powerful rare-earth neodymium iron boron lifting magnets that require no electricity and have dozens of uses. Load and unload plate, block, or round steel and iron stock. Use them on press molds, machined parts, and other ferrous materials. Use spreader bars to lift large material.



ELM-600
lifts 1,320 lbs.



ELM-100
lifts 220 lbs.

Videos & case-studies at:
www.techniksusa.com



Spreader Bars capacity up to 13,500 lbs.

The Old Way: Material Handling

A) Risk of Injury

Risk of injury to back, fingers, or toes when moving material in order to position sling or chain.

B) Slings & Chains Wear Out

Lifting equipment needs to be recertified and replaced periodically.

C) Lost Productivity

It takes time to properly setup slings or chains to safely move materials.



The Earth Chain Way: ELM Lifting Magnets

A) Safer – 3.5X Safety Factor

Simply center lifting magnet on workpiece to lift.

B) EZ-Lift Lasts Forever

Rare-Earth magnet will never wear out and uses no electricity.

C) Increase Productivity

EZ-Lift is the fastest and safest way to transport raw stock and workpieces.



EZ-Lift Application Examples



Safest way to move ferrous stock.



Use to setup CNC machining centers.



Center magnet on workpiece to lift.



Beveled bottom surface lifts tube steel easily.



Use spreader bars for large or unbalanced loads.



Vertical Lifters can be operated by one person.



Eliminate straps, slings and associated dangers.



Locate magnet at balance point for lifting.

**3.5 X
Safety
Factor** 

Best Safety Factor Available
All our lifting magnets have a safety factor of 3.5 times the rated capacity.

EZ-Lift Operation

Calculate Maximum Load for your stock. Center the magnet on the workpiece. Move lever to the "ON" position to lift. Follow all directions in the Operating Instructions that comes with your magnet.



Lever in the "ON" position. The safety lock is engaged.



Lever in the "OFF" position.

How It Works:

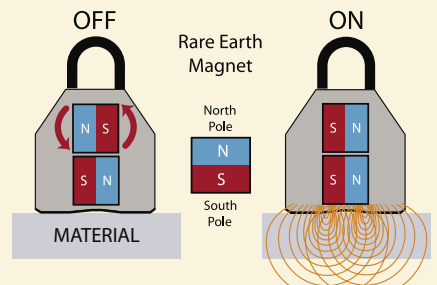

Each ELM lifting magnet contains super powerful rare earth magnets arranged in 3 rows. The OFF position is when the magnetic poles are in alignment as shown (top left).

Turning the lever to the ON position rotates the center row of magnets 180° so the poles alternate, creating a powerful magnetic field.

Never attempt to turn the magnet ON unless it is placed on a correctly sized piece of material to be moved, or you may cause injury to yourself, or the ELM lifting magnet. Always follow all instructions carefully.

EZ-Lift Ordering Information and Rated Capacities – Plate & Round Steel

Model	Plate	Round	A	B	C	D	E	F	G	H	Weight
ELM-100	220 lbs.	99 lbs.	4.2"	3.3"	4.7"	4.9"	2.4"	2.8"	1.6"	1.2"	5.5 lbs.
ELM-300	660 lbs.	300 lbs.	7.1"	6.1"	6.1"	7.3"	3.6"	3.7"	2.0"	1.6"	18.9 lbs.
ELM-600	1,320 lbs.	600 lbs.	10.0"	8.8"	8.3"	10.2"	4.5"	4.7"	3.0"	2.0"	46 lbs.
ELM-1000	2,200 lbs.	990 lbs.	11.0"	9.6"	11.3"	14.6"	6.5"	6.7"	3.8"	3.4"	101 lbs.
ELM-2000	4,400 lbs.	1,980 lbs.	16.6"	15.0"	13.7"	20.2"	8.5"	8.5"	4.1"	4.8"	259 lbs.
ELM-3000	6,600 lbs.	2,970 lbs.	22.3"	20.9"	15.7"	30.3"	8.5"	8.7"	5.8"	3.2"	399 lbs.

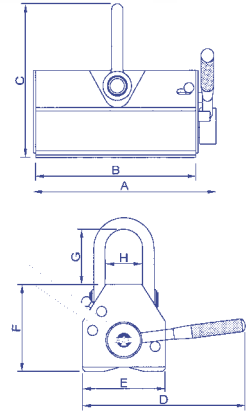

Formula for Calculating Maximum Load by Material Type

$$T \text{ (thickness)} \times F \text{ (finish)} \times M \text{ (material)} \times \text{Capacity} = \text{ML}$$

Example: (ELM-600/plate steel) 2" (T=100%) x F2(100%) x M2 (85%) x 1,320 lbs. = **1,122 lbs.**

M Lifting Power by Material

Carbon Content	Lifting Power (%)		
	0%	50%	100%
M1	Low Carbon	100%	100%
M2	Moderate Carbon	85%	85%
M3	High Carbon	75%	75%
M4	Cast Iron	70%	70%

F Effect of Surface Finish

Surface Finish	Lifting Power (%)			
	0%	50%	100%	150%
F1	▽▽▽ Ground Surface	125%	125%	125%
F2	▽▽ Rough Machined	100%	100%	100%
F3	▽ Foundry Finish	90%	90%	90%
F4	~ Rough Cast	65%	65%	65%

Calculating Maximum Loads

Calculate that the magnet will safely lift your material. Maximum Load (ML) is different for plate and round materials, and also depends upon stock thickness, carbon content, and surface finish. Use the formula and tables to calculate ML for your material type.

Rated Capacity

Model	Plate Steel*
ELM-100	220 lbs.
ELM-300	660 lbs.
ELM-600	1,320 lbs.
ELM-1000	2,200 lbs.
ELM-2000	4,400 lbs.
ELM-3000	6,600 lbs.
Model	Round Steel*
ELM-100	99 lbs.
ELM-300	300 lbs.
ELM-600	600 lbs.
ELM-1000	990 lbs.
ELM-2000	1,980 lbs.
ELM-3000	2,970 lbs.

T Equals Percent of Lifting Power by T (thickness)

T	ELM-100	ELM-300	ELM-600	ELM-1000	ELM-2000	ELM-3000
2 3/8" (60mm)	100%	100%	100%	100%	100%	100%
2 1/8" (55mm)	100%	100%	100%	100%	100%	95%
2.0" (50mm)	100%	100%	100%	100%	95%	90%
1 3/4" (45mm)	100%	100%	100%	100%	90%	85%
1 1/2" (40mm)	100%	100%	100%	100%	85%	80%
1 3/8" (35mm)	100%	100%	100%	90%	75%	70%
1 1/8" (30mm)	100%	100%	100%	80%	65%	60%
1.0" (25mm)	100%	100%	90%	70%	55%	50%
3/4" (20mm)	100%	90%	75%	60%	45%	40%
1/2" (15mm)	100%	70%	60%	50%	35%	30%
3/8" (10mm)	70%	50%	45%	35%	25%	20%
1/4" (5mm)	40%	30%	25%	20%	15%	10%

*Follow all directions in the Operating Instructions that comes with your magnet.



EZ-Lift Spreader Bars

- For better overall balance
- Use with multiple lifters
- Lifter span adjustable

Keeps large materials balanced for safer transport.

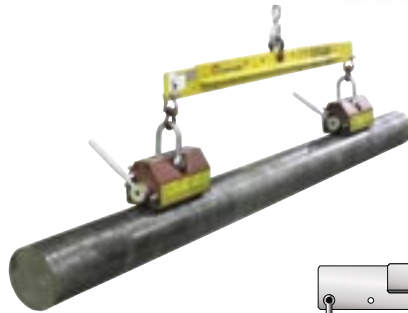

Control large or irregular loads during transport. Increase lifting power by adding more magnets. Includes bar, 1 upper and 2 lower S.P.A. shackles. Order magnets separately.

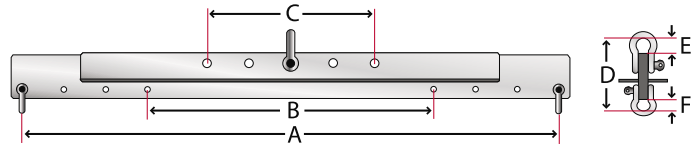

Model	Capacity	A	B	C	D	E	F	Weight
ELM-SB250	250 lbs.	36"	18"	12"	5.1"	1.25"	.85"	20 lbs.
ELM-SB500	500 lbs.	46"	22"	16"	5.7"	1.35"	1.34"	25 lbs.
ELM-SB1000	1,000 lbs.	72"	36"	24"	6.9"	1.35"	1.34"	65 lbs.
ELM-SB2000	2,000 lbs.	72"	36"	24"	7.3"	2.02"	1.35"	115 lbs.
ELM-SB4000	4,000 lbs.	77"	41"	24"	10.5"	2.43"	1.63"	195 lbs.
ELM-SB8000	8,000 lbs.	96"	48"	24"	12.3"	2.94"	1.78"	300 lbs.
ELM-SB10000	10,000 lbs.	116"	56"	24"	14.7"	3.5"	1.65"	600 lbs.
ELM-SB13500	13,500 lbs.	140"	68"	36"	17.1"	4.0"	2.02"	880 lbs.

EZ-Lift Vertical Lifters

- Fast loading for vertical transport
- One person can load and unload
- No dangerous straps & slings



Used for vertical transport of plate stock. Includes ELM lifting magnet.



Position lifter on stock and turn the lever to the on position. Hoist into vertical position for transport. Always follow operating instructions included.

Model	Size L x W x H	Capacity	Weight	Plate Size L x W x H (min/max)		
				L	W	H
ELM-300V	37.5" x 8.5" x 10"	660 lbs.	57 lbs.	8"/60"	11.8"/31.5"	0.25"/5.9"
ELM-600V	46" x 11" x 10"	1,320 lbs.	86 lbs.	12"/72"	11.8"/39.4"	0.31"/9.8"
ELM-1000V	48" x 14" x 12"	2,200 lbs.	128 lbs.	12.5"/79"	11.8"/39.4"	0.39"/11.8"

EZ-Lift Magnetic Separators

- Separates sheet stock for easy transport
- Great for press-brakes or sheet feeders
- Makes separating oily or stuck sheets easy

Separates iron or steel sheets for easy feeding into automatic sheet feeding equipment or for manual transport. Will separate irregularly shaped material. Sold in pairs.

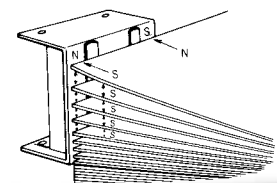
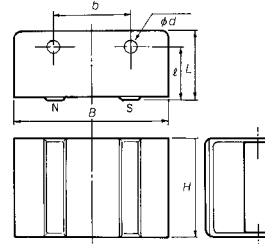

Model	B	H	L	I	d	b	Maximum Thickness
EF-10	133	87	61	51	8	56	2.0mm
EF-20	136	127.5	61	51	8	80	3.2mm
EF-40	215	251	75	60	11	150	3.2mm

Surface Grinding – Magnetic Chucks

EDMT and EDTW Permanent Magnetic Chucks:

- EDM-READY: fully submersible, brass welded faceplate
- Powerful Rare Earth Neodymium Iron Boron magnets are 5 times stronger than other magnets
- Low-profile design increases Z-axis stroke
- Demagnetizers on page 18



Variable pole design EDMT chucks.

EDMT (All-Purpose Variable Pole Design)

Alternating thick/thin magnetic poles provides best holding power for both thick and thin workpieces.

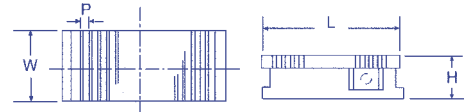

Model	Pole Pitch (P)	L x W x H	Weight
EDMT-1018	11.2 (1.6+2+1.6+6)	7" x 4" x 2.5"	16 lbs
EDMT-1325	11.2 (1.6+2+1.6+6)	10" x 5" x 2.5"	23 lbs
EDMT-1530	11.2 (1.6+2+1.6+6)	12" x 6" x 2.5"	33 lbs
EDMT-1535	11.2 (1.6+2+1.6+6)	14" x 6" x 2.5"	38 lbs
EDMT-1545	11.2 (1.6+2+1.6+6)	18" x 6" x 2.5"	44 lbs
EDMT-2040	11.2 (1.6+2+1.6+6)	16" x 8" x 2.5"	57 lbs
EDMT-2045	11.2 (1.6+2+1.6+6)	18" x 8" x 2.5"	66 lbs
EDMT-2050	11.2 (1.6+2+1.6+6)	20" x 8" x 2.5"	79 lbs
EDMT-2550	4 + 12	20" x 10" x 2.5"	130 lbs
EDMT-3060	3 + 15	24" x 12" x 2.5"	198 lbs

Variable Pole

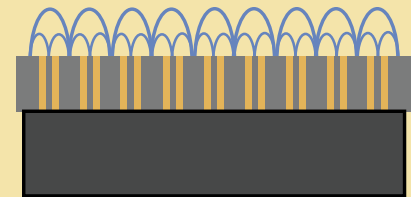

*New variable pole design creates magnetic fields that hold both thin and thick workpieces equally well.

Fine Pole

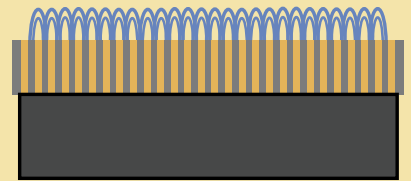

Fine pole array creates strongest magnetic field close to surface for holding thin workpieces.

EDTW Fine Pole:

Fine pole design provides best holding power on workpieces over 2mm thick.



Model	Pole Pitch (P)	L x W x H	Weight
EDTW-1018	2 (1+1)	7" x 4" x 2"	15 lbs.
EDTW-1325	2 (1+1)	10" x 5" x 2.25"	29 lbs.
EDTW-1515	2 (1+1)	6" x 6" x 2.25"	20 lbs.
EDTW-1530	2 (1+1)	12" x 6" x 2.5"	49 lbs.
EDTW-1535	2 (1+1)	14" x 6" x 2.5"	53 lbs.
EDTW-1545	2 (1+1)	18" x 6" x 2.5"	68 lbs.
EDTW-2040	2 (1+1)	16" x 8" x 2.5"	82 lbs.
EDTW-2045	2 (1+1)	18" x 8" x 2.5"	90 lbs.
EDTW-2050	2 (1+1)	20" x 8" x 2.5"	99 lbs.
EDTW-2550	2 (1+1)	20" x 10" x 2.5"	132 lbs.

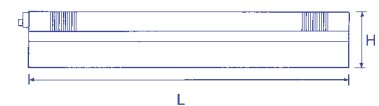
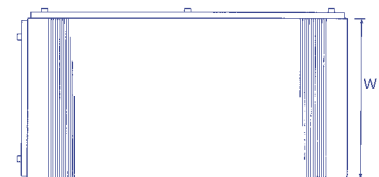

EDTW chucks have up to 15 tons of holding force. (150 lbs./inch²)

Surface Grinding – Electromagnetic Chucks

EET Electromagnetic Chucks:

- EDM-READY: fully submersible, brass sealed
- Hard soldered top plate and solid bottom plate for maximum rigidity and accuracy
- Strong magnetic force regulated by controller

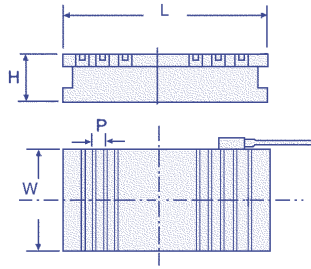

See page 18 for chuck controllers

Model	Pole Pitch (P)	L x W x H	Volts	Amps	Weight
EET-1530	15 (3+12)	12" x 6" x 3"	DC90V	0.18	44 lbs.
EET-1535	15 (3+12)	14" x 6" x 3"	DC90V	0.19	53 lbs.
EET-1545	15 (3+12)	18" x 6" x 3"	DC90V	0.19	66 lbs.
EET-2040	15 (3+12)	16" x 8" x 3"	DC90V	0.28	84 lbs.
EET-2045	15 (3+12)	18" x 8" x 3"	DC90V	0.28	90 lbs.
EET-2050	15 (3+12)	20" x 8" x 3"	DC90V	0.36	99 lbs.
EET-2550	15 (3+12)	20" x 10" x 3"	DC90V	0.46	143 lbs.
EET-3060	15 (3+12)	24" x 12" x 3"	DC90V	0.86	179 lbs.
EET-3070	15 (3+12)	28" x 12" x 3"	DC90V	0.81	205 lbs.
EET-3090	15 (3+12)	35" x 12" x 3"	DC90V	1.05	276 lbs.
EET-4060	19 (3+16)	24" x 16" x 3.5"	DC90V	0.95	287 lbs.
EET-4070	19 (3+16)	28" x 16" x 3.5"	DC90V	1.21	333 lbs.
EET-4080	19 (3+16)	32" x 16" x 3.5"	DC90V	1.31	384 lbs.
EET-40100	19 (3+16)	40" x 16" x 3.5"	DC90V	1.33	487 lbs.
EET-50100	19 (3+16)	40" x 20" x 3.5"	DC90V	1.46	595 lbs.
EET-50150	19 (3+16)	60" x 20" x 3.5"	DC90V	3.37	893 lbs.
EET-60100	19 (3+16)	40" x 24" x 3.5"	DC90V	2.80	728 lbs.
EET-60150	19 (3+16)	60" x 24" x 3.5"	DC90V	2.85	1091 lbs.
EET-80100	19 (3+16)	40" x 32" x 3.5"	DC90V	3.80	970 lbs.

EET-W Fine Pole Electromagnetic Chuck:

- Fine pole design provides best holding power on workpieces over 2mm thick

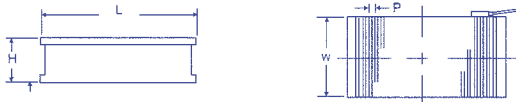

Model	Pole Pitch (P)	L x W x H	Volts	Amps	Weight
EET-1530W	4(1+3)	12" x 6" x 4.5"	DC90V	0.73	73 lbs.
EET-1535W	4(1+3)	14" x 6" x 4.5"	DC90V	0.61	88 lbs.
EET-1545W	4(1+3)	18" x 6" x 4.5"	DC90V	0.98	110 lbs.
EET-2040W	4(1+3)	16" x 8" x 4.5"	DC90V	1.10	139 lbs.
EET-2045W	4(1+3)	18" x 8" x 4.5"	DC90V	1.20	157 lbs.
EET-2050W	4(1+3)	20" x 8" x 4.5"	DC90V	1.40	176 lbs.
EET-2550W	4(1+3)	20" x 10" x 4.5"	DC90V	1.00	247 lbs.
EET-3060W	4(1+3)	24" x 12" x 4.5"	DC90V	1.50	331 lbs.

Surface Grinding - Electromagnetic Chucks

EET-WL Fine Pole - Lengthwise

- Brass welding protects faceplate from coolant corrosion

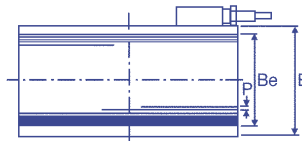
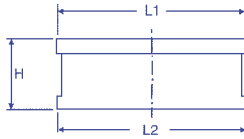

Model	L x W x H	B	Face Plate		Pole Pitch (P)	Current		Weight
			L1	Be		Amp/DCV		
EET-1530WL	12" x 6" x 4"	150mm	300mm	125mm	4(1+3)	.39/90		42 lbs.
EET-1535WL	14" x 6" x 4"	150mm	350mm	125mm	4(1+3)	.52/90		51 lbs.
EET-1545WL	18" x 6" x 4"	150mm	450mm	125mm	4(1+3)	.60/90		64 lbs.
EET-2040WL	16" x 8" x 4"	200mm	400mm	173mm	4(1+3)	.69/90		75 lbs.
EET-2045WL	18" x 8" x 4"	200mm	450mm	173mm	4(1+3)	.90/90		84 lbs.
EET-2050WL	20" x 8" x 4"	200mm	500mm	173mm	4(1+3)	1.01/90		93 lbs.
EET-2060WL	24" x 8" x 4"	200mm	600mm	173mm	4(1+3)	1.31/90		112 lbs.
EET-2540WL	16" x 10" x 4"	250mm	400mm	225mm	4(1+3)	1.00/90		112 lbs.
EET-2545WL	18" x 10" x 4"	250mm	450mm	225mm	4(1+3)	1.10/90		123 lbs.
EET-2550WL	20" x 10" x 4"	250mm	500mm	225mm	4(1+3)	1.33/90		137 lbs.
EET-3060WL	24" x 12" x 4"	300mm	600mm	273mm	4(1+3)	1.52/90		216 lbs.

EET-Z Super Power Pole

- Specially designed for heavy cutting.
- For work pieces 0.5" or thicker

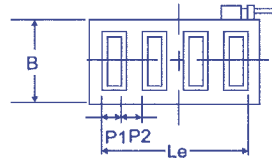
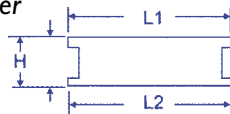

Model	L x W x H	B	Face Plate		Pole Pitch (P)		Current		Weight
			L1	Le	P1	P2	Amp/DCV		
EET-2050Z	20" x 8" x 5"	200mm	500mm	442mm	34	33	1.40/90		170 lbs.
EET-2060Z	24" x 8" x 5"	200mm	600mm	546mm	36	36	1.70/90		207 lbs.
EET-2080Z	32" x 8" x 5"	200mm	800mm	741mm	35	35	2.30/90		275 lbs.
EET-2550Z	20" x 10" x 5"	250mm	500mm	442mm	34	33	1.80/90		216 lbs.
EET-2560Z	24" x 10" x 5"	250mm	600mm	546mm	36	36	2.10/90		258 lbs.
EET-3060Z	24" x 12" x 5"	300mm	600mm	546mm	36	36	2.60/90		308 lbs.
EET-3090Z	35" x 12" x 5"	300mm	900mm	840mm	35	35	4.00/90		462 lbs.
EET-4080Z	32" x 16" x 5"	400mm	800mm	741mm	35	35	4.70/90		551 lbs.
EET-40100Z	40" x 16" x 5"	400mm	1000mm	938mm	35	34	5.80/90		695 lbs.
EET-50100Z	40" x 20" x 5"	500mm	1000mm	938mm	35	34	7.20/90		882 lbs.
EET-50150Z	60" x 20" x 5"	500mm	1500mm	1430mm	37	36	9.00/90		1,323 lbs.
EET-60100Z	40" x 24" x 5"	600mm	1000mm	938mm	35	34	8.00/90		1,058 lbs.
EET-60150Z	60" x 24" x 5"	600mm	1500mm	1430mm	37	36	10.1/90		1,620 lbs.

Surface Grinding Chuck Induction Blocks

EHT Induction Blocks:

- Extends magnetic force to hold bar, round, or irregular shapes
- EDM-READY: fully submersible, brass sealed
- For fine-pole and standard pole applications
- Choose from lengthwise (L) or width-wise (W) pole direction
- For permanent and/or electromagnetic chucks

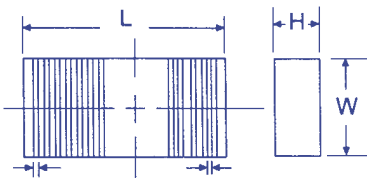

EHT-100
(set of 2)

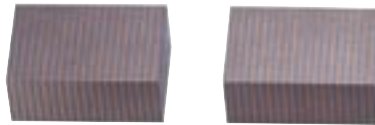

EHT-150W

EHT-72
(set of 2)



EHT-150L

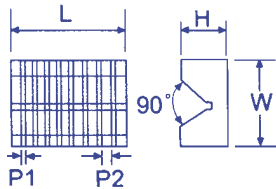

EHT-65V
(set of 2)



EHT-150



EHT-300W (fine pole)



EHT-300L (lengthwise pole)



EHT-300 (width-wise pole)

Model	Qty.	L x W x H	Pole Pitch P1	Pole Pitch P2	Weight
EHT-65V	2	2.5" x 2.5" x 1.5"	2	3	4 lbs. (x2)
EHT-72	2	3" x 2" x 1"	2	3	7 lbs. (x2)
EHT-100	2	4" x 3" x 1.5"	2	3	10 lbs. (x2)
EHT-150	1	6" x 3" x 1"	2	3	5 lbs.
EHT-300	1	12" x 3" x 1"	2	3	10 lbs.
EHT-150L	1	6" x 3" x 1"	2	3	5 lbs.
EHT-300L	1	12" x 3" x 1"	2	3	10 lbs.
EHT-150W	1	6" x 3" x 1"	1+1	1+1	5 lbs.
EHT-300W	1	12" x 3" x 1"	1+1	1+1	10 lbs.

Grinding Chuck Controllers – Demagnetizers

ERD-505, 510, 515 Features:

- Work with any electromagnetic chucks
- Demagnetizing time is 6-15 seconds
- Precisely regulates the magnetic force

ERD-520 Features:

- For larger, more powerful electromagnetic chucks
- Can operate two chucks at the same time
- Demagnetizing time is 8-15 seconds



ERD-505



ERD-510, ERD-515



ERD-520

Model	Input Voltage/Single Phase	Output Volts	Output Amps	Dim. L x W x H	Weight
ERD-505	AC 110/220V	DC 0-100V	5A	8" x 5.5" x 5"	8 lbs.
ERD-510	AC 110/220/440V	DC 0-120V	10A	6" x 13" x 10"	33 lbs.
ERD-515	AC 220/440V	DC 0-120V	15A	6" x 13" x 10"	44 lbs.
ERD-520	AC 220/440V	DC 0-120V	20A	7" x 15" x 12"	71 lbs.

Please specify voltage when ordering.

EDH Demagnetizers



EDH-123



EDH-180



EDH-200

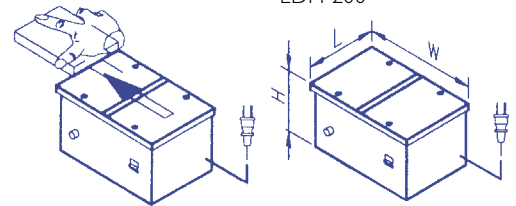
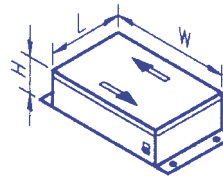
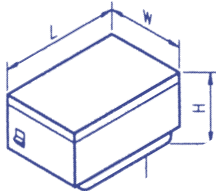

Model	Description	Power	Capacity	Duty Cycle	Dim. L x W x H	Weight
EDH-123	Portable, light weight, use on big machines	AC 110V	110VA	90%	123 x 83 x 83mm	4 lbs.
EDB-180	For up to 20 minutes continuous operation	AC 110/220V	220VA	50%	127 x 180 x 90mm	9 lbs.
EDS-200	For continuous operation, double-coil design	AC 110V	330VA	100%	150 x 200 x 100mm	19 lbs.

Magnetic Square and V-Blocks

ECE Magnetic Blocks

- Dozens of uses around the shop
- Fast setups of bar stock or round steel
- Powerful magnetic base, ON-OFF switch

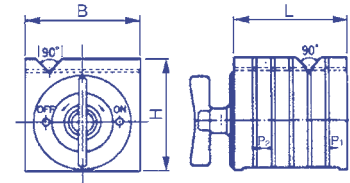

ECE-100 / ECE-150

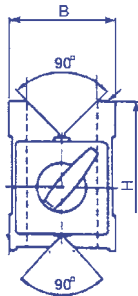

ECE-208 / ECE-212

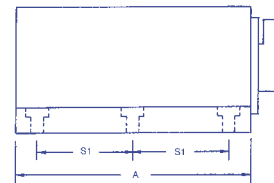

ECE-612

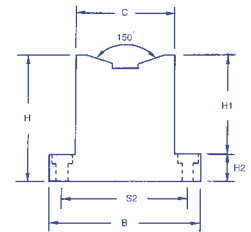

Model	Holding Power		Dimensions mm								
	V-Face	Surface	B	L	H	C	H1	H2	S1	S2	Weight
ECE-100	61 lbs.	88 lbs.	100	100	100	-	-	-	-	-	14.5 lbs.
ECE-150	110 lbs.	308 lbs.	150	150	150	-	-	-	-	-	53 lbs.
ECE-208	121 lbs.	154 lbs.	56	80	72	-	-	-	-	-	6.5 lbs.
ECE-212	198 lbs.	242 lbs.	75	115	100	-	-	-	-	-	11 lbs.
ECE-612	242 lbs.	350 lbs.	76	118	62	50	50	12	48	62	5.5 lbs.

ECE Magnetic V-Block Sets

- For grinding, marking, measuring and other light machining operations
- Each pair made to identical dimensions
- Sold in pairs only



ECE-507



ECE-510

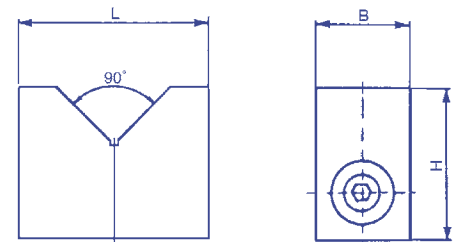

Model	Holding Power	Applicable Diameter mm	Dimension mm				Weight
			B	L	H	Weight	
ECE-507	33 lbs.	50	40	72	50	2.2 lbs. x 2	
ECE-510	44 lbs.	80	50	100	80	6.6 lbs. x 2	

sPINner Magnetic Deburring Machine

Tough & reliable, the sPINner is KING of small precision parts deburring!

Applications

- medical parts - swiss turned
- drilled or threaded parts
- machined or stamped parts

Benefits

- costs less than hand deburring
- deburr parts faster & better
- improve quality of parts
- see case studies on our website!



See actual sPINner case-studies at: www.techniksusa.com

The Old Way: Deburring Parts

A) Time Consuming

Hand deburring is labor intensive and time consuming process

B) Production Bottleneck

Deburring often limits how productive you can be

C) Expensive

Deburring requires expensive manual labor driving costs up



The Earth Chain Way: sPINner Deburring

A) Deburr Faster & Better

Improve part quality and get more consistent results

B) Speeds Production

Batch deburr dozens, hundreds, or thousands of parts in minutes

C) Reduce Costs

Eliminate expensive hand deburring and increase production



Batch Deburr Small, Precision Parts

Send us your parts for a free deburring analysis!

The sPINner works best on small, precision parts, made from non-ferrous metals including: aluminum, brass, copper, stainless steel, and titanium. The deburring process will not affect tolerances or damage delicate parts.

Send your parts to:
Earth Chain / Deburring
9930 East 56th St.,
Indianapolis, IN 46236



Typical Deburred Parts



The sPINner deburrs these part features

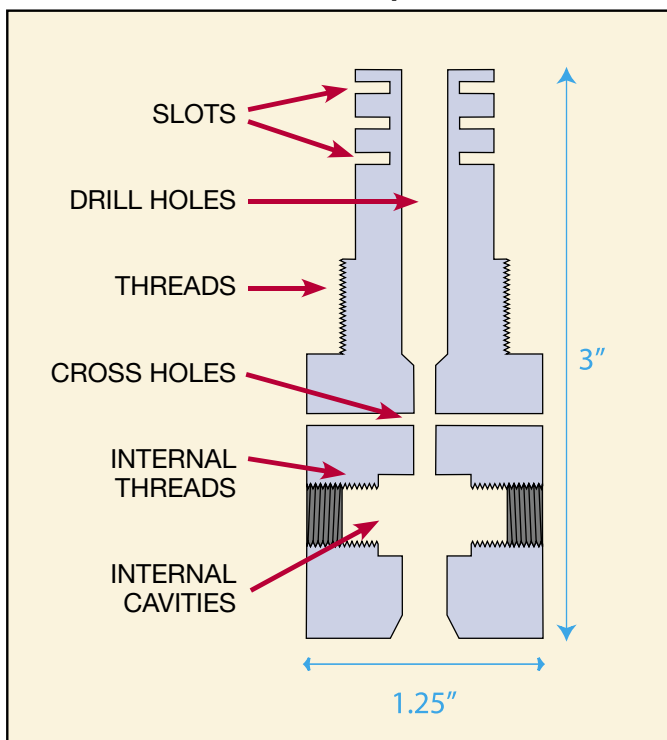

Medical Application



The sPINner is used in many industries including medical, aerospace, and electronics. It is also a good fit for most parts made on CNC Swiss-type lathes.

Aluminum Gear Application

Burrs and rough edges. Deburred part in only 10 minutes. Part Dimensions: 1 9/16" diameter x 5/16" high.

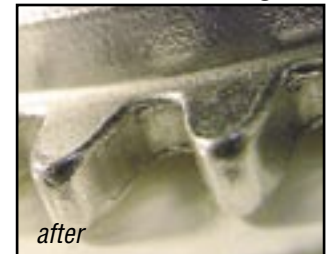

Complex Turned & Machined Aluminum

Burrs on O.D. and in I.D. slots. Batch deburring in only 10 minutes! Part Dim.: 3/16" diameter x 1 3/16" long.



0.01" Diameter Slot in Light Alloy Collar

Fine burrs in hard-to-reach slotted area. Eliminated part quality problem and saved labor costs. Part Dimensions: 1 7/32" diameter x 1/8" high.

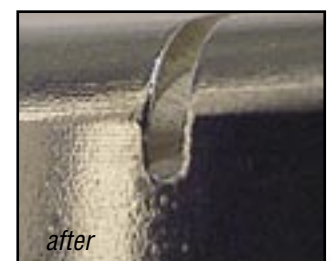

EHD sPINner Machines

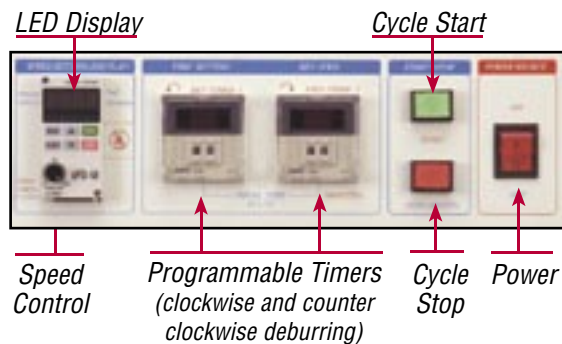

You can increase or decrease the power using the programmable control, or by selecting larger or smaller media. Parts are demagnetized at the end of the deburring cycle.

Model No.	Dim. L x W x H	Tank Size L x W	Power	Amps	Weight
EHD-728	19" x 19" x 37"	11" x 11"	220V	5	160 lbs.
EHD-735	23" x 26" x 34"	15" x 16"	220V	10	220 lbs.
EHD-750	29" x 30" x 36"	21" x 23"	220V	15	385 lbs.

All power requirements are single phase.
Includes: 2 deburring containers, 1 separating container, and 1 manual.
Media and deburring solution sold separately.

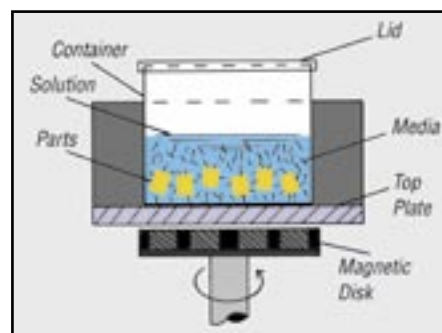

The only moving part is the magnetic disk!

Stainless Steel Pin Media (SUS 304 with magnetic treatment)

This special stainless steel media is hardened to HRC 30, and will last for years in most applications. To deburr hard materials like stainless steel, steel, etc., use a diameter of media bigger than 0.5mm. Use sizes less than 0.5mm for soft material like brass, copper, aluminum, gold, etc. Choose larger pins for harder material and/or to increase deburring power.

If you want to deburr small holes, choose a diameter of pin media that is smaller than the hole. 3mm length media will work better for small holes and crevices.



Standard Dimension Media (diameter x length in millimeters)									
Part No.	EHD-S1	EHD-S2	EHD-S3	EHD-S4	EHD-S5	EHD-S6	EHD-S7	EHD-S8	EHD-S9
Size (mm)	0.2X5mm	0.3x5mm	0.4x5mm	0.5x5mm	0.7x5mm	0.8x5mm	1.0x5mm	1.2x5mm	1.5x5mm

Special Dimension Media (diameter x length in millimeters)									
Part No.	EHD-P1	EHD-P2	EHD-P3	EHD-P4	EHD-P5	EHD-P6	EHD-P7	EHD-P8	
Size (mm)	0.3X3mm	0.4x3mm	0.5x1mm	0.5x3mm	0.7x3mm	0.8x3mm	1.0x1mm	1.0x3mm	



Deburring Solution

Used with all types of materials. Dilute to a 50:1 ratio with water. Other solutions may be used, call for recommendations.

Model No.	Description
PFS-747	1/2 gallon deburring solution
PFS-7475G	5 gallons deburring solution

"One Twist" Indicator Arms (hydraulic and mechanical)



ECE Indicator Arms Features:

- "One Twist" 360° adjustable joints
- Check concentricity on bench or your machine
- Powerful magnetic base

Advantages of Hydraulic Arms

- Hydraulic arms are faster, stronger, and more precise than mechanical joints
- Hydraulic joints make fine adjustments easy because they don't lose position when loosened like mechanical arms



Indicator Arms are used to check concentricity on bench or machine. Dial Indicators not included.



ECE-300 series



ECE-330 series



ECE-340

Part No.	Description	Arm Length	Base Dim. L x W x H	Holding Power	Weight lb
ECE-300ALL	Precision hydraulic arm, gold	23 1/2"	4 3/4" x 2" x 2 1/8"	352 lbs.	7.75
ECE-300AL	Precision hydraulic arm, gold	16 3/4"	3 1/8" x 2" x 2 1/8"	220 lbs.	5.5
ECE-300B	Precision hydraulic arm, gold	13 3/8"	2 3/8" x 2" x 2 1/8"	176 lbs.	4.5
ECE-330AL	Precision mechanical arm, red	16 3/4"	3 1/8" x 2" x 2 1/8"	220 lbs.	5.0
ECE-330B	Precision mechanical arm, red	13 3/8"	2 3/8" x 2" x 2 1/8"	176 lbs.	3.75
ECE-340	Standard mechanical arm, red	13 3/8"	2 3/8" x 2" x 2 1/8"	176 lbs.	3.5

EZ-Lift Magnets & MagVISE Workholding

Load it & hold it faster and safer the "Earth Chain Way"

Quickly load and setup your workpiece

Use EZ-Lift, lifting magnets with MagVISE EEPM magnetic workholding chucks or ECB magnetic vises to significantly reduce material transport and workpiece set-up times.

Powerful and reliable

Both EZ-Lift magnetic lifters and MagVise magnetic vises turn on and off with a simple turn of a lever. Super-powerful neodymium iron boron magnets require no electricity and will never wear out.

Custom workholding fast

Use MagVISE magnetic vises to easily create custom workholding for large jobs and/or multiple workpieces.

You can machine all 5-sides

It's easy to perform complex 5-sided machining using the MagVise Vises or Electro-Permanent Chucks.



Call toll-free (800) 597-3921 Fax: (317) 803-8001
See all our products online at: www.techniksusa.com

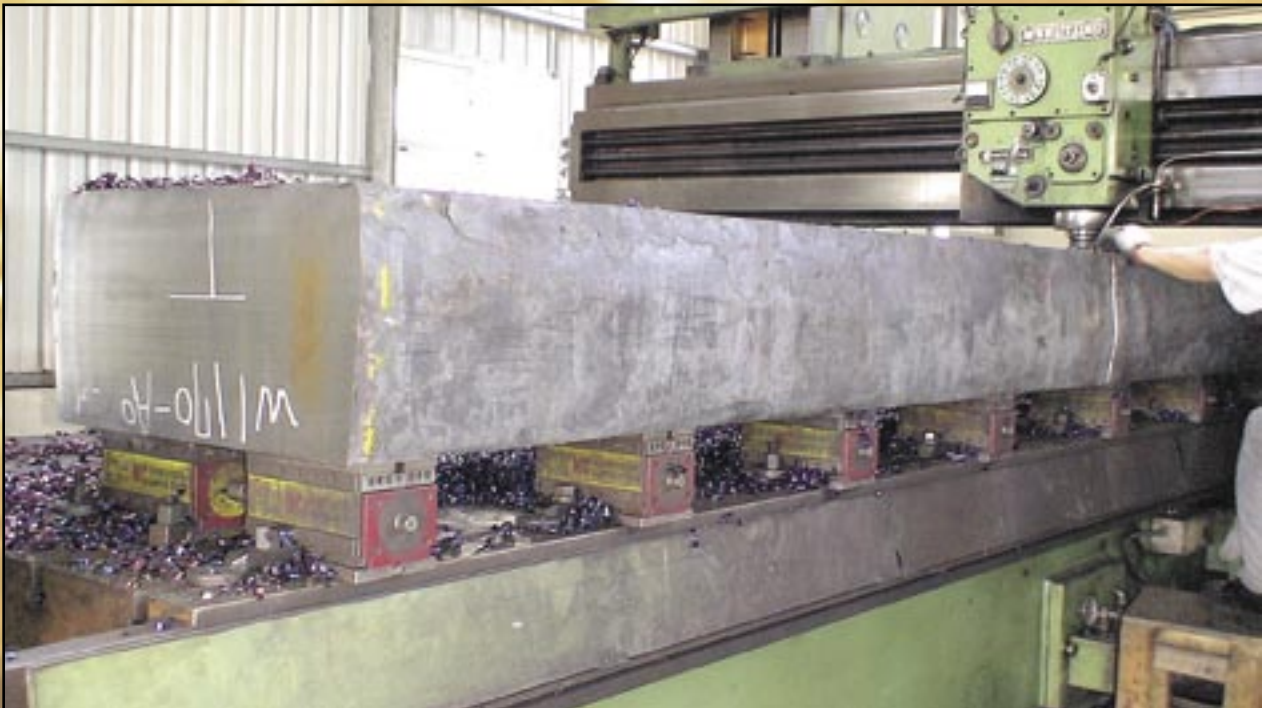

© Copyright 2009 Techniks, Inc. Indianapolis Indiana USA Non-copywritable materials are owned by their authors and are used for illustration purposes only.