

GATOR CHUCKS, KEEPING MACHINE SHOPS RUNNING FOR OVER 30 YEARS

# AHB

TOOLING & MACHINERY

COMPLETE METALWORKING SOLUTIONS

(800) 991-4225

[www.ahbinc.com](http://www.ahbinc.com)

ISO Certified

[customerservice@ahbinc.com](mailto:customerservice@ahbinc.com)



**gator chucks™**  
BY FUERDA



 global tooling  
SOLUTIONS

DIN ▶ ANSI ▶ ISO  
standards

2013 CATALOG

G0713



Global Tooling Solutions is your one stop shop for quality Machine Tool Accessories. We are the authorized supplier for **gator Lathe Chucks** in the United States and Latin America.

Our products and services are designed for the metal working manufacturer and where ever high tolerance machining and product durability are necessary and valued. Our products are channeled to our manufacturer customers through the industry's most reputable Industrial and Metal Working Distributors.

Our customers can expect unbeatable value where quality products, quality service and competitive pricing are difference makers for your business.

**gator** is a world class producer of manual Lathe Chucks with over 30 years of manufacturing experience and production excellence. Steel and Semi-Steel bodies in 2, 3, 4 & 6 Jaw Scroll executions along with 4 Jaw Independent chucks give you a comprehensive lathe chuck offering. A, D, DIN, Land Threaded adapters give you one stop shop capabilities. Both scroll and independent chucks are also available in direct mount applications.

Our state of the art, ISO 9001-2000 manufacturing facility is quality focused...we stand behind our products. Gator chucks are built to last and are designed for precision machining applications.

## TERMS & CONDITIONS

**MINIMUM ORDER:** \$75.00 net.

**PRICING:** Subject to change without notice

**DELIVERY:** All deliveries are F.O.B. Norwood Massachusetts warehouse.

**RETURNS:** A Return Authorization Number (RMA#) is required prior to returning any product.

New product returns must be made within 30 days of original shipment. C.O.D. returns cannot be accepted at our Facility so please do not ship returns C.O.D. as they will be refused. Enclose a copy of the RMA# and a copy of our Invoice or packing slip with your return. Be sure to include any manuals and/or certifications and pack returns in original packaging. Pack well to avoid damage. Failure to adhere to these requirements can result in rejection of the return or credit reduction. All other returns are subject to a 15% restocking fee.

**SHIPMENT ERRORS:** Any shortages or discrepancies in shipment must be reported within 48 hours of receipt.

**DAMAGED SHIPMENTS:** Inspect all merchandise while the driver is present and make notes of visible damages and discrepancies. Contact your local office for UPS, FedEx, and truck shipments and file a report immediately. Keep all damaged goods in the original packaging for inspection. Do not discard any packing materials. Failure to take these actions might waive your claim. Notify us as we will be glad to assist you with your claim.

## LIMITED WARRANTY

**GATOR** - All tools are warranted against manufacturer defects and workmanship under normal use (single shift) according to the proper chuck application (listed in Gator chuck manual) for one year from date of purchase. Steel Body Chucks in PA, PO and PSL groups ONLY are warranted for two years from date of purchase. During warranty Period, we will repair or replace defective items. Modifications to items, normal wear and tear, and consumable items are not covered by this warranty.

The company purchasing and using this Gator Chuck is responsible for ensuring that all personnel operating or servicing the lathe chuck read and understand the Gator Chuck Manual.

Chuck defects must be reported immediately to Global Tooling Solutions in order to limit the extent of damage and to avoid compromising the safety of the chuck. Failure to comply with this instruction will void the warranty.

# Contents



**Tech-Tru™**

9-14

Pages

PA Series Steel Body Adjustable Scroll Chucks



15-19

Pages

PO Series Precision Steel Body Self-Centering Scroll Chucks



20-28

Pages

PS Series Universal Self-Centering Scroll Chucks  
PO/PS Series Front Mount Chucks



29  
Page



30  
Page



36  
Page

PSL Series Large Thru-Hole 3-Jaw Scroll Medium Duty  
and PEO series Heavy Duty Chucks



31-35  
Pages

PI Series 4-Jaw independent Medium Duty and PEI Heavy Duty Chucks



37-38  
Pages

EA Series Semi-Steel Body Adjustable Scroll Chucks

# Chuck Selection Guide

## Determining the Proper Spindle Type and Size

Gator Chucks meet all of the requirements of ASA Standard B5.9-1960.

For spindle nose accuracy (T.I.R) see page 7.

### Selecting the chuck mounting:

- ➔ Choose from the types shown below.
- ➔ For short taper spindle noses Type A, D, & C (DIN), measure the pilot diameter and length (B & C), bolt circle diameter (dimensions F1 & F2) and diameter of the holes (dimensions E1 & E2).
- ➔ In the case of A type mount, check the number of bolt circles (A2 mount or A1 mount).
- ➔ All chucks with A1 mount can be installed on A1 spindle nose only.
- ➔ All chucks with A2 mount can be installed on either A1 or A2 spindle nose.
- ➔ For the long taper spindle noses Type L, check pilot diameter, length and thread size (A, C & B).
- ➔ For the threaded spindle noses, check the thread diameter, number of threads per inch and length (dimensions B & D), plus overall length (dimension F1).

### ➔ Spindle Type A1&A2

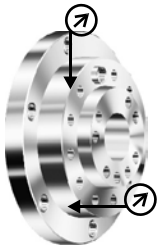
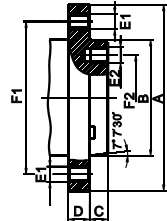

Type A1 has tapped holes on both inner and outer bolt circles.

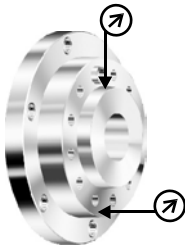

Type A2 does not have holes in the inner bolt circles.

Spindle Nose	F1	F2	B	C max.	Thread E1=E2 UNC-3B
A-4	3.2500	-	2.5005+.0005	.4375	7/16-14
A-5	4.1250	2.4374	3.2505+.0005	.5625	7/16-14
A-6	5.2500	3.2500	4.1880+.0005	.6250	1/2-13
A-8	6.7500	4.3750	5.50075+.0005	.6875	5/8-11
A-11	9.2500	6.5000	7.75075+.0005	.7500	3/4-10
A-15	13.0000	9.7500	11.251+.001	.8125	7/8-9
A-20	18.2500	14.5000	16.251+.001	.8750	1-8
A-28	25.5000	20.8750	23.001+.001	1.000	1-1/4-7

### ➔ Camlock Spindle Type D1

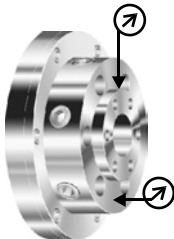
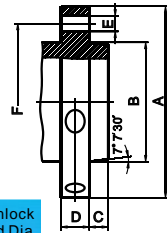

Spindle Nose	A	F	B	C max.	E	No. of Holes	Camlock Stud Dia
D1-3	3.622	2.7820	2.1250+.00025	.4375	.5937	3	9/16
D1-4	4.606	3.2500	2.5005+.0005	.4375	.6562		5/8
D1-5	5.748	4.1250	3.2505+.0005	.5000	.8750		3/4
D1-6	7.126	5.2500	4.1880+.0005	.5625	1.000	6	7/8
D1-8	8.858	6.7500	5.50075+.0005	.6250	1.125		1
D1-11	11.732	9.2520	7.75075+.0005	.6875	1.250		1-3/16
D1-15	15.866	13.0000	11.251+.001	.7500	1.375	1-3/8	



# Chuck Selection Guide

## ▶ German Standard DIN55027, Spindle Type C

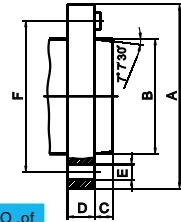
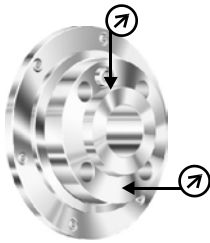

Spindle Nose	F	B	C max.	E	NO. of Holes
C-4	3.2500	2.5005	.4331	.83	3
C-5	4.1250	3.2505	.5118	.83	4
C-6	5.2500	4.1880	.5512	.91	4
C-8	6.7500	5.50075	.6299	1.14	4
C-11	9.2520	7.75075	.7087	1.42	6

## ▶ Long Taper Key Drive, Spindle Type L

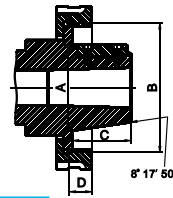
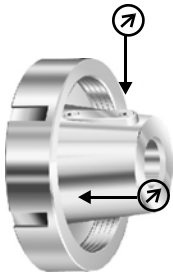

Spindle Nose	Thread B	C	A	Key
L00	3-3/4" - 6"	2	2.75	3/8 x3/8 x 1-1/2
L0	4-1/2" - 6"	2-3/8	3.250	3/8 x3/8 x 1-3/4
L1	6" - 6"	2-7/8	4.125	5/8 x5/8 x 2-3/8
L2	7-3/4"-5"	3-3/8	5.250	3/4 x3/4 x 2-7/8
L3	10-3/8"-4"	3-7/8	6.500	1 x1 x 3-1/4

## ▶ Threaded Spindle

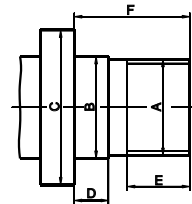
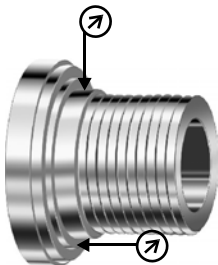

Spindle Nose A	B	F1	D	E
1"-10" UNS-2B	1.015	1.500	.4375	1.000
1-1/2"-8" UNS-2B	1.515	1.500	.4375	1.000
2-3/16"-10" UNS-2B	2.2025	1.750	.5625	1.125
2-1/4"-8" UNS-2B	2.260	1.750	.5625	1.125
2-3/16"-6" - UNS-2B	2.2025	1.750	.5625	1.125
2-3/4"-8" UNS-2B	2.760	2.0625	.6875	1.3125

# Chuck Selection Guide

## Permissible Spindle Runout

To obtain the specified clamping accuracy of a chuck mounted on a machine tool, it is necessary to:

1. Reduce play in the spindle bearings to allowable minimum.
2. Ensure the machine spindle nose does not exceed the values specified.
3. Meet the basic requirements for correct mounting of the chuck on the spindle nose.
4. Follow the chuck manual.

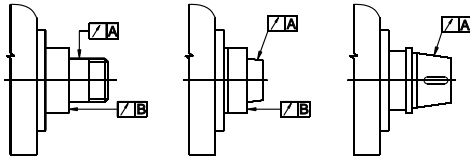

Chuck Dia.	Spindle Runout
PO Series Steel Body Chucks	
3" - 16"	.00012"max.
20" - 25"	.0002"max.
PS Series Semi-Steel Body	
3" - 6"	.00012"max.
8" - 32"	.0002"max.

## Self-Centering Scroll Chuck Accuracy

All allowable runouts which are specified concern measurements at three different jaw openings d(1, 2 & 3).

Chuck Dia. D	Universal and Precision Chuck Types: PA Series ,PO Series ,PS Series											
	d			L	n	p	s	w solid jaws	w 2 pc.jaws	Radial Runout		Axial Runout
	1	2	3							A	B	C
3-1/4"	0.39	-	0.55	1.57	1.57	2.36	1.38	2.48	-	0.0008	0.001	0.0006
4"	0.39	0.55	0.71	1.57	1.57	2.95	1.97	3.15	-	0.0008	0.001	0.0006
5"	0.71	0.98	1.18	2.36	1.97	3.94	2.44	3.94	4.72	0.0012	0.0014	0.0008
6-1/4"	0.71	1.18	1.57	2.36	1.97	5.31	3.46	3.94	5.9	0.0012	0.0014	0.0008
8"	1.18	1.57	2.08	3.15	3.15	6.38	3.78	6.3	7.28	0.0016	0.0018	0.001
10"	1.18	2.08	2.95	3.15	3.15	7.87	5.9	6.3	8.86	0.0016	0.0018	0.001
12-1/2"	2.08	2.95	3.94	4.72	4.92	9.92	8.27	9.84	11.81	0.002	0.0022	0.0012
15-3/4"	2.08	3.94	4.92	4.72	4.92	11.1	9.84	9.84	13.78	0.0024	0.0025	0.0012
20"	2.95	3.94	4.92	6.3	7.87	11.1	11.81	15.75	15.75	0.004	0.004	0.002
25"	2.95	4.92	6.3	6.3	7.87	12.79	15.75	15.75	15.75	0.004	0.004	0.002
31-1/2"	6.3	7.87	9.84	6.3	12.8	19.7	15.75	19.7	19.7	0.0059	0.0059	0.0024

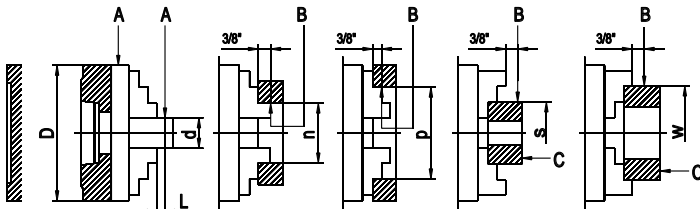

# Chuck Selection Guide

## Clamping Ranges for Self-Centering Scroll Chucks

**gator chucks™**  
BY FUERDA

Solid Jaws

Two-piece Reversible Jaws

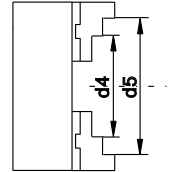
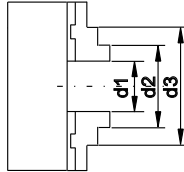
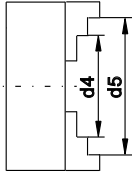
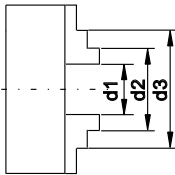

Chuck Diameter		d1		d2		d3 max.		d4 max.		d5 max.	
mm	inch	solid	reversible	solid	reversible	solid	reversible	solid	reversible	solid	reversible
60	2-1/3	.02-.95	-	.79-1.65	-	1.46-2.36	-	.79-1.65	-	1.50-2.36	-
80	3-1/4	.08-1.06	-	.87-1.81	-	1.77-2.72	-	.98-1.97	-	1.89-2.80	-
100	4	.12-1.30	-	.98-2.20	-	2.20-3.43	-	1.26-2.44	-	2.44-3.27	-
125	5	.12-1.97	.12-1.97	1.37-2.91	1.34-2.99	2.83-4.53	2.95-4.65	1.54-3.27	2.05-3.78	3.15-4.92	3.74-4.92
160	6-1/4	.12-2.52	.12-2.52	1.65-3.94	1.65-3.82	3.70-6.06	3.46-5.75	1.97-4.21	2.44-4.76	3.86-6.30	4.53-6.30
200	8	.16-3.54	.16-3.54	2.05-5.31	1.97-5.12	4.72-7.95	4.13-7.48	2.36-5.71	2.83-6.14	5.12-7.87	5.24-7.87
250	10	.20-4.65	.20-4.65	2.44-6.85	2.28-6.50	5.70-10.43	4.92-9.25	3.03-7.40	3.38-7.75	6.30-9.84	6.30-9.84
315	12-1/2	.39-5.16	.20-5.16	3.07-7.87	2.56-7.16	6.77-11.77	5.70-10.43	3.54-8.46	4.06-8.90	7.48-12.40	7.48-12.40
400	15-3/4	.39-7.09	.39-7.09	3.35-9.92	2.83-8.98	8.27-14.96	6.50-12.95	4.05-10.71	5.00-11.57	9.05-15.75	9.05-15.75
500	20	.79-9.25	.79-9.25	4.72-13.19	4.72-16.14	9.65-18.74	7.87-19.10	5.51-14.06	4.33-15.75	10.87-19.69	7.48-19.69
630	25	1.18-13.19	1.18-13.19	6.30-18.31	5.51-23.23	12.80-24.80	8.27-26.18	7.09-19.17	4.72-22.44	13.58-24.80	7.88-24.80
800	31-1/2	5.9-18.98	5.9-18.98	11.10-24.17	9.92-28.99	17.64-30.71	12.91-31.97	11.89-24.96	9.45-28.5	18.43-31.50	12.44-31.50

To Avoid a Chuck Gripping Problem,  
Select the proper Hard Top Jaws or Soft Top Jaws

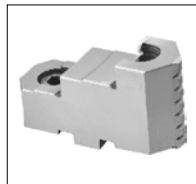
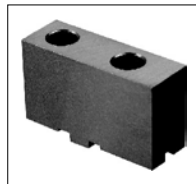

Jaw for Heavy Machining

Jaw for Special Applications

Jaw for Finishing

Quick Change Jaws

# Chuck Selection Guide

## Safe Operating Parameters

Conditions:  $l \geq z$  = maximum length of workpiece

$d$  = workpiece diameter

$h$  = height of the clamping jaw step

workpiece is clamped into the chuck jaws with out additional support.

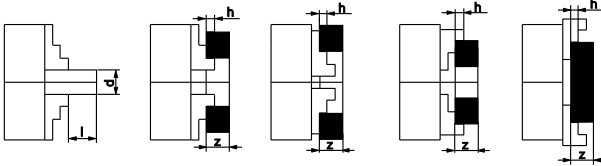

Chuck Diameter	3-1/4"	4"	5"	6-1/4"	8"	10"	12-1/2"	15-3/4"	20"	25"	31-1/2"
$l$	1.2 x $d$						1.5 x $d$			1 x $d$	
$z$	4 x $h$										

## Total Gripping Force of all Self-Centering Chucks (lbs.)

Chuck Diameter	3-1/4"	4"	5"	6-1/4"	8"	10"	12-1/2"	15-3/4"	20"	25"	31-1/2"
Steel & Semi-Steel Chucks	2,200	3,750	5,300	6,800	8,200	10,000	12,000	14,300	16,000	17,700	19,800
Torgue on the Wrench Nm	35	50	75	120	160	180	200	280	360	400	500

## Recommended Maximum Speeds for Self-Centering Chucks(RPM)

Chuck Diameter	3-1/4"	4"	5"	6-1/4"	8"	10"	12-1/2"	15-3/4"	20"	25"	31-1/2"
Universal Chucks(Semi-steel body)	4000	3500	3200	3000	2500	2000	1500	1000	700	500	300
Precision Chucks (Steel body)	6000	5200	4800	4500	4000	3500	2800	2000	1200	1000	450

## Value of Balancing for Precision Self-Centering Chucks Only.

Chuck Diameter	3-1/4"	4"	5"	6-1/4"	8"	10"	12-1/2"	15-3/4"	20"	25"
Balancing (ounce-inch)	0.15	0.22	0.32	0.44	0.62	0.87	1.25	1.94	4.16	8.88

## Lathe Chuck Safety Conditions

- ▶ Due to chuck rotating speeds and cutting forces during machining, care should be taken to insure the proper and safe use of your chuck.
- ▶ Cleaning should be done often for safety purposes as well as to provide a long work life for your chuck.
- ▶ Proper maintenance will insure your satisfaction.

### PRIOR TO OPERATING YOUR LATHE CHUCK, PLEASE:

- ▶ Read the chuck manual.
- ▶ Do not start the lathe until all is clear. A collision between the chuck and lathe will cause damage to both.
- ▶ Do not use the chuck on heavy work where the chuck jaws project appreciably from the chuck body. Refer to the tables on page 6 to select the correct size chuck for the application.
- ▶ Do not clamp long work pieces in the chuck without additional support, this can cause heavy damage to the lathe and work environment. Refer to the table on this page for safety parameters.
- ▶ Always remove the chuck wrench before starting the machine.
- ▶ Do not remove the safety spring from the chuck wrench.
- ▶ Never operate the chuck if any parts are damaged, missing or cracked.
- ▶ Do not tamper with the chuck. If an inaccuracy is found, check the spindle nose or adapter plate for true-running and make sure there is no dirt or foreign matter between the mounting faces.
- ▶ Never exceed maximum speed (RPM) of the chuck. The MAX RPM is stamped on the chuck face.
- ▶ Refer to the table on this page for recommended maximum speeds for self-centering chucks.
- ▶ Periodically inspect and service chucks for wear to avoid inadequate workholding conditions.
- ▶ Be sure top jaws are securely bolted to the master jaws.
- ▶ Never do any unauthorized chuck modifications.
- ▶ Always keep your chuck clean and lubricated.

# Chuck Selection Guide

## Quick Reference

### Part No..Page

1-101	12
1-102	12
1-103	12
1-104	12
1-105	15-19
1-106	15-19
1-107	15-19
1-115	18
1-119	36
1-125	18
1-201	20-28
1-202	20-28
1-203	20-28
1-204	20-28
1-205	23
1-207	30
1-211	22
1-221	23
1-241	22
1-301	31
1-302	31
1-311	33
1-312	32
1-317	35
1-321	33
1-322	32
1-901	37-38
1-903	37-38

### Part No.. Page

BA-SCREWS	18,24
CA-CAM STUDS	18,24
FL-ADAPTERS	27
FLA-ADAPTERS	13
FLD-ADAPTERS	28
FLE-ADAPTERS	38
FS-E	38
FS-P	14
HR-P	14,19
HR-PEO-	36
IJ-PS3	14,19,24
IJ-PS4	19,24
IJ-PS6	14
MB-BA	14
MB-PL	30
MJ-PEI-	35
MJ-PEO-	36
MJ-PI	34
MJ-PS2	24
MJ-PS3	14,19,24,36,38
MJ-PS4	19,24
MJ-PS6	14,38
MJ-PSL	30
MT-J1	24
MT-J2	24
OJ-PS3	14,19,24
OJ-PS4	19,24
OJ-PS6	14

### Part No.. Page

OS-PEI-	35
OS-PI	34
PH-E	38
PH-L	30
PH-P	23
PI-E	38
PI-PEO-	36
PI-PL	30
PI-PO	14,19
PI-PS	14,19,25
PS-P	14,19
RJ-PI	34
SC-PEO-	36
SC-PL	30
SC-PS	14,19,23,38
SJ-PI	34
SJ-PS3	14,19,24
SJ-PS4	19,24
SJ-PS6	14,19
STJ-PI	34
STJ-PS1	14,19,24,30,38
STJ-PS2	24
STJ-PS6	14,38
TB-PEI	35
TB-PI	34
TJ-PEI-	35
TJ-PEO-	36
TJ-PI	34
TJ-PS3	14,19,24,30,38
TJ-PS4	19,24
TJ-PS6	14,38
W-P	14,19,23,30,38
W-PEI	35
W-PL	30
W-PI	34



**gator chucks™**  
BY FUERDA



# Tech-Tru<sup>™</sup> PA Series Adjustable Chucks

PA Series Steel Body Adjustable Scroll Chucks can be used for all machining operations where universal chucks are used, along with applications where universal scroll chucks are unsuitable. Top accuracy, versatility and long life make PA Series chucks invaluable in the modern workshop and indispensable in the toolroom.



## PA Series Steel Body Adjustable Scroll Chucks, Medium Duty 3-Jaw & 6-Jaw, With Fine Adjustment, Forged Steel Body, 0.0004" T.I.R.

Note: 16" & 50" 3-Jaw Chucks are provided with the radial T-Slots located on the face of the chuck.

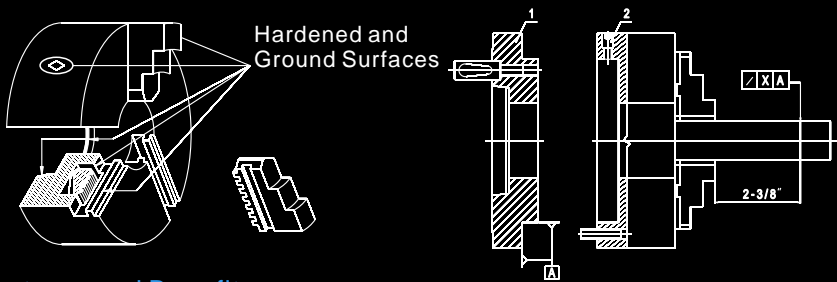

### Features and Benefits:

- With fine adjustment.
- Forged steel body.
- 3 pinion design.
- 4 micro adjustment screws provide 0.0004" T.I.R.
- 16", 20" and 25" diameter chucks with 3 jaws and 6 jaws use 8 micro adjustment screws achieving extremely high gripping concentricity.
- Two piece top & master jaws are American Standard tongue and groove.
- 4" diameter chuck has 2 sets of solid jaws.
- Chuck body is constructed of high quality forged steel, making it safe to run at high lathe speeds.
- Scrolls are forged and fully hardened with thread flanks ground on both sides, then precisely balanced for longer life and higher accuracy.
- Each scroll is precisely balanced.
- Jaw teeth and guides on both sides are fully hardened and ground. Hardened and ground bushings are pressed into the pinion seats. Pinions in 3 pinion models are hardened and ground.
- Each chuck is balanced within fine limits
- Steel mounting plates are interchangeable with PA Series chucks of the same size so that one chuck can be used on different spindles.
- The life of your Gator chuck can be extended significantly through proper maintenance.
- It must be cleaned on a regular basis as recommended.

## 3 & 6 Jaw Adjustable Scroll Chucks, 0.0004" T.I.R.

### Clamping Ranges

- Increased engagement of the scroll teeth and jaw teeth results in a more rigid setup with less stress on the chuck's guideways.

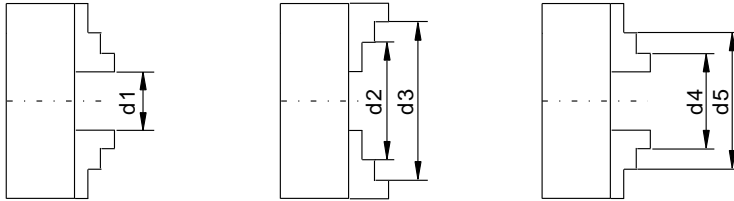

### 3-Jaw Chucks

- with Solid Jaws
- with Two-Piece Jaws

Chuck Diameter	4"	5"	6-1/4"	8"	10"	12-1/2"	15-3/4"	20"	25"	
Solid Jaws	d1	.118 - 1.30	.118 - 1.97	.118 - 2.52	.157 - 3.54	.197 - 4.65	.394 - 5.16	-	-	
	d2	1.26 - 2.44	1.54 - 3.27	1.97 - 4.21	2.36 - 5.71	3.03 - 7.40	3.54 - 8.46	-	-	
	d3	2.44 - 3.27	3.15 - 4.92	3.86 - 6.30	5.20 - 7.87	6.30 - 9.84	7.48 - 12.40	-	-	
	d4	.98 - 2.20	1.34 - 2.91	1.65 - 3.94	2.05 - 5.31	2.44 - 6.85	3.07 - 7.87	-	-	
	d5	2.20 - 3.43	2.83 - 4.53	3.70 - 6.06	4.72 - 7.95	5.71 - 10.08	6.77 - 11.77	-	-	
Two-Piece Jaws	d1	-	.118 - 1.97	.118 - 2.52	.157 - 3.54	.197 - 4.65	.394 - 5.16	.394 - 7.09	.787 - 9.25	1.18 - 13.19
	d2	-	2.05 - 3.78	2.44 - 4.76	2.83 - 6.14	3.39 - 7.76	4.06 - 8.90	5.00 - 11.57	4.33 - 15.75	4.72 - 22.44
	d3	-	3.74 - 4.92	4.53 - 6.30	5.24 - 7.87	6.30 - 9.84	7.48 - 12.40	9.06 - 15.75	7.48 - 19.69	7.87 - 24.80
	d4	-	1.34 - 2.99	1.65 - 3.81	1.97 - 5.12	2.28 - 6.50	2.56 - 7.17	2.84 - 8.98	4.72 - 16.14	5.51 - 23.23
	d5	-	2.95 - 4.65	3.46 - 5.75	4.13 - 7.48	4.92 - 9.25	5.71 - 10.43	6.50 - 12.95	7.87 - 19.09	8.27 - 26.18

### 6-Jaw Chucks

- with Solid Jaws
- with Two-Piece Jaws

Chuck Diameter	4"	5"	6-1/4"	8"	10"	12-1/2"	15-3/4"	20"	25"	
Solid Jaws	d1	.118 - 1.299	.236 - 1.69	.315 - 2.51	.315 - 3.54	.47 - 4.65	.47 - 5.16	-	-	
	d2	1.259 - 2.440	1.65 - 3.07	2.05 - 4.21	2.52 - 5.71	3.23 - 7.40	3.74 - 8.46	-	-	
	d3	2.440 - 3.661	3.27 - 4.72	4.02 - 6.30	5.20 - 7.87	6.50 - 9.84	7.56 - 12.40	-	-	
	d4	1.023 - 2.204	1.34 - 2.68	1.85 - 3.94	2.17 - 5.31	2.68 - 6.85	3.23 - 7.87	-	-	
	d5	2.244 - 3.425	2.91 - 4.33	3.86 - 6.06	4.76 - 7.95	5.91 - 10.08	7.01 - 11.77	-	-	
Two-Piece Jaws	d1	-	.236 - 1.69	.315 - 2.51	.315 - 3.54	.47 - 4.65	.47 - 5.16	.59 - 7.95	1.18 - 9.25	1.57 - 13.19
	d2	-	1.97 - 3.43	2.64 - 4.76	2.91 - 6.14	3.23 - 7.40	4.25 - 8.90	5.20 - 11.65	4.76 - 15.83	5.20 - 21.85
	d3	-	3.70 - 4.92	4.65 - 6.30	5.28 - 7.78	6.46 - 9.84	6.02 - 12.40	9.29 - 15.75	7.76 - 18.82	8.27 - 24.80
	d4	-	1.30 - 2.75	1.77 - 3.82	2.05 - 5.12	2.68 - 6.85	2.68 - 7.17	2.87 - 9.92	5.31 - 16.26	5.91 - 23.03
	d5	-	2.30 - 4.68	3.62 - 5.75	4.29 - 7.48	5.91 - 10.08	5.91 - 10.08	6.65 - 13.86	8.27 - 19.25	8.66 - 26.02

# Tech-Tru™ 3 & 6 Jaw PA Series Scroll Chucks, 0.0004" T.I.R.

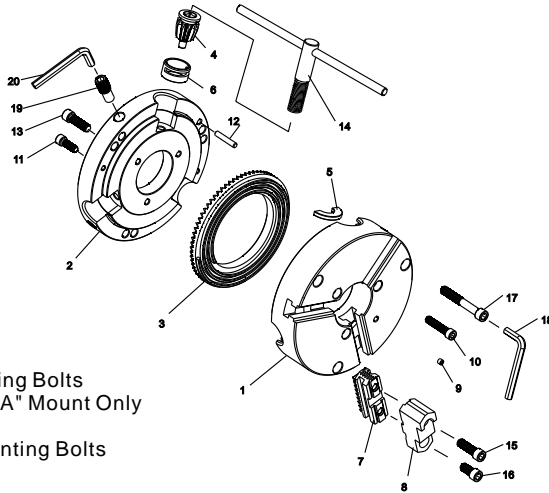

- 1. Chuck Body
- 2. Back Cover
- 3. Scroll Plate
- 4. Pinion
- 5. Pinion Half Ring
- 6. Pinion Sleeve
- 7. Hard Master Jaws
- 8. Hard Top Jaws
- 9. Grease Nipple
- 10. Chuck Mounting Bolts
- 11, 13. Back Cover Mounting Bolts
- 12. Spindle Locating Pin - "A" Mount Only
- 14. Chuck Wrench
- 15 & 16. Hard Top Jaw Mounting Bolts
- 17. Chuck Mounting Bolts
- 18 & 20. Hex Keys
- 19. Fine Adjustment Screw

Chuck Dia. D	F	E	A1	A	Hole d (max.)	H	2-Piece Jaws	Solid Jaws	C	Mounting Bolts M & T		Fine Adjustment Screws N	
							h			Thread	Qty.	Thread	Qty.
4"	3.2677	1.7717	-	-	0.787	2.677	-	0.63	0.51	M8 x 1.25	3	M10 x 1	4
5"	4.252	2.1654	-	-	1.378	2.362	1.575	0.787	0.59	M8 x 1.25		M12 x 1*	
6-1/4"	5.5118	3.3858	-	-	1.654	2.677	1.71	1.26	0.67	M10 x 1.5		M12 x 1	
8"	6.9291	4.3307	-	-	2.165	3.071	1.77	1.142	0.71	M10 x 1.5	6	M18 x 1	8
10"	8.8188	5.7086	-	-	2.992	3.504	2.05	1.339	0.79	M12 x 1.75			
12-1/2"	11.2598	7.0866	-	-	4.055	3.819	2.24	1.693	0.79	M16 x 2			
15-3/4"	6.75	-	11.748	11.782	5.354	4.803	2.638	-	0.87	5/8 x 11	6	M18 x 1	8
20"	9.252	-	16.022	16.032	7.48	5.669	3.11	-	1.18	3/4 x 10			
25"	13	-	16.022	16.032	9.921	5.905	3.425	-	1.18	3/4 x 10			

\* For 6 jaw chucks only

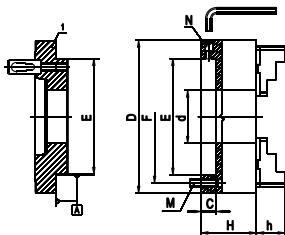

■ Chuck Diameters: 4" thru 12-1/2"

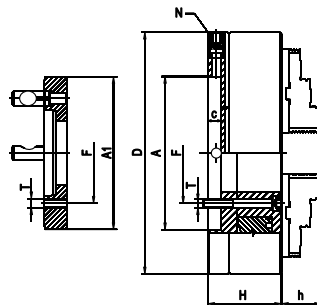

■ Chuck Diameters: 15-3/4", 20" & 25"

### 3 & 6 Jaw Adjustable Scroll Chucks, 0.0004" T.I.R.

with Fine Adjustment, Forged Steel Body, 3 Pinion Design  
Repeatability 0.006" .

#### ▶ 3-Jaw Scroll Chucks with Two-Piece Hard Reversible Jaws



■ Forged Steel Body

**Each chuck is provided with:**

- 1 set of hard master jaws
- 1 set of hard top reversible jaws
- 1 set of mounting bolts
- 1 set of fine adjustment screws
- 1 chuck wrench
- 2 hex keys
- eye bolts (10" and larger)

Chuck Dia.	Hole Dia.	RPM max.	Model	Part No.
5"	1.378	3800	PA3-5"A	1-101-0500
6-1/4"	1.654	3500	PA3-6"A	1-101-0600
8"	2.165	3100	PA3-8"A	1-101-0800
10"	2.992	2700	PA3-10"A	1-101-1000
12-1/2"	4.055	2200	PA3-12"A	1-101-1200
15-3/4"	5.354	1800	PA3-16"A	1-101-1600
20"	7.480	1200	PA3-20"A	1-101-2000
25"	9.921	1000	PA3-25"A	1-101-2500

■ 32",40",50"chucks are available on special order.

#### ▶ 3-Jaw Scroll Chucks with Two Sets of Hard Solid Jaws



■ Forged Steel Body

**Each chuck is provided with:**

- 1 set of hard solid ID jaws
- 1 set of hard solid OD jaws
- 1 set of mounting bolts
- 1 set of fine adjustment screws
- 1 chuck wrench
- 2 hex keys
- eye bolts (10" and larger)

Chuck Dia.	Hole Dia.	RPM max.	Model	Part No.
4"	.787	4200	PA3-4"	1-102-0400
5"	1.378	3800	PA3-5"	1-102-0500
6-1/4"	1.654	3500	PA3-6"	1-102-0600
8"	2.165	3100	PA3-8"	1-102-0800
10"	2.992	2700	PA3-10"	1-102-1000
12-1/2"	4.055	2200	PA3-12"	1-102-1200

#### ▶ 6-Jaw Scroll Chucks with Two-Piece Hard Reversible Jaws



■ Forged Steel Body

**Each chuck is provided with:**

- 1 set of hard master jaws
- 1 set of hard top reversible jaws
- 1 set of mounting bolts
- 1 set of fine adjustment screws
- 1 chuck wrench
- 2 hex keys
- eye bolts (10" and larger)

Chuck Dia.	Hole Dia.	RPM max.	Model	Part No.
5"	1.378	3000	PA6-5"A	1-103-0500
6-1/4"	1.654	2500	PA6-6"A	1-103-0600
8"	2.165	2200	PA6-8"A	1-103-0800
10"	2.992	1900	PA6-10"A	1-103-1000
12-1/2"	4.055	1500	PA6-12"A	1-103-1200
15-3/4"	5.354	1300	PA6-16"A	1-103-1600
20"	7.480	800	PA6-20"A	1-103-2000
25"	9.921	700	PA6-25"A	1-103-2500

■ 32",40",50"chucks are available on special order.

#### ▶ 6-Jaw Scroll Chucks with Two Sets of Hard Solid Jaws



■ Forged Steel Body

**Each chuck is provided with:**

- 1 set of hard solid ID jaws
- 1 set of hard solid OD jaws
- 1 set of mounting bolts
- 1 set of fine adjustment screws
- 1 chuck wrench
- 2 hex keys
- eye bolts (10" and larger)

Chuck Dia.	Hole Dia.	RPM max.	Model	Part No.
4"	.787	4000	PA6-4"	1-104-0400
5"	1.378	3000	PA6-5"	1-104-0500
6-1/4"	1.654	2500	PA6-6"	1-104-0600
8"	2.165	2200	PA6-8"	1-104-0800
10"	2.992	1900	PA6-10"	1-104-1000
12-1/2"	4.055	1500	PA6-12"	1-104-1200

# FLA Series Steel Adapter, Fully Machined \* for PA Series Chucks

\*Note: All these adapters do not require any additional machining



Type A



Type D



Chuck Dia.	Taper No	O.D.	TYPE A(A1,A2) Part No.	TYPE D Part No.
5"	3	4.92	--	FLA-125/D3
5"	4	4.92	--	FLA-125/D4
6-1/4"	3	6.30	--	FLA-160/D3
6-1/4"	4	6.30	--	FLA-160/D4
6-1/4"	5	6.30	FLA-160/A5	FLA-160/D5
8"	4	7.87	FLA-200/A4	FLA-200/D4
8"	5	7.87	FLA-200/A5	FLA-200/D5
8"	6	7.87	FLA-200/A6	FLA-200/D6
10"	5	9.87	FLA-250/A5	FLA-250/D5
10"	6	9.87	FLA-250/A6	FLA-250/D6
10"	8	9.87	FLA-250/A8	FLA-250/D8
12-1/2"	6	12.40	FLA-315/A6	FLA-315/D6
12-1/2"	8	12.40	FLA-315/A8	FLA-315/D8
12-1/2"	11	12.40	FLA-315/A11	FLA-315/D11
15-3/4"	6	15.83	FLA-400/A6	FLA-400/D6
15-3/4"	8	15.83	FLA-400/A8	FLA-400/D8
15-3/4"	11	15.83	FLA-400/A11	FLA-400/D11
20"	8	19.80	FLA-500/A8	FLA-500/D8
20"	11	19.80	FLA-500/A11	FLA-500/D11
20"	15	19.80	FLA-500/A15	FLA-500/D15
25"	8	24.80	FLA-630/A8	FLA-630/D8
25"	11	24.80	FLA-630/A11	FLA-630/D11
25"	15	24.80	FLA-630/A15	FLA-630/D15



Type L



Threaded



Chuck Dia.	O.D.	Taper Size	Thread T - UNS3	Part No.
6-1/4"	6.30	L00	3-3/4 - 6	FLA-160/L00
		L0	4-1/2 - 6	FLA-160/L0
8"	7.87	L00	3-3/4 - 6	FLA-200/L00
		L0	4-1/2 - 6	FLA-200/L0
		L1	6 - 6	FLA-200/L1
		L00	3-3/4 - 6	FLA-250/L00
10"	9.87	L0	4-1/2 - 6	FLA-250/L0
		L1	6 - 6	FLA-250/L1
		L0	4-1/2 - 6	FLA-315/L0
		L1	6 - 6	FLA-315/L1
12-1/2"	12.40	L2	7-3/4 - 5	FLA-315/L2
		L1	6 - 6	FLA-400/L1
		L2	7-3/4 - 5	FLA-400/L2
15-3/4"	15.83	L3	10-3/8 - 4	FLA-400/L3
		L2	7-3/4 - 5	FLA-500/L2
		L3	10-3/8 - 4	FLA-500/L3
20"	19.80	L2	7-3/4 - 5	FLA-500/L2

Chuck Dia.	O.D.	Thread d	Part No.
4"	3.94	1-10 UNS-2B	FLA-100/T1
		1-1/2 - 8 UN-2B	FLA-100/T2
		1-1/8 - 12W	FLA-125/T3
5"	4.92	1-1/2 - 8 UN-2B	FLA-125/T2
		2-3/16 - 10 Hardinge	FLA-125/T4
		2-1/4 - 8 UN-2B	FLA-125/T5
6-1/4"	6.30	1-1/2 - 8 UN-2B	FLA-160/T2
		2-3/16 - 10 Hardinge	FLA-160/T4
		2-1/4 - 8 UN-2B	FLA-160/T5
8"	7.87	1-1/2 - 8 UN-2B	FLA-200/T2
		2-1/4 - 8 UN-2B	FLA-200/T5
		2-3/8 - 6 UN-2B	FLA-200/T6
10"	9.87	2-3/8 - 6 UN-2B	FLA-250/T6
12-1/2"	12.40	2-3/8 - 6 UN-2B	FLA-315/T6



**SPARE PARTS FOR PA Series Adjustable  
3 & 6 Jaw Scroll Chucks With Forged Steel Body**



■ Sold in set.



■ Sold in set.

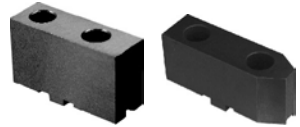

■ Sold by piece.

Part No ChuckDia.	Hard Top Jaws		Hard Master Jaws		Soft Top Jaws	
	3-Jaw	6-Jaw	3-Jaw	6-Jaw	3-Jaw	6-Jaw
5"	TJ-PS3-125	TJ-PS6-125	MJ-PS3-125	MJ-PS6-125	STJ-PS1-125	STJ-PS6-125
6-1/4"	TJ-PS3-160	TJ-PS6-160	MJ-PS3-160	MJ-PS6-160	STJ-PS1-160	STJ-PS6-160
8"	TJ-PS3-200	TJ-PS6-200	MJ-PS3-200	MJ-PS6-200	STJ-PS1-200	STJ-PS6-200
10"	TJ-PS3-250	TJ-PS6-250	MJ-PS3-250	MJ-PS6-250	STJ-PS1-250	STJ-PS6-250
12-1/2"	TJ-PS3-315	TJ-PS6-315	MJ-PS3-315	MJ-PS6-315	STJ-PS1-315	STJ-PS6-315
15-3/4"	TJ-PS3-400	TJ-PS6-400	MJ-PS3-400	MJ-PS6-400	STJ-PS1-400	STJ-PS6-400
20"	TJ-PS3-500	TJ-PS6-500	MJ-PS3-500	MJ-PS6-500	STJ-PS1-500	-
25"	TJ-PS3-630	TJ-PS6-630	MJ-PS3-630	MJ-PS6-630	STJ-PS1-630	-

■ Dimension please sea page 25.

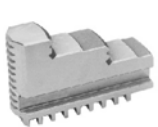

■ Sold in set.



■ Sold in set.



■ Sold in set.

Part No Chuck Dia.	I.D. Hard Solid Jaws		O.D. Hard Solid Jaws		Soft Solid Jaws	
	3-Jaw	6-Jaw	3-Jaw	6-Jaw	3-Jaw	6-Jaw
4"	OJ-PS3-100	OJ-PS6-100	IJ-PS3-100	IJ-PS6-100	SJ-PS3-100	-
5"	OJ-PS3-125	OJ-PS6-125	IJ-PS3-125	IJ-PS6-125	SJ-PS3-125	SJ-PS6-125
6-1/4"	OJ-PS3-160	OJ-PS6-160	IJ-PS3-160	IJ-PS6-160	SJ-PS3-160	SJ-PS6-160
8"	OJ-PS3-200	OJ-PS6-200	IJ-PS3-200	IJ-PS6-200	SJ-PS3-200	SJ-PS6-200
10"	OJ-PS3-250	OJ-PS6-250	IJ-PS3-250	IJ-PS6-250	SJ-PS3-250	-
12-1/2"	OJ-PS3-315	OJ-PS6-315	IJ-PS3-315	IJ-PS6-315	SJ-PS3-315	-

■ Dimension please sea page 26.



Sold by Piece

Chuck Dia	Scroll Plate	Pinion	Wrench*	Pinion Sleeve	Half Ring	Fine Adjustment Screws	Mounting bolts
4"	SC-PS-100	PI-PS-100	W-P-125	-	-	FS-P-100	MB-BA-100
5"	SC-PS-125	PI-PO-125	W-P-125	PS-P-125	HR-P-125	FS-P-125	MB-BA-125
6-1/4"	SC-PS-160	PI-PO-160	W-P-200	PS-P-160	HR-P-160	FS-P-160	MB-BA-160
8"	SC-PS-200	PI-PO-200	W-P-200	PS-P-200	HR-P-200	FS-P-200	MB-BA-200
10"	SC-PS-250	PI-PO-250	W-P-315	PS-P-250	HR-P-250	FS-P-250	MB-BA-250
12-3/2"	SC-PS-315	PI-PO-315	W-P-315	PS-P-315	HR-P-315	FS-P-315	MB-BA-315
15-3/4"	SC-PS-400	PI-PO-400	W-P-400	PS-P-400	HR-P-400	FS-P-400	MB-BA-400
20"	SC-PS-500	PI-PO-500	W-P-630	PS-P-500	HR-P-500	FS-P-500	MB-BA-500
25"	SC-PS-630	PI-PO-630	W-P-630	PS-P-630	HR-P-630	FS-P-630	MB-BA-630

\*W-SP- Extended Wrenches available from stock.

# PO Series Precision Steel Body, Medium Duty 3-Jaw & 4-Jaw Self-Centering Scroll Chucks

## ▶ Forged Steel Body ▶ High Speed

- Extremely accurate, and guaranteed to maintain this exceptional accuracy for an extended period of time.
- Chucks have a modern and compact design, are used where high precision machining is demanded, and are capable of meeting the highest demands of our customers.

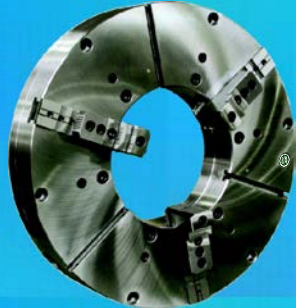

Note: 16" & 50" 3-Jaw Chucks are provided with the radial T-Slots located on the face of the chuck.

### ■ Chuck Body

Drop forged of high grade steel, then put through precise machining operations. All bearing surfaces are carefully hardened and precisely ground.

### ■ Scroll Plate

Drop forged of fine quality alloy steel, and carefully case hardened. Thread flanks are ground on both sides. Each scroll is balanced.

### ■ Jaws

Made of fine alloy steel. Teeth and Guides hardened and fully Ground on both sides.

### ■ Pinions

Hardened and ground fine alloy steel.

### ■ Bushings

Made of fine alloy steel. Hardened and ground, then pressed into the pinion seats.

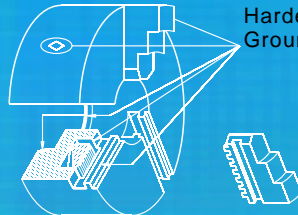

Hardened and  
Ground Surfaces

### ■ Precision grinding of scroll plate and jaw teeth allows you to:

Eliminate the possibility of deformation as a result of heat treatment.  
Reach uniform radial gripping force on all teeth of jaws.  
Increase guarantee period for high centering accuracy.

# PO Series Precision Steel Body, Medium Duty 3-Jaw & 4-Jaw Self-Centering Scroll Chucks



- 1. Chuck Body
- 2. Back Cover
- 3. Scroll Plate
- 4. Pinion
- 5. Pinion Half Ring
- 6. Pinion Sleeve
- 7. Hard Master Jaws
- 8. Hard Top Jaws
- 9. Grease Nipple
- 10. Back Cover Mounting Bolts
- 11. Chuck Mounting Bolts
- 12. Back Cover Mounting Pin
- 13. Back Cover Mounting Bolts
- 14. Chuck Wrench
- 15.&16. Jaw mounting bolts

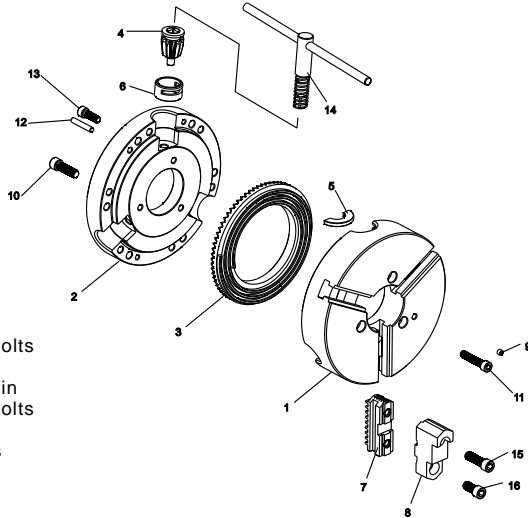

## Clamping Ranges for 3 & 4 Jaw Chucks with Two-Piece Reversible Jaws & Solid Jaws

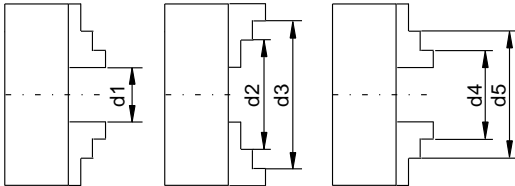

Chuck Diameter	3-1/4"	4"	5"	6-1/4"	8"	10"	12-1/2"	15-3/4"	20"	25"	32"
Solid Jaws	d1	.08-1.06	.118-1.30	.118-1.97	.118-2.52	.157-3.54	.197-4.65	.394-5.16	-	-	-
	d2	.98-1.97	1.26-2.44	1.54-3.27	1.97-4.21	2.36-5.71	3.03-7.40	3.54-8.46	-	-	-
	d3	1.10-2.80	2.44-3.27	3.15-4.92	3.86-6.30	5.12-7.87	6.30-9.84	7.48-12.40	-	-	-
	d4	.87-1.81	.98-2.20	1.34-2.91	1.65-3.94	2.05-5.31	2.44-6.85	3.07-7.87	-	-	-
	d5	1.77-2.72	2.20-3.43	2.83-4.53	3.70-6.06	4.72-7.95	5.71-10.08	6.77-11.77	-	-	-
Two-Piece Jaws	d1	-	-	.118-1.97	.118-2.52	.157-3.54	.197-4.65	.394-5.16	.787-9.25	1.18-13.19	5.91-18.98
	d2	-	-	2.05-3.78	2.44-4.76	2.83-6.14	3.39-7.76	4.06-8.90	5.00-11.57	4.33-15.75	4.72-22.44
	d3	-	-	3.74-4.92	4.53-6.30	5.24-7.87	6.30-9.84	7.48-12.40	9.06-15.75	7.48-19.69	7.87-24.80
	d4	-	-	1.34-2.99	1.65-3.81	1.97-5.12	2.28-6.50	2.56-7.17	2.84-8.98	4.72-16.14	5.51-23.23
	d5	-	-	2.95-4.65	3.46-5.75	4.13-7.48	4.92-9.25	5.71-10.43	6.50-12.95	7.87-19.09	8.27-26.18

## PO Series Precision Steel Body Chucks

### ▶ 3 Jaw & 4 Jaw Self-centering Chucks, forged steel body, Plain Back, Medium Duty, Adapters required.

Principal Dimensions - Back Mounting

Chuck Dia. D	F	E	d	C	H	h	Adapter Mounting Bolts		
							Thread M	L	No. of Bolts
3-1/4"	2.6387	2.2047	0.6299	.1181	1.732	-	M6 x 1	0.98	3
4"	3.2677	2.7559	0.7874	.1181	1.969	-	M8 x 1.25		
5"	4.2520	3.7402	1.3976	.1575	2.422	1.575	M10 x 1.5		
6-1/4"	5.5118	4.9213	1.6535	.1575	2.756	1.693	M12 x 1.75	1.18	6
8"	6.9291	6.2992	2.1654	.1575	3.150	1.772			
10"	8.8189	7.8740	2.9921	.1969	3.543	2.087	M16 x 2	1.57	
12-1/2"	11.2598	10.2362	4.0551	.1969	3.937	2.244			
15-3/4"	14.2519	12.9921	5.3543	.1969	4.331	2.693	1"-8	5.61	
20"	18.0314	16.5354	7.4803	.1969	4.685	3.150			
25"	23.0709	21.4567	9.9212	.2756	5.079	3.425			
32"	14.5000	17.7170	10.5118	.7874	5.906	3.425			

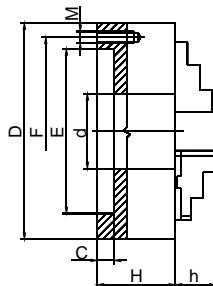

### ■ 3-Jaw Scroll Chuck with Two-Piece Hard Reversible Jaws



Each chuck is provided with:

- 1 set of hard master jaws
- 1 set of hard top reversible jaws
- 1 chuck wrench
- 1 set of mounting bolts
- 2 hex keys
- Forged steel body
- 3 pinion design
- eye bolts for chuck size 10" diameter and larger

Chuck Dia.	Hole Dia.	RPM max.	Model	Part No.
5"	1.3976	4800	PO3-5"A	1-105-0500
6-1/4"	1.6535	4500	PO3-6"A	1-105-0600
8"	2.1654	4000	PO3-8"A	1-105-0800
10"	2.9921	3500	PO3-10"A	1-105-1000
12-1/2"	4.0551	2800	PO3-12"A	1-105-1200
15-3/4"	5.3543	2000	PO3-16"A	1-105-1600
20"	7.480	1200	PO3-20"A	1-105-2000
25"	9.921	1000	PO3-25"A	1-105-2500
32"	10.5118	450	PO3-32"A	1-105-3200

■ 40",50"chucks are available on special order.

### ■ 3-Jaw Scroll Chucks with Two Sets of Hard Solid Jaws



Each chuck is provided with:

- 1 set of hard solid ID jaws
- 1 set of hard solid OD jaws
- 1 chuck wrench
- 1 set of mounting bolts
- 2 hex keys
- Forged steel body
- 3 pinion design
- eye bolts for chuck sizes 10" diameter and larger

Chuck Dia.	Hole Dia.	RPM max.	Model	Part No.
3-1/4"	.6299	6000	PO3-3"	1-106-0300
4"	.7874	5200	PO3-4"	1-106-0400
5"	1.3786	4800	PO3-5"	1-106-0500
6-1/4"	1.6535	4500	PO3-6"	1-106-0600
8"	2.1654	4000	PO3-8"	1-106-0800
10"	2.9921	3500	PO3-10"	1-106-1000
12-1/2"	4.0551	2800	PO3-12"	1-106-1200

### ■ 4-Jaw Scroll Chuck with Two-Piece Hard Reversible Jaws



Each chuck is provided with:

- 1 set of hard master jaws
- 1 set of hard top reversible jaws
- 1 chuck wrench
- 1 set of mounting bolts
- 2 hex keys
- Forged steel body
- 2 pinion design
- eye bolts for chuck size 10" diameter and larger
- 4-Jaw Scroll Chuck with Two set of Hard Solid Jaws available.

Chuck Dia.	Hole Dia.	RPM max.	Model	Part No.
8"	2.1654	4000	PO4-8"A	1-107-0800
10"	2.9921	3500	PO4-10"A	1-107-1000
12-1/2"	4.0551	2800	PO4-12"A	1-107-1200
15-3/4"	5.3543	2000	PO4-16"A	1-107-1600

## ▶ 3-Jaw ,Type A1/A2, Direct Mount Self-Centering Scroll Chucks With Two Piece Hard Reversible Jaws,Medium Duty

- Forged steel body.      ■ High speed.
- Type A1 spindle has a 2 bolt hole pattern, inside (size B1), and outside the taper (size B). Either an A1 or A2 chuck will fit on it.
- Type A2 spindle has 1 bolt pattern, outside the taper (size B).



Type A

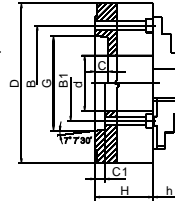

Chuck Dia.	Taper Size	Hole Dia.(d)	RPM max.	wt. lbs.	Model	Chuck Part No.	B (A2)	B1 (A1)	G	C/C1*	H	h	Screws M			
													Thread	L	Qty. Part NO.	
6-1/4"	A1-5	1.6535	4500	22	PO3-6"/AA1-5	1-115-0605	-	2.4374	3.2505	.563	2.6772	1.693	7/16-14	2-3/8	3	BA-06-05
	A1-6	2.1653	4000	42	PO3-8"/AA1-5	1-115-0805	-	-	-	-	-	-	2-3/4	3		BA-08-05
8"	A1-6	2.1653	3500	71	PO3-8"/AA1-6	1-115-0806	-	3.2500	4.1880	.625	3.0709	1.772	1/2-13	3-1/8	6	BA-08-06
	A1-8	2.9921	2800	121	PO3-10"/AA1-6	1-115-1006	-	4.3750	5.5007	.688	3.5039	2.087	5/8-11	2-3/4		BA-10-06
10"	A1-8	2.9921	2800	121	PO3-10"/AA1-8	1-115-1008	-	4.3750	5.5007	.688	3.5039	2.087	5/8-11	2-3/4	6	BA-10-08
	A2-6	4.0551	2800	121	PO3-12"/AA2-6	1-115-1206	5.2520	-	4.1880	.630	3.7874	2.244	1/2-13	4		BA-12-06
12-1/2"	A1-8	3.1496	2800	121	PO3-12"/AA1-8	1-115-1208	-	4.3750	5.5007	.688	3.7874	2.244	5/8-11	3-1/8	6	BA-12-08
	A2-8	5.3543	2000	203	PO3-16"/AA2-8	1-115-1608	6.7480	-	6.5000	.709	4.2520	2.639	3/4-10	4-5/16		BA-16-08
15-3/4"	A1-11	5.1181	2000	203	PO3-16"/AA1-11	1-115-1611	-	6.5000	7.7507	.750	4.2520	2.639	3/4-10	4-1/2	6	BA-16-11
	A2-8	5.3543	1200	353	PO3-20"/AA2-8	1-115-2008	6.7480	-	5.5007	.709	4.6850	3.091	5/8-11	4-3/4		BA-20-08
20"	A2-11	7.4803	1000	628	PO3-20"/AA2-11	1-115-2011	9.2520	-	7.7507	.787	5.0787	3.425	3/4-10	5-5/16	6	BA-20-11
	A2-15	9.9213	1000	628	PO3-25"/AA2-15	1-115-2515	13.000	-	11.251	.813	5.0787	3.425	7/8-9	5-1/8		BA-25-11

\*C-C1, depth of counterbore.

## ▶ 3-Jaw ,Type D1, Direct Mount Self-Centering Scroll Chucks With Two Piece Hard Reversible Jaws,Medium Duty

- Forged steel body.      ■ High speed.



Type D1

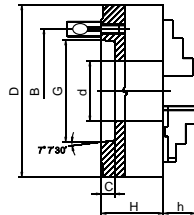

Chuck Dia.	Taper Size	Hole Dia.(d)	RPM max.	wt. lbs.	Model	Chuck Part No.	B	G	C	H	h	Camlock Studs			
												OD	Thread	Qty.	Part No.
6-1/4"	D1-3	1.6535	4500	20	PO3-6"/AD1-3	1-125-0603	2.7795	2.1250	.5118	2.6772	1.693	9/16	M10 x 1	3	CA-D-03
	D1-4				PO3-6"/AD1-4	1-125-0604	3.2520	2.5005				5/8			CA-D-04
8"	D1-5	2.1653	4000	42	PO3-6"/AD1-5	1-125-0605	4.1260	3.7505	.5629	3.0719	1.772	3/4	M12 x 1	6	CA-D-05
	D1-6				PO3-8"/AD1-5	1-125-0805	4.1260	3.2505				7/8			CA-D-06
10"	D1-6	2.9921	3500	71	PO3-8"/AD1-6	1-125-0806	5.2520	4.1880	.6299	3.5039	2.087	1	M16 x 1.5	6	CA-D-06
	D1-8				PO3-10"/AD1-6	1-125-1006	5.2520	4.1880				1			CA-D-08
12-1/2"	D1-6	4.0551	2800	112	PO3-10"/AD1-8	1-125-1008	6.7480	5.5007	.7087	3.7874	2.244	1	M20 x 1.5	6	CA-D-08
	D1-8				PO3-12"/AD1-6	1-125-1206	5.2520	4.1880				7/8			CA-D-06
15-3/4"	D1-8	5.3543	2000	223	PO3-12"/AD1-8	1-125-1208	6.7480	5.5007	.7087	4.3976	2.639	1	M22 x 1.5	6	CA-D-08
	D1-11				PO3-12"/AD1-11	1-125-1211	9.2520	7.7507				1-3/16			CA-D-11
20"	D1-8	7.5984	1200	331	PO3-16"/AD1-8	1-125-1608	6.7480	5.5007	.7087	4.2570	2.639	1	M20 x 1.5	6	CA-D-08
	D1-11				PO3-16"/AD1-11	1-125-1611	9.2520	7.7507				1-3/16			CA-D-11
25"	D1-11	7.4803	1000	604	PO3-20"/AD1-11	1-125-2011	9.2520	7.7507	.7874	4.6850	3.150	1	M22 x 1.5	6	CA-D-11
	D1-11				PO3-25"/AD1-11	1-125-2511	9.2520	7.7507				1-3/16			CA-D-11



# PO Series Precision Steel Body Chucks ► SPARE PARTS ◀



■ Sold in set.



■ Sold in set.

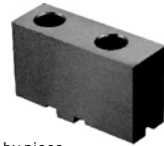

■ Sold by piece.

Part No.	Hard Top Jaws		Hard Master Jaws		Soft Top Jaws	
	3-Jaw	4-Jaw	3-Jaw	4-Jaw	3-Jaw	4-Jaw
Chuck Dia.						
5"	TJ-PS3-125	-	MJ-PS3-125	-	STJ-PS1-125	-
6-1/4"	TJ-PS3-160	-	MJ-PS3-160	-	STJ-PS1-160	-
8"	TJ-PS3-200	TJ-PS4-200	MJ-PS3-200	MJ-PS4-200	STJ-PS1-200	STJ-PS1-200
10"	TJ-PS3-250	TJ-PS4-250	MJ-PS3-250	MJ-PS4-250	STJ-PS1-250	STJ-PS1-250
12-1/2"	TJ-PS3-315	TJ-PS4-315	MJ-PS3-315	MJ-PS4-315	STJ-PS1-315	STJ-PS1-315
15-3/4"	TJ-PS3-400	TJ-PS4-400	MJ-PS3-400	MJ-PS4-400	STJ-PS1-400	STJ-PS1-400
20"	TJ-PS3-500	-	MJ-PS3-500	-	STJ-PS1-500	-
25"	TJ-PS3-630	-	MJ-PS3-630	-	STJ-PS1-630	-
32"	TJ-PS3-800	-	MJ-PS3-800	-	STJ-PS1-800	-

■ Dimension please see page 25.

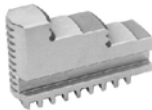

■ Sold in set.



■ Sold in set.



■ Sold in set.

Part No.	I.D. Hard Solid Jaws		O.D. Hard Solid Jaws		Soft Solid Jaws	
	3-Jaw	4-Jaw	3-Jaw	4-Jaw	3-Jaw	4-Jaw
Chuck Dia.						
3-1/4"	OJ-PS3-080	-	IJ-PS3-080	-	SJ-PS3-080	-
4"	OJ-PS3-100	OJ-PS4-125	IJ-PS3-100	IJ-PS4-100	SJ-PS3-100	-
5"	OJ-PS3-125	OJ-PS4-125	IJ-PS3-125	IJ-PS4-125	SJ-PS3-125	SJ-PS4-125
6-1/4"	OJ-PS3-160	OJ-PS4-160	IJ-PS3-160	IJ-PS4-160	SJ-PS3-160	SJ-PS4-160
8"	OJ-PS3-200	OJ-PS4-200	IJ-PS3-200	IJ-PS4-200	SJ-PS3-200	SJ-PS4-200
10"	OJ-PS3-250	OJ-PS4-250	IJ-PS3-250	IJ-PS4-250	SJ-PS3-250	SJ-PS4-250
12-1/2"	OJ-PS3-315	OJ-PS4-315	IJ-PS3-315	IJ-PS4-315	SJ-PS3-315	SJ-PS4-315
15-3/4"	OJ-PS3-400	-	IJ-PS3-400	-	SJ-PS3-400	SJ-PS4-400
20"	OJ-PS3-500	-	IJ-PS3-500	-	-	-
25"	OJ-PS3-630	-	IJ-PS3-630	-	-	-
32"	OJ-PS3-800	-	IJ-PS3-800	-	-	-

■ Dimension please see page 26.



Part No.

Chuck Dia.	Scroll Plate	Pinion	Wrench *	Pinion Sleeve	Half Ring
3-1/4"	SC-PS-080	PI-PS-080	W-P-080	-	-
4"	SC-PS-100	PI-PS-100	W-P-125	-	-
5"	SC-PS-125	PI-PO-125	W-P-125	PS-P-125	HR-P-125
6-1/4"	SC-PS-160	PI-PO-160	W-P-200	PS-P-160	HR-P-160
8"	SC-PS-200	PI-PO-200	W-P-200	PS-P-200	HR-P-200
10"	SC-PS-250	PI-PO-250	W-P-315	PS-P-250	HR-P-250
12-3/2"	SC-PS-315	PI-PO-315	W-P-315	PS-P-315	HR-P-315
15-3/4"	SC-PS-400	PI-PO-400	W-P-400	PS-P-400	HR-P-400
20"	SC-PS-500	PI-PO-500	W-P-630	PS-P-500	HR-P-500
25"	SC-PS-630	PI-PO-630	W-P-630	PS-P-630	HR-P-630
32"	SC-PS-800	PI-PO-800	W-P-800	PS-P-800	HR-P-800

■ Sold by piece.

\*W-SP- Extended Wrenches available from stock.

# PS Series Universal Chucks



**3 Jaw,4 Jaw,2 Jaw Self-Centering  
Semi-Steel body  
Medium Duty**

These chucks can be used on all types of lathes, and on different kinds of milling, drilling and CNC attachments.

Chucks come with either American Standard two-piece tongue and groove jaws, or two sets of hard solid OD & ID jaws.

Plain Back & Direct Mount.  
Semi-steel body.

Chuck body is made of high quality cast iron. All guide ways and bearing surfaces are precisely machined.

Scroll plate is drop forged of fine alloy steel, and carefully case hardened. Thread flanks are ground on both sides.

The jaw's teeth and guide ways are hardened and fully ground on both sides.

Pinions are hardened and ground.

## ■ Chucks with Two-Piece Reversible Jaws

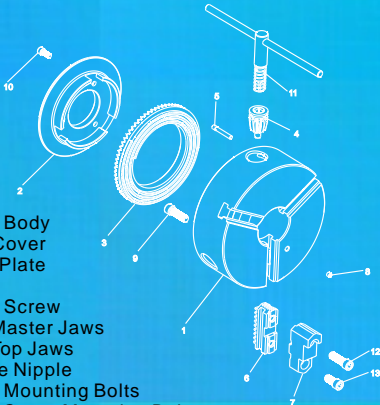

1. Chuck Body
2. Back Cover
3. Scroll Plate
4. Pinion
5. Pinion Screw
6. Hard Master Jaws
7. Hard Top Jaws
8. Grease Nipple
9. Chuck Mounting Bolts
10. Back Cover Mounting Bolts
11. Chuck Wrench
- 12 & 13. Jaw Mounting Bolts

## ■ Chucks with Two Sets of OD & ID Hard Solid Jaws

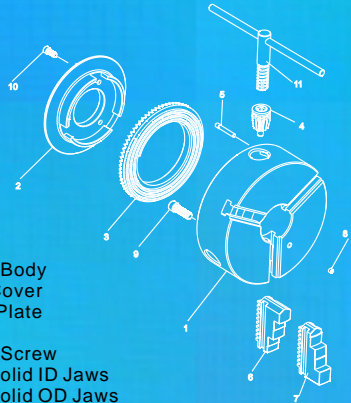

1. Chuck Body
2. Back Cover
3. Scroll Plate
4. Pinion
5. Pinion Screw
6. Hard Solid ID Jaws
7. Hard Solid OD Jaws
8. Grease Nipple
9. Chuck Mounting Bolts
10. Back Cover Mounting Bolts
11. Chuck Wrench

**gator chucks™**  
BY FUERDA

## PS Series Universal Chucks

### ▶ 3 Jaw & 4 Jaw Self-centering Chucks, Semi-steel Body, Medium Duty Plain Back, Adapters required,

#### Principal Dimensions - Back Mounting

Chuck Dia. D	F	E	d	C	H	h	h1	Adapter Mounting Bolts		
								Thread M	L	No. of Bolts
3-1/4"	2.6378	2.2047	0.6299	.1181	1.732	-	0.512	M6X1		3
4"	3.2677	2.7559	0.7874	.1181	1.969	-	0.669	M8 x 1.25	0.98	
5"	4.2520	3.7402	1.2598	.1575	2.205	1.575	0.787			
6-1/4"	5.5118	4.9213	1.6535	.1575	2.539	1.693	1.26	M10 x 1.5	1.18	6
8"	6.9291	6.2992	2.1654	.1575	2.953	1.772	1.142			
10"	8.8189	7.8740	2.9921	.1969	3.347	2.087	1.339	M12 x 1.75	1.57	
12-1/2"	11.2598	10.2362	4.0551	.1969	3.701	2.244	1.693			
15-3/4"	14.2519	12.9921	5.3543	.1969	4.134	2.693	2.165	M16 x 2	1.97	
20"	18.0314	16.5354	7.7840	.2362	4.5276	3.504	2.205			
25"	23.0709	21.4567	10.2362	.2756	5.1575	3.465	2.756	1"-8	5.96	
32"	14.5000	17.7170	12.6000	.7874	6.2598	3.465	2.756			

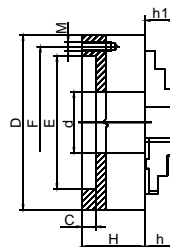

■ 40" Chucks available on special order.

### ▶ 3-Jaw Scroll Chucks with Two-Piece Hard Reversible Jaws

#### Each chuck is provided with:

- 1 set of hard master jaws
- 1 set of hard top reversible jaws
- 1 set of mounting bolts
- 1 chuck wrench
- 2 hex keys
- eye bolts with 10"-32" chucks
- 3 pinion design



Chuck Dia.	Hole Dia.	Max.Hole Enlargements	RPM max.	Model	Part No.
5"	1.2598	1.3465	3200	PS3-5"A	1-201-0500
6-1/4"	1.6535	1.9252	3000	PS3-6"A	1-201-0600
8"	2.1654	2.8189	2500	PS3-8"A	1-201-0800
10"	2.9921	3.5827	2000	PS3-10"A	1-201-1000
12-1/2"	4.0551	4.3300	1500	PS3-12"A	1-201-1200
15-3/4"	5.3543	5.7480	1000	PS3-16"A	1-201-1600
20"	7.4803	8.3465	700	PS3-20"A	1-201-2000
25"	9.9210	12.047	500	PS3-25"A	1-201-2500
32"	12.600	-	300	PS3-32"A	1-201-3200

### ▶ 3-Jaw Scroll Chucks with Two Sets of Hard Solid Jaws

#### Each chuck is provided with:

- 1 set of hard solid ID jaws
- 1 set of hard solid OD jaws
- 1 set of mounting bolts
- 1 chuck wrench
- 2 hex keys
- eye bolts with 10"-32" chucks
- 3 pinion design



Chuck Dia.	Hole Dia.	Max.Hole Enlargements	RPM max.	Model	Part No.
3-1/4"	.6299	0.7087	4000	PS3-3"	1-202-0300
4"	.7874	0.9055	3500	PS3-4"	1-202-0400
5"	1.2598	1.3465	3200	PS3-5"	1-202-0500
6-1/4"	1.6535	1.9252	3000	PS3-6"	1-202-0600
8"	2.1654	2.8189	2500	PS3-8"	1-202-0800
10"	2.9921	3.5827	2000	PS3-10"	1-202-1000
12-1/2"	4.0551	4.3300	1500	PS3-12"	1-202-1200
15-3/4"	5.3543	5.7480	1000	PS3-16"	1-202-1600
20"	7.4803	8.3465	700	PS3-20"	1-202-2000

### ▶ 4-Jaw Scroll Chucks with Two-Piece Hard Reversible Jaws

#### Each chuck is provided with:

- 1 set of hard master jaws
- 1 set of hard top reversible jaws
- 1 set of mounting bolts
- 1 chuck wrench
- 2 hex keys
- eye bolts with 10"-25" chucks
- 2 pinion design



Chuck Dia.	Hole Dia.	Max.Hole Enlargements	RPM max.	Model	Part No.
5"	1.2598	1.3465	3200	PS4-5"A	1-203-0500
6-1/4"	1.6535	1.9252	3000	PS4-6"A	1-203-0600
8"	2.1654	2.8189	2500	PS4-8"A	1-203-0800
10"	2.9921	3.5827	2000	PS4-10"A	1-203-1000
12-1/2"	4.0551	4.3300	1500	PS4-12"A	1-203-1200
15-3/4"	5.3543	5.7480	1000	PS4-16"A	1-203-1600
20"	7.4803	8.3465	700	PS4-20"A	1-203-2000
25"	9.9210	12.047	500	PS4-25"A	1-203-2500

### ▶ 4-Jaw Scroll Chucks with Two Sets of Hard Solid Jaws

#### Each chuck is provided with:

- 1 set of hard solid ID jaws
- 1 set of hard solid OD jaws
- 1 set of mounting bolts
- 1 chuck wrench
- 2 hex keys
- eye bolts with 10"-15-3/4" chucks
- 2 pinion design



Chuck Dia.	Hole Dia.	Max.Hole Enlargements	RPM max.	Model	Part No.
4"	.7874	0.9055	3500	PS4-4"	1-204-0400
5"	1.2598	1.3465	3200	PS4-5"	1-204-0500
6-1/4"	1.6535	1.9252	3000	PS4-6"	1-204-0600
8"	2.1654	2.8189	2500	PS4-8"	1-204-0800
10"	2.9921	3.5827	2000	PS4-10"	1-204-1000
12-1/2"	4.0551	4.3300	1500	PS4-12"	1-204-1200
15-3/4"	5.3543	5.7480	1000	PS4-16"	1-204-1600

**▶ 3-Jaw ,Type A1/A2, Direct Mount Self-Centering Scroll Chucks With Two Piece Hard Reversible Jaws,Medium Duty**

- Semi-steel body.
- Type A1 spindle has a 2 bolt hole pattern, inside (size B1) and outside the taper (size B). Either an A1 or A2 chuck will fit on it.
- Type A2 spindle has 1 bolt pattern, outside the taper (size B),only an A2 chuck will fit on it.



Type A

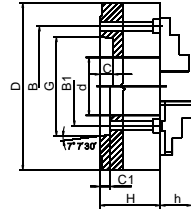

Chuck Dia.	Taper Size	Hole Dia.(d)	RPM max.	wt. lbs.	Model	Chuck Part No .	B (A2)	B1 (A1)	G	C/C1	H	h	Chuck Mounting Bolts			
													Thread	L	Qty.	Part No .
6-1/4"	A1-5	1.6535	3000	22	PS3-6"/A1-5	1-211-0605	-		3.2505	.563	3.2087	1.693	7/16-14	2-3/4	3	BA-06-05
8"	A1-5	1.6535	2500	42	PS3-8"/A1-5	1-211-0805	-	2.4374	3.2505	.563	3.5827	1.772	7/16-14	3-1/8	3	BA-08-05
	A1-6	2.1653			PS3-8"/A1-6	1-211-0806	-	3.2500	4.1880	.625			1/2-13			BA-08-06
10"	A2-5	2.9921	2000	71	PS3-10"/A2-5	1-211-1005	4.1260	-	3.2505	.563	4.0748	2.087	7/16-14	4-1/8	6	BA-10-05
	A1-6	2.1635			PS3-10"/A1-6	1-211-1006	-	3.2500	4.1880	.625			1/2-13			BA-10-06
	A1-8	2.9921			PS3-10"/A1-8	1-211-1008	-	4.3750	5.5007	.688			5/8-11			BA-10-08
12-1/2"	A2-6	4.0551	1500	121	PS3-12"/A2-6	1-211-1206	5.2520	-	4.1880	.630	4.6338	2.244	1/2-13	4-3/4	6	BA-12-06
	A1-8	3.1496			PS3-12"/A1-8	1-211-1208	-	4.3750	5.5007	.688			5/8-11			BA-12-08
15-3/4"	A2-8	4.0551	1000	203	PS3-16"/A2-8	1-211-1606	5.2520	-	4.1880	.630	5.0591	2.639	1/2-13	5	6	BA-16-06
	A1-8	5.3543			PS3-16"/A1-8	1-211-1608	6.7480	-	5.5007	.709			5/8-11			BA-16-08
20"	A1-11	5.1181	700	353	PS3-16"/A1-11	1-211-1611	-	6.5000	7.7507	.750	7.507	3.5039	3/4-10	4-1/4	6	BA-16-11
	A2-11	7.5905			PS3-20"/A2-11	1-211-2011	9.2520	-	7.7507	.787			5/8-11			BA-20-11
25"	A2-11	7.490	500	628	PS3-25"/A2-11	1-211-2511	9.2520	-	7.7507	.787	6.4961	3.4646	3/4-10	7-3/32	6	BA-25-11

\*C-C1, depth of counterbore.

**▶ 3-Jaw ,Type L, Direct Mount Self-Centering Scroll Chucks With Two Piece Hard Reversible Jaws,Medium Duty**

- Semi- steel body.



Type L

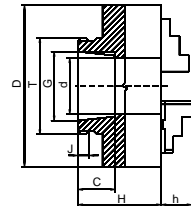

Chuck Dia.(D)	Taper Size	Hole Dia.(d)	RPM max*	wt. lbs.	Model	Chuck Part No .	Thread T	G	J	C	H	h
6-1/4"	L00	1.6535	3000	23	PS3-6"/A/L00	1-241-0601	3-3/4" -6	2-3/4	.5512	2.1260	4.0551	1.693
	L0				PS3-6"/A/L0	1-241-0602	4-1/2" -6	3-1/4	.5906	2.5197	4.4488	
8"	L00	2.1654	2500	42	PS3-8"/A/L00	1-241-0801	3-3/4" -6	2-3/4	.5512	2.1260	4.3701	1.772
	L0				PS3-8"/A/L0	1-241-0802	4-1/2" -6	3-1/4	.5906	2.5197	4.7638	
	L1				PS3-8"/A/L1	1-241-0803	6" -6	4-1/8	.6299	2.9921	5.2362	
10"	L0	2.9921	2000	64	PS3-10"/A/L0	1-241-1002	4-1/2" -6	3-1/4	.5906	2.5197	5.0394	2.087
	L1				PS3-10"/A/L1	1-241-1003	6" -6	4-1/8	.6299	2.9921	5.5118	
	L2				PS3-10"/A/L2	1-241-1004	7-3/4" -5	5-1/4	.8661	3.5039	6.0236	
12-1/2"	L1	4.0551	1500	134	PS3-12"/A/L1	1-241-1203	6" -6	4-1/8	.6299	2.9921	5.8661	2.244
	L2				PS3-12"/A/L2	1-241-1204	7-3/4" -5	5-1/4	.8661	3.5039	6.3780	
15-3/4"	L1	4.0551	1000	251	PS3-16"/A/L1	1-241-1603	6" -6	4-1/8	.6299	2.9921	6.1811	2.639
	L2				PS3-16"/A/L2	1-241-1604	7-3/4" -5	5-1/4	.8661	3.5039	6.6929	

## PS Series Universal Chucks

### ▶ 3-Jaw ,Type D1, Direct Mount Self-Centering Scroll Chucks With Two Piece Hard Reversible Jaws,Medium Duty

- Semi-steel body.



Type D1

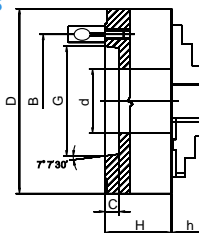

Chuck Dia.	Taper Size	Hole Dia.(d)	Max.Hole Enlargement	RPM max.	wt. lbs.	Model	Chuck Part No .	B	G	C	H	h	Camlock Studs		
													Dia.	Thread	Qty.
5"	D1-4	1.2598	1.2598	3200	11	PS3-5"AD/1-4	1-221-0504	3.2520	2.5005	.5118	2.7559	1.575	5/8	M10x1	3
6-1/4"	D1-3	1.6535	1.9685	3000	20	PS3-6"AD/1-3	1-221-0603	2.7795	2.1250	.5118	3.2087	1.693	9/16	M10x1	
	D1-4					PS3-6"AD/1-4	1-221-0604	3.2520	2.5005				5/8	M10x1	
8"	D1-3	2.0275	2.0275	2500	42	PS3-8"AD/1-3	1-221-0803	2.7795	2.1250	.5118	3.5827	1.772	9/16	M10x1	6
	D1-4	2.3622	PS3-8"AD/1-4			1-221-0804	3.2520	2.5005	5/8				M12x1		
	D1-5	2.1653	2.6378			PS3-8"AD/1-5	1-221-0805	4.1260	3.2505				3/4	M12x1	
	D1-6	2.6378	PS3-8"AD/1-6			1-221-0806	5.2520	4.1880	7/8				M16x1.5		
10"	D1-5	2.9922	3.7402	2000	71	PS3-10"AD/1-5	1-221-1005	4.1260	3.2505	.5629	4.0748	2.087	3/4	M12x1	6
	D1-6	2.9921	3.7402			PS3-10"AD/1-6	1-221-1006	5.2520	4.1880	.6299			7/8	M16x1.5	
	D1-8	3.7402	PS3-10"AD/1-8			1-221-1008	6.7480	5.5007	.7087	1			M20x1.5		
12-1/2"	D1-6	4.0551	4.0551	1500	112	PS3-12"AD/1-6	1-221-1206	5.2520	4.1880	.6299	4.6338	2.244	7/8	M16x1.5	6
	D1-8	4.0551	4.5276			PS3-12"AD/1-8	1-221-1208	6.7480	5.5007	.7087	4.6338		1	M20x1.5	
	D1-11	4.500	PS3-12"AD/1-11			1-221-1211	9.2520	7.7507	.7874	5.5118	1-3/16		M22x1.5		
15-3/4"	D1-6	4.0551	4.0551	1000	223	PS3-16"AD/1-6	1-221-1606	5.2520	4.1880	.6299	5.0591	2.639	7/8	M16x1.5	6
	D1-8	5.3543	5.3543			PS3-16"AD/1-8	1-221-1608	6.7480	5.5007	.7087			1	M20x1.5	
	D1-11	5.3543	5.9055			PS3-16"AD/1-11	1-221-1611	9.2520	7.7507	.7874			1-3/16	M22x1.5	
20"	D1-8	5.3543	5.3543	700	331	PS3-20"AD/1-8	1-221-2008	6.7480	5.5007	.7087	5.6693	3.5039	1	M20x1.5	6
	D1-11	7.5905	7.5984			PS3-20"AD/1-11	1-221-2011	9.2520	7.7507	.7874			1-3/16	M22x1.5	
25"	D1-11	7.5905	7.5984	500	604	PS3-25"AD/1-11	1-221-2511	9.2520	7.7507	.7874	6.4961	3.4646	1-3/16	M22x1.5	

### ▶ 2-Jaw Scroll Chucks with Soft Top Reversible Jaws Semi-Steel Body, Plain back

Chuck Dia.	Hole Dia.	Max.Hole Enlargements	RPM max.	Model	Part No.
6-1/4"	1.6535	1.9252	3000	PS2-6"S	1-205-0600
8"	2.1654	2.8189	2500	PS2-8"S	1-205-0800
10"	2.9921	3.5827	2000	PS2-10"S	1-205-1000
12-1/2"	4.0551	4.4882	1500	PS2-12"S	1-205-1200
15-3/4"	5.3543	5.7480	1000	PS2-16"S	1-205-1600

Each chuck is provided with:

- 1 set of hard master jaws
- 1 set of soft top reversible jaws
- 1 set of mounting bolts
- 1 chuck wrench
- 2 hex keys
- eye bolts (10" and larger)
- 2 pinion design



Dimension for 2-jaw scroll chuck please see page 21.

### ▶ SPARE PART for PS series universal chucks ◀

Chuck Dia.	Scroll plate	Pinion	Wrench *	Pinion Screw
3-1/4"	SC-PS-080	PI-PS-080	W-P-080	PH-P-080
4"	SC-PS-100	PI-PS-100	W-P-125	PH-P-100
5"	SC-PS-125	PI-PS-125	W-P-125	PH-P-125
6-1/4"	SC-PS-160	PI-PS-160	W-P-200	PH-P-160
8"	SC-PS-200	PI-PS-200	W-P-200	PH-P-200
10"	SC-PS-250	PI-PS-250	W-P-315	PH-P-250
12-3/2"	SC-PS-315	PI-PS-315	W-P-315	PH-P-315
15-3/4"	SC-PS-400	PI-PS-400	W-P-400	PH-P-400
20"	SC-PS-500	PI-PS-500	W-P-630	PH-P-500
25"	SC-PS-630	PI-PS-630	W-P-630	PH-P-630
32"	SC-PS-800	PI-PS-800	W-P-800	PH-P-800



■ Scroll Plate



■ Pinion



■ Wrench



■ Pinion Screw

- Sold by piece. \*W-SP- Extended Wrenches available from stock.

## SPARE PARTS



■ Sold in set.



■ Sold by piece.



■ Sold in set.

Chuck	Hard Top Jaws		Soft Top Jaws		Hard Master Jaws		
	3-Jaw	4-Jaw	2-Jaw	3-Jaw & 4-Jaw	2-Jaw	3-Jaw	4-Jaw
5"	TJ-PS3-125	TJ-PS4-125	-	STJ-PS1-125	-	MJ-PS3-125	MJ-PS4-125
6-1/4"	TJ-PS3-160	TJ-PS4-160	STJ-PS2-160	STJ-PS1-160	MJ-PS2-160	MJ-PS3-160	MJ-PS4-160
8"	TJ-PS3-200	TJ-PS4-200	STJ-PS2-200	STJ-PS1-200	MJ-PS2-200	MJ-PS3-200	MJ-PS4-200
10"	TJ-PS3-250	TJ-PS4-250	STJ-PS2-250	STJ-PS1-250	MJ-PS2-250	MJ-PS3-250	MJ-PS4-250
12-1/2"	TJ-PS3-315	TJ-PS4-315	STJ-PS2-315	STJ-PS1-315	MJ-PS2-315	MJ-PS3-315	MJ-PS4-315
15-3/4"	TJ-PS3-400	TJ-PS4-400	STJ-PS2-400	STJ-PS1-400	MJ-PS2-400	MJ-PS3-400	MJ-PS4-400
20"	TJ-PS3-500	TJ-PS4-500	-	STJ-PS1-500	-	MJ-PS3-500	MJ-PS4-500
25"	TJ-PS3-630	TJ-PS4-630	-	STJ-PS1-630	-	MJ-PS3-630	MJ-PS4-630
32"	TJ-PS3-630	-	-	STJ-PS1-630	-	MJ-PS3-800	-



■ Sold in set.



■ Sold in set.



■ Sold in set.

Chuck	I.D. Hard Solid Jaws		O.D. Hard Solid Jaws		Soft Solid Jaws	
	3-Jaw	4-Jaw	3-Jaw	4-Jaw	3-Jaw	4-Jaw
3-1/4"	OJ-PS3-80	-	IJ-PS3-80	-	SJ-PS3-80	-
4"	OJ-PS3-100	-	IJ-PS3-100	-	SJ-PS3-100	-
5"	OJ-PS3-125	OJ-PS4-125	IJ-PS3-125	IJ-PS4-125	SJ-PS3-125	SJ-PS4-125
6-1/4"	OJ-PS3-160	OJ-PS4-160	IJ-PS3-160	IJ-PS4-160	SJ-PS3-160	SJ-PS4-160
8"	OJ-PS3-200	OJ-PS4-200	IJ-PS3-200	IJ-PS4-200	SJ-PS3-200	SJ-PS4-200
10"	OJ-PS3-250	OJ-PS4-250	IJ-PS3-250	IJ-PS4-250	SJ-PS3-250	SJ-PS4-250
12-1/2"	OJ-PS3-315	OJ-PS4-315	IJ-PS3-315	IJ-PS4-315	SJ-PS3-315	SJ-PS4-315
15-3/4"	OJ-PS3-400	OJ-PS4-400	IJ-PS3-400	IJ-PS4-400	-	-
20"	OJ-PS3-500	-	IJ-PS3-500	-	-	-

## Camlock Studs

■ Sold by piece.

Taper Size	Camlock Studs			No. of Studs
	Dia.	Thread	Part No.	
D1-3	9/16"	M10 x 1	CA-D-03	3
D1-4	5/8"		CA-D-04	
D1-5	3/4"	M12 x 1	CA-D-05	
D1-6	7/8"	M16 x 1.5	CA-D-06	6
D1-8	1"	M20 x 1.5	CA-D-08	
D1-11	1-3/16"	M22 x 1.5	CA-D-11	
D1-15	1-3/8"	M24 x 1.5	CA-D-15	



## Mounting Bolts for Hard & Soft Top Jaws

■ Sold by piece.

Chuck Dia.	Thread	Screw No. 1		Screw No. 2	
		Short Screw		Long Screw	
		L	Part No.	L	Part No.
5"	5/16-18	.79	MT-J1-5	1.00	MT-J2-5
6"	3/8-16		MT-J1-6	1.18	MT-J2-6
8"			MT-J1-6		MT-J2-6
10" & 12"	1/2-13	1.00	MT-J1-10	1.57	MT-J2-10
16"	5/8-11	1.00	MT-J1-16	1.57	MT-J2-16
20"	3/4-10	1.57	MT-J1-20	3.15	MT-J2-25
25"			MT-J1-20	3.15	MT-J2-25
32"			MT-J1-20	3.15	MT-J2-25

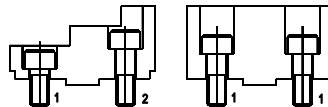





## I.D. Hard Solid Jaws for 2,3,4 & 6 Jaw PA,PO,PS Series Scroll Chucks

- Sold in sets.

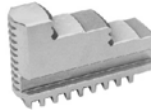

Chuck Dia.	C	L	B	F	E	N	P	O	wt./pc. Lbs.
3-1/4"	1.1024	1.2598	.4331	.2362	.2362	.2362	0.827	.374	.10
4"	1.2598	1.6535	.5906	.2362	.2362	.2756	1.063	.433	.19
5"	1.5748	2.0079	.7874	.3150	.3150	.3150	1.313	.512	.40
6-1/4"	2.0866	2.7559	.7874	.3150	.3150	.3937	1.772	.748	.80
8"	2.1260	3.3459	.9843	.3543	.3937	.4724	2.244	.906	1.07
10"	2.4803	4.1339	1.1024	.4331	.4724	.5512	2.736	1.102	1.73
12-1/2"	2.9528	4.9213	1.2598	.5000	.4724	.7087	3.268	1.358	2.90
15-3/4"	3.6220	5.7087	1.4173	.5906	.5512	.8661	3.898	1.417	5.20
20"	3.9370	7.0866	1.5748	.6299	.5512	1.0236	4.705	1.969	7.33

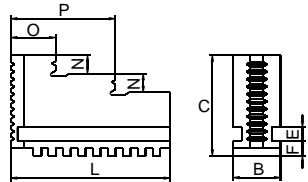

## O.D. Hard Solid Jaws for 2,3,4 & 6 Jaw PA,PO,PS Series Scroll Chucks

- Sold in sets.



Chuck Dia.	C	L	B	F	E	N	P	O	wt./pc. Lbs.
3-1/4"	1.1024	1.2598	.4331	.2362	.2362	.2362	0.827	.374	.10
4"	1.2598	1.6535	.5906	.2362	.2362	.2756	1.063	.433	.19
5"	1.5748	2.0079	.7874	.3150	.3150	.3150	1.313	.512	.40
6-1/4"	2.0866	2.7559	.7874	.3150	.3150	.3937	1.772	.748	.80
8"	2.1260	3.3459	.9843	.3543	.3937	.4724	2.244	.906	1.07
10"	2.4803	4.1339	1.1024	.4331	.4724	.5512	2.736	1.102	1.73
12-1/2"	2.9528	4.9213	1.2598	.5000	.4724	.7087	3.268	1.358	2.90
15-3/4"	3.6220	5.7087	1.4173	.5906	.5512	.8661	3.898	1.417	5.20
20"	3.9370	7.0866	1.5748	.6299	.5512	1.0236	4.705	1.969	7.33

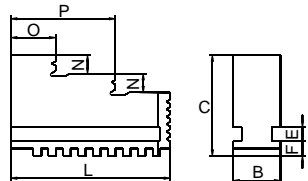

## Soft Solid Jaws for 2,3,4 & 6 Jaw PA,PO,PS Series Scroll Chucks

- Sold in sets.



Chuck Dia.	C	L	B	F	E	N	P	O	wt./pc. Lbs.
3-1/4"	1.1024	1.2598	.4331	.2362	.2362	.2362	0.827	.374	.13
4"	1.2598	1.6535	.5906	.2362	.2362	.2756	1.063	.433	.29
5"	1.5748	2.0079	.7874	.3150	.3150	.3150	1.313	.512	.57
6-1/4"	2.0866	2.7559	.7874	.3150	.3150	.3937	1.772	.748	1.10
8"	2.1260	3.3459	.9843	.3543	.3937	.4724	2.244	.906	1.77
10"	2.4803	4.1339	1.1024	.4331	.4724	.5512	2.736	1.102	3.00
12-1/2"	2.9528	4.9213	1.2598	.5000	.4724	.7087	3.268	1.358	4.20

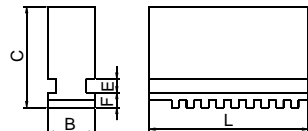



## PS Series Universal Chucks

### ► FL Series Cast-iron Adapter, Semi-Machined for PO & PS Series Chucks



Type A

Type D

Chuck Dia.	Taper No	O.D.	TYPE A (A1,A2) Part No.	TYPE D Part No.
5"	3	4.92	--	FL-125/D3
5"	4	4.92	--	FL-125/D4
6-1/4"	3	6.30	--	FL-160/D3
6-1/4"	4	6.30	--	FL-160/D4
6-1/4"	5	6.30	FL-160/A5	FL-160/D5
8"	4	7.87	FL-200/A4	FL-200/D4
8"	5	7.87	FL-200/A5	FL-200/D5
8"	6	7.87	FL-200/A6	FL-200/D6
10"	5	9.87	FL-250/A5	FL-250/D5
10"	6	9.87	FL-250/A6	FL-250/D6
10"	8	9.87	FL-250/A8	FL-250/D8
12-1/2"	6	12.40	FL-315/A6	FL-315/D6
12-1/2"	8	12.40	FL-315/A8	FL-315/D8
12-1/2"	11	12.40	FL-315/A11	FL-315/D11
15-3/4"	6	15.83	FL-400/A6	FL-400/D6
15-3/4"	8	15.83	FL-400/A8	FL-400/D8
15-3/4"	11	15.83	FL-400/A11	FL-400/D11
20"	8	19.80	FL-500/A8	FL-500/D8
20"	11	19.80	FL-500/A11	FL-500/D11
20"	15	19.80	FL-500/A15	FL-500/D15
25"	8	24.80	FL-630/A8	FL-630/D8
25"	11	24.80	FL-630/A11	FL-630/D11
25"	15	24.80	FL-630/A15	FL-630/D15



Type L

Threaded

Chuck Dia.	O.D.	Taper Size	Thread T - UNS3	Part No.
6-1/4"	6.30	L00	3-3/4 - 6	FL-160/L00
		L0	4-1/2 - 6	FL-160/L0
8"	7.87	L00	3-3/4 - 6	FL-200/L00
		L0	4-1/2 - 6	FL-200/L0
		L1	6 - 6	FL-200/L1
10"	9.87	L00	3-3/4 - 6	FL-250/L00
		L0	4-1/2 - 6	FL-250/L0
		L1	6 - 6	FL-250/L1
12-1/2"	12.40	L0	4-1/2 - 6	FL-315/L0
		L1	6 - 6	FL-315/L1
		L2	7-3/4 - 5	FL-315/L2
15-3/4"	15.83	L1	6 - 6	FL-400/L1
		L2	7-3/4 - 5	FL-400/L2
		L3	10-3/8 - 4	FL-400/L3
20"	19.80	L2	7-3/4 - 5	FL-500/L2

Chuck Dia.	O.D.	Thread d	Part No.
4"	3.94	1-10 UNS-2B	FL-100/T1
		1-1/2 - 8 UN-2B	FL-100/T2
5"	4.92	1-1/8 - 12W	FL-125/T3
		1-1/2 - 8 UN-2B	FL-125/T2
		2-3/16 - 10 Hardinge	FL-125/T4
		2-1/4 - 8 UN-2B	FL-125/T5
6-1/4"	6.30	1-1/2 - 8 UN-2B	FL-160/T2
		2-3/16 - 10 Hardinge	FL-160/T4
		2-1/4 - 8 UN-2B	FL-160/T5
8"	7.87	1-1/2 - 8 UN-2B	FL-200/T2
		2-1/4 - 8 UN-2B	FL-200/T5
		2-3/8 - 6 UN-2B	FL-200/T6
10"	9.87	2-3/8 - 6 UN-2B	FL-250/T6
12-1/2"	12.40	2-3/8 - 6 UN-2B	FL-315/T6

► **FLD Series Cast-iron Adapter, Machined \***  
for PO & PS Series Chucks

\*Note: Skim cut on the face of the adapter flange and boss required.



Type A



Type D



Chuck Dia.	Taper No	O.D.	TYPE A (A1,A2) Part No.	TYPE D Part No.
5"	3	4.92	--	FLD-125/D3
5"	4	4.92	--	FLD-125/D4
6-1/4"	3	6.30	--	FLD-160/D3
6-1/4"	4	6.30	--	FLD-160/D4
6-1/4"	5	6.30	FLD-160/A5	FLD-160/D5
8"	4	7.87	FLD-200/A4	FLD-200/D4
8"	5	7.87	FLD-200/A5	FLD-200/D5
8"	6	7.87	FLD-200/A6	FLD-200/D6
10"	5	9.87	FLD-250/A5	FLD-250/D5
10"	6	9.87	FLD-250/A6	FLD-250/D6
10"	8	9.87	FLD-250/A8	FLD-250/D8
12-1/2"	6	12.40	FLD-315/A6	FLD-315/D6
12-1/2"	8	12.40	FLD-315/A8	FLD-315/D8
12-1/2"	11	12.40	FLD-315/A11	FLD-315/D11
15-3/4"	6	15.83	FLD-400/A6	FLD-400/D6
15-3/4"	8	15.83	FLD-400/A8	FLD-400/D8
15-3/4"	11	15.83	FLD-400/A11	FLD-400/D11
20"	8	19.80	FLD-500/A8	FLD-500/D8
20"	11	19.80	FLD-500/A11	FLD-500/D11
20"	15	19.80	FLD-500/A15	FLD-500/D15
25"	8	24.80	FLD-630/A8	FLD-630/D8
25"	11	24.80	FLD-630/A11	FLD-630/D11
25"	15	24.80	FLD-630/A15	FLD-630/D15



Type L

Chuck Dia.	O.D.	Taper Size	Thread T - UNS3	Part No.
6-1/4"	6.30	L00	3-3/4 - 6	FLD-160/L00
		L0	4-1/2 - 6	FLD-160/L0
8"	7.87	L00	3-3/4 - 6	FLD-200/L00
		L0	4-1/2 - 6	FLD-200/L0
		L1	6 - 6	FLD-200/L1
10"	9.87	L00	3-3/4 - 6	FLD-250/L00
		L0	4-1/2 - 6	FLD-250/L0
		L1	6 - 6	FLD-250/L1
12-1/2"	12.40	L0	4-1/2 - 6	FLD-315/L0
		L1	6 - 6	FLD-315/L1
		L2	7-3/4 - 5	FLD-315/L2
		L1	6 - 6	FLD-400/L1
15-3/4"	15.83	L2	7-3/4 - 5	FLD-400/L2
		L3	10-3/8 - 4	FLD-400/L3
		L2	7-3/4 - 5	FLD-500/L2



# Front Mounting Scroll Chucks

3 Jaw & 4 Jaw Self-Centering  
Forged Steel & Semi-Steel body  
Plain Back  
Medium Duty



- 3 & 4 Jaw Scroll Chucks with semi-steel and forged steel body Are designed for use with all rotary tables and other devices Where back mounting chucks cannot be used. They can be mounted directly on 3/6 slot rotary tables or on a base plate when the rotary table has 3/6 or 4/8 T-slots.
- Base plates are designed for use with Gator 3 & 4 Jaw, Front Mounting, Self-centering Lathe chuck.

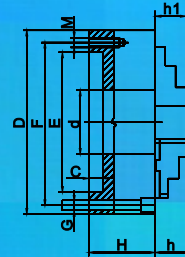

## Front Mounting Self-centering 3&4 Jaw scroll chuck

### Principal Dimensions

Chuck Dia.(D)	F	E(H7)	d	C	H		h	h1	Screws			
					PS	PO			Thread (G)	Qty.	Thread (M)	Qty.
3-1/4"	2.6378	2.2047	0.6299	0.1181	1.732	1.732	-	0.512	1/4-20x1.97	3	M6	3
4"	3.2677	2.7559	0.7874	0.1181	1.969	1.969	-	0.669	5/16-18x2.17	3	M8	3
5"	4.2520	3.7402	1.2598	0.1575	2.205	2.422	1.575	0.787	5/16-18x2.17	3	M8	3
6-1/4"	5.5118	4.9213	1.6535	0.1575	2.559	2.756	1.693	1.260	3/8-16x2.76	3	M10	3
8"	6.9291	6.2992	2.1654	0.1575	2.953	3.150	1.772	1.142	3/8-16x3.15	3	M10	3
10"	8.8189	7.8740	2.9921	0.1969	3.347	3.543	2.087	1.339	1/2-13x3.54	3	M12	3
12-1/2"	11.2598	10.2362	4.0551	0.1969	3.701	3.937	2.244	1.693	5/8-11x3.94	3	M16	3
15-3/4"	14.2519	12.9921	5.3543	0.1969	4.134	4.331	2.639	2.165	5/8-11x4.53	3	M16	3

### 3 Jaw & 4 Jaw Front Mounting Scroll Chucks Plain Back, Semi-Steel Body

Chuck Dia.	2-Piece Reversible Jaws		Hard Solid Jaws		2-Piece Reversible Jaws	
	Model	Part No.	Model	Part No.	Model	Part No.
3-1/4"	-	-	PS3-3"(F)	1-202-0301	-	-
4"	-	-	PS3-4"(F)	1-202-0401	-	-
5"	PS3-5"(A)(F)	1-201-0501	PS3-5"(F)	1-202-0501	-	-
6-1/4"	PS3-6"(A)(F)	1-201-0601	PS3-6"(F)	1-202-0601	PS4-6"(A)(F)	1-203-0601
8"	PS3-8"(A)(F)	1-201-0801	PS3-8"(F)	1-202-0801	PS4-8"(A)(F)	1-203-0801
10"	PS3-10"(A)(F)	1-201-1001	-	-	PS4-10"(A)(F)	1-203-1001
12-1/2"	PS3-12"(A)(F)	1-201-1201	-	-	PS4-12"(A)(F)	1-203-1201
15-3/4"	PS3-16"(A)(F)	1-201-1601	-	-	PS4-16"(A)(F)	1-203-1601

\*\*PS3 for 3 jaw; PS4 for 4 jaw.

### Steel Body 3-Jaw Front Mounting Scroll Chucks Plain Back

Chuck Dia.	2-Piece Reversible Jaws	
	Model	Part No.
3-1/4"	PO3-3"(F) *	1-106-0301*
4"	PO3-4"(F) *	1-106-0401*
5"	PO3-5"(A)(F)	1-105-0501
6-1/4"	PO3-6"(A)(F)	1-105-0601
8"	PO3-8"(A)(F)	1-105-0801
10"	PO3-10"(A)(F)	1-105-1001
12-1/2"	PO3-12"(A)(F)	1-105-1201

\* for hard solid jaws

# PSL Series Chucks

3 Jaw Self-Centering  
 Forged steel body, Large Thru-hole  
 Plain back  
 Medium Duty

- Two-piece Reversible American Standard Tongue and Groove Jaws.
- Designed for pipe machining or pipe weld-ing cut-off operations.
- Can be used on lathes, rotary tables and welding devices.
- Jaws, scroll plate, and three pinions are made of fine alloy steel, then carefully heat-treated and ground.
- Balanced scroll.
- Front mounting option is available.

## Standard Accessories:

- 1 set of master jaws
- 1 set of hard top jaws
- 1 chuck wrench
- 1 set of mounting screws
- 2 hex keys
- 2 lifting eye bolts

## Optional Accessories:

- Soft top jaws
- Adapter plates, semi-finished for 15-3/4", 20", & 26" diameter chucks only.

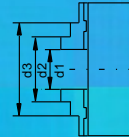
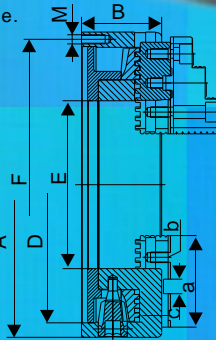

Chuck Dia.	d1		d2		d3	
	Min.	Max.	Min.	Max.	Min.	Max.
15-3/4"	5.12	10.63	9.06	13.78	11.81	15.75
20"	9.84	14.96	12.99	17.72	15.16	19.69
26"	14.80	18.50	17.91	22.64	20.28	25.00
31-1/2"	10.24	22.28	14.17	29.53	16.54	31.50

## Principal Dimensions

Chuck Dia. A	Thru Hole E	Jaw Stroke		wt. of Workpiece		B	F	D H7	a	M	b	c	wt. lbs.	Max. RPM	Model	Part No.
		min.	max.	without support	with support											
15-3/4"	8.66	6.614	11.34	110	3307	4.13	15.000	14.252	4.72	M12 x 40	5/8"-11	.74996	128	650	PSL3-16"	1-207-1600
20"	12.60	9.874	14.96	177	5512	4.72	18.957	18.189	4.72	M16 x 40	3/4"-10		168	460	PSL3-20"	1-207-2000
26"	15.98	14.80	19.57	265	7716	5.32	24.409	22.835	5.00	M16 x 40	3/4"-10		258	325	PSL3-26"	1-207-2600
31-1/2"	16.14	17.42	22.28	441	8820	5.95	18.110	27.953	8.86	M24 x 160	3/4"-10		468	260	PSL3-32"	1-207-3200

## Spare parts



Chuck Dia.	Hard Master Jaws 3 pcs./set	Hard Top Jaws 3 pcs./set	Soft Top Jaw 1 pc	Scroll 1 pc	Pinion 1 pc	Wrench 1 pc	Pinion Screw 1 pc.	Chuck Mounting Bolts, 1 pc.
Part No.								
15-3/4"	MJ-PSL-400	TJ-PS3-400	STJ-PS1-400	SC-PL-400	PI-PL-400	W-PL-400	PH-L-508	MB-PL-400
20"	MJ-PSL-508	TJ-PS3-500	STJ-PS1-500	SC-PL-508	PI-PL-508	W-PL-500		MB-PL-508
26"	MJ-PSL-660	TJ-PS3-630	STJ-PS1-630	SC-PL-660	PI-PL-660	W-PL-630		MB-PL-660
31-1/2"	MJ-PSL-800	TJ-PS3-630	STJ-PS1-630	SC-PL-800	PI-PL-800	W-PL-800		MB-PL-800

**gator chucks™**  
 BY FUERDA

# PI Series Independent Chucks, Medium Duty

## 4-Jaw Independent Chucks

Solid Reversible Jaws or Hard 2-Piece Reversible Jaws

Semi-steel Body

4-Jaw Independent Chucks are designed to grip round or odd shaped work.

Medium duty chucks have hard solid reversible jaws or hard 2-piece reversible jaws. The jaws are made of high quality carbon steel and are hardened.

All 10" chucks & larger are provided with the T-Slots.

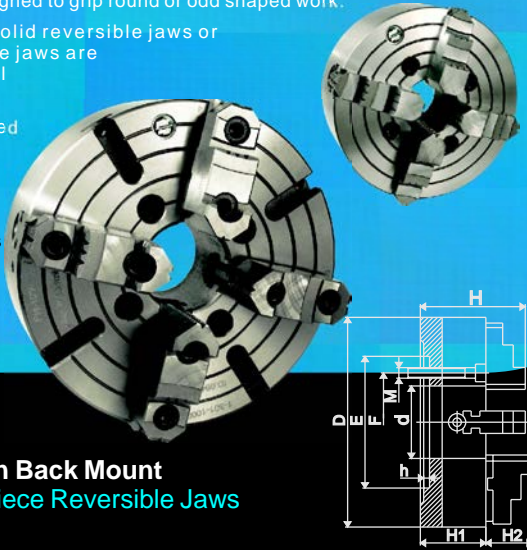

### Standard Accessories:

- 1 set of hard reversible jaws  
Or 1set of hard top jaws and hard master jaws
- 1 T-wrench,
- 1 L-wrench for 40" & 50" chucks only
- 2 hex keys
- 2 eye bolts for chucks 10" & larger
- 1set of mounting bolts

### ▶ 4-Jaw Independent Chucks, Plain Back Mount Solid Reversible Jaws or Hard 2-Piece Reversible Jaws Semi-steel Body

Chuck Dia. (D)	E (H7)	F	Hole(d)	H	H1	h	z-d		RPM Max.	Solid Jaws	
							Thread	Qty.		Weight lbs	Part No .
3-1/4"	2.165	2.598	0.866	1.654	2.283	0.138	M6	4	4000	4	1-302-0300
4"	2.835	3.307	0.984	2.126	3.031	0.157	M8	4	4000	7	1-302-0400
5"	3.740	4.252	1.181	2.205	3.071	0.177	M8	4	3500	11	1-302-0500
6-1/4"	2.559	3.740	1.772	2.559	3.799	0.196	M10	4	3200	16	1-302-0600
8"	2.953	3.740	2.205	2.953	4.331	0.236	M10	4	1800	22	1-302-0800
10"	5.906	4.126	2.559	3.347	4.700	0.276	M12	4	1500	55	1-302-1000
12-1/2"	6.890	5.252	3.150	3.740	5.701	0.276	M16	4	1200	86	1-302-1200
15-3/4"	7.874	6.748	3.937	4.134	6.095	0.394	M16	4	800	134	1-302-1600
20"	10.630	9.252	4.921	4.724	7.070	0.472	M20	4	500	231	1-302-2000
25"	10.630	9.252	6.299	5.512	7.866	0.472	M20	4	400	359	1-302-2500
32"	9.843	11.811	8.268	5.709	8.268	0.472	M20	8	300	703	1-302-3200
40"*	12.598	14.567	10.236	5.906	9.488	0.591	M20	8	150	816	1-302-4000
50"*	15.748	19.685	7.087	6.496	10.074	0.591	M20	8	100	1543	1-302-5000

Chuck Dia. (D)	E (H7)	F	Hole(d)	Hole Enlargement	H	H2	h	z-d		RPM Max.	Two-Piece Jaws	
								Thread	Qty.		Weight lbs	Part No .
8"	2.953	3.740	2.205	2.283	2.953	1.8268	0.236	M10	4	1800	22	1-301-0800
10"	5.906	4.126	2.559	2.992	3.347	2.3780	0.276	M12	4	1500	55	1-301-1000
12-1/2"	6.890	5.252	3.150	3.937	3.740	2.3980	0.276	M16	4	1200	86	1-301-1200
15-3/4"	7.874	6.748	3.937	4.881	4.134	2.8465	0.394	M16	4	800	134	1-301-1600
20"	10.630	9.252	4.921	6.299	4.724	3.5551	0.472	M20	4	500	231	1-301-2000
25"	10.630	9.252	6.299	7.087	5.512	3.8504	0.472	M20	4	400	359	1-301-2500
32"	9.843	11.811	8.268	-	5.709	3.6929	0.472	M20	8	300	703	1-301-3200
40"*	12.598	14.567	10.236	-	5.906	4.6850	0.591	M20	8	150	816	1-301-4000
50"*	15.748	19.685	7.087	10.236	6.496	4.6850	0.591	M20	8	100	1543	1-301-5000

\*Cast steel body



## PI Series Independent Chucks

**gator chucks™**  
BY FUERDA

### ► Direct Mount 4-Jaw Independent Chucks, Type A1/A2 Solid Reversible Jaws, Semi-steel Body



Type A

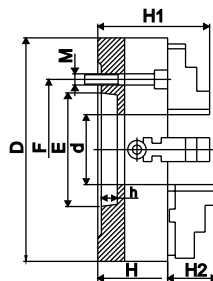

Chuck Dia.(D)	Taper No.	E	F	d	H1	H	h	(M) Spindle Mounting Bolts			RPM Max.	Weight lbs	Part No.
								Thread	L	Qty.			
8"	A2-5	3.251	4.125	2.205	4.331	2.953	0.512	7/16"-14	3-1/8	4	1800	38	1-312-0805
	A2-5	3.251	4.125					7/16"-14	3-1/8	4			1-312-1005
10"	A2-6	4.188	5.250	2.559	4.700	3.347	0.591	1/2"-13	3-1/8	4	1500	55	1-312-1006
	A2-8	5.501	6.750					5/8"-11	3-3/8	4			1-312-1008
12-1/2"	A2-5	3.251	4.125	3.091	5.701	3.740	0.512	7/16"-14	3-1/2	4	1200	86	1-312-1205
	A2-6	4.188	5.250					1/2"-13	3-1/2	4			1-312-1206
15-3/4"	A2-8	5.501	6.750	3.150	5.701	3.740	0.709	5/8"-11	3-1/4	4	800	140	1-312-1208
	A2-6	4.188	5.250					1/2"-13		4			1-312-1606
20"	A2-8	5.501	6.750	3.937	6.095	4.134	0.709	5/8"-11		4	500	245	1-312-1608
	A2-11	7.751	9.252					3/4"-10		4			1-312-1611
25"	A2-8	5.501	6.750	4.921	7.070	4.724	0.709	5/8"-11		4	400	358	1-312-2008
	A2-11	7.751	9.252					3/4"-10		4			1-312-2011
32"	A2-11	7.751	9.252	6.299	7.866	5.512	0.787	3/4"-10		4	300	672	1-312-2511
	A2-15	11.251	13.00					7/8"-9	5-5/16	4			1-312-2515
40"	A2-11	7.751	9.252	7.087	8.268	5.315	0.787	3/4"-10	5-7/8	8	150	780	1-312-3211
	A2-15	11.251	13.00					7/8"-9	6-1/8	8			1-312-3215
40"	A2-11	7.751	9.252	7.087	9.488	5.906	0.787	3/4"-10	7-3/32	8	150	780	1-312-4011
	A2-15	11.251	13.00					7/8"-9	7-3/32	8			1-312-4015

\* Cast steel body

40" with A2-20 is available (Part No.: 1-312-4020) is available ; 50" with A2-11, A2-15, A2-20 are available.

### ► Direct Mount 4-Jaw Independent Chucks, Type D1 Solid Reversible Jaws, Semi-steel Body



Type D

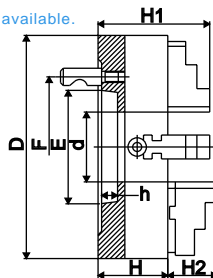

Chuck Dia.(D)	Taper No.	E	F	d	H1	H	h	(M) Spindle Mounting Bolts			RPM Max.	Weight lbs	Part No.
								Thread	L	Qty.			
8"	D1-4	2.501	3.252	2.205	4.331	2.953	0.5118	5/8	M10x1	3	1800	22	1-322-0804
	D1-5	3.251	4.126					0.5906	3/4	M12x1			6
10"	D1-4	2.501	3.252	2.362	4.700	3.347	0.5118	5/8	M10x1	3	1500	60	1-322-1004
	D1-5	3.251	4.126					0.5906	3/4	M12x1			6
12-1/2"	D1-6	4.188	5.252	2.559	4.700	3.347	0.6299	7/8	M16x1.5	6	1200	87	1-322-1006
	D1-6	4.188	5.252					0.6299	7/8	M16x1.5			6
15-3/4"	D1-8	5.501	6.748	3.150	5.701	3.740	0.7087	1	M20x1.5	6	800	132	1-322-1208
	D1-6	4.188	5.252					0.6299	7/8	M16x1.5			6
20"	D1-8	5.501	6.748	3.937	6.095	4.134	0.7087	1	M20x1.5	6	500	211	1-322-1608
	D1-11	7.751	9.252					0.7874	1-3/16	M22x1.5			6
25"	D1-8	5.501	6.750	4.921	7.070	4.724	0.7087	1	M20x1.5	6	400	364	1-322-2008
	D1-11	7.751	9.252					0.7874	1-3/16	M22x1.5			6
32"	D1-11	7.751	9.252	6.299	7.866	5.512	0.7874	1-3/16	M22x1.5	6	400	364	1-322-2511
	D1-11	7.751	9.252					0.7874	1-3/16	M22x1.5			6

32" with D1-11 is available. Part No.: 1-322-3211.

## PI Series Independent Chucks

### ► Direct Mount 4-Jaw Independent Chucks, Type A1/A2

Hard 2-Piece Reversible Jaws  
Semi-steel Body



Type A

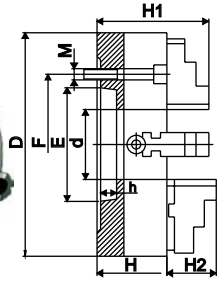

Chuck Dia. (D)	Taper No.	E	F	d	H1	H	h	(M) Spindle Mounting Bolts			RPM Max.	Weight lbs	Part No.	
								Thread	L	Qty.				
8"	A2-5	3.251	4.125	2.205	1.8268	2.953	0.512	7/16"-14	3-1/8	4	1800	38	1-311-0805	
	A2-5	3.251	4.125					7/16"-14	3-1/8	4		55	1-311-1005	
10"	A2-6	4.188	5.250	2.559	2.3780	3.347	0.591	1/2"-13	3-1/8	4	1500	55	1-311-1006	
	A2-8	5.501	6.750					0.709	5/8"-11	3-3/8		4	55	1-311-1008
12-1/2"	A2-5	3.251	4.125	3.091	2.3980	3.740	0.512	7/16"-14	3-1/2	4	1200	86	1-311-1205	
	A2-6	4.188	5.250					0.591	1/2"-13	3-1/2		4	86	1-311-1206
	A2-8	5.501	6.750					0.709	5/8"-11	3-1/4		4	86	1-311-1208
15-3/4"	A2-6	4.188	5.250	3.937	2.8465	4.134	0.591	1/2"-13		4	800	140	1-311-1606	
	A2-8	5.501	6.750					0.709	5/8"-11	4		4	140	1-311-1608
	A2-11	7.751	9.252					0.787	3/4"-10			4	140	1-311-1611
20"	A2-8	5.501	6.750	4.921	3.5551	4.724	0.709	5/8"-11		4	500	245	1-311-2008	
	A2-11	7.751	9.252					0.787	3/4"-10	4-1/2		4	245	1-311-2011
25"	A2-11	7.751	9.252	6.299	3.8504	5.512	0.787	3/4"-10		4	400	358	1-311-2511	
	A2-15	11.251	13.000					0.827	7/8"-9	5-5/16		4	358	1-311-2515
32"	A2-11	7.751	9.252	7.087	3.6929	5.315	0.787	3/4"-10	5-7/8	8	300	672	1-311-3211	
	A2-15	11.251	13.000					0.827	7/8"-9	6-1/8		8	672	1-311-3215
40"*	A2-11	7.751	9.252	7.087	4.6850	5.906	0.787	3/4"-10	7-3/32	8	150	780	1-311-4011	
	A2-15	11.251	13.000					0.827	7/8"-9	7-3/32		8	780	1-311-4015

\* Cast steel body

40" with A2-20 (Part No.: 1-311-4020) is available; 50" with A2-11, A2-15, A2-20 are available.

### ► Direct Mount 4-Jaw Independent Chucks, Type D1

Hard 2-Piece Reversible Jaws  
Semi-steel Body



Type D

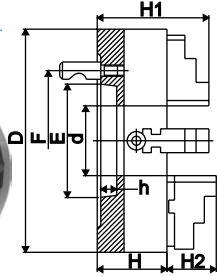
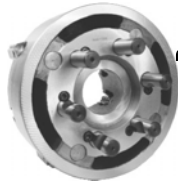

Chuck Dia. (D)	Taper No.	E	F	d	H1	H	h	(M) Spindle Mounting Bolts			RPM Max.	Weight lbs	Part No.		
								Thread	L	Qty.					
8"	D1-4	2.501	3.252	2.205	1.8268	2.953	0.5118	5/8	M10x1	3	1800	22	1-321-0804		
	D1-5	3.251	4.126					0.5906	3/4	M12x1		6	1800	22	1-321-0805
	D1-4	2.501	3.252					2.362	0.5118	5/8		M10x1	3	1500	60
10"	D1-5	3.251	4.126	2.559	2.3780	3.347	0.5906	3/4	M12x1	3	1500	60	1-321-1005		
	D1-6	4.188	5.252					0.6299	7/8	M16x1.5		6	1500	60	1-321-1006
	D1-6	4.188	5.252					0.6299	7/8	M16x1.5		6	1200	87	1-321-1206
12-1/2"	D1-8	5.501	6.748	3.150	2.3980	3.740	0.7087	1	M20x1.5	6	1200	87	1-321-1208		
	D1-6	4.188	5.252					0.6299	7/8	M16x1.5		6	800	132	1-321-1606
15-3/4"	D1-8	5.501	6.748	3.937	2.8465	4.134	0.7087	1	M20x1.5	6	800	132	1-321-1608		
	D1-11	7.751	9.252					0.7874	1-3/16	M22x1.5		6	800	132	1-321-1611
	D1-8	5.501	6.750					0.7087	1	M20x1.5		6	500	211	1-321-2008
20"	D1-11	7.751	9.252	4.921	3.5551	4.724	0.7874	1-3/16	M22x1.5	6	500	211	1-321-2011		
	D1-8	5.501	6.750					0.7874	1-3/16	M22x1.5		6	400	364	1-321-2511

32" with D1-11 is available. Part No.: 1-321-3211.



## FLI-Adapter Fully Machined for Independent chucks

\*Note: All these adapters do not require any additional machining.



A1/A2 Mount



D1 Mount



L Mount

### Clamping Range

Chuck Dia. (D)	A-A1	B-B1
3-1/4"	0.197-1.278	1.378-3.150
4"	0.236-1.772	1.575-3.937
5"	0.276-2.244	1.890-4.921
6-1/4"	0.315-3.150	1.969-6.299
8"	0.591-5.118	2.480-7.874
10"	0.787-6.929	3.150-9.843
12-1/2"	0.984-9.843	3.937-12.40
15-3/4"	1.378-11.81	4.646-15.75
20"	1.969-15.75	4.921-19.69
25"	2.756-21.26	6.299-24.80
32"	3.937-26.77	7.874-31.50
40" *	4.921-32.28	9.874-39.37
50" *	6.299-37.80	11.81-49.21

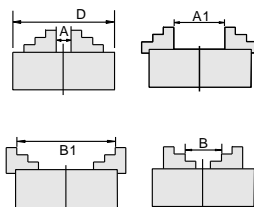

Spindle Nose	Chuck Diameter						
	6-1/4"	8"	10"	12-1/2"	15-3/4"	25" & 20"	32"
<b>A1/A2 Mount</b>							
A5	FLI-160A5	FLI-200A5					
A6		FLI-200A6	FLI-250A6	FLI-315A6	FLI-400A6	FLI-500A8	
A8				FLI-315A8	FLI-400A8	FLI-500A11	
A11					FLI-400A11		
A15							FLI-800A15
<b>D1 Mount - CAMLOCK</b>							
D4	FLI-160D4	FLI-200D4					
D6		FLI-200D6	FLI-250D6		FLI-400D6		
D8			FLI-250D8	FLI-315D8		FLI-500/D8	
D11				FLI-315D11	FLI-400/D11	FLI-500/D11	
<b>L Mount - Long Taper</b>							
L2							FLI-800L2
L3							FLI-800L3

### SPARE PARTS

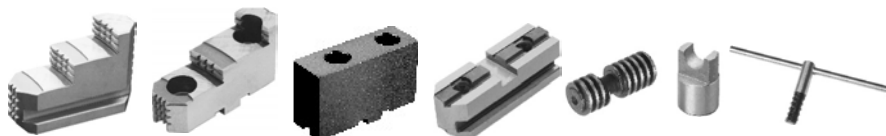

Chuck Dia. (D)	Hard Solid Reversible Jaw 1 set	Hard Top Jaw 1 set	Soft Top Jaw 1pc	Hard Master Jaw 1 set	Operating Screw 1pc	Thrust Bearing 1pc	Wrench 1pc
3-1/4"	RJ-PI-080	-	-	-	OS-PI-080	TB-PI-080	W-PI-080
4"	RJ-PI-100	-	-	-	OS-PI-100	TB-PI-100	W-PI-100
5"	RJ-PI-125	-	-	-	OS-PI-125	TB-PI-125	W-PI-125
6-1/4"	RJ-PI-160	-	-	-	OS-PI-160	TB-PI-160	W-PI-160
8"	RJ-PI-200	TJ-PI-200	STJ-PS1-200	MJ-PI-200	OS-PI-200	TB-PI-200	W-PI-250
10"	RJ-PI-250	TJ-PI-250	STJ-PS1-250	MJ-PI-250	OS-PI-250	TB-PI-250	W-PI-250
12-1/2"	RJ-PI-315	TJ-PI-315	STJ-PS1-315	MJ-PI-315	OS-PI-315	TB-PI-315	W-PI-400
15-3/4"	RJ-PI-400	TJ-PI-400	STJ-PS1-400	MJ-PI-400	OS-PI-400	TB-PI-400	W-PI-400
20"	RJ-PI-500	TJ-PI-500	STJ-PS1-500	MJ-PI-500	OS-PI-500	TB-PI-500	W-PI-630
25"	RJ-PI-630	TJ-PI-630	STJ-PS1-630	MJ-PI-630	OS-PI-630	TB-PI-630	W-PI-630
32"	RJ-PI-800	TJ-PI-800	STJ-PS1-630	MJ-PI-800	OS-PI-800	TB-PI-800	W-PI-800
40"	RJ-PI-1000	TJ-PI-1000	-	MJ-PI-1000	OS-PI-1000	TB-PI-1000	W-PI-1000
50"	RJ-PI-1250	TJ-PI-1250	-	MJ-PI-1250	OS-PI-1250	TB-PI-1250	W-PI-1250

# OIL COUNTRY CHUCKS, PEI Series

4 Jaw Independent Oil Country Chucks with Large Thru Hole  
Forged Steel Body, Extra Heavy Duty with A2 Mounts



## FEATURES

- Solid forged steel body
- ANSI - American Standard tongue and groove jaws
- All critical chuck surfaces are precision ground
- A2 mounts
- Large thru-hole
- Extra heavy duty master and top jaws
- Top and master jaws are provided with heavy duty serration
- Extra heavy duty operating screws and thrust bearings
- Superior gripping power
- Induction hardened guide ways and thru-hole
- High accuracy



Chuck Dia. A	Spindle Nose Mount	RPM	Weight lbs	Top Jaw Mounting Bolts	Operating Screw Thread Size	Clamping Capacity Min.-Max.
20"	A2-11	1000	450	3/4"-10	Tr44x8 LH	1.77-19.68
	A2-15	1000	414	3/4"-10	Tr44x8 LH	1.77-19.68
25"	A2-15	850	682	7/8"-9	Tr50x8 LH	1.97-24.80
	A2-20	850	649	7/8"-9	Tr50x8 LH	3.94-24.80
28"	A2-15	750	913	7/8"-9	Tr50x8 LH	2.95-27.95
	A2-20	750	869	7/8"-9	Tr50x8 LH	3.94-24.80
32"	A2-15	600	1287	7/8"-9	Tr50x8 LH	5.12-31.50
	A2-20	600	1243	7/8"-9	Tr50x8 LH	7.09-31.50
40"	A2-28	430	1683	7/8"-9	Tr50x8 LH	13.73-39.40

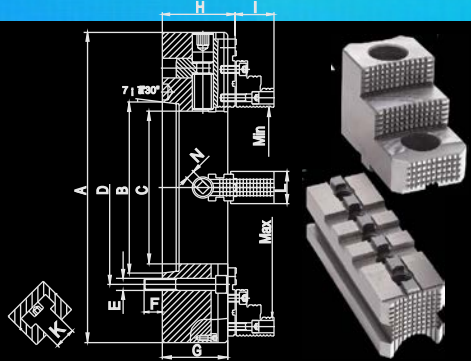

## Chuck Dimensions

Chuck Dia. A	Spindle Nose Mount	Thru Hole C	B	D	G	H	I	K	L	N	E	F	Part Number
20"	A2-11	6.5	7.75075	9.2500	5.71	6.067	2.981	.886	2.362	.748	M20X2.5	1.118	1-317-2011
20"	A2-15	8.0	11.251	13.000	5.71	6.067	2.981	.886	2.362	.748	M24X3	1.34	1-317-2015
25"	A2-15	10.5	11.251	13.000	6.10	6.579	3.571	.886	2.953	.866	M24X3	1.34	1-317-2515
	A2-20	12.55	16.251	18.252	6.10	6.579	3.571	.886	2.953	.866	M24X3	1.5	1-317-2520
28"	A2-15	10.5	11.251	13.000	6.10	6.579	3.571	.886	2.953	.866	M24X3	1.34	1-317-2815
28"	A2-20	12.55	16.251	18.252	6.10	6.579	3.571	.886	2.953	.866	M24X3	1.5	1-317-2820
32"	A2-15	10.5	11.251	13.000	6.50	6.972	3.571	.886	2.953	.866	M24X3	1.34	1-317-3215
32"	A2-20	12.55	16.251	18.252	6.50	6.972	3.571	.886	2.953	.866	M24X3	1.5	1-317-3220
40"	A2-28	20.86	23.001	25.500	6.89	7.366	3.571	1.10	2.953	.866	M24X3	1.53	1-317-4028

## Spare Parts.

Chuck Dia. A	Spindle Nose Mount	Hard Top Reverse Jaws 1pc.	Hard Master Jaws 1pc.	Thrust Bearing 1 pc.	Heavy Duty Wrench 1 pc.	Operating Screw 1 pc.
20"	A2-11	TJ-PEI-500	MJ-PEI-500	TB-PEI-500	W-PEI-500	OS-PEI-511
20"	A2-15	TJ-PEI-500	MJ-PEI-500	TB-PEI-500	W-PEI-500	OS-PEI-515
25"	A2-15	TJ-PEI-800	MJ-PEI-800	TB-PEI-630	W-PEI-1000	OS-PEI-631
25"	A2-20	TJ-PEI-800	MJ-PEI-800	TB-PEI-630	W-PEI-1000	OS-PEI-632
28"	A2-15	TJ-PEI-800	MJ-PEI-800	TB-PEI-630	W-PEI-1000	OS-PEI-715
28"	A2-20	TJ-PEI-800	MJ-PEI-800	TB-PEI-630	W-PEI-1000	OS-PEI-720
32"	A2-15	TJ-PEI-800	MJ-PEI-800	TB-PEI-1000	W-PEI-1000	OS-PEI-815
32"	A2-20	TJ-PEI-800	MJ-PEI-800	TB-PEI-1000	W-PEI-1000	OS-PEI-820
40"	A2-28	TJ-PEI-1000	MJ-PEI-1000	TB-PEI-1000	W-PEI-1000	OS-PEI-928

# OIL COUNTRY CHUCKS, PEO Series

## 3 Jaw Self-Centering Chucks

Large Thru Hole  
Forged Steel Body,  
Extra Heavy Duty  
A2 Mount



- Extra Heavy Duty
- ANSI-American Standard Tongue and Groove Jaws
- Master and Top Jaws are provided with Heavy Duty Serration
- All chucks provided with A2 mounts
- Extra large thru hole
- Extra wide master jaws
- Forged Steel Body

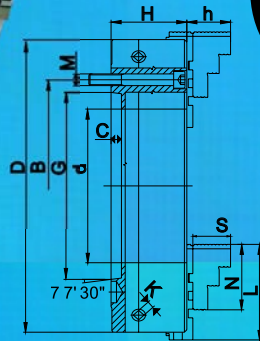

## Chuck Parameters

Chuck Dia. A	Spindle Nose Size	Thru Hole d	B	G	H	h	C	S	N	K	L	Max. Speed RPM	Weight lbs	Part Number
20"	A2-11	7.48	9.25	7.75075	4.685	3.425	.7500	2.980	5.315	.748	6.5354	1000	560	1-119-2011
20"	A2-15	8.00	13.00	11.251	4.685	3.425	.8125	2.980	5.315	.748	6.5354	1000	530	1-119-2015
25"	A2-15	10.75	13.00	11.251	6.063	3.642	.8125	3.295	5.315	.866	8.858	850	650	1-119-2515
25"	A2-20	12.55	18.25	16.251	6.063	3.642	.8750	3.295	5.315	.866	8.858	850	620	1-119-2520
32-1/2"	A2-15	10.75	13.00	11.251	6.300	3.642	.8125	3.295	5.315	.866	8.858	600	1200	1-119-3215
32-1/2"	A2-20	12.55	18.25	16.251	6.300	3.642	.9450	3.295	5.315	.866	8.858	600	1170	1-119-3220

Chuck Dia. A	Spindle Nose Size	Hard Top Jaw Width	Hard Master Jaw Width	Weight lbs	Spindle Mounting Bolts	Top Jaw Mounting Bolts	Load Capacity lbs.	Clamping Capacity Min.-Max.	Gripping Force lbf
20"	A2-11	2.362	2.362	560	M20x2.5	3/4"-10	5.200	1.77-19.68	16300
20"	A2-15	2.362	2.362	530	M24X3	3/4"-10	5.200	1.77-19.68	16300
25"	A2-15	3.543	3.150	650	M24X3	7/8"-9	7.800	3.15-24.8	18040
25"	A2-20	3.543	3.150	620	M24X3	7/8"-9	7.800	6.30-24.80	18040
32-1/2"	A2-15	3.543	3.150	1200	M24X3	7/8"-9	10.400	5.12-31.50	19140
32-1/2"	A2-20	3.543	3.150	1150	M24X3	7/8"-9	10.400	7.09-31.50	19140



## Spare Parts.

Chuck Size	Hard Top Jaws 1 set.	Hard Master Jaws 1 set.	Pinion 1 pc.	Scroll Plate 1 pc.	Pinion Half Ring 1 pc.	Wrench 1 pc.
20"	TJ-PEO-500	MJ-PEO-500	PI-PEO-500	SC-PEO-500	HR-PEO-500	W-PEI-500
25"	TJ-PEO-800	MJ-PEO-500	PI-PEO-630	SC-PEO-630	HR-PEO-630	W-PEI-1000
32"	TJ-PEO-800	MJ-PEO-800	PI-PEO-800	SC-PEO-800	HR-PEO-800	W-PEI-1000

**gator chucks**<sup>™</sup>  
BY FUERDA

# EA Series Adjustable Chucks

3 Jaw & 6 Jaw Self-Centering  
Semi-Steel body  
Plain Back  
With Fine Adjustment, 0.0005" T.I.R.

EA Series Semi-Steel Adjustable Scroll Chucks can be used for all machining operations where universal chucks are used, along with applications where universal scroll chucks are unsuitable.

**Each chuck is provided with:**

- 1 set of hard master jaws
- 1 set of hard top reversible jaws
- 1 chuck wrench
- 1 set of mounting screws
- 2 hex key
- semi-steel body
- 1 pinion design



- Two-piece American standard Reversible Jaws, Plain Back, Semi-steel Body. American Standard popular adjustable scroll chucks.
- 2-Piece Body Design
- 10", 12" & 15" chucks are provided with the pinion fitted in the steel bushing

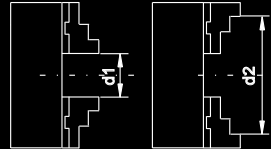

■ **Min. - Max. Clamping Capacity**

**3-Jaw Chuck**

Chuck dia.	5"	6"	8"	10"	12"	15"
d1 min-max	.1181-1.969	.1181-2.519	.1575-3.543	.1969-4.646	.3937-5.157	.3937-7.087
d2 min-max	2.953-4.646	3.425-5.748	4.331-7.480	5.394-9.764	6.496-10.433	7.441-12.953

**6-Jaw Chuck**

Chuck dia.	5"	6"	8"	10"	12"	15"
d1 min-max	.2362-1.693	.3150-2.520	.3150-3.543	.5118-4.646	.5118-5.157	.630-7.953
d2 min-max	2.992-4.685	3.622-5.748	4.528-7.677	5.709-10.079	6.693-11.024	7.677-14.961

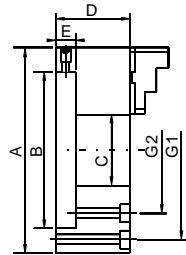

■ **Chuck Dimensions**

Chuck Size	A	B	C	D	E	G1	G2	Qty of bolts	G1, G2 Thread	3 Jaw			6 Jaw		
										Model	Part No.	RPM max.	Model	Part No.	RPM max.
5"	5.0	2.375	1.230	2.20	0.66	4.44	-	3	1/4"-20	EA3-5"A	1-901-0500	3200	EA6-5"A	1-903-0500	2700
6"	6.0	3.125	1.540	2.35	0.69	5.34	-	6	1/4"-20	EA3-6"A	1-901-0600	3000	EA6-6"A	1-903-0600	2500
8"	8.25	4.750	2.346	3.15	0.75	7.50	-	6	3/8"-16	EA3-8"A	1-901-0800	2500	EA6-8"A	1-903-0800	2000
10"	10.0	6.375	2.860	3.40	0.81	-	4.38	6	7/16"-14	EA3-10"A	1-901-1000	2000	EA6-10"A	1-903-1000	1600
12"	12.0	7.906	3.285	4.00	0.84	-	5.25	6	1/2"-13	EA3-12"A	1-901-1200	1500	EA6-12"A	1-903-1200	1100
15"	15.0	11.781	4.250	5.78	1.13	-	6.75	6	5/8"-11	EA3-15"A	1-901-1500	1000	EA6-15"A	1-903-1500	700

## FLE Series Semi-Steel Adapter, Fully Machined for EA Series Chucks

\*Note: All these adapters do not require any additional machining.



Type A



Type D



Type L



Type T

Chuck Dia.	Taper No.	Type (A1, A2) Part No.	Type D (Part No.)	Taper No.	Type L (Part No.)	Thread Size	Type T (Part No.)
5"	3	--	FLE-125/D3	-	-	-	-
5"	4	--	FLE-125/D4	-	-	-	-
6"	3	--	FLE-160/D3	-	-	1-1/2"-8UN-2B	FLE-160T2
6"	4	--	FLE-160/D4	L00	FLE-160/L00	2-3/16"-10 Hardinge	FLE-160T4
6"	5	FLE-160/A5	FLE-160/D5	L0	FLE-160/L0	2-1/4"-8UN-2B	FLE-160T5
8"	4	FLE-200/A4	FLE-200/D4	L00	FLE-200/L00	1-1/2"-8UN-2B	FLE-200T2
8"	5	FLE-200/A5	FLE-200/D5	L0	FLE-200/L0	2-1/4"-8UN-2B	FLE-200T5
8"	6	FLE-200/A6	FLE-200/D6	L1	FLE-200/L1	2-3/8"-6UN-2B	FLE-200T6
10"	5	FLE-250/A5	FLE-250/D5	L00	FLE-250/L00	2-1/4"-8UN-2B	FLE-250T5
10"	6	FLE-250/A6	FLE-250/D6	L0	FLE-250/L0	2-3/8"-6UN-2B	FLE-250T6
10"	8	FLE-250/A8	FLE-250/D8	L1	FLE-250/L1	-	-
12"	6	FLE-315/A6	FLE-315/D6	L0	FLE-315/L0	-	-
12"	8	FLE-315/A8	FLE-315/D8	L1	FLE-315/L1	-	-
12"	11	FLE-315/A11	FLE-315/D11	L2	FLE-315/L2	-	-
15"	6	FLE-400/A6	FLE-400/D6	L1	FLE-400/L1	-	-
15"	8	FLE-400/A8	FLE-400/D8	L2	FLE-400/L2	-	-
15"	11	FLE-400/A11	FLE-400/D11	L3	FLE-400/L3	-	-



■ Sold in set.



■ Sold in set.

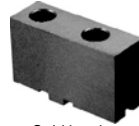

■ Sold by piece.

Part No.	Hard Top Jaws		Hard Master Jaws		Soft Top Jaws	
	3-Jaw	6-Jaw	3-Jaw	6-Jaw	3-Jaw	6-Jaw
5"	TJ-PS3-125	TJ-PS6-125	MJ-PS3-125	MJ-PS6-125	STJ-PS1-125	STJ-PS6-125
6"	TJ-PS3-160	TJ-PS6-160	MJ-PS3-160	MJ-PS6-160	STJ-PS1-160	STJ-PS6-160
8"	TJ-PS3-200	TJ-PS6-200	MJ-PS3-200	MJ-PS6-200	STJ-PS1-200	STJ-PS6-200
10"	TJ-PS3-250	TJ-PS6-250	MJ-PS3-250	MJ-PS6-250	STJ-PS1-250	STJ-PS6-250
12"	TJ-PS3-315	TJ-PS6-315	MJ-PS3-315	MJ-PS6-315	STJ-PS1-315	STJ-PS6-315
15"	TJ-PS3-400	TJ-PS6-400	MJ-PS3-400	MJ-PS6-400	STJ-PS1-400	STJ-PS6-400

■ Dimension please see page 25-26.



Part Number	Scroll 1pc	Pinion 1pc	Wrench* 1pc	Pinion Screw 1pc	Pinion Sleeve 1pc	Half Ring 1pc	Fine Adjustment Screws 1pc	QTY
5"	SC-PS125	PI-E-125	W-P-125	PH-E-125	-	-	FS-E-125	4
6"	SC-PS-160	PI-E-160	W-P-200	PH-E-160	-	-	FS-E-160	4
8"	SC-PS-200	PI-E-200	W-P-200	PH-E-200	-	-	FS-E-200	4
10"	SC-PS-250	PI-E-250	W-P-315	-	PS-E-250	HR-E-250	FS-E-250	4
12"	SC-PS-315	PI-E-315	W-P-315	-	PS-E-315	HR-E-315	FS-E-315	4
15"	SC-PS-400	PI-E-400	W-P-400	-	PS-E-400	HR-E-400	FS-E-400	8

\*W-SP- Extended Wrenches available from stock.