

AHB

TOOLING & MACHINERY

COMPLETE METALWORKING SOLUTIONS

(800) 991-4225

www.ahbinc.com

ISO Certified

customerservice@ahbinc.com

LYNDEX NIKKEN



LYNDEX
NIKKEN
1448 Avenue Boulevard
Mundelein, IL 60060
(847) 357-4000



L N



LYNDEX-NIKKEN

Company Profile



ENGINEERED SOLUTIONS

AEROSPACE & DEFENSE

Patriotism Through Innovation

Lyndex-Nikken expertly engineered Toolholders satisfy the manufacturing demands of global aviation. No matter the aerospace component you make, Lyndex-Nikken can help you make it better, faster, and more productively. We provide the high performance tools that leading aerospace manufacturers require to compete effectively when manufacturing engines, airframes, landing gear, and instrumentation.

CONSTRUCTION

Paving with Technology

The construction industry exceeds the traditional demands for machining. Lyndex-Nikken's experience working with equipment manufacturers from around the world involving large casting machining, forging, hydraulic components, gears, and drive transmission components. We help boost manufacturing processes and minimize scrap.

POWER & ENERGY

Powering to Perfection

You can rely on Lyndex-Nikken's tooling capabilities like your customers rely on your support for power. From power generation to power distribution, we work to improve the efficiency in the parts manufactured to help deliver your dependable services. With machine tools and accessories featuring powerful clamping systems, precise positioning, and big bore through-holes, we supply expert solutions for the critical demands of the energy production industry.



Visit us online at www.lyndexnikken.com



Phone: (847) 367-4800

FOR EVERY INDUSTRY...

MEDICAL

Bringing Accuracy to Life

Accuracy and repeatability are most critical when it comes to manufacturing medical parts. Industry developments and advanced research have made parts smaller, but these developments also have increased the complexity and the accuracy requirements for micro-precision manufacturing. Let the leader in micro precision tooling systems become a part of your medical repertoire.

AUTOMOTIVE

Driven by Quality

Automotive engineering is more than designing a beautiful car or winning a race; it's about being able to perform both expertly and consistently. Because we understand that your brand's recognition starts with consistency in manufacturing, we have developed tooling systems with the highest degree of precision and rigidity to assure the most reliable manufacturing.

DIE & MOLD

Never Leave a Witness

We understand that you don't have the luxury of time to make mistakes. With finish callout as critical as the part dimensions themselves, we present our pre-balanced high speed tooling for your high-RPM machining needs.



Download catalogs for all of our products by visiting
www.lyndexnikken.com/Online-Catalogs



Pictured: CNC1600



Visit us online at www.lyndexnikken.com



Phone: (847) 367-4800

4TH AXIS ROTARY TABLES

Reduced Setups, Increased Productivity, More Profits

- Ion-Nitride Worm Wheel and Carbide Worm Screw design extends longevity of rigidity and accuracy.
- 4 arc second repeatability for high precision and complex work pieces.
- Full installation and integration services available by Lyndex-Nikken technicians.

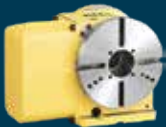

CNC202



CNC302

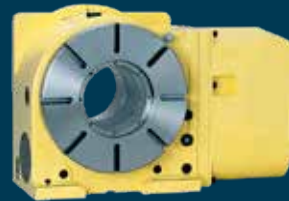

CNCB350



CNC401

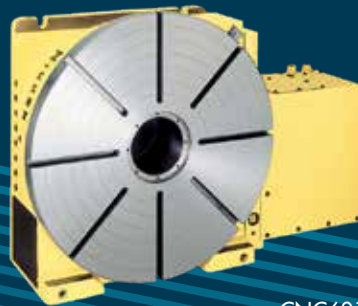

CNC601



Download catalogs for all of our products by visiting
www.lyndexnikken.com/Online-Catalogs



Pictured: 5AX-1200



Visit us online at www.lyndexnikken.com



Phone: (847) 367-4800

5TH AXIS ROTARY TABLES

Reduced Setups, Increased Productivity, More Profits

- High tilt axis brake clamping force allows for aggressive milling at 90°.
- Compact design provides a large 5-axis work envelope for 30-taper machines.
- Lower profile trunnion design optimizes rigidity at all tilt angles.
- 5-axis rotary tables available from 6" to 48".



5AX-130



5AX-201



5AX-350

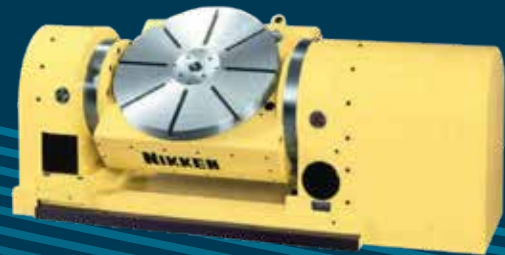

5AX-550



Download catalogs for all of our products by visiting
www.lyndexnikken.com/Online-Catalogs



LIVE & STATIC TOOLS

Turning Your Lathe Into a Milling Machine

- We offer both Live and Static Tools for a multitude of machine builders.
- Dual radial and thrust bearing design for added rigidity.
- Live and Static tools offered in coolant through, adjustable, and multi-output.



*Download catalogs for all of our products by visiting
www.lyndexnikken.com/Online-Catalogs*

POWER CHUCKS

QUICK CHANGE COLLET CHUCKS



CUSTOM DESIGN POWER CHUCKS



HOWA POWER CHUCKS

Workholding Solutions for Turning Centers

- Wide variety of Power Chucks for all turning centers.
- Engineered workholding solutions for high production projects.
- Quick Change Collet Chucks allow for fast set-up between jobs.
- Quick Change Collets come in a wide variety of shapes and sizes offered in smooth, serrated, and hexagon.



*Download catalogs for all of our products by visiting
www.lyndexnikken.com/Online-Catalogs*

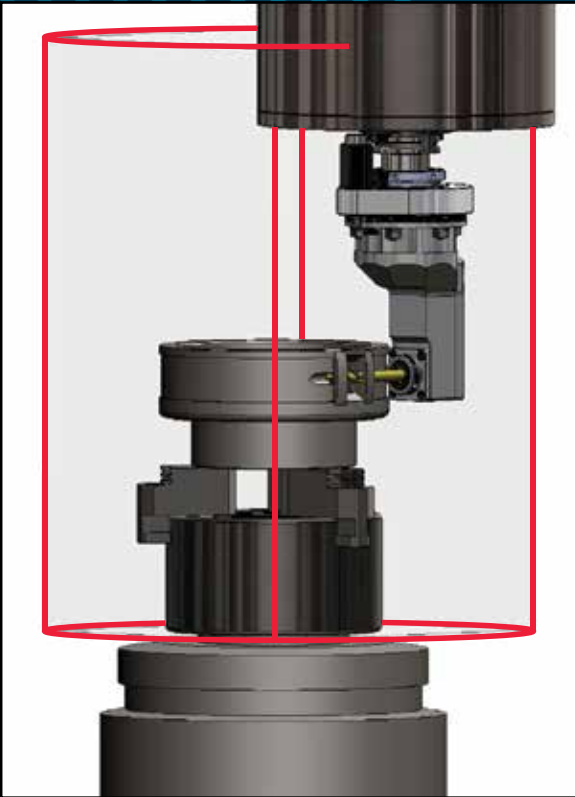

MODULAR & FIXED ANGLE HEADS

Approaching Difficult Parts from All Angles

- Offered in multiple styles: slim, rigid, offset, adjustable and coolant through.
- 452 possible combinations using Lyndex-Nikken's Modular Angle Head system.
- Clearance and ATC verification done by 3D printed Angle Heads.
- Full 3D model support upon request.



*Download catalogs for all of our products by visiting
www.lyndexnikken.com/Online-Catalogs*

FI-6 UNIT



START.2 UNIT



Visit us online at www.lyndexnikken.com



Phone: (847) 367-4800

SHRINK FIT SYSTEM

Advanced Technology for Precision Machining

- Fastest shrinking time ranging from 2-7 seconds.
- Widest range available for a desktop unit 2-40mm (0.078" to 1.575").
- Can shrink any Cutting Tool material from high speed steel to solid carbide.
- Special Shrink Fit machine and Toolholder package available.**

***Contact Lyndex-Nikken for details.*



*Download catalogs for all of our products by visiting
www.lyndexnikken.com/Online-Catalogs*



HIGH PRODUCTIVITY ADVANCED TOOLHOLDERS

Covering All Bases for Your Toolholder Needs

- Most accurate and precise Collet Chucks in the industry (guaranteed runout within .0002").
- Nikken Milling Chucks are the strongest clamping Toolholder in the world with over 3500 ft. lbs of gripping force.
- Greater rigidity and higher accuracy allows for more aggressive material removal and part precision.



*Download catalogs for all of our products by visiting
www.lyndexnikken.com/Online-Catalogs*



HYDRAULIC HOLDERS

Hydraulic Clamping for Dampening Capability

- Advanced design allows for greatest surface area contact between Toolholder and Cutting Tool.
- Offered in a variety of body styles and lengths.
- 3-4 times clamping power compared to traditional ER Collet Chucks.



*Download catalogs for all of our products by visiting
www.lyndexnikken.com/Online-Catalogs*



Visit us online at www.lyndexnikken.com



Phone: (847) 367-4800

TAPER PLUS TOOLHOLDERS

Taking Rigidity to the Next Level

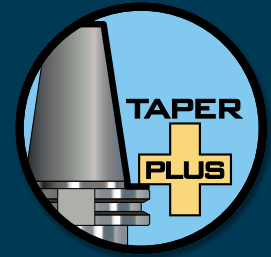

- Dual Taper and Flange Contact Holders available for both Standard and Advanced Holders.
- Added surface area contact provides 30-40% more rigidity allowing for more aggressive machining.
- Flange contact provides greater support for long length Toolholder applications on horizontal machining centers.



*Download catalogs for all of our products by visiting
www.lyndexnikken.com/Online-Catalogs*

E460N



E46 SERIES



E68 SERIES

More Presetter models are available. Contact us for details.



Visit us online at www.lyndexnikken.com



Phone: (847) 367-4800

ELBO CONTROLLI - NIKKEN PRESETTERS

Thermal Stability Coupled with High Precision

- Precision ground granite is used for the base and column, providing the utmost thermal stability for high repeatability and reproducibility during tool measuring and inspecting applications.
- Interchangeable spindles eliminate the need for adapters which can introduce additional errors.
- All units come with fifty of the most common post processors for today's CNC controls.



*Download catalogs for all of our products by visiting
www.lyndexnikken.com/Online-Catalogs*



Visit us online at www.lyndexnikken.com



Phone: (847) 367-4800

PRECISION STANDARD TOOLHOLDERS

Covering All Bases for Your Toolholder Needs

- Widest range from Standard End Mill Holders and ER Collet Chucks to high performance Milling Chucks and SK Precision Collet Chucks.
- Lyndex-Nikken provides the best tools that balance budget and performance.
- Stocked and distributed from Illinois for fast delivery.



*Download catalogs for all of our products by visiting
www.lyndexnikken.com/Online-Catalogs*



MACHINE TOOL ACCESSORIES

Offerings from Precision to Production

- Heat treated and ground, Lyndex-Nikken's precision Collets provide the most accuracy and reliability.
- Collets available in many shapes and sizes for bar feeding or precision turning applications.
- Wide offering of accessories ranging from Test Bars, Height Gauges, and Retention Knobs.



*Download catalogs for all of our products by visiting
www.lyndexnikken.com/Online-Catalogs*

MISSION STATEMENT FROM OUR PRESIDENT



Hiro Kashiwakura, President

"Our mission is to provide the best value in machine tool accessories to help our customers become more profitable and promote manufacturing in North America. To Lyndex-Nikken, value means manufacturing quality products at a fair price.

We have built the widest product offering in the industry. As part of our mission, we also make it easy for manufacturers to fill their accessory needs while always focusing on return-on-investment. We achieve this by finding the best people and a fundamental principle of continuous improvement.

In this ever-changing market, our passion is to offer solutions to customer needs versus products. We pledge our unwavering stand on quality over price."

LYNDEX-NIKKEN TIMELINE

 <p>January 5th, 1979 Lyndex Corporation was founded, selling 5C Collets.</p>	 <p>February, 1989 Angle Head products were introduced.</p>	 <p>June, 2001 HQ relocated to 50,000 ft² building in Mundelein, IL.</p>	 <p>February, 2003 Product line expanded to include 4th and 5th Axis Rotary Tables.</p>
 <p>April, 1981 Added Toolholders to our product line.</p>	 <p>August, 1998 Product line expanded to include Live Tools.</p>	 <p>June, 2002 Acquired by Nikken Kosakusho Works, Ltd.</p>	



Visit us online at www.lyndexnikken.com



Phone: (847) 367-4800

HISTORY OF LYNDEX-NIKKEN

Lyndex Corporation

Founded in 1979 in Glenview, Illinois, Lyndex Corporation set the standard for quality toolholding in the United States as a supplier of 5C and R8 Collets. Over the years, Lyndex's product line evolved to include a vast selection of toolholding and accessories. With a commitment to quality products and excellent customer service, Lyndex garnered industry-wide respect as a trusted source for toolholding and metalworking accessories.

Nikken Japan

Nikken Kosakusho Works, Ltd. was established in Japan in 1958 by founder, Masakazu Matsumoto and has a rock solid reputation there as the top manufacturer of Toolholders and machine tool accessories. Nikken has been a market leader in various industries such as aerospace, automotive and ultra-precision machining since the company's inception.

In Japanese, the name Nikken stands for "research every day". Nikken is committed to technological advancement and customer satisfaction. Annually, they produce 350,000 Toolholders, 3,000 CNC Rotary Tables, and 250,000 Reamers. A global company, Nikken's sales and technical service network consists of over 700 employees worldwide.

Lyndex-Nikken

In 2002, Lyndex Corporation merged with Nikken Kosakusho Works, Ltd. From the merging of these two great companies, an even greater company came forth. Lyndex-Nikken, as a unified manufacturer, boasts a broader product line, a greater number of service personnel, and a higher degree of engineering support and technology. Together, Lyndex and Nikken represent the best of both sides of the manufacturing industry: extreme quality and advanced technology.



June, 2009

Introduction of Solution Partner Program.



February, 2014

Lyndex-Nikken University was built.



January, 2016

Started Robotics/Automation Group.



August, 2003

Began offering full installation and interface of Rotary Tables.



June, 2013

Expanded sales and service to Mexico and South America with office in Mexico.



September, 2014

Introduced Turning Accessories (Howa, QCFC).



March, 2017

Launched Customer Zone Website.



Download catalogs for all of our products by visiting www.lyndexnikken.com/Online-Catalogs

MANAGEMENT & OPERATIONS

Integrity is our highest company goal that is achieved in different ways in each department. In operations, this means "keeping promises". When a Lyndex-Nikken salesperson commits to do something, we want to make sure it happens! Our management team is willing to put whatever resources are needed to stand behind ALL commitments made to our customers.



OUTSIDE SALES

The outside sales team is committed to providing you with the highest level of training, product knowledge, and customer service. Whether it's helping you close more deals, increasing your profit margins, or making your job easier, our product managers and sales representatives will do what is needed to make you more successful!

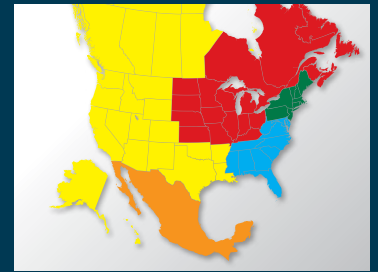

INSIDE SALES

Committed to upholding the highest standard in customer service, the inside sales team provides support to qualify, quote and process orders. Working in conjunction with our outside sales team, our goal is to provide the best expedited sales experience with the utmost clarity.



ENGINEERING & SERVICE

From product drawings to 3D models, clearance verifications to force calculations, the engineering team understands your manufacturing needs. We look forward to providing application support and hope to be a part of your success.

Knowing how important it is to minimize downtime, with over 40 years of combined experience servicing rotary tables and Toolholders, the service team is dedicated to maintaining the longevity, precision and reliability of Lyndex Nikken products.



MARKETING

The marketing team strives to promote the quality products and services we represent. Our goal is to continually discover and implement new methods that enhance your experience and engagement through social media, instructional videos, product catalogs, and much more.



ACCOUNTING

Our accounting team makes accuracy its first goal. Keeping well-organized records and providing top-notch reporting and information is key to our team. We aim to communicate well to our customers and our internal customers to facilitate sales. We believe we are all salespeople!



WAREHOUSE & SHIPPING

With over 22,000 individual part numbers in our system and nearly \$50 million worth of in-stock inventory, our warehouse team means serious business. 95% of items we carry get shipped out same day on an impressive average of 160 shipments per day!



LYNDEX-NIKKEN MEXICO

Since our opening in 2013, we have been able to extend the same level of quality support to Mexico. One of our biggest tasks is providing services for transplant companies in Mexico from the U.S., Germany, Japan, and Korea. We offer full service of sales, engineering, and application support directly from our office.



*Download catalogs for all of our products by visiting
www.lyndexnikken.com/Online-Catalogs*



1468 Armour Boulevard
Mundelein, IL 60060

Web: www.lyndexnikken.com
E-mail: sales@lyndexnikken.com
Phone: (847) 367-4800
Fax: (847) 367-4815

CAT2019-LINECARD

Follow us on social media!



@LyndexNikken



Lyndex-Nikken



Lyndex-Nikken



LyndexNikkenMedia



@Lyndex_Nikken