

High Precision Air Chucks

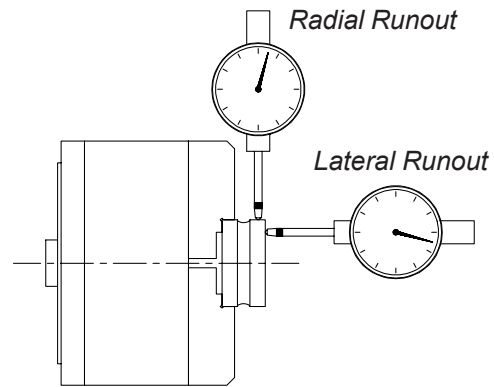

Improve productivity and lower the cost of secondary machining operations

through high concentricity. Holding close concentricity tolerances during each machining operation not only reduces scrap rates, but also allows you to leave less material for finishing operations. Therefore, you reduce cycle time and improve tool life of finishing operations. And MicroCentric air chucks give you the capability to improve workpiece roundness, squareness, and parallelism as well.



Over 30 years of advanced design and engineering

has made MicroCentric the world's leading builder of precision chucks. MicroCentric air chucks are a sliding jaw, self-contained design. Air is supplied to the chuck by a rotating air tube assembly, or directly in the side of the chuck body for stationary applications. Air chucks can be actuated by a manual or electronic solenoid valve. Clamping force is adjusted by varying the input air pressure.

MicroCentric air chucks are an open center design with separate actuators for each base jaw. They feature a meehanite chuck body with hardened steel actuators and base jaws. All components are precision ground, and the base jaws are lapped to fit with each individual jaw slot, assuring high repeating accuracy and minimal jaw lift as the chuck clamps. MicroCentric air chucks are double acting for both ID and OD applications.

Accuracy within .00005" TIR

A standard repeating accuracy of .00005" TIR means the radial and lateral runout of your workpieces will be held within .00005" (0.0012mm). Models with higher accuracy are also available.

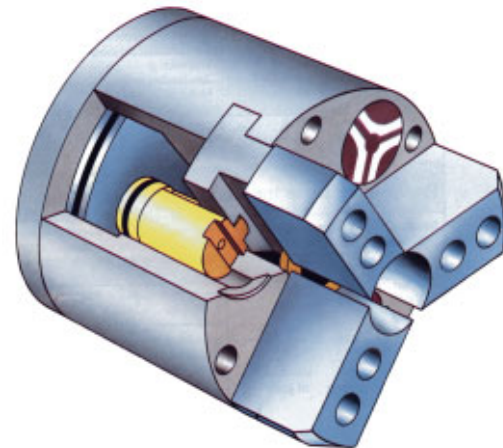

Rotating Air Chuck Design



Stationary Air Chuck Design

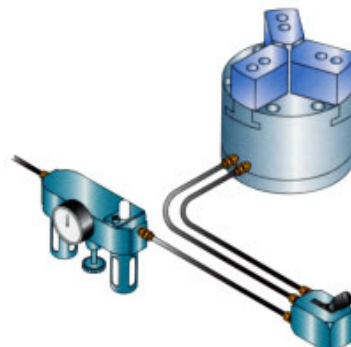

Air Chuck Models

Rotating Air Chucks



Rotating air chucks are ideal for precision turning and cylindrical grinding applications that call for close concentricity and squareness tolerances. Rotating air chucks are available in sizes from 3 to 10 inches in diameter, in 3 and 2 jaw configurations.

Stationary Air Chucks



Stationary air chucks are ideal for milling, drilling, tapping, welding, and other applications requiring a compact self-contained workholding fixture. Stationary air chucks are available in sizes from 3 to 10 inch diameter, in 3 and 2 jaw configurations.

Long Stroke Air Chucks



Long stroke air chucks feature extended jaw opening for load clearance or to clamp a range of diameters. Long stroke chucks are available in sizes from 4 to 10 inch diameters, in 3 and 2 jaw configurations, with jaw stroke up to 1.00" on diameter.

HST High Speed Air Chucks



MicroCentric HST series chucks feature a titanium chuck body for low mass and inertia. HST chucks are actuated by a patented external wedge design that maintains clamping force at spindle speeds up to 10,000 rpm without using counterweights. HST chucks are available in 3, 4, and 6 inch models.

Sealed Air Chucks

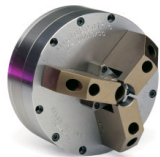

Sealed air chucks feature a stainless steel cover that completely seals the jaw slides. This design prevents contamination from grit and swarf and minimizes chuck maintenance for high volume production applications. Sealed chucks are available in sizes from 3 to 6 inch diameters.

Large Diameter Air Chucks



MicroCentric large diameter air chucks offer high accuracy and adjustable clamping force for machining large precision workpieces. Large diameter chucks are available in 12, 14, 16, and 20 inch diameters, in 3, 6, and 2 jaw configurations.

Rotating Air Chucks



Rotating air chucks are ideal for precision turning and cylindrical grinding applications that require close concentricity, squareness, and parallelism tolerances. Variable clamping force enables clamping of thin-walled and other fragile parts with minimal distortion. All models, except the 3-50, feature a coolant or air passage through the center of the chuck.

Chuck Accuracy

- .00005" (0.0012mm) TIR is standard
- .00002" (0.0005mm) TIR is available

Rotating Air Chuck Specifications

Chuck Size	Chuck Model	# of Jaws*	Chuck Accuracy**	Jaw Stroke***	Max. Clamp Force	Max. air Pressure	Max. rpm****	Chuck Weight
3 inch 80 mm	3-50-3	3	.00005"	.050"	304 lb/jaw	100 psi	6,000	3 lb
	3-50C-3	3	.0012 mm	1.3 mm	138 kg/jaw	7.0 kg/cm ²	6,000	1.4 kg
4 inch 100 mm	4-40-3	3	.00005"	.050"	304 lb/jaw	100 psi	6,000	3 lb
	4-120-3	3	.0012 mm	1.3 mm	138 kg/jaw	7.0 kg/cm ²	6,000	1.4 kg
6 inch 150 mm	6-40-3	3	.00005"	.040"	568 lb/jaw	100 psi	6,000	6 lb
	6-120-3	3	.0012 mm	1.0 mm	258 kg/jaw	7.0 kg/cm ²	6,000	2.7 kg
8 inch 200 mm	8-120-3	3	.00005"	.120"	568 lb/jaw	100 psi	4,000	7 lb
	6-120-3	3	.0012 mm	3.0 mm	258 kg/jaw	7.0 kg/cm ²	4,000	3.2 kg
10 inch 250 mm	8-120-3	3	.00005"	.040"	867 lb/jaw	100 psi	4,000	14 lb
	10-220-3	3	.0012 mm	1.0 mm	394 kg/jaw	7.0 kg/cm ²	4,000	6.4 kg
10 inch 250 mm	8-120-3	3	.00005"	.120"	867 lb/jaw	100 psi	4,000	16 lb
	10-220-3	3	.0012 mm	3.0 mm	394 kg/jaw	7.0 kg/cm ²	4,000	7.3 kg
10 inch 250 mm	8-120-3	3	.00005"	.120"	1,628 lb/jaw	100 psi	3,500	42 lb
	10-220-3	3	.0012 mm	3.0 mm	740 kg/jaw	7.0 kg/cm ²	3,500	19 kg
10 inch 250 mm	10-220-3	3	.00005"	.220"	2,548 lb/jaw	100 psi	3,000	77 lb
	10-220-3	3	.0012 mm	5.6 mm	1,158 kg/jaw	7.0 kg/cm ²	3,000	35 kg

*2 jaw configurations available for all air chuck sizes, 6 jaw configurations available on 10 inch (250 mm) models
 **Chuck accuracy is defined as the total indicator reading (maximum radial and lateral runout) of a master gage measured 1.0" (25 mm) from the face of a standard top jaw
 ***Total jaw stroke (on diameter)
 ****Max. rpm is influenced by air pressure and mass of top jaws

Available Options (see pages 15 to 16)

- QC (QC Jaw System) - Precision located top jaw system
- UP (Ultra Precision) - Chucking accuracy within .00002" (0.0005mm)
- AL (Auto-Lube) - Lubrication passage through center of air tube
- BP (Back Ported) - Through hole design with air ports in back of chuck

Rotating Air Chuck Dimensions

Model		A	B	C	D	E	F	G	H	J	K	L	M	N
3-50-3	inch	3.175	2.000	0.749	n/a	1.535	0.060	0.249	0.203	0.354	0.300	2.750	0.125	M5
	mm	80.6	50.8	19.0	n/a	39.0	1.5	6.3	5.2	9.0	7.6	69.9	3.2	M5
3-50C-3	inch	3.175	2.000	0.749	n/a	1.535	0.060	0.354	0.203	0.354	0.300	2.750	0.125	M5
	mm	80.6	50.8	19.0	n/a	39.0	1.5	9.0	5.2	9.0	7.6	69.9	3.2	M5
4-40-3	inch	3.950	3.249	0.749	0.752	2.060	0.060	0.255	0.203	0.354	0.680	3.500	0.125	M5
	mm	100.3	82.5	19.0	19.1	52.3	1.5	6.5	5.2	9.0	17.3	88.9	3.2	M5
4-120-3	inch	3.950	3.249	0.749	0.752	2.460	0.060	0.249	0.203	0.354	0.860	3.500	0.125	M5
	mm	100.3	82.5	19.0	19.1	62.5	1.5	6.3	5.2	9.0	21.8	88.9	3.2	M5
6-40-3	inch	5.950	4.920	0.749	1.000	2.060	0.120	0.255	0.265	0.430	0.680	5.350	0.125	M5
	mm	151.1	125.0	19.0	25.4	52.3	3.0	6.5	6.7	10.9	17.3	135.9	3.2	M5
6-120-3	inch	5.950	4.920	0.749	1.000	2.460	0.120	0.249	0.265	0.430	0.860	5.350	0.125	M5
	mm	151.1	125.0	19.0	25.4	62.5	3.0	6.3	6.7	10.9	21.8	135.9	3.2	M5
8-120-3	inch	8.000	6.600	1.188	1.010	3.428	0.135	0.620	0.421	0.656	0.500	7.200	0.250	M10
	mm	203.2	167.6	30.2	25.7	87.1	3.4	15.7	10.7	16.7	12.7	182.9	6.4	M10
10-220-3	inch	10.000	8.500	1.188	1.193	4.000	0.190	0.561	0.421	0.656	1.520	9.200	0.250	M10
	mm	254.0	215.9	30.2	30.3	101.6	4.8	14.2	10.7	16.7	38.6	233.7	6.4	M10

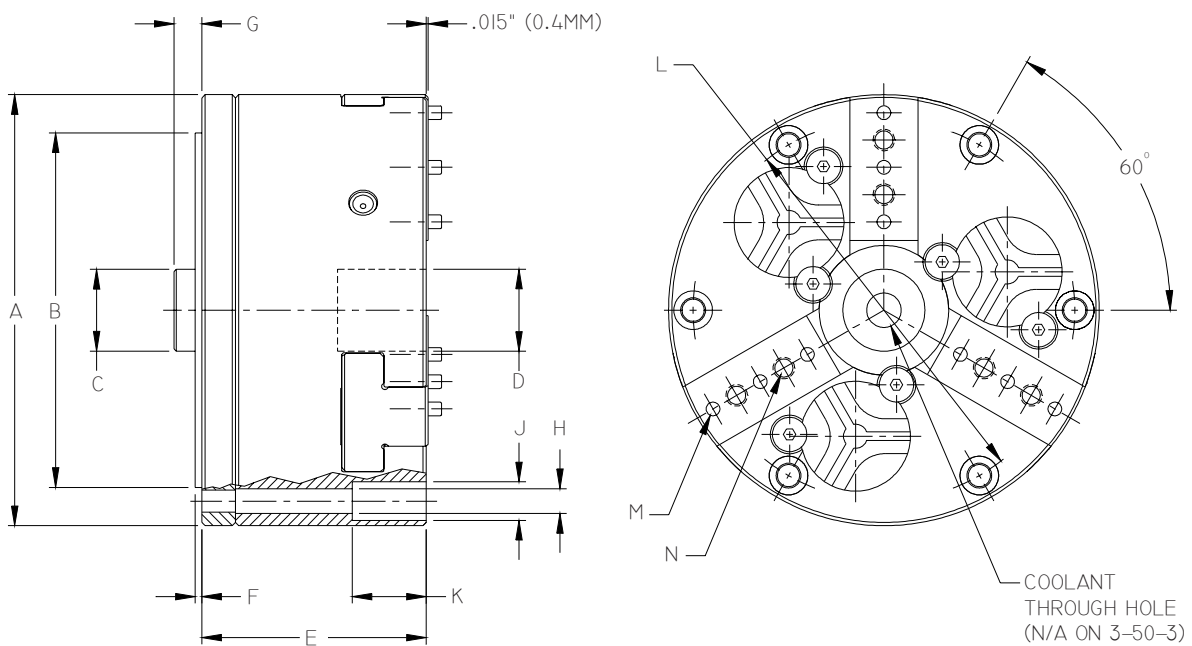

Standard Equipment

- One set steel top jaws
- Grease gun and lubricant

Chuck Accessories

- Air tube assemblies - page 17
- Air controls - page 18
- Blank top jaws - page 19
- Chuck lubricant - page 22

Stationary Air Chucks



Stationary air chucks are ideal for milling, drilling, tapping, and other applications requiring a compact self-contained workholding fixture. Air is supplied directly into the side of the chuck body, and the chuck can be mounted directly to the machine table or pallet. Through holes are available on all models.

Chuck Accuracy

- .00005" (0.0012mm) TIR is standard
- .00002" (0.0005mm) TIR is available

Stationary Air Chuck Specifications

Chuck Size	Chuck Model	# of Jaws*	Chuck Accuracy**	Jaw Stroke***	Max. Clamp Force	Max. air Pressure	Through Hole Dia.	Chuck Weight
3 inch 80 mm	3-50NR12-3	3	.00005"	.050"	304 lb/jaw	100 psi	.475"	3 lb
			.0012 mm	1.3 mm	138 kg/jaw	7.0 kg/cm ²	12.0mm	1.4 kg
4 inch 100 mm	4-40NR19-3	3	.00005"	.040"	568 lb/jaw	100 psi	.750"	6 lb
	4-120NR19-3	3	.0025 mm	1.0 mm	258 kg/jaw	7.0 kg/cm ²	19.1mm	2.7 kg
6 inch 150 mm	6-40NR-3	3	.00005"	.120"	568 lb/jaw	100 psi	.750"	7 lb
			.0012 mm	3.0 mm	258 kg/jaw	7.0 kg/cm ²	19.1mm	3.2 kg
	6-40NR34-3	3	.00005"	.040"	867 lb/jaw	100 psi	1.000"	14 lb
			.0012 mm	1.0 mm	394 kg/jaw	7.0 kg/cm ²	25.4mm	6.4 kg
	6-120NR-3	3	.00005"	.040"	815 lb/jaw	100 psi	1.330"	13 lb
			.0012 mm	1.0 mm	370 kg/jaw	7.0 kg/cm ²	33.8mm	5.7 kg
6-120NR34-3	3	.00005"	.120"	867 lb/jaw	100 psi	1.000"	16 lb	
		.0012 mm	3.0 mm	394 kg/jaw	7.0 kg/cm ²	25.4mm	7.3 kg	
8 inch 200 mm	8-120NR-3	3	.00005"	.120"	815 lb/jaw	100 psi	1.330"	15 lb
	8-120NR34-3	3	.0012 mm	3.0 mm	370 kg/jaw	7.0 kg/cm ²	33.8mm	6.8 kg
10 inch 250 mm	10-220NR-3	3	.00005"	.120"	1,628 lb/jaw	100 psi	.875"	40 lb
			.0012 mm	3.0 mm	740 kg/jaw	7.0 kg/cm ²	22.2mm	18.2 kg
10-220NR76-3	3	.00005"	.120"	1,498 lb/jaw	100 psi	2.000"	37 lb	
		.0012 mm	3.0 mm	681 kg/jaw	7.0 kg/cm ²	50.8mm	17 kg	
10-220NR76-3	3	.00005"	.220"	2,548 lb/jaw	100 psi	1.000"	77 lb	
		.0012 mm	5.6 mm	1,158 kg/jaw	7.0 kg/cm ²	25.4mm	35 kg	
10-220NR76-3	3	.00005"	.220"	2,344 lb/jaw	100 psi	3.000"	69 lb	
		.0012 mm	5.6 mm	1,065 kg/jaw	7.0 kg/cm ²	76.2mm	31 kg	

*2 jaw configurations available for all air chuck sizes, 6 jaw configurations available on 10 inch (250 mm) models

**Chuck accuracy is defined as the total indicator reading (maximum radial and lateral runout) of a master gage measured 1.0" (25 mm) from the face of a standard top jaw

***Total jaw stroke (on diameter)

Available Options (see pages 15 to 16)

- QC (QC Jaw System) - Precision located top jaw system
- UP (Ultra Precision) - Chucking accuracy within .00002" (0.0005mm)
- AL (Auto-Lube) - Lubrication passage in side of chuck body

Stationary Air Chuck Dimensions

Model		A	B	C	D	E	F	G	H	J	K	L	M	N
3-50NR12-3	inch	3.175	2.000	0.425	0.755	1.535	0.060	0.300	0.203	0.354	0.125	M5	2.750	M5
	mm	80.6	50.8	10.8	19.2	39.0	1.5	7.6	5.2	9.0	3.2	M5	69.9	M5
4-40NR19-3	inch	3.950	3.249	0.560	1.070	2.060	0.060	0.680	0.203	0.354	0.125	M5	3.500	1/8 NPT
	mm	100.3	82.5	14.2	27.2	52.3	1.5	17.3	5.2	9.0	3.2	M5	88.9	1/8 NPT
4-120NR19-3	inch	3.950	3.249	0.560	1.290	2.460	0.060	0.860	0.203	0.354	0.125	M5	3.500	1/8 NPT
	mm	100.3	82.5	14.2	32.8	62.5	1.5	21.8	5.2	9.0	3.2	M5	88.9	1/8 NPT
6-40NR-3	inch	5.950	4.920	0.560	1.070	2.060	0.120	0.680	0.265	0.430	0.125	M5	5.350	1/8 NPT
	mm	151.1	125.0	14.2	27.2	52.3	3.0	17.3	6.7	10.9	3.2	M5	135.9	1/8 NPT
6-40NR34-3	inch	5.950	4.920	0.560	1.070	2.060	0.120	0.680	0.265	0.430	0.125	M5	5.350	1/8 NPT
	mm	151.1	125.0	14.2	27.2	52.3	3.0	17.3	6.7	10.9	3.2	M5	135.9	1/8 NPT
6-120NR-3	inch	5.950	4.920	0.560	1.290	2.460	0.120	0.860	0.265	0.430	0.125	M5	5.350	1/8 NPT
	mm	151.1	125.0	14.2	32.8	62.5	3.0	21.8	6.7	10.9	3.2	M5	135.9	1/8 NPT
6-120NR34-3	inch	5.950	4.920	0.560	1.290	2.460	0.120	0.860	0.265	0.430	0.125	M5	5.350	1/8 NPT
	mm	151.1	125.0	14.2	32.8	62.5	3.0	21.8	6.7	10.9	3.2	M5	135.9	1/8 NPT
8-120NR-3	inch	8.000	6.600	0.750	1.625	3.428	0.135	0.500	0.421	0.656	0.250	M10	7.200	1/4 NPT
	mm	203.2	167.6	19.1	41.3	87.1	3.4	12.7	10.7	16.7	6.4	M10	182.9	1/4 NPT
8-120NR50-3	inch	8.000	6.600	0.750	1.625	3.428	0.135	0.500	0.421	0.656	0.250	M10	7.200	1/4 NPT
	mm	203.2	167.6	19.1	41.3	87.1	3.4	12.7	10.7	16.7	6.4	M10	182.9	1/4 NPT
10-220NR-3	inch	10.000	8.500	0.875	2.250	4.000	0.190	1.520	0.421	0.656	0.250	M10	9.200	1/4 NPT
	mm	254.0	215.9	22.2	57.2	101.6	4.8	38.6	10.7	16.7	6.4	M10	233.7	1/4 NPT
10-220NR77-3	inch	10.000	8.500	0.830	2.250	4.000	0.190	1.520	0.421	0.656	0.250	M10	9.200	1/4 NPT
	mm	254.0	215.9	21.1	57.2	101.6	4.8	38.6	10.7	16.7	6.4	M10	233.7	1/4 NPT

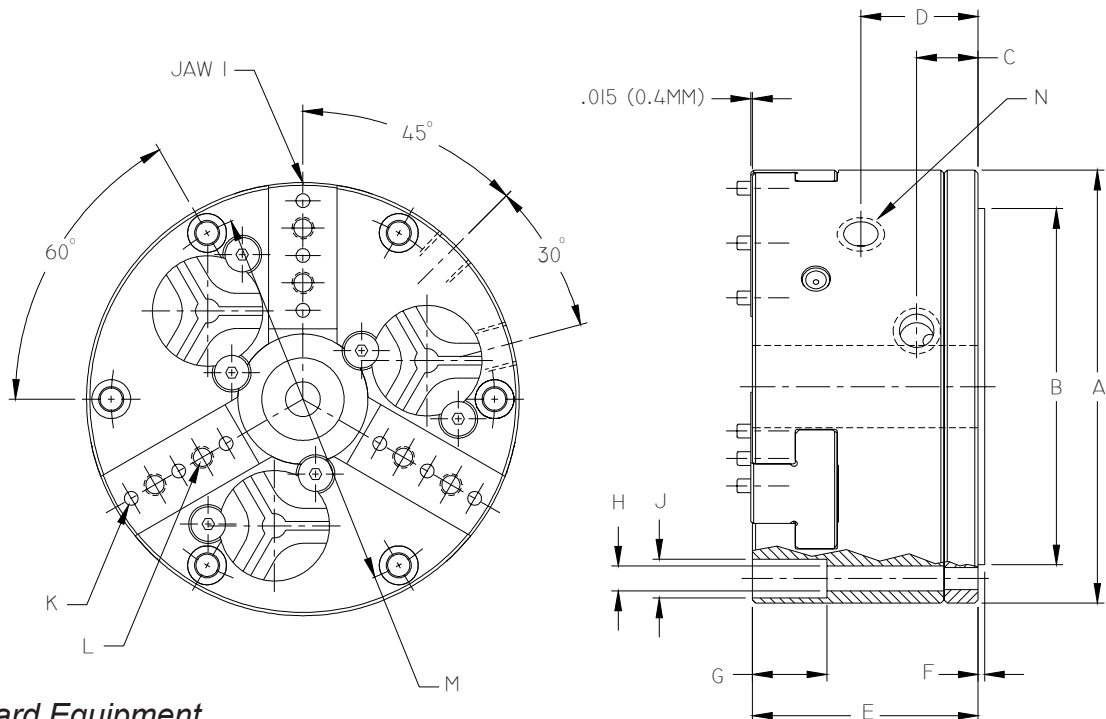

Standard Equipment

- One set steel top jaws
- Grease gun and lubricant

Chuck Accessories

- Air controls - page 18
- Blank top jaws - page 19
- Chuck lubricant - page 22

Long Stroke Air Chucks



Long stroke air chucks feature extended jaw opening for load clearance or to clamp a range of diameters without changing top jaws. Long stroke chucks are available in rotating and stationary configurations. Their high accuracy makes them ideal for clamping headed workpieces for turning, grinding, or milling/drilling applications.

Special models with total jaw stroke of .500" (12.7mm), .750" (19.1mm), and 1.000" (24.5mm) are also available. Please call for information.

Chuck Accuracy

- .00005" (0.0012mm) TIR is standard
- .00002" (0.0005mm) TIR is available

Long Stroke Air Chuck Specifications

Chuck Size	Chuck Model	# of Jaws*	Chuck Accuracy**	Jaw Stroke***	Max. Clamp Force	Max. air Pressure	Max. rpm****	Chuck Weight
4 inch 100 mm	4-360-3	3	.00005" .0012 mm	.360" 9.1 mm	437 lb/jaw 199 kg/jaw	100 psi 7.0 kg/cm ²	4,000	8 lb 3.6 kg
6 inch 150 mm	6-360-3	3	.00005" .0012 mm	.360" 9.1 mm	685 lb/jaw 311 kg/jaw	100 psi 7.0 kg/cm ²	3,000	19 lb 8.6 kg
8 inch 200 mm	8-360-3	3	.00005" .0012 mm	.360" 9.1 mm	1,254 lb/jaw 570 kg/jaw	100 psi 7.0 kg/cm ²	2,500	45 lb 20 kg
10 inch 250 mm	10-400-3	3	.00005" .0012 mm	.400" 10.2 mm	1,936 lb/jaw 880 kg/jaw	100 psi 7.0 kg/cm ²	2,000	77 lb 35 kg

*2 jaw configurations available for all air chuck sizes, 6 jaw configurations available on 10 inch (250 mm) models

**Chuck accuracy is defined as the total indicator reading (maximum radial and lateral runout) of a master gage measured 1.0" (25 mm) from the face of a standard top jaw

***Total jaw stroke (on diameter)

****Max. rpm is influenced by air pressure and mass of top jaws

Available Options (see pages 15 to 16)

- QC (QC Jaw System) - Precision located top jaw system
- UP (Ultra Precision) - Chucking accuracy within .00002" (0.0005mm)
- AL (Auto-Lube) - Lubrication passage through center of air tube
- BP (Back Ported) - Through hole design with air ports in back of chuck
- NR (Non-Rotating) - Air ports on side of chuck body for stationary use

Long Stroke Air Chuck Dimensions

Model		A	B	C	D	E	F	G min	G max	H	J	K	L	M	N
4-360-3/MM	inch	3.950	3.249	0.749	n/a	3.010	0.060	0.059	0.724	0.203	0.354	1.375	3.500	0.125	M5
	mm	100.3	82.5	19.0	n/a	76.5	1.5	1.5	18.4	5.2	9.0	34.9	88.9	3.2	M5
6-360-3/MM	inch	5.950	4.920	0.749	1.000	3.010	0.120	0.052	0.724	0.265	0.430	0.860	5.350	0.125	M5
	mm	151.1	125.0	19.0	25.4	76.5	3.0	1.3	18.4	6.7	10.9	21.8	135.9	3.2	M5
8-360-3	inch	8.000	6.600	1.188	1.010	3.875	0.135	0.658	0.658	0.421	0.656	0.500	7.200	0.250	M10
	mm	203.2	167.6	30.2	25.7	98.4	3.4	16.7	16.7	10.7	16.7	12.7	182.9	6.4	M10
10-400-3	inch	10.000	8.500	1.188	1.193	4.000	0.190	0.561	0.561	0.421	0.656	1.520	9.200	0.250	M10
	mm	254.0	215.9	30.2	30.3	101.6	4.8	14.2	14.2	10.7	16.7	38.6	233.7	6.4	M10

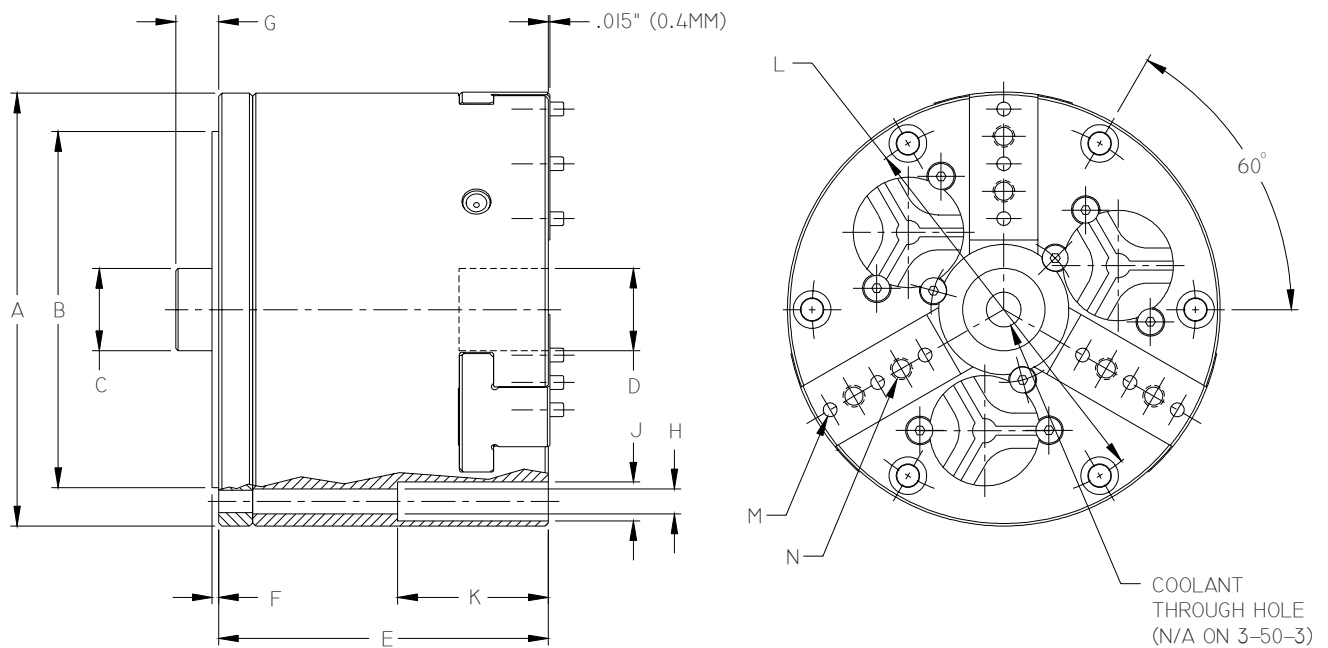

Standard Equipment

- One set steel top jaws
- Grease gun and lubricant

Chuck Accessories

- Air tube assemblies - page 17
- Air controls - page 18
- Blank top jaws - page 19
- Chuck lubricant - page 22

HST High Speed Air Chucks



HST High Speed Air Chucks feature a titanium chuck body and are actuated by a patented external wedge design that maintains clamping force at high spindle speeds without counterweights. This revolutionary design minimizes the effects of centrifugal force resulting in consistent clamping force throughout the chuck's rpm range.

HST chucks are available in standard, HS, and BP models. The HS models are dynamically balanced and feature MicroCentric's patented NR50 non-rotating air tube system. The NR50 design eliminates vibration caused by rotating air at higher spindle speeds, thus enhancing a machine's surface finish, and roundness capability.

Chuck Accuracy

- .0001" (0.0025mm) TIR is standard
- .00005" (0.0012mm) TIR is available

HST Air Chuck Specifications

Chuck Size	Chuck Model	# of Jaws	Chuck Accuracy*	Jaw Stroke**	Max. Clamp Force	Max. air Pressure	Max. rpm***	Chuck Weight
3 inch 80 mm	HST3-3	3	.0001" .0025 mm	.080" 2.0 mm	484 lb/jaw 220 kg/jaw	100 psi 7.0 kg/cm2	6,000	4.4 lb 2.0 kg
	HST-3/HS	3	.0001" .0025 mm	.080" 2.0 mm	484 lb/jaw 220 kg/jaw	100 psi 7.0 kg/cm2	10,000	4.4 lb 2.0 kg
4 inch 100 mm	HST4-3	3	.0001" .0025 mm	.100" 2.5 mm	642 lb/jaw 292 kg/jaw	100 psi 7.0 kg/cm2	6,000	9.0 lb 4.1 kg
	HST4-3/HS	3	.0001" .0025 mm	.100" 2.5 mm	642 lb/jaw 292 kg/jaw	100 psi 7.0 kg/cm2	9,000	9.0 lb 3.2 kg
6 inch 150 mm	HST6-3	3	.0001" .0025 mm	.100" 2.5 mm	933 lb/jaw 424 kg/jaw	100 psi 7.0 kg/cm2	6,000	15.6 lb 7.1 kg
	HST6-3/HS	3	.0001" .0025 mm	.100" 2.5 mm	933 lb/jaw 424 kg/jaw	100 psi 7.0 kg/cm2	8,000	15.6 lb 7.1 kg

*Chuck accuracy is defined as the total indicator reading (maximum radial and lateral runout) of a master gage measured 1.0" (25 mm) from the face of a standard top jaw

**Total jaw stroke (on diameter)

***Max. rpm is influenced by air pressure and mass of top jaws

Available Options (see pages 15 to 16)

- QC (QC Jaw System) - Precision located top jaw system
- UP (Ultra Precision) - Chucking accuracy within .00005" (0.0012mm)
- AL (Auto-Lube) - Lubrication passage through center of air tube
- BP (Back Ported) - Through hole design with air ports in back of chuck

HST Air Chuck Dimensions

Model		A	B	C	D	E	F	G	H	J	K
HST3-3	inch	3.000	5.137	2.249	2.416	0.000	1.670	4.540	M5	1.750	35°
	mm	76.2	130.5	57.1	61.4	0.0	42.4	115.3	M5	44.5	35°
HST3-3/HS	inch	3.000	5.137	2.249	2.416	0.504	1.670	4.540	M5	1.750	35°
	mm	76.2	130.5	57.1	61.4	12.8	42.4	115.3	M5	44.5	35°
HST4-3	inch	4.000	5.990	3.000	3.140	-0.303	n/a	n/a	M6	2.250	40°
	mm	101.6	152.1	76.2	79.8	-7.7	n/a	n/a	M6	57.2	40°
HST4-3/HS	inch	4.000	5.990	3.000	3.140	0.201	n/a	n/a	M6	2.250	40°
	mm	101.6	152.1	76.2	79.8	5.1	n/a	n/a	M6	57.2	40°
HST6-3	inch	5.875	7.990	4.000	3.140	-0.312	n/a	n/a	M8	3.250	60°
	mm	149.2	202.9	101.6	79.8	-7.9	n/a	n/a	M8	82.6	60°
HST6-3/HS	inch	5.875	7.990	4.000	3.140	0.192	n/a	n/a	M8	3.250	60°
	mm	149.2	202.9	101.6	79.8	4.9	n/a	n/a	M8	82.6	60°

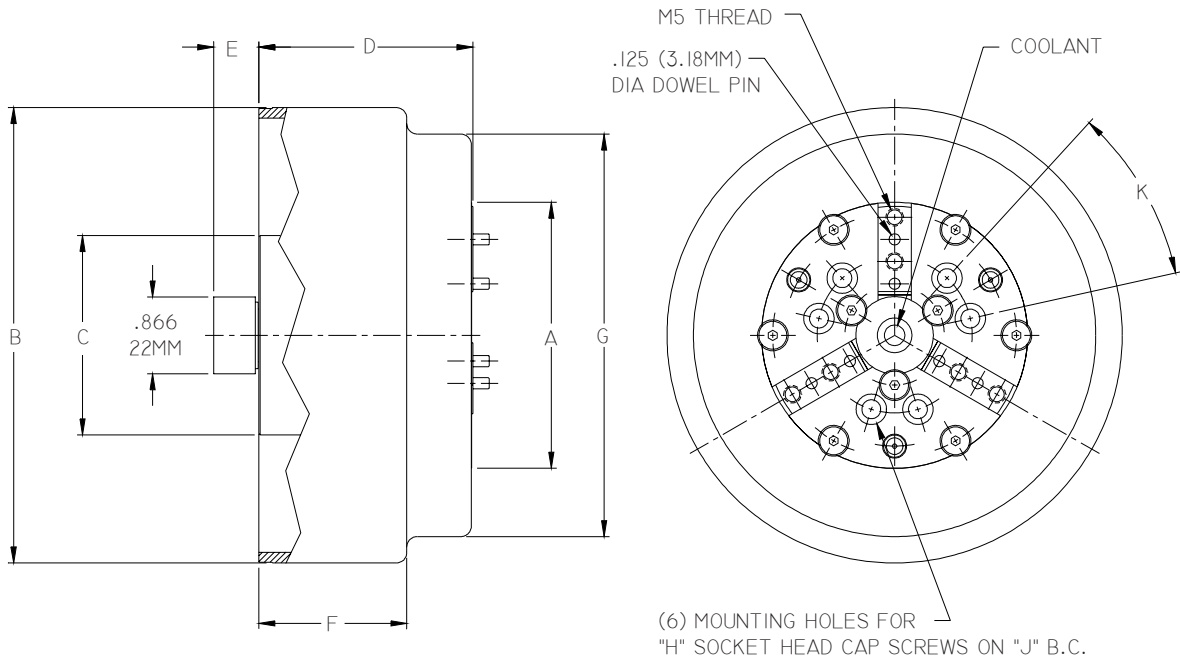

Dynamic Jaw Force Graph

Standard Equipment

- One set steel top jaws
- Grease gun and lubricant

Chuck Accessories

- Air tube assemblies - page 17
- Air controls - page 18
- Blank top jaws - page 19
- Chuck lubricant - page 22

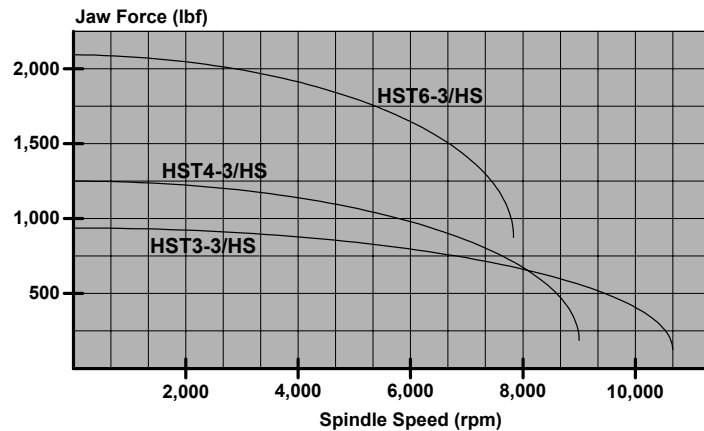

Sealed Air Chucks



Sealed air chucks feature a stainless steel cover that seals the jaw slides. This design prevents contamination from grit and swarf and minimizes chuck maintenance for high volume production operations. Sealed air chucks are available in rotating and stationary configurations and are ideal for cylindrical grinding operations as well as machining abrasive materials such as powdered metal, ceramic, or carbide.

QC precision located top jaw system is standard on sealed air chucks.

Chuck Accuracy

- .00005" (0.0012mm) TIR is standard
- .00002" (0.0005mm) TIR is available

Sealed Air Chuck Specifications

Chuck Size	Chuck Model	# of Jaws*	Chuck Accuracy**	Jaw Stroke***	Max. Clamp Force	Max. air Pressure	Max. rpm****	Chuck Weight
3 inch 80 mm	SC/34-50-3	3	.00005" .0012 mm	.050" 1.3 mm	392 lb/jaw 178 kg/jaw	100 psi 7.0 kg/cm2	6,000	4 lb 1.8 kg
4 inch 100 mm	SC/45-120-3	3	.00005" .0012 mm	.120" 3.0 mm	700 lb/jaw 318 kg/jaw	100 psi 7.0 kg/cm2	6,000	11 lb 5 kg
6 inch 150 mm	SC/67-120-3	3	.00005" .0012 mm	.120" 3.0 mm	1,065 lb/jaw 484 kg/jaw	100 psi 7.0 kg/cm2	4,000	22 lb 10 kg

*2 jaw configurations available for all air chuck sizes

**Chuck accuracy is defined as the total indicator reading (maximum radial and lateral runout) of a master gage measured 1.0" (25 mm) from the face of a standard top jaw

***Total jaw stroke (on diameter)

****Max. rpm is influenced by air pressure and mass of top jaws

Available Options (see pages 15 to 16)

- UP (Ultra Precision) - Chucking accuracy within .00002" (0.0005mm)
- BP (Back Ported) - Through hole design with air ports in back of chuck
- NR (Non-Rotating) - Air ports on side of chuck body for stationary use
- C (Coolant Thru) - Coolant passage in center of chuck

Sealed Air Chuck Dimensions

Model		A	B	C	D	E	F	G	H	J	K	L
34-50-3/SC/QC	inch	3.950	2.000	0.749	1.905	0.060	0.161	0.172	0.302	1.255	3.531	M5
	mm	100.3	50.8	19.0	48.4	1.5	4.1	4.4	7.7	31.9	89.7	M5
45-120-3/SC/QC	inch	4.950	4.000	0.749	2.585	0.060	0.249	0.203	0.354	1.255	4.500	M5
	mm	125.7	101.6	19.0	65.7	1.5	6.3	5.2	9.0	31.9	114.3	M5
67-120-3/SC/QC	inch	7.000	5.750	0.749	2.650	0.065	0.184	0.265	0.413	1.255	6.500	M8
	mm	177.8	146.1	19.0	67.3	1.7	4.7	6.7	10.5	31.9	165.1	M8

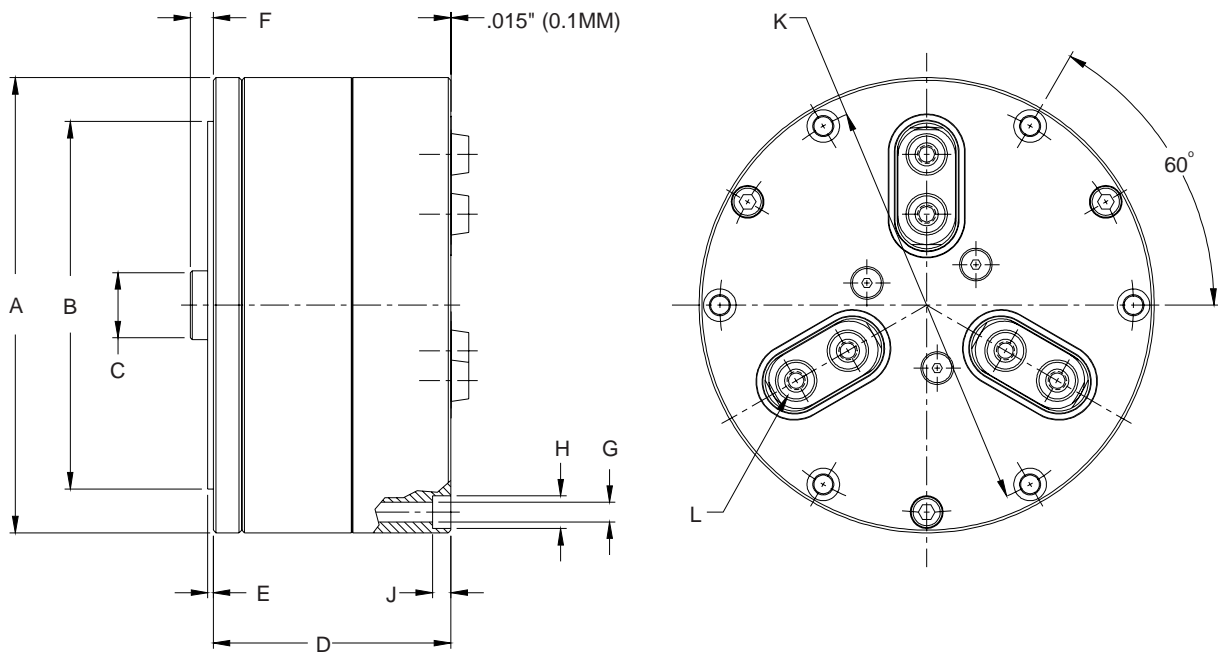

Chuck Accessories

- Air tube assemblies - page 17
- Air controls - page 18
- Blank top jaws - page 19
- Chuck lubricant - page 22

Large Diameter Air Chucks



Large Diameter Air Chucks offer high accuracy and adjustable clamping force for machining large diameter precision and thin-walled workpieces. Large Diameter chucks are available in three jaw as well as two and six jaw configurations. Large Diameter models with extended jaw stroke, air ports on OD of chuck body for stationary applications, and other special configurations are quoted upon request.

Chuck Accuracy

- .0002" (0.005mm) TIR is standard
- .0001" (0.0025mm) TIR is available

Large Diameter Air Chuck Specifications

Chuck Size	Chuck Model	# of Jaws*	Chuck Accuracy**	Jaw Stroke***	Max. Clamp Force	Max. air Pressure	Max. rpm****	Chuck Weight
12 inch 300 mm	12-220-3	3	.0002" .005 mm	.220" 5.6 mm	2,904 lb/jaw 1,320 kg/jaw	90 psi 6.5 kg/cm2	2,250	131 lb 60 kg
	12-400-3	3	.0002" .005 mm	.400" 10.2 mm	2,236 lb/jaw 1,016 kg/jaw	90 psi 6.5 kg/cm2	1,850	131 b 60 kg
14 inch 350 mm	14-220-3	3	.0002" .005 mm	.220" 5.6 mm	3,971 lb/jaw 1,805 kg/jaw	90 psi 6.5 kg/cm2	2,250	156 lb 72 kg
	14-400-3	3	.0002" .005 mm	.400" 10.2 mm	3,018 lb/jaw 1,372 kg/jaw	90 psi 6.5 kg/cm2	1,850	156 b 72 kg
16 inch 400 mm	16-220-3	3	.0002" .005 mm	.250" 6.4 mm	4,961 lb/jaw 2,255 kg/jaw	90 psi 6.5 kg/cm2	2,000	320 lb 146 kg
	16-400-3	3	.0002" .005 mm	.400" 10.2 mm	3,721 lb/jaw 1,691 kg/jaw	90 psi 6.5 kg/cm2	1,500	320 b 146 kg

*2 jaw and 6 jaw configurations available for all air chuck sizes
 **Chuck accuracy is defined as the total indicator reading (maximum radial and lateral runout) of a master gage measured 1.0" (25 mm) from the face of a standard top jaw

***Total jaw stroke (on diameter)

****Max. rpm is influenced by air pressure and mass of top jaws

Available Options (see pages 15 to 16)

- QC (QC Jaw System) - Precision located top jaw system
- UP (Ultra Precision) - Chucking accuracy within .0001" (0.0025mm)
- AL (Auto-Lube) - Lubrication passage through center of air tube
- BP (Back Ported) - Through hole design with air ports in back of chuck
- NR (Non-Rotating) - Air ports on side of chuck body for stationary use

Large Diameter Air Chuck Dimensions

Model		A	B	C	D	E	F	G	H	J	K	L	M	N
12-220-3	inch	11.950	9.750	1.188	1.193	4.000	0.250	0.561	0.531	0.781	1.520	10.500	0.250	M10
	mm	303.5	247.7	30.2	1.193	101.6	6.4	14.2	13.5	19.8	38.6	266.7	6.4	M10
12-400-3	inch	11.950	9.750	1.188	1.193	4.000	0.250	0.561	0.531	0.781	1.520	10.500	0.250	M10
	mm	303.5	247.7	30.2	1.193	101.6	6.4	14.2	13.5	19.8	38.6	266.7	6.4	M10
14-220-3	inch	13.950	11.000	1.188	n/a	4.125	0.250	0.418	0.656	1.000	0.700	12.500	0.250	M10
	mm	354.3	279.4	30.2	n/a	104.8	6.4	10.6	16.7	25.4	17.8	317.5	6.4	M10
14-400-3	inch	13.950	11.000	1.188	n/a	4.125	0.250	0.418	0.656	1.000	0.700	12.500	0.250	M10
	mm	354.3	279.4	30.2	n/a	104.8	6.4	10.6	16.7	25.4	17.8	317.5	6.4	M10
16-220-3	inch	16.000	12.000	1.188	n/a	5.500	0.250	0.235	0.687	1.000	0.750	14.000	0.375	M12
	mm	406.4	304.8	30.2	n/a	139.7	6.4	6.0	17.4	25.4	19.1	355.6	9.5	M12
16-400-3	inch	16.000	12.000	1.188	n/a	5.500	0.250	0.235	0.687	1.000	0.750	14.000	0.375	M12
	mm	406.4	304.8	30.2	n/a	139.7	6.4	6.0	17.4	25.4	19.1	355.6	9.5	M12

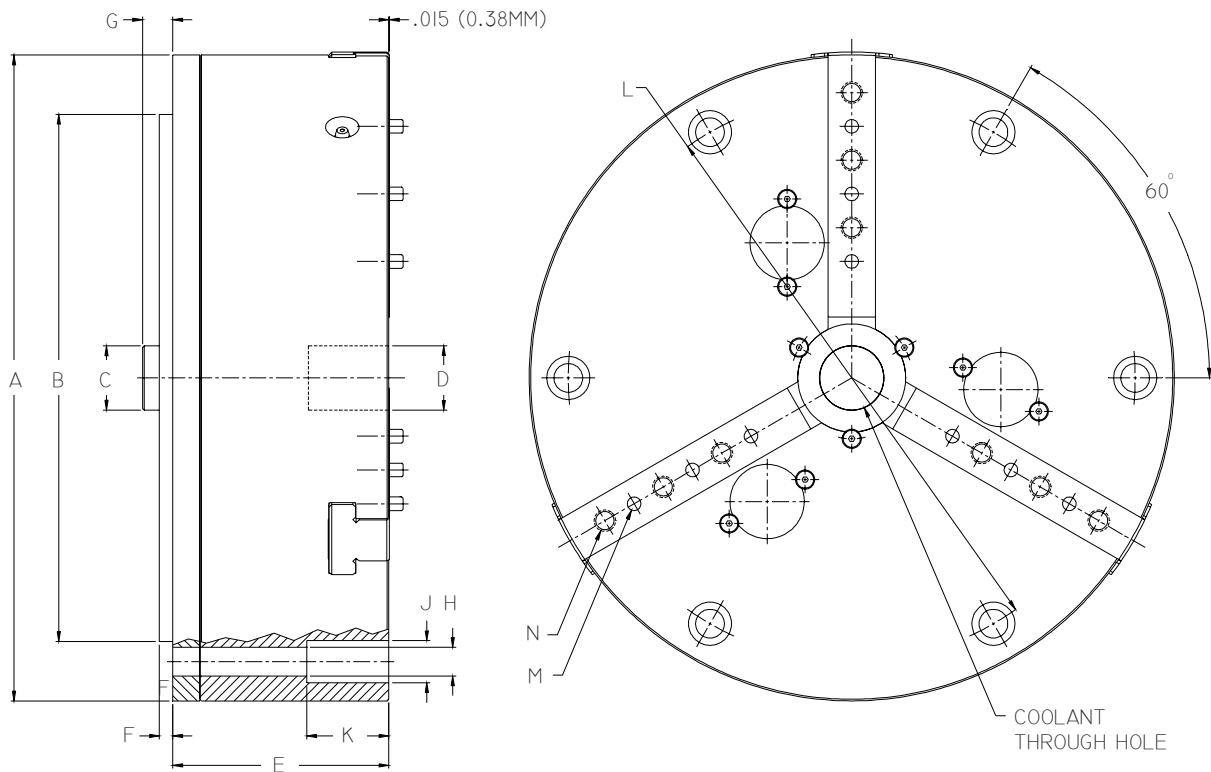

Standard Equipment

- One set steel top jaws
- Grease gun and lubricant

Chuck Accessories

- Air tube assemblies - page 17
- Air controls - page 18
- Blank top jaws - page 19
- Chuck lubricant - page 22

Options for MicroCentric Chucks

QC Quick Change Top Jaw System



Patented jaw locating system reduces setup time by maintaining .0002" (0.005mm) TIR accuracy after jaw change, without remachining top jaws.

MicroCentric's QC precision locating jaw system reduces setup time and increases a machine's flexibility for JIT scheduling by eliminating the time consuming process of remachining top jaws after change over. QC top jaws can also be machined "off-line" on a QC Jaw Turning Fixture or on another QC chuck.

QC System Accuracies

- .0002" TIR when jaws are machined and replaced on the same chuck.
- .0008" TIR when jaws are machined on another chuck or on a QC turning fixture.

QC System Features

- Blank QC top jaws are made from A-2 tool steel that can be hardened to Rc 60 without distorting the tapered locating holes.
- QC Jaw Turning fixtures are available to machine top jaws "off-line" and maximize a machine's run time.
- Custom hardened and ground QC top jaws can be designed for specific workpiece applications are quoted on request.

QC System Design

QC top jaws are located by two tapered locating buttons that are pressed into jig ground locating holes in the chuck's base jaws. QC top jaws feature jig ground tapered locating holes that mate with the tapered locating buttons on the chuck's base jaws. Due to the close tolerances that are held on both the tapered locating buttons and locating holes, the top jaw seats on the OD of the button as well as on the face of the master jaw. This precision fit eliminates clearance and assures high locating accuracy and rigidity.

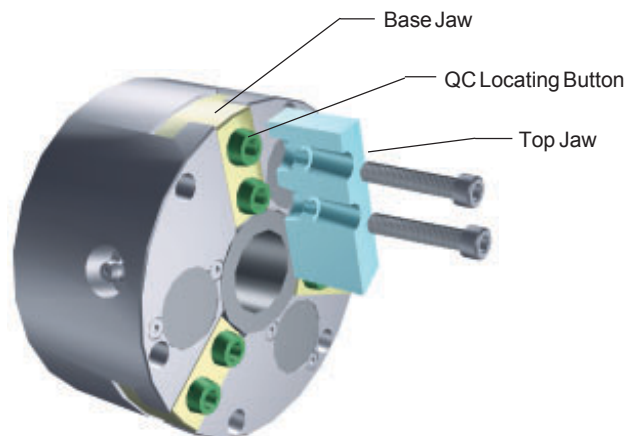

UP Ultra Precision Option

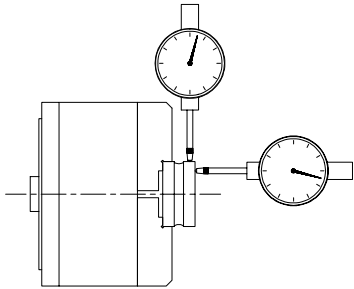

Repeating accuracy to .000020" (0.0005mm) TIR

For applications which require extremely close chucking accuracy, MicroCentric will selectively fit and certify a chuck to an accuracy of .000050" (0.001mm) or .000020" (0.0005mm) depending on model.

Note that temperature variations, changes in air pressure, spindle runout, and the condition and design of top jaws will affect chuck accuracy.

AL Automatic Lubrication Option

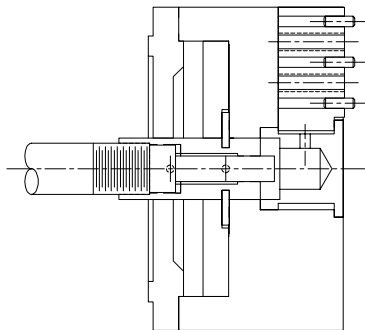

Lubricate the chuck with an electric pump

The AL option allows lubricant to be supplied to the chuck through the air tube assembly during the machine cycle. This option is recommended for unmanned machine cells and other high volume production applications.

An AL chuck is equipped with a special center housing that channels the lubricant to the moving components within the chuck. The machine's way lubrication pump is typically used to also supply lubricant to the chuck.

For rotating applications a rotary union must be adapted to the air tube assembly in order to provide a connection for the lubrication line. The AL Option is also available on Stationary Chucks.

BP Back Ported Option

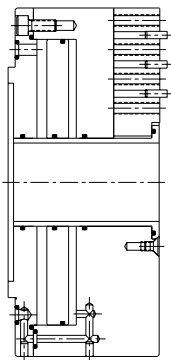

Air passages through the back cover provides a hole in the center of the chuck

For applications where the workpiece must be swallowed into the center of the chuck. The BP design also enables housings with part stops or parts ejectors to be mounted into the ID of the chuck.

Air is typically supplied to BP chucks through the mounting plate which can be supplied with the chuck.

Air Tube Assemblies

Rotating Air Tubes



Air tube assemblies are used with all rotating MicroCentric air chucks. The rotary air coupling features a hardened steel journal and a maintenance free oil-lite bearing.

Rotary air tubes include a blank support bushing, air hoses and fittings. Length to be specified when ordering. Contact our sales department for assistance in determining the correct length for your application.

Air Tube	Chucks used with:
Model 30	3-50
Model 50	3-50C, 4 & 6 inch, & HST models
Model 82	8 to 16 inch models

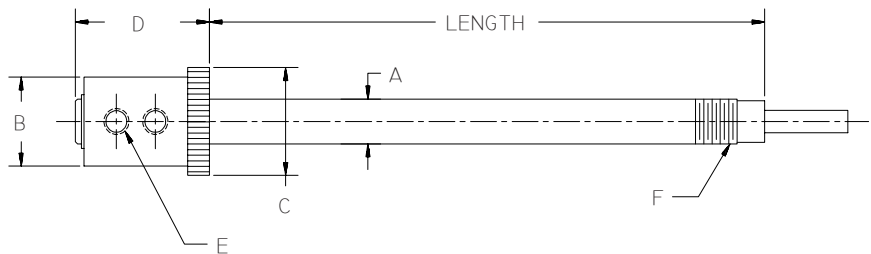

Air Tube	A	B	C	D	E	F	Max Speed
Model 30	.375" 9.5mm	1.00" 25.4mm	1.25" 31.8mm	1.87" 47.5mm	#10-32 UNF	3/8"-32 UNF	6,000 rpm
Model 50	.625" 15.9mm	1.24" 31.5mm	1.50" 38.1mm	2.21" 56.1mm	1/16"-27 NPT	5/8"-32 UNF	6,000 rpm
Model 82	1.00" 25.4mm	2.50" 63.5mm	2.75" 69.9mm	4.85" 123.2mm	1/4"-18 NPT	1.0"-24 UNF	4,000 rpm

NR50 High Speed - Non Rotating Air Tube



MicroCentric's patented NR50 air tube is used with HST/HS chucks. This air tube couples to a rotary air journal mounted in the ID HST/HS chucks. The NR50 is a three passage design for coolant through the spindle or automatic lubrication.

NR50 air tubes include air hoses and fittings. A support bushing is required to fix the tube to the rear of the machine spindle. Contact our sales department for additional information.

Max Speed: 10,000 rpm

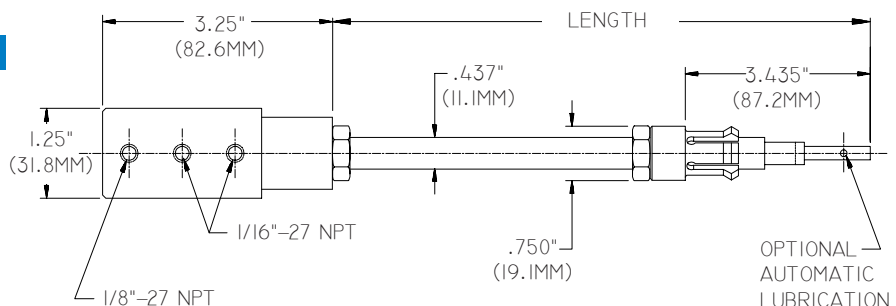

Air Controls

Operating Valves



HV operating valves are three position manually operated pneumatic valves that direct air flow to open and close MicroCentric air chucks.

Each HV valve includes air hoses and fittings required for installation.

Model	Fitting Size	Max Pressure	Air Tube Model
HV-10	1/8"-27 NPT	150 psi	Model 30 and 50
		12 kg/cm ²	
HV-20	1/4"-18 NPT	150 psi	Model 82
		12 kg/cm ²	

Air Filter/Regulator/Lubricator Units



The FRL-15 is a combination air filter/regulator/lubricator unit that controls the air pressure to the chuck's built-in cylinder, and provides lubrication to the rotary air bearing assembly. This unit also filters contaminants from the air supply. Water that accumulates in the filter unit can be purged by a manual drain.

Each unit includes a pressure gage, as well as air hoses and fittings.

Model	Fitting Size	Max Pressure
FRL-15	1/4"-18 NPT	150 psi
		12 kg/cm ²

Rotary Union



A rotary union is required to supply coolant through the air tube assembly, or for the AL-Automatic Lubrication option.

The rotary union threads into the rear of the air tube and includes a hose and fittings.

Model	Fitting Size	Max Pressure	Max Speed	Air Tube Model
RU-10	1/8"-27 NPT	150 psi	6,000 rpm	Model 50
		12 kg/cm ²		
RU-20	1/4"-18 NPT	150 psi	4,000 rpm	Model 82
		12 kg/cm ²		

Blank Top Jaws

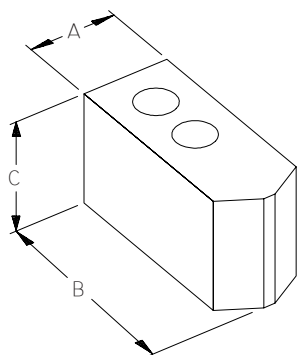

Steel jaw blanks can be carburized after rough machining, and then finish ground on the chuck.

Blank jaws are available in other configurations and materials. Contact our sales department for additional information.

MicroCentric specializes in designing and manufacturing custom top jaws for specific workpiece and machine applications. Fax a drawing of your part and we will prepare a quotation for custom top jaws, or we can make recommendations on top jaw design for your application.

MicroCentric Blank Top Jaws are manufactured to extremely close tolerances to assure proper fit onto MicroCentric chucks.

Blank jaws are typically machined on the chuck under load to suit the workpiece to be clamped. Detailed instructions on the design and preparation of top jaws is given in MicroCentric's installation and operating manual.

Chuck	Jaw Model	Material	A	B	C	Weight*
3 inch	3-100A	2024	.75" 19.1mm	1.55" 39.4mm	1.00" 25.4mm	.1 lb .05 kg
	3-100S	1018	.75" 19.1mm	1.55" 39.4mm	1.00" 25.4mm	.3 lb .13 kg
	3-200S	1018	.75" 19.1mm	1.55" 39.4mm	2.00" 50.8mm	.6 lb .27 kg
HST3	V3-100A	2024	.75" 19.1mm	1.52" 38.6mm	1.00" 25.4mm	.1 lb .05 kg
	V3-100S	1018	.75" 19.1mm	1.52" 38.6mm	1.00" 25.4mm	.3 lb .13 kg
	V3-150S	1018	.75" 19.1mm	1.52" 38.6mm	1.50" 38.1mm	.4 lb .18 kg
4 inch HST4	4-100A	2024	.75" 19.1mm	1.93" 49.0mm	1.00" 25.4mm	.1 lb .05 kg
	4-200A	2024	.75" 19.1mm	1.93" 49.0mm	2.00" 50.8mm	.2 lb .10 kg
	4-100S	1018	.75" 19.1mm	1.93" 49.0mm	1.00" 25.4mm	.4 lb .18 kg
	4-150S	1018	.75" 19.1mm	1.93" 49.0mm	1.50" 38.1mm	.4 lb .18 kg
	4-200S	1018	.75" 19.1mm	1.93" 49.0mm	2.00" 50.8mm	.7 lb .32 kg
	6 inch HST6	6-100A	2024	1.00" 25.4mm	2.96" 75.2mm	1.00" 25.4mm
	6-200A	2024	1.00" 25.4mm	2.96" 75.2mm	2.00" 50.8mm	.5 lb .23 kg
	6-300A	2024	1.00" 25.4mm	2.96" 75.2mm	3.00" 76.2mm	.7 lb .32 kg
	6-100S	1018	1.00" 25.4mm	2.96" 75.2mm	1.00" 25.4mm	.7 lb .32 kg
	6-150S	1018	1.00" 25.4mm	2.96" 75.2mm	1.50" 38.1mm	1.1 lb .5 kg
	6-200S	1018	1.00" 25.4mm	2.96" 75.2mm	2.00" 50.8mm	1.5 lb .68 kg
	6-300S	1018	1.00" 25.4mm	2.96" 75.2mm	3.00" 76.2mm	2.2 lb 1.0 kg
8 inch	8-200A	2024	1.50" 38.1mm	3.95" 100.3mm	2.00" 50.8mm	1.1 lb .50 kg
	8-300A	2024	1.50" 38.1mm	3.95" 100.3mm	3.00" 76.2mm	1.5 lb .68 kg
	8-200S	1018	1.50" 38.1mm	3.95" 100.3mm	2.00" 50.8mm	2.9 lb 1.3 kg
	8-300S	1018	1.50" 38.1mm	3.95" 100.3mm	3.00" 76.2mm	4.3 lb 1.9 kg
	10 inch	10-200A	2024	1.50" 38.1mm	4.95" 125.7mm	2.00" 50.8mm
	10-300A	2024	1.50" 38.1mm	4.95" 125.7mm	3.00" 76.2mm	1.8 lb .82 kg
	10-200S	1018	1.50" 38.1mm	4.95" 125.7mm	2.00" 50.8mm	3.6 lb 1.6 kg
	10-300S	1018	1.50" 38.1mm	4.95" 125.7mm	3.00" 76.2mm	5.3 lb 2.4 kg
12 inch	12-200A	2024	1.50" 34.1mm	5.72" 145.3mm	2.00" 50.8mm	1.5 lb .68 kg
	12-200S	1018	1.50" 34.1mm	5.72" 145.3mm	2.00" 50.8mm	4.3 lb 1.9 kg
	12-300S	1018	1.50" 34.1mm	5.72" 145.3mm	3.00" 76.2mm	6.4 lb 2.9 kg

*Weights are per piece

Blank Pie Shaped Jaws

Pie shaped jaws provide full circle contact with the workpiece. Pie Jaws are recommended for fragile and thin walled parts which are subject to distortion during clamping.

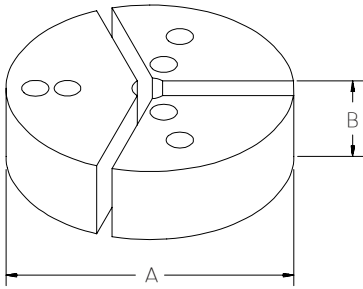

Blank pie jaws are available in other configurations and materials. Contact our sales department for additional information.

Chuck	Jaw Model	Material	A	B	Bore	Weight*
3 inch	3-101A	2024	3.18" 80.6mm	1.00" 25.4mm	.62" 15.1mm	.6 lb .27 kg
	3-101S	8620	3.18" 80.6mm	1.00" 25.4mm	.62" 15.1mm	1.8 lb .82 kg
HST3	V3-101A	2024	3.05" 77.5mm	1.00" 25.4mm	.62" 15.1mm	.5 lb .23 kg
	V3-101S	8620	3.05" 77.5mm	1.00" 25.4mm	.62" 15.1mm	1.6 lb .73 kg
4 inch HST4	4-101A	2024	3.95" 100.3mm	1.00" 25.4mm	.62" 15.1mm	1.0 lb .45 kg
	4-201A	2024	3.95" 100.3mm	2.00" 50.8mm	.62" 15.1mm	2.0 lb .9 kg
	4-101S	8620	3.95" 100.3mm	1.00" 25.4mm	.62" 15.1mm	2.9 lb 1.3 kg
	4-151S	8620	3.95" 100.3mm	1.50" 38.1mm	.62" 15.1mm	4.3 lb 2.0 kg
6 inch HST6	6-101A	2024	5.95" 151.1mm	1.00" 25.4mm	.88" 22.4mm	2.4 lb 1.1 kg
	6-201A	2024	5.95" 151.1mm	2.00" 50.8mm	.88" 22.4mm	4.8 lb 2.2 kg
	6-101S	8620	5.95" 151.1mm	1.00" 25.4mm	.88" 22.4mm	7.0 lb 3.2 kg
	6-151S	8620	5.95" 151.1mm	1.50" 38.1mm	.88" 22.4mm	10.4 lb 4.7 kg
	6-201S	8620	5.95" 151.1mm	2.00" 50.8mm	.88" 22.4mm	13.9 lb 6.3 kg
	8 inch	8-201A	2024	7.95" 201.9mm	2.00" 50.8mm	1.25" 31.8mm
	8-201S	8620	7.95" 201.9mm	2.00" 50.8mm	1.25" 31.8mm	25.2 lb 11.5 kg
10 inch	10-201A	2024	9.95" 252.7mm	2.00" 50.8mm	1.25" 31.8mm	14.1 lb 6.4 kg
	10-201S	8620	9.95" 252.7mm	2.00" 50.8mm	1.25" 31.8mm	40.9 lb 18.6 kg

*Weights are per set

Jaw Turning Fixtures

Jaw turning fixtures simulate the locating pattern of standard air chucks. They are used to rough turn blank top jaws off the chuck. It is recommended that jaws be finished bored on the chuck for best accuracy.

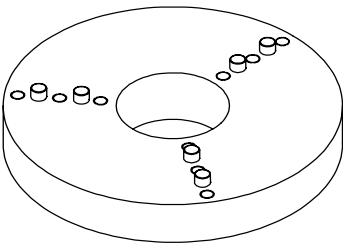

The clamping position of the jaw turning fixture is set in the middle of the chuck's stroke. Other positions are available upon request. Specify chuck model when ordering.

Chuck	Fixture Model	Outside Dia.	Thickness
3 inch	JTF-3	3.25"	.50"
		82.5mm	12.7mm
HST3	JTF-3V	3.25"	1.20"
		82.5mm	30.5mm
4 inch	JTF-4	4.25" 108mm	1.00" 25.4mm
6 inch	JTF-6	6.25" 158.8mm	1.00" 25.4mm
8 inch	JTF-8	8.5" 216mm	1.25" 31.7mm
10 inch	JTF-10	10.0" 254mm	1.75" 44.5mm

QC Blank Top Jaws

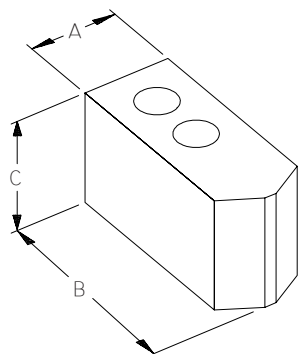

QC Blank Top Jaws are made from A-2 tool steel. They feature finished ground tapered locating holes, and can be rough and finish bored on a QC chuck or QC jaw turning fixture.

Other QC Blank Jaw configurations including pie-shaped are quoted on request.

Chuck	Model	Material	A	B	C	Weight*
4 inch	Q4-100S	A-2	.75" 19.0mm	1.93" 49.0mm	1.00" 25.4mm	.4 lb .18 kg
	Q4-150S	A-2	.75" 19.0mm	1.93" 49.0mm	1.50" 38.1mm	.5 lb .22 kg
	Q4-200S	A-2	.75" 19.0mm	1.93" 49.0mm	2.00" 50.8mm	.7 lb .31 kg
6 inch	Q6-100S	A-2	1.00" 25.4mm	2.96" 74.4mm	1.00" 25.4mm	.7 lb .31 kg
	Q6-150S	A-2	1.00" 25.4mm	2.96" 75.2mm	1.50" 38.1mm	1.0 lb .45 kg
	Q6-200S	A-2	1.00" 25.4mm	2.96" 75.2mm	2.00" 50.8mm	1.4 lb .63 kg
	Q6-300S	A-2	1.00" 25.4mm	2.96" 75.2mm	3.00" 76.2mm	2.1 lb .95 kg
8 inch	Q8-200S	A-2	1.50" 38.1mm	3.95" 100.3mm	2.00" 50.8mm	2.9 lb 1.3 kg
	Q8-300S	A-2	1.50" 38.1mm	3.95" 100.3mm	3.00" 76.2mm	4.3 lb 1.9 kg
10 inch	Q10-200S	A-2	1.50" 38.1mm	4.95" 125.7mm	2.00" 50.8mm	3.7 lb 1.7 kg
	Q10-300S	A-2	1.50" 38.1mm	4.95" 125.7mm	3.00" 76.2mm	5.6 lb 2.5 kg

*Weights are per piece

QC Jaw Turning Fixtures

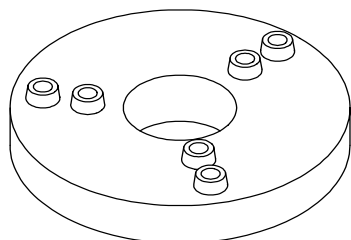

QC jaw turning fixtures mirror the locating pattern of a QC chuck. They are used to rough and/or finish blank QC top jaws off-line, maximizing your machine's production capacity.

The clamping position of the jaw turning fixture is set in the middle of the chuck's stroke. Other positions are available upon request.

Chuck	Model	Outside dia.	Thickness
4 inch	QC/JTF-4	4.125"	1.281"
		104.8mm	32.5mm
6 inch	QC/JTF-6	6.50"	1.125"
		165.1mm	28.6mm
8 inch	QC/JTF-8	7.95"	1.25
		201.9mm	31.7mm
10 inch	QC/JTF-10	9.95"	1.25
		252.7mm	31.7mm

Chuck Lubricant & Accessories

Chuck Lubricant



DTE-HH is a high performance oil formulated to provide a high level of protection from wear, with proprietary additives for superior protection against rust and resistance to oxidation.

Model	Quantity	Manufacturer
DTE-HH-02	2 oz (.06 L)	Mobil
DTE-HH-08	8 oz. (.24 L)	Mobil
DTE-HH-32	1 qt (.95 L)	Mobil
DTE-HH-128	1 ga (3.8 L)	Mobil

Grease Guns



H-1 and G-1 grease guns are compact, and are specifically designed for the grease fittings used on MicroCentric chucks.

Model	Capacity	Chuck Size
H-1	4 oz (.12 L)	3 to 6 inch and HST models
G-1	4 oz (.12 L)	8 inch and larger models

Loading Rings



Loading rings are used to set the chuck in a clamping position when machining top jaws. CR loading rings provide easy adjustment of the loading position for OD holding applications. The LR loading rings are used for ID holding applications.

Special configuration loading rings are quoted upon request.

Chuck Size	Model	Application
3 inch & HST3	CR-3	OD holding
	CR-H3	OD holding
	LR-3	ID holding
4 inch & HST4	CR-4	OD holding
	LR-4	ID holding
6 inch & HST6	CR-6	OD holding
	LR-6	ID holding
8 inch	CR-8	OD holding
	LR-8	ID holding
10 inch	CR-10	OD holding
	LR-10	ID holding



MicroCentric Corp • 25 So. Terminal Drive, Plainview, NY 11803 • USA
Tel: 516-349-7220 • Fax: 516-349-9354 • e-mail: sales@MicroCentric.com

1-800-573-1139

www.MicroCentric.com