

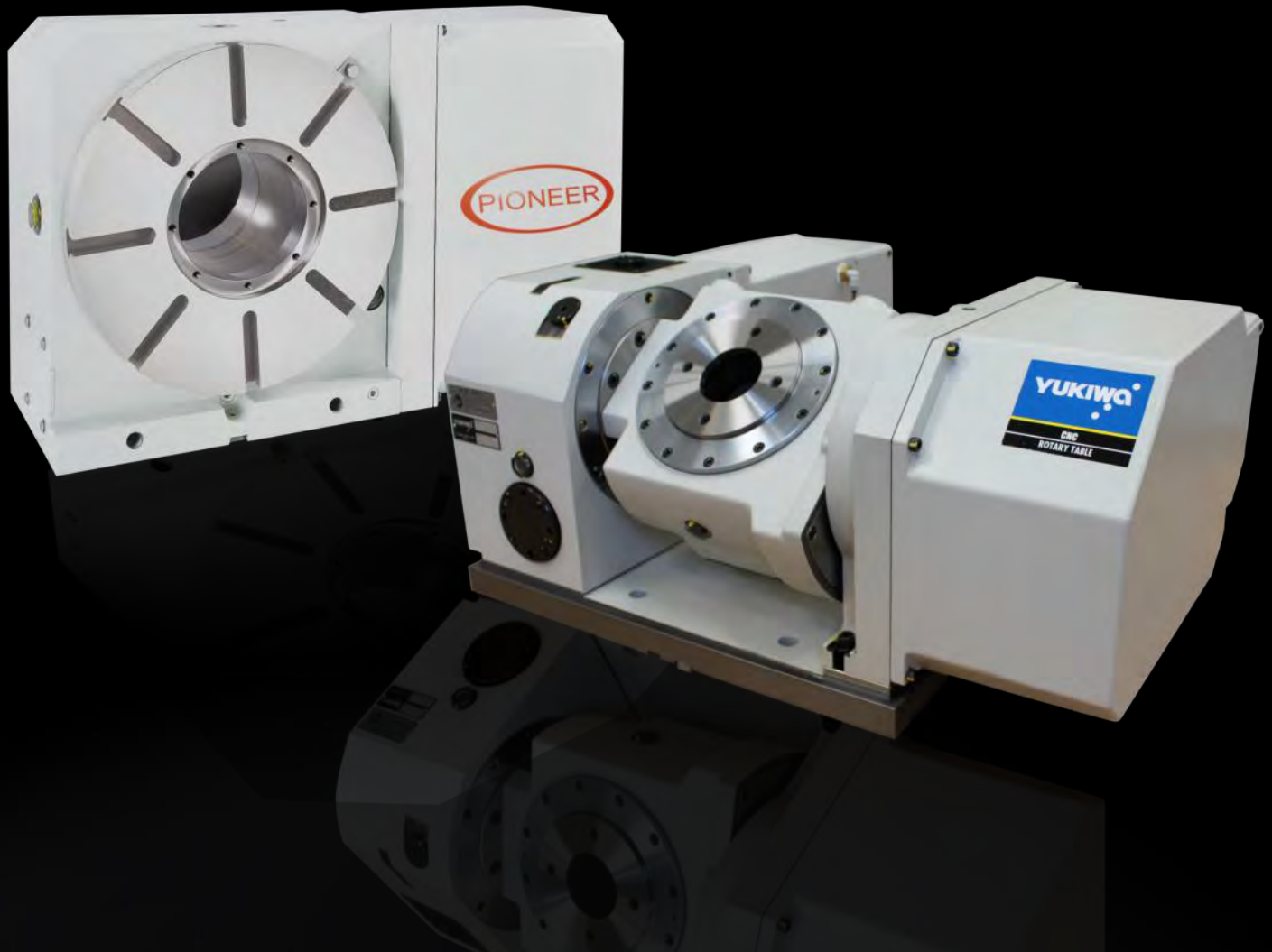

Premium Rotary Table Systems



AHB Tooling & Machinery, Inc.
Complete Metalworking Solutions
Roseville Saginaw & Jackson, MI

ISO Certified
(800) 991-4225
www.ahbinc.com
customerservice@ahbinc.com

The logo for AHB Tooling & Machinery, Inc. features the letters "AHB" in a large, stylized, white font with a red outline, set against a background of the American flag. To the right of the logo, the company name and contact information are listed in white text.



We understand the engineering intricacies that vary by industry. That's why Pioneer actively invests in research and development to enhance our already superior line of products and allow for development of individualized solutions. We are continuously working to expand our available product lines by listening to our customers while staying on top of market trends and new technology.

Since 1974, **PIONEER** has delivered world class tool and work holding products, earning a reputation built on unsurpassed service, custom solutions, and innovation.

We believe that a quality tool requires quality balance and are uncompromising in our pursuit to provide the most cost effective work holding in the market, going above and beyond the industry standard. Why? Because we know that higher accuracy results in superior outcomes, while also reducing wear and tear, and ultimately saving our customers money by extending their tool life.

Whatever your need, we have your business covered with our Premium and Standard product lines. We are passionate about providing our customers the latest, most sophisticated technology to guarantee a competitive advantage. We guarantee better performance through increased consistency and accuracy and invite you to explore the Pioneer difference.



Premium Performance Rotary Table



Heavy-duty Premium performance Table
YNCP & BNC Series
P.11



Premium Compact 5 Axis Table
TNT Series
P.21



Standard-duty performance table
JNC Series
P.15



Index Controller
AC4 & AC3
P.23



Economical EDM Rotary Table
JNC EDM
P.17



Accessories
P.27



Compact EDM Rotary Table
ERB EDM
P.19

PIONEER Premium Rotary Table



Standard Type
P.31

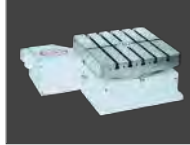

**Horizontal Rotary/Index
Center Table**
P.61



Large Size AX Rotary Table
P.35

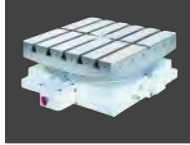

Precision Index Table
P.67



Back Mounted Motor Type
P.37



**Horizontal Machining Center
Table With Pallets**
P.69



**Roller Gear Cam Rotary
Table**
P.39



Manual Tilting Tailstocks
P.71



Multi-Spindle Type
P.41

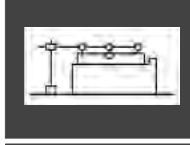

Accuracy Standards
P.75



NC Coupling Indexer
P.45

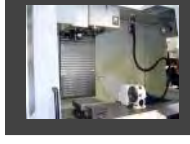

Rotary table inquiry form
P.77



Tilting Table
P.51

Power to Perform

YUKIWA and **PIONEER** put the highest level of technology and engineering together to build the CNC Rotary Tables that have the power to perform.



Durable and Rigid Dual-Lead Gear System

All YUKIWA and PIONEER tables use a combination of case hardened special alloy dual-lead screw that has larger shaft diameter, and special high tensile strength brass worm wheel ensures exceptional wear resistant and long durability for the life of the gear system.

Largest in Class Worm Wheel

Using the largest diameter in class worm wheel adds extra rigidity, smoothness and torque transfer efficiency to the gear system. It also allows deeper tooth engagement that improves surface contact by 30% compared to a conventional wheel, securing extra rigidity for heavier duty application.

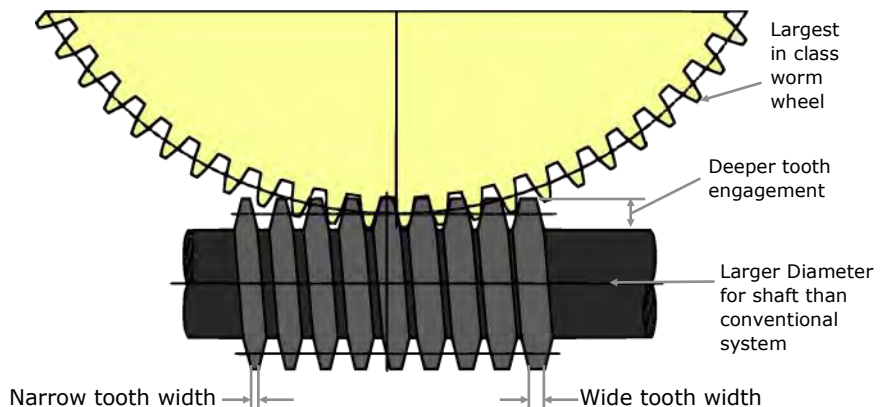

Adjustment of back lash is easy and quick!

1 million index test



Model JNC140

Weight 50 lbs

1 million Indexes = Equivalent to 1 Index / 1Minute cycle, 24/7, 1.9years worth

Backlash amount

Start 0.0005" (13 micron)

End 0.0009" (23 micron)

The Most Powerful Brake System

With Yukiwa's proprietary brake system, YNCP and TNT series deliver the most powerful brake torque, but you do not need an expensive and cumbersome hydraulic supply. Thanks to the Yukiwa's compact built-in air over hydraulic booster, simply supply standard shop air and it immediately generates strong brake torque equivalent to a hydraulic brake system. This feature makes the YUKIWA table the heaviest duty in its class.

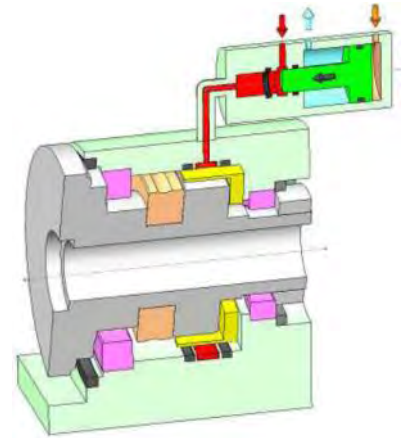

Auto Air Purge Protects You From Water Hazards

If you have ever experienced problems with the rotary tables within a couple of year or so, 90% of the problems are with electric devices like servo motors, solenoid switches and wire harness caused by cutting fluid. As high pressure coolant is getting more popular, it has become more important to select a table that has excellent water protection. Yukiwa's patented auto air purging system is the ultimate answer. It always keeps the appropriate pressure inside the cover to protect electric devices from water hazards. Auto Air Purge is standard on all Yukiwa models. Air purge is available as an option for most PIONEER models. Don't let the water down your machine any more!

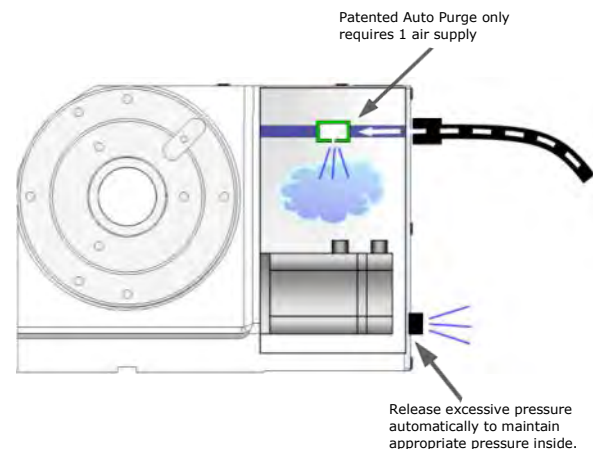

Rock Solid Design gets your job done right



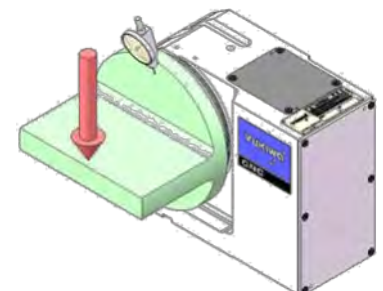
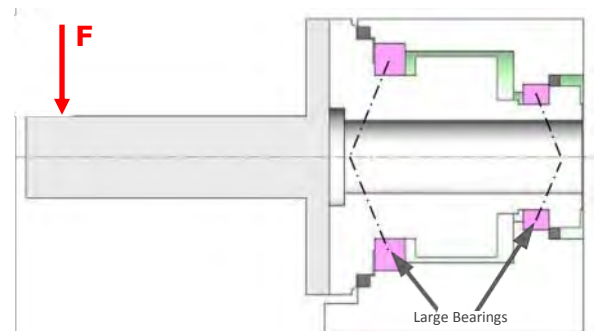

YUKIWA's True Dual Bearing System with Triple Support makes the YNCP and TNT series most robust and rock solid table in its class. Large bearings are located beneath the table face providing axial and radial support. Unlike most competitors who use only "1" bearing, YUKIWA added one more bearing at the very end of the spindle for extra support. Mated with the largest diameter spindle, YNCP and TNT series are the most robust and rock solid table. This massive construction reduces displacement from machining load by nearly 80% compared to competitors equivalent table. Whether you need to just index or simultaneous cut, remember your accuracy relies on the rigidity of the rotary table. YUKIWA rotary tables guarantees your job gets done right.



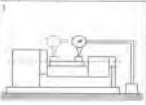

100% inspection is our policy

In order to guarantee quality for our rotary tables 100%, we believe the only way is to inspect every single rotary table before we ship. YUKIWA and PIONEER tables are subject to 100% inspection at the factory to ensure quality and performance of the rotary tables meet or exceed specifications. All YUKIWA and PIONEER table are provided with actual inspection certificate from the factory so you know your table has guaranteed quality. Further more, all YUKIWA tables are subject to test run at least 3 hours at the factory.

Tilting Rotary Table - Inspection Report					
Model	TNT170R	Manufacturing Serial No.	120		
Order					
Delivery					
Accuracy					
No.	Inspection Items	Unit	Tolerance	Actual	
1	Parallelism of Table Face to Bottom Face (Tilting Axis direction)	Over 300mm	mm	0.02	0.002
2	Roundness of Table Face (Circle location)	10mm inside from table edge	mm	0.02	0.003
3	Roundness of Table Flange Face	On Table Flange 150mm	mm	0.01	0.004
4	Parallelism of Tilting Axis/Center Line to Bottom Face	On ϕ 300mm	mm	0.03	0.006
5	Indicating Accuracy of table	Accumulated Pitch Error	"	30	10
6	Indicating Accuracy of Tilting Axis	"10" \pm 20" Accumulated Pitch Error	"	45	15

		
	Indicating Accuracy to be measured with Optical Instrument.	
Indicating Accuracy to be measured with Grating Instrument.		

YUKIWA SEIKO INC.   

TNT170-50検査報告書 01 03.03.25

Top notch inspection equipment ensures accuracy

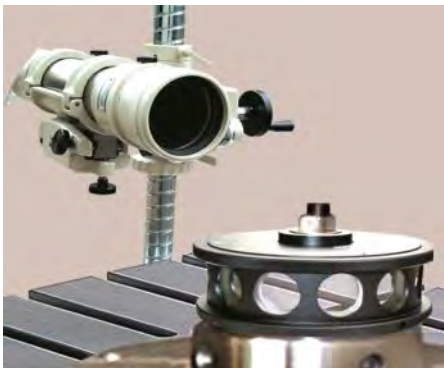

Nikon autocollimator

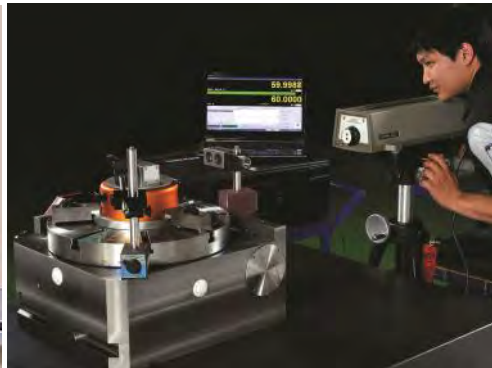

HP optical angle encoder

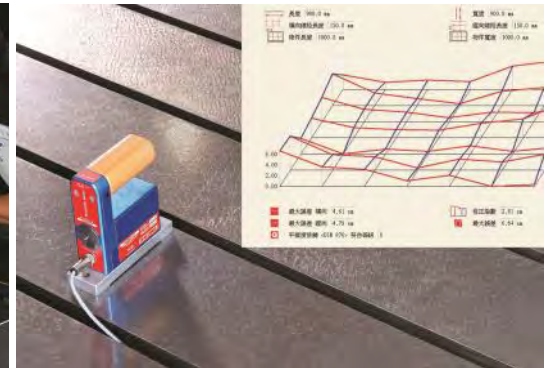

Wyler electric level tester

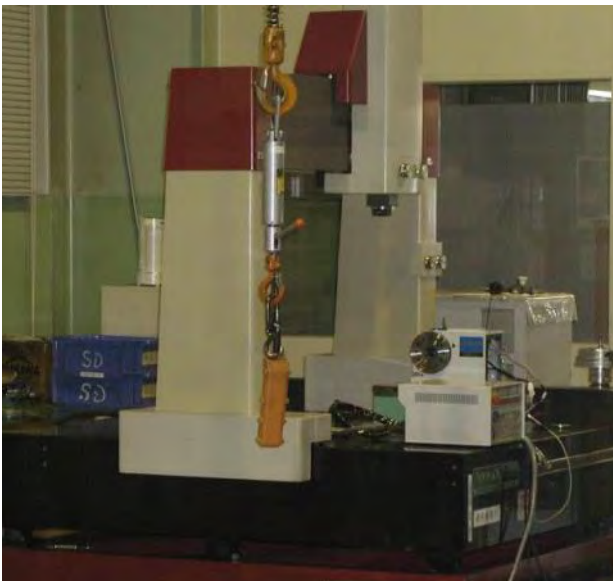

Large CMM for after finished table inspection



ZEISS CMM for components inspection

State of the art factory equipment makes

YUKIWA and PIONEER with the state of the art factory equipment produce the widest range of CNC rotary table products such as: 5" most affordable table to up to 80" super large table, compact 5 axis table for BT30 application to up to 800mm 5 axis trunnion table, industry standard worm gear system, roller gear cam, Direct Drive system, and many more. From our standard rotary tables to special tailor made rotary tables, we have the ability to quote, build and service. This feature makes us the "one stop shop" for all your rotary table needs.

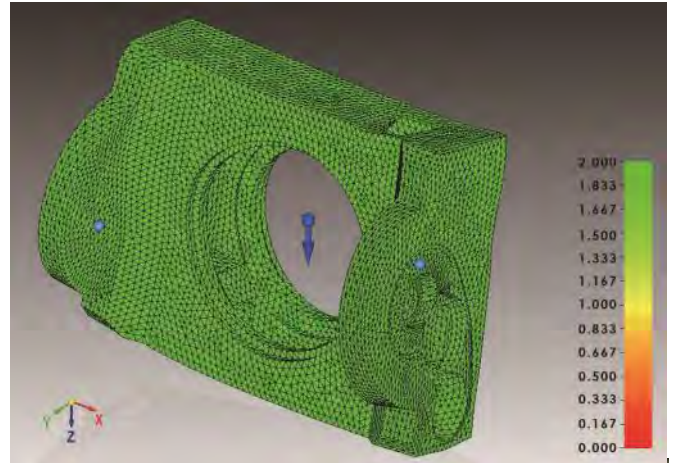



PIONEER brings an Installation and Service department
SECOND TO NONE

PIONEER brings an Installation and Service department second to none, with over 20 years experience in full rotary table 4th and 5th Axis installations as well as repair and service on many popular brands.

- Full Turnkey Installations on many Fanuc based controls including Fanuc 0i, 16i, 18i, 21i series and more.
- Guaranteed Compatibility - We only install OEM Motors & Controllers to guarantee 100% compatibility with the machine control.

Installation includes:

- Drive (Amplifier) Installation
- Table Installation
- Parameter Updates
- External Cable Installation
- Cable Set
- Communication Cables
- Fiber Optic Cables
- Bulkhead Cable Set

Rotary Tables or Indexer - Which one do you need?

- **Indexer:** using a secondary controller for part positioning. While simultaneous or contour milling is not possible with indexer, advantage of indexer is you can move the indexer and controller from machine to machine easily when you need it on the other machine. Indexer option only needs one M-code function to send FIN signal to the secondary controller. Most machines these days come with M-code function so check your local machine dealer or builder if the machine has the M-code function.
- **Integrated Rotary Table:** which is wired directly to the machine control and functions as an additional true axis of the machine. This configuration can be used for positioning and simultaneous cutting. While interfacing is a lot more complicated than indexer (we can do that for you!), the benefits and options are dramatically improved. Integrated Rotary Table is the only option that enables you to perform true 4th and 5th axis work on your machine.

Machine and control capability

Even though you want to install 4th & 5th axis rotary table if the machine control is capable of only 4 simultaneous axis, it will only be 4th axis and you will need separate control for your 5th axis. It is also possible that your machine control is capable of 5 simultaneous axis but your machine does not have 5th axis software preinstalled at the factory. If you are not sure, we can help you find your machine and control capability. With over 15 years of installation experience PIONEER knows many different machines and controls.

What machine and control brand can PIONEER do the installation?

With over 15 years of experience we can install on most Fanuc based control machines including Mori Seiki. Installation on Yaskawa and Mitsubishi control can be available, too. We just need to know your machine make, model, year and control model, or simplest and best way is send us the machine data sheet then we can advise you if we can offer installation immediately.

Note that availability of installation on custom controls or proprietary control like Haas, Mazak, Okuma etc are subject to availability of information and support from the machine builder and/or dealer.

Premium Performance Rotary Tables





Heavy-duty Premium performance Table

YNCP Series

P.11



Heavy-duty Premium performance Table

BNC Series

P.13



Standard-duty performance table

JNC Series

P.15



Economical EDM Rotary Table

JNC EDM

P.17

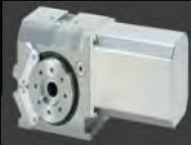

Compact EDM Rotary Table

ERB EDM

P.19



Premium Compact 5 Axis Table

TNT Series

P.21



Index Controller

AC4 & AC3

P.23







Accessories

P. 27



- Strongest brake torque in class with “Built In” air over hydraulic booster
- Heaviest duty design in class:
 - True Dual Bearing design with nose & tail bearing spindle for “Best in Class” Rigidity
 - Largest diameter bearing, worm wheel and spindle diameter for heavier duty milling
 - Solid one piece face plate and spindle construction
- Exceptional water protection with patented Auto Air Purging System
- Available as :
 - Integrated 4th axis
 - Indexer with programmable YUKIWA AC4 control box
 - Left hand configurations
 - Super high resolution with optional rotary scale

Model	YNCP170R/L		YNCP200R/L		YNCP250R/L	
Table Diameter	170mm	6.69"	200mm	7.87"	250mm	9.84"
Center Height	135mm	5.31"	160mm	6.30"	200mm	7.87"
Center Pilot Diameter	60mm H7 x 10mm	2.36" H7 x 0.39"	70mm x H7	2.76" H7 x 0.39"	90mm H7 x 10mm	3.54" H7 x 0.39"
Center Hole	45mm	1.77"	56mm	2.20"	72mm	2.83"
Guide Block Width	14mm h7	0.55" h7	18mm h7	0.71" h7	18mm h7	0.71" h7
FANUC servo motor	aiF1/2		aiF4/8		aiF8	
Max. RPM	33.3		33.3		33.3	
Gear Ratio	1:90		1:90		1:90	
Indexing Accuracy arc sec.	± 12.5		± 10		± 10	
Net Weight without motors	43kg	95lbs	69kg	152lbs	114kg	251lbs
Clamp System	Pneumatic - Air Over Hydraulic					
Clamp Torque (at 72 psi)	550Nm	406 ft-lbs	850Nm	627 ft-lbs	1,050Nm	774 ft-lbs
Vertical Workload Limit (Inertia) 	70kg (0.25kgm ²)	154lbs (0.25kgm ²)	100kg (0.5kgm ²)	220lbs (0.5kgm ²)	125kg (1.0kgm ²)	275lbs (1.0kgm ²)
Horizontal Workload Limit (Inertia) 	140kg (0.5kgm ²)	309lbs (0.5kgm ²)	200kg (1.0kgm ²)	440lbs (1.0kgm ²)	250kg (2.0kgm ²)	550lbs (2.0kgm ²)
Horizontal Load Limit 	9,000N	2,023lbf	10,000N	2,248lbf	11,000N	2,473lbf
Circumference Load Force 	550Nm	406 ft-lbs	850Nm	627 ft-lbs	1050Nm	774 ft-lbs
Vertical Load Limit 	4,000N	900lbf	6,000N	1,350lbf	7,000N	1574lbf

* All specifications can be modified according to customer's requirement

YNCP170R

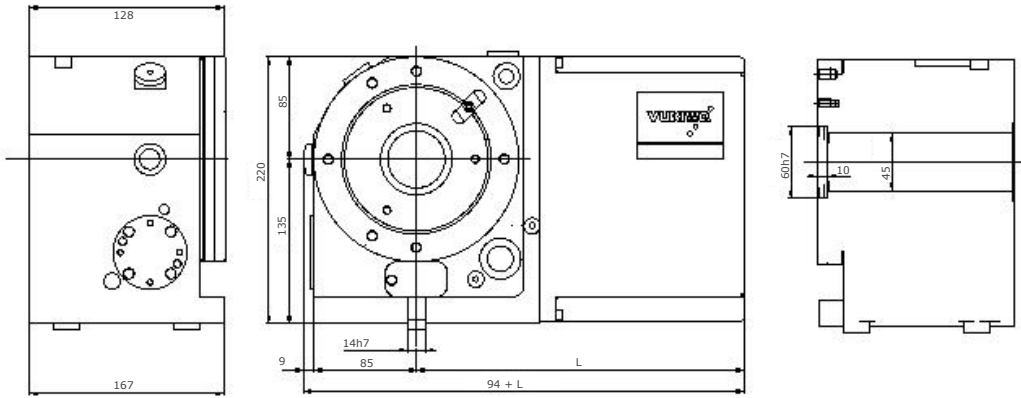

YNCP200R

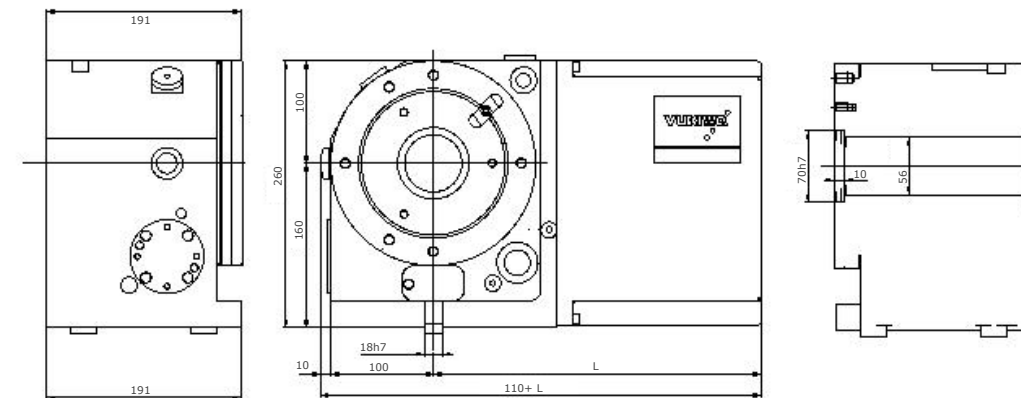



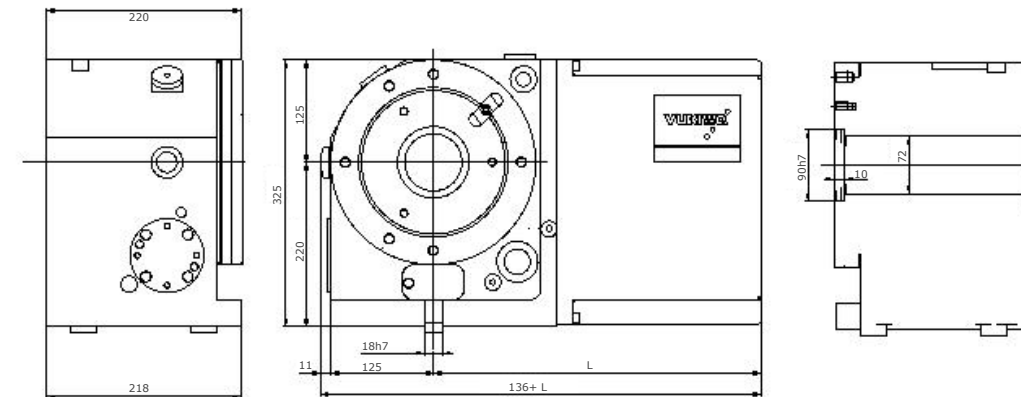

YNCP250R





- Strongest brake torque in class with “Built In” air over hydraulic booster
- Heaviest duty design in class:
 - True Dual Bearing design with nose & tail bearing spindle for “Best in Class” Rigidity
 - Largest diameter bearing, worm wheel and spindle diameter for heavier duty milling
 - Solid one piece face plate and spindle construction
- Big Bore Design – largest in class
- Exceptional water protection with patented Auto Air Purging System
- Available as :
 - o Integrated 4th axis
 - o Indexer with programmable YUKIWA AC3 control box
 - o Left hand configurations
 - o Super high resolution with optional rotary scale

Model	BNC320R	
Table Dia meter	320mm	12.6"
Center Height	230mm	9.05"
Center Pilot Diameter	170mm H7	6.69" H7
Center Hole	160mm	6.30"
Guide Block Width	18mm h7	0.71" h7
FANUC servo motor	αiF 8	
Max. RPM	22.2	
Gear Ratio	1:90	
Indexing Accuracy arc sec.	± 10 seconds	
Net Weight without motors	175kg	385 ft-lbs
Pneu. Clamp Torque (at 72 psi)	3,000Nm	2,212 ft-lbs
Vertical Workload Limit (Inertia)	 200kg (2.50kgm ²)	440lbs (2.50kgm ²)
Horizontal Workload Limit (Inertia)	 400kg (5.0kgm ²)	880lbs (5.0kgm ²)
Horizontal Load Limit	 18,000 N	4,046lbf
Circumference Load Force	 3,000Nm	2,213 ft-lbs
Vertical Load Limit	 11,000 N	2,473lbf



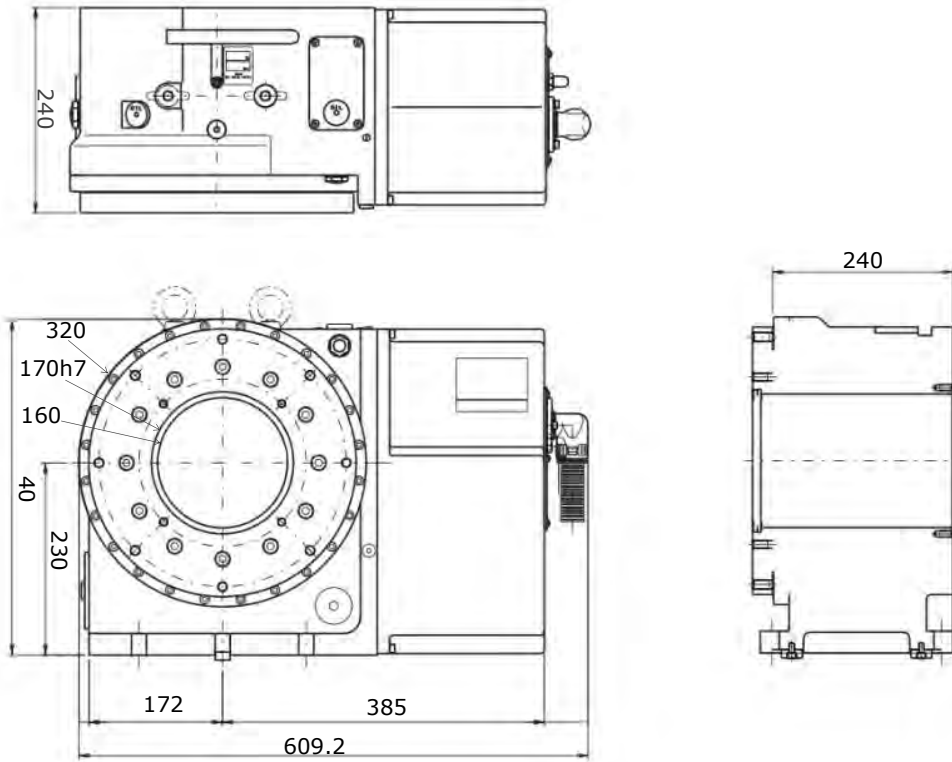

* All specifications can be modified according to customer's requirement

BNC320R





- Affordable Quality Japanese manufactured rotary table
- Compact Design suitable for small machines.
- Accurate indexing & high durability worm gearing system and solid once piece face plate and spindle design
- Exceptional water protection with patented Auto Air Purging System
 - o Protects unit against high pressure coolant
 - o Suitable for grinding, graphite and EDM application
- Available as :
 - o Integrated 4th axis
 - o Indexer with programmable YUKIWA AC4 control box
 - o Left hand configurations
 - o Super high resolution with optional rotary scale

Model	JNC140R/L		JNC170R/L		JNC200R/L		JNC250R/L	
Table Diameter	140mm	5.51"	170mm	6.69"	200mm	7.87"	250mm	9.84"
Center Height	110mm	4.33"	135mm	5.31"	160mm	6.30"	200mm	7.87"
Center Pilot Diameter	40mm H7 x 10mm	1.57" H7 x 0.39"	60mm H7 x 10mm	2.36" H7 x 0.39"	70mm x H7	2.76" H7 x 0.39"	90mm H7 x 10mm	3.54" H7 x 0.39"
Center Hole Diameter	28mm	1.10"	45mm	1.77"	56mm	2.20"	72mm	2.83"
Guide Block Width	14mm h7	0.55" h7	14mm h7	0.55" h7	18mm h7	0.71" h7	18mm h7	0.71" h7
FANUC servo motor	Bis1		aiF1/2		aiF2		aiF4/8	
Max. RPM	41.6		33.3		33.3		33.3	
Gear Ratio	1:72		1:90		1:90		1:90	
Indexing Accuracy arc sec.	± 20 seconds		± 20 seconds		± 20 seconds		± 15 seconds	
Net Weight without motors	27kg	60lbs	38kg	84lbs	58kg	128lbs	86kg	190lbs
Pneu. Clamp Torque (at 72 psi)	120Nm	89ft-lbs	230Nm	170ft-lbs	450Nm	332ft-lbs	650Nm	480ft-lbs
Vertical Workload Limit (Inertia) 	50kg (0.125kgm ²)	110lbs (0.125kgm ²)	70kg (0.25kgm ²)	154lbs (0.25kgm ²)	100kg (0.5kgm ²)	220lbs (0.5kgm ²)	125kg (1.0kgm ²)	275lbs (1.0kgm ²)
Horizontal Workload Limit (Inertia) 	100kg (0.25kgm ²)	220lbs (0.25kgm ²)	140kg (0.5kgm ²)	309lbs (0.5kgm ²)	200kg (1.0kgm ²)	440lbs (1.0kgm ²)	250kg (2.0kgm ²)	550lbs (2.0kgm ²)
Horizontal Load Limit 	4,000N	900lbf	5,000N	1,124lbf	7,000N	1,574lbf	8,000N	1,800lbf
Circumference Load Force 	120Nm	89ft-lbs	230Nm	170ft-lbs	450Nm	332ft-lbs	650Nm	480ft-lbs
Vertical Load Limit 	2,000N	450lbf	3,000N	675lbf	4,000N	900lbf	5,000N	1,124lbf

* All specifications can be modified according to customer's requirement

JNC 140R

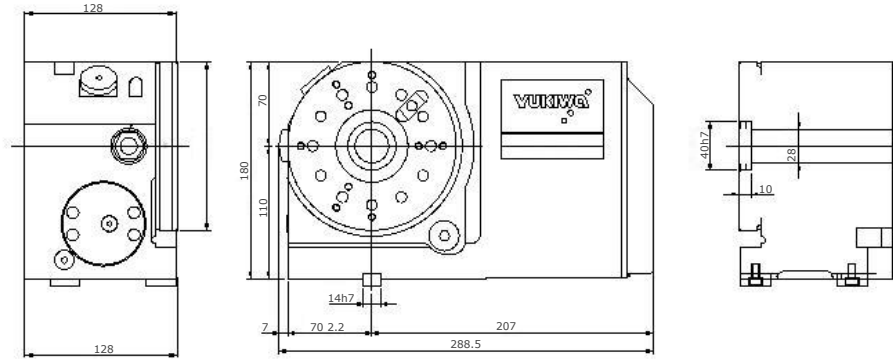

JNC170R

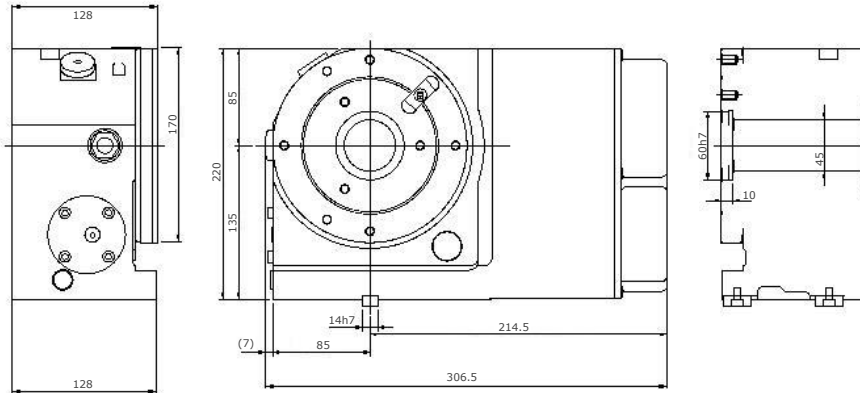

JNC200R

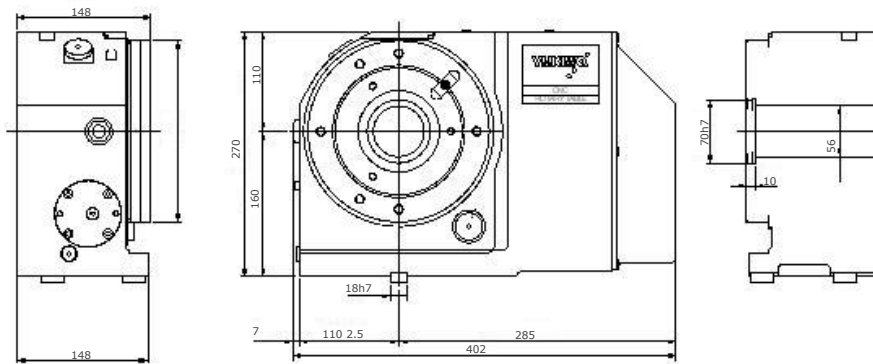



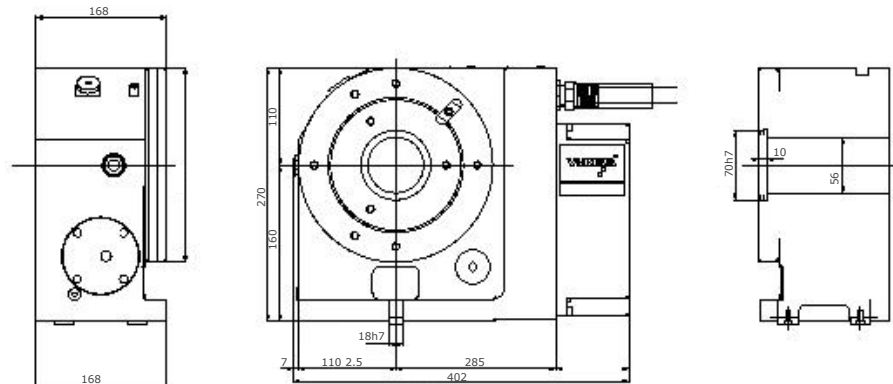

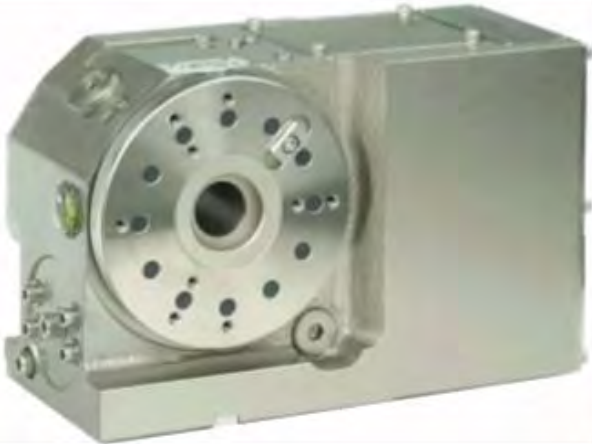
JNC 250R





- Most affordable EDM rotary and indexing solution
- Submersible protection w/ Standard Auto Air Purging System (PAT)
- Optional stainless steel face plate with commutator block
- Optional nickel plating for corrosion protection
- Super high resolution indexing accuracy w/optional rotary scale
- Vertical installation standard – Optional horizontal available
- Available as :
 - o Integrated 4th axis
 - o Indexer with programmable YUKIWA AC4 control box

Model	JNC140R-EDM		JNC170R-EDM		JNC200R-EDM		JNC250R-EDM	
Table Diameter	140mm	5.51"	170mm	6.69"	200mm	7.87"	250mm	9.84"
Center Height	110mm	4.33"	135mm	5.31"	160mm	6.30"	200mm	7.87"
Center Pilot Diameter	40mm H7 x 10mm	1.57" H7 x 0.39"	60mm H7 x 10mm	2.36" H7 x 0.39"	70mm x H7	2.76" H7 x 0.39"	90mm H7 x 10mm	3.54" H7 x 0.39"
Center Hole Diameter	28mm	1.10"	45mm	1.77"	56mm	2.20"	72mm	2.83"
Guide Block Width	14mm h7	0.55" h7	14mm h7	0.55" h7	18mm h7	0.71" h7	18mm h7	0.71" h7
FANUC servo motor	βis1		αiF1/2		αiF2		αiF4/8	
Max. RPM	41.6		33.3		33.3		33.3	
Gear Ratio	1:72		1:90		1:90		1:90	
Indexing Accuracy arc sec.	± 20 seconds		± 20 seconds		± 20 seconds		± 15 seconds	
Net Weight without motors	27kg	60lbs	38kg	84lbs	58kg	128lbs	86kg	190lbs
Pneu. Clamp Torque (at 72 psi)	120Nm	89ft-lbs	230Nm	170ft-lbs	450Nm	332ft-lbs	650Nm	480ft-lbs
Vertical Weight Limit (Inertia)	 50kg (0.125kgm ²)	110lbs (0.125kgm ²)	70kg (0.25kgm ²)	154lbs (0.25kgm ²)	100kg (0.5kgm ²)	220lbs (0.5kgm ²)	125kg (1.0kgm ²)	275lbs (1.0kgm ²)
Horizontal Weight Limit (Inertia)	 100kg (0.25kgm ²)	220lbs (0.25kgm ²)	140kg (0.5kgm ²)	309lbs (0.5kgm ²)	200kg (1.0kgm ²)	440lbs (1.0kgm ²)	250kg (2.0kgm ²)	550lbs (2.0kgm ²)
Horizontal Load Limit	 4,000N	900lbf	5,000N	1,124lbf	7,000N	1,574lbf	8,000N	1,800lbf
Circumference Load Force	 120Nm	89ft-lbs	230Nm	170ft-lbs	450Nm	332ft-lbs	650Nm	480ft-lbs
Vertical Load Limit	 2,000N	450lbf	3,000N	675lbf	4,000N	900lbf	5,000N	1,124lbf

* All specifications can be modified according to customer's requirement

JNC 140R-EDM

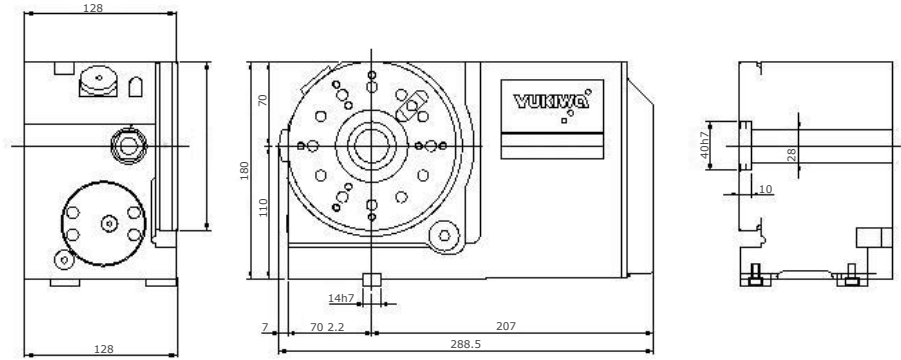

JNC170R-EDM

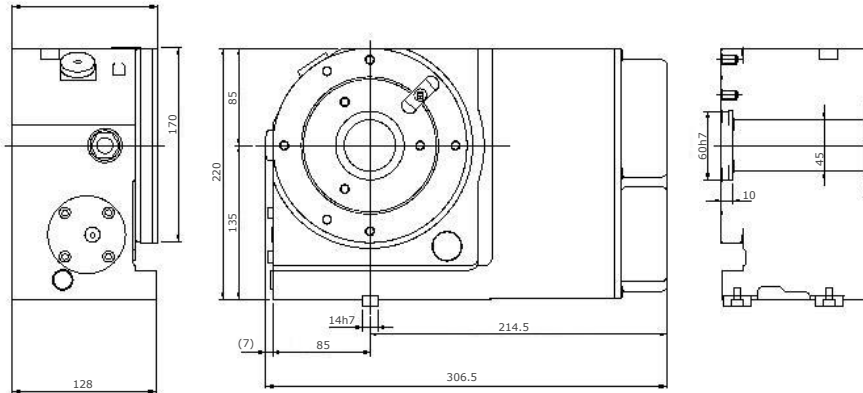

JNC200R-EDM

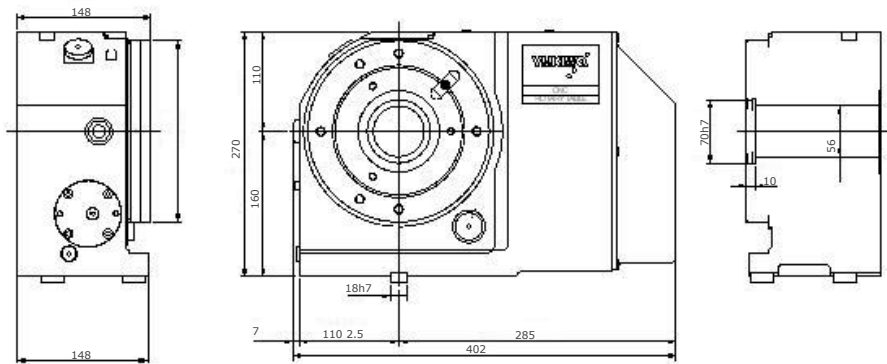

JNC 250R-EDM

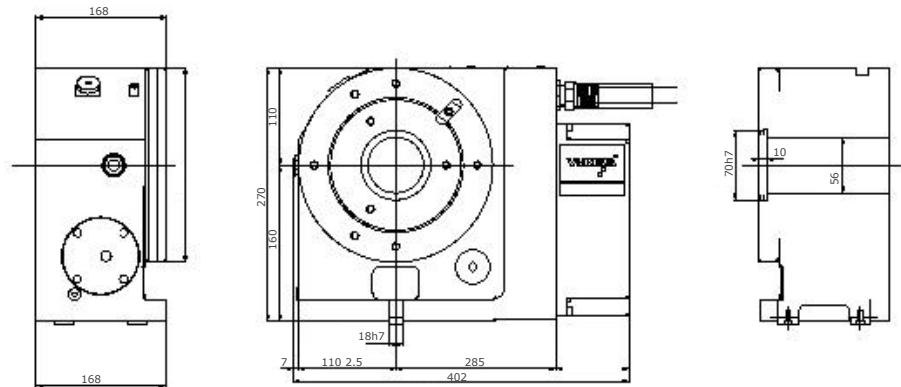



- Stainless steel body for EDM
- Low weight and compact size: 149mm of height from bottom face (at vertical position)
- Low Height : Table Diameter Φ 90mm. Center height: 65mm
- Fully submersible with water protection with sealed structure and patented Auto Air Purging
- Super high resolution indexing accuracy w/optional rotary scale
- Available as
 - o Integrated additional axis
 - o Indexer with programmable YUKIWA AC4 control box

Model	ERB90	
Table Diameter	90mm	3.54"
Center Height	65mm	2.56"
Center Pilot Diameter	40mm H7 x 10mm	1.57" H7 x 0.39"
Center Hole	21mm	0.83"
FANUC servo motor	B is0.5/iS1	
Max. RPM	10	
Gear Ratio	1:60	
Indexing Accuracy arc sec.	± 20 seconds	
Net Weight without motors	19.5kg	43lbs

* All specifications can be modified according to customer's requirement

ERB90-EDM

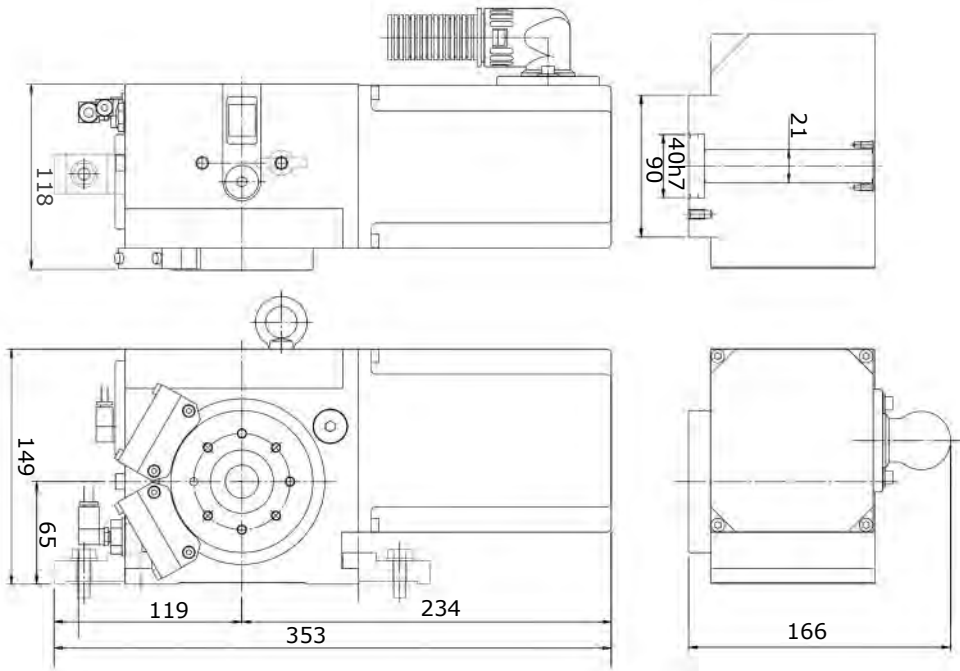



- Most compact design in class to fit small machines
- Largest machine-able work area in class
- Strongest brake torque in class with "Built In" air over hydraulic booster
- Heaviest duty design in class:
 - True Dual Bearing design with nose & tail bearing spindle for "Best in Class" Rigidity
 - Largest diameter bearing, worm wheel and spindle diameter for heavier duty milling
- Exceptional water protection with patented Auto Air Purging System
- Available as :
 - Integrated 5th axis
 - Integrated 4th axis + programmable Yukiwa AC4 controller on tilt axis
 - Indexer with programmable YUKIWA AC4 control boxes
 - Left hand configurations (TNT170 only)
 - Super high resolution with optional rotary scale

Model	TNT100L				TNT170 R/L			
	Rotating Axis		Tilting Axis		Rotating Axis		Tilting Axis	
Spindle Diameter	100mm	3.94"	-		120mm	4.72"	-	
Table Diameter (Optional)	130mm	5.12"	-		170mm / 200mm	6.69" / 7.87"	-	
Table Pilot Diameter	50mm H7 X 23mm	1.97" H7 X 0.91"	-		55mm H7 X 45mm	2.17" H7 X 1.77"	-	
Center Hole	36mmx86mm Deep	1.42"x3.38" Deep	-		40mm	1.57"	-	
	28mm Thru	1.10" Thru	-					
Table Height at Vertical	180mm	7.09"	-		240mm	9.45"	-	
Tilting Axis Center Height	-		135mm	5.31"	-		180mm	7.09"
Tilting Range	-		110° to -20°		-		110° to -20°	
Guide Block Width	14mm h7 / 0.55"							
FANUC servo motor	aiF1		aiF2		aiF2		aiF2	
Max. RPM	41.6		25		41.6		25	
Gear Ratio	1:72		1:120		1:72		1:120	
Clamp System	Pneumatic (0.5-0.7 Mpa) (72-101 psi) - Air Over Hydraulic							
Clamp Torque (at 72 psi)	200Nm	148 ft-lbs	320Nm	236 ft-lbs	520Nm	384 ft-lbs	1000Nm	738 ft-lbs
Indexing Accuracy arc sec.	± 17.5		± 20		± 15		± 22.5	
Net Weight without motors	80kg	176lbs	-		138kg	304lbs	-	
Horizontal Weight Limit at 0°	30kg	66lbs	-		60kg	132lbs	-	
Vertical Weight Limit at 90°	20kg	44lbs	-		40kg	88lbs	-	
Allowable Load Limit			4,000N / 900lbf			8,000N / 1800lbf		
			200Nm / 148 ft-lb			520Nm / 384 ft-lb		
			320Nm / 236 ft-lb			1,000Nm / 738 ft-lb		

* All specifications can be modified according to customer's requirement

TNT100R

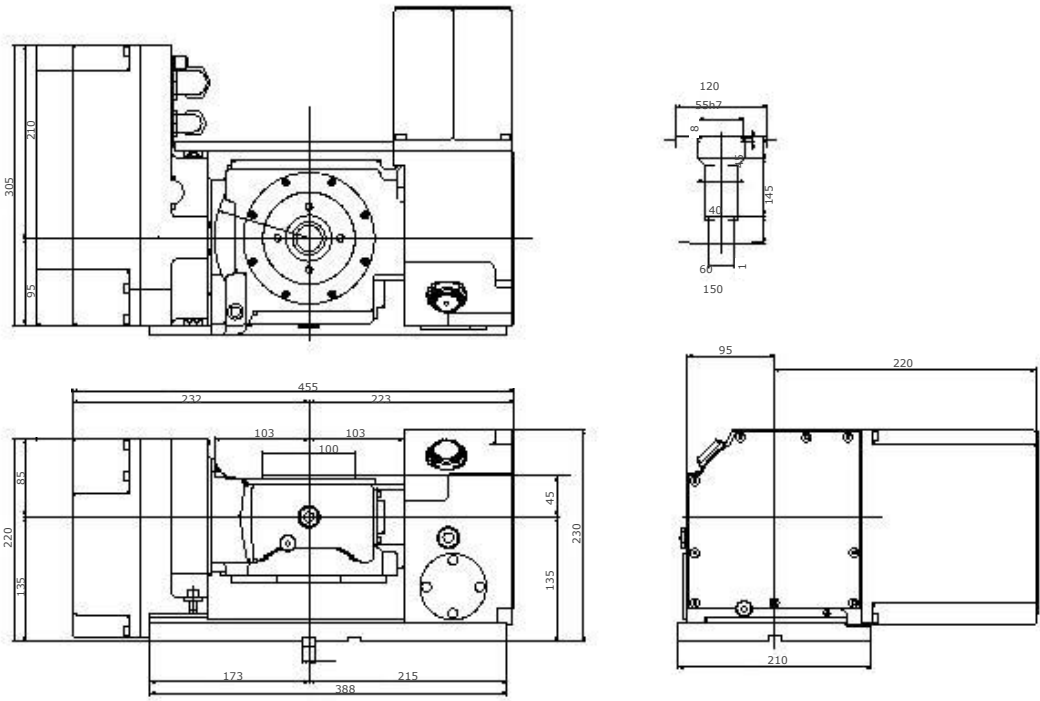

TNT170R

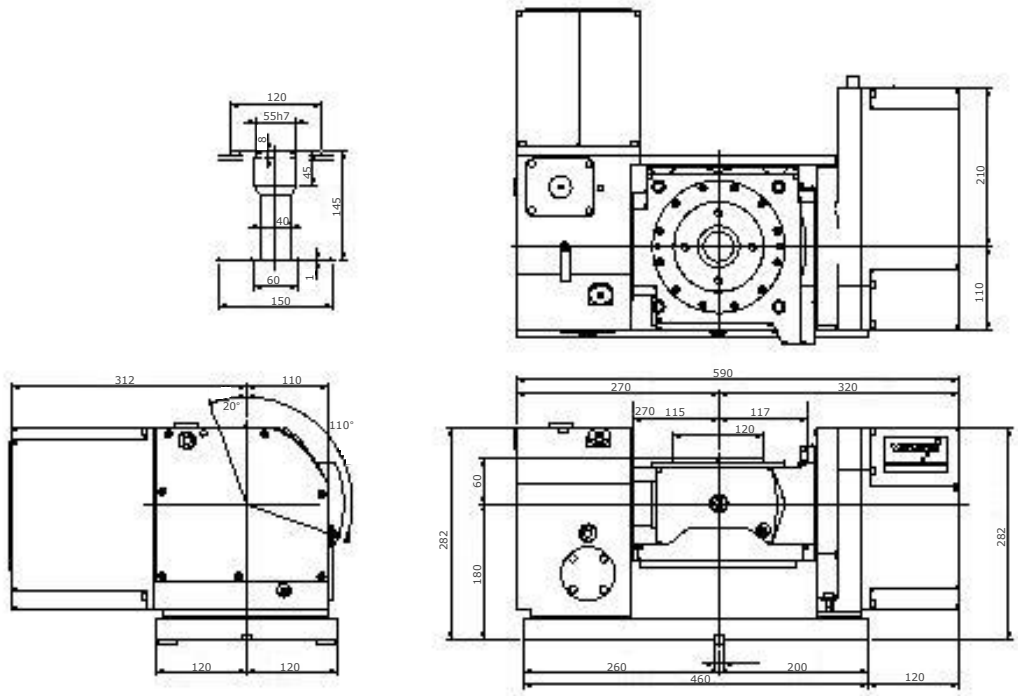



- Direct Programming up to 100 programs, total storage of 10,000 Steps
- Machine Control / Off Line Programmable w/ Machine Macro β Function & RS232 Connection
- Compact Design
- Closed Construction to prevent contamination from oil mist

Model	AC4-10	AC4-30	AC3-60	AC3-90
Voltage	Single phase AC200V~230V + 10~-15% 50/60Hz		3-phase AC200V~230V + 10%~-15% 50/60Hz	
Rated output of AC servo-motor	300W	750W	1.0kW	1.5kW
Power consumption	Max	2.2A	7A	8.7A
	Min	7.5A	15.3A	26.1A
External dimensions & Mass (including cables)	W260mm X H199mm X D228mm, 7.8kg		W260mm X H250mm X D248mm, 10.0kg	
	W10.24" X H7.83" X D8.97", 17.16lbs		W10.24" X H9.84" X D9.76", 22lbs	
Number of control axis	Rotary axis, 1 axis			
Position detection method	Incremental encoder			
Angle setting unit & Max. command angle	0.001 , ±999.999° , 999 rotations (Max rotation is continuous rotation: 5,965)			
Speed setting range	0~99999 (but limited by the reduction ratio and the motor rotation)			
JOG (manual feed) function	Selecting the rotation speed with the JOG key and the numeric keys			
Rapid override	Selecting the rapid transverse speed from 10 steps (setting 0~100% with parameter)			
Movement Mode	Auto (AUT), Manual (MAN), Return to machine origin (MZ), Return to work origin (WZ), Jog (JOG), Program edit (EDT), Parameter (PRM)			
Programming	Command method (Incremental, Absolute, Shortcut), Equal division, Sector division, Cutting feed, Multi-rotation (999 rotations), Continuous start, Interlocking start, Return to machine origin, Setting of work coordinate, Continuous block operation, Dwell, FIN, output change, Jump, Subprogram (repeating 1~999 times), Clamp valid/invalid, Running function (for trial operation)			
Program edit function	1 step/inserting deleting the steps of specified range, 1 program/deleting the programs of specified range			
Program capacity & External selection	100 programs X 100 steps, Binary mode: 16 programs, M signal mode: 100 programs			
Program/parameter memory	Non-volatile memory (Rewriting 100,000 times)			
Stroke limit	Setting with the parameter or the program (Selectable of the machine coordinate or the work coordinate)			
Diagnosis & Alarm history	Alarm number, Executing program, Current position, Shift remain, Override %, Rotation speed, Motor load torque, etc. Memorized automatically in alarming (past 69 times)			
	Number of point	8 points (DC24V, Non-contract Bipolar)		
Interlocking input	Function	Start, Return to origin, Program selection signal 0~3, Program set, interlocking		
	Number of point	4 points (DC24V, Non-contract Bipolar, Max.50mA)		
Interlocking output	Function	Block termination signal 1&2, Ready, Alarming		
	External emergency stop input	1 point (b-connection input. Interlocking cable inside), Connect the switch having contact.		
Serial interface	RS232C 1port, Dsub connector 9 pins			
Internal interlocking cable	AC3-W01		AC3-60-W01	
External interlocking cable	AC3-60-W02			

External Dimensions / Connections

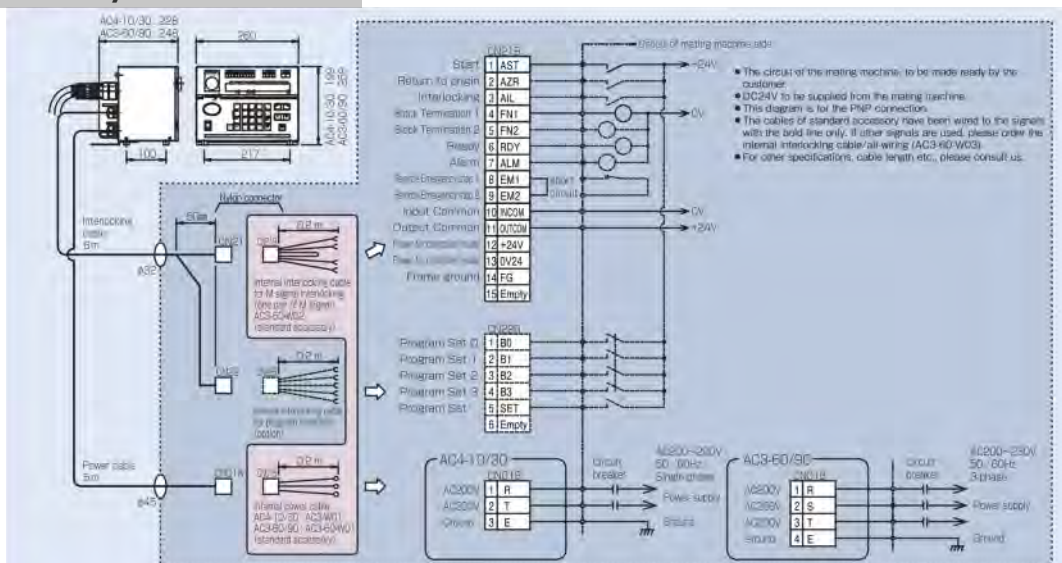

Data display

To Display program, current position parameter, diagnosis, data and etc.

P: Program numbers

N: Step numbers

ADRS: Address for program function

DATA: The first digit from the left will be indicated as follows:

Rotation direction	-	+
Shortcut	↩	↪
Effective Stroke Limit	≡	≡

W Flickering during return to work origin and will be ON when the table is on work origin.

M Flickering during return to machine origin and will be ON when the table is on machine origin.

INC ON during incremental command.

Emergency Stop Button

When pressed, the motor will be on SERVO-OFF.

For releasing, turn to right.

Interlocking

Always to show the state with interlocking signals.

FN1, FN2, and ALM are output signals, while all others are input signals.

Rotary Table

Always to show the state with signals of rotary table.

LSZ Proximity/Limit switch for zero point deceleration.

LSC Proximity/Limit switch for clamping confirmation.

CLP Flickering during the clamping and will be ON after confirmation

UNC Flickering during the unclamping and will be ON after confirmation.

Status

Always to show running status.

RUN ON during program execution.

STOP ON when stopped or when alarming appears, but flickering during the emergency stop.

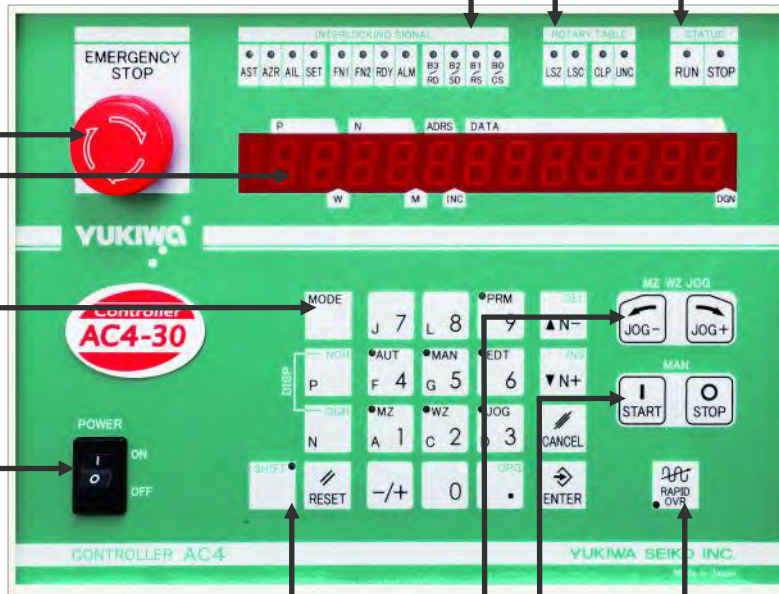

Power Switch

ON: Controller will be switched on.

MODE Numeric Key

Mode is selected by entering figures after pressing.

Selected mode will be indicated on the upper left side of the figures.

MZ Machine origin mode (return / setting)

WZ Work origin mode (return / setting)

JOG To effect one pulse feed or jog feed.

AUT Automatic operation mode interlocked with the mating machine.

MAN Operation by the controller only.

EDT Program editing. Initiating and selecting.

PRM Parameter setting mode.

For the figure key, the first pressing will enter the address of EDT mode, and the second pressing and further pressings will enter figures.

RAPID OVR Rapid Override

Flickering frequency will change per percentage and at 100%, the lamp will be OFF.

START execute one block of the program in MAN mode, and stop with **STOP**

JOG

When **JOG** key is pressed briefly in JOG mode, the table will rotate one pulse.

If the key is pressed together with a figure key, the table will rotate in the speed of the figure.

If the key is kept being pressed in ZRN mode, the table will return to origin.

When **SHIFT** is pressed, the lamp will be ON and the function will be indicated on the upper right side of each key.

Example of program

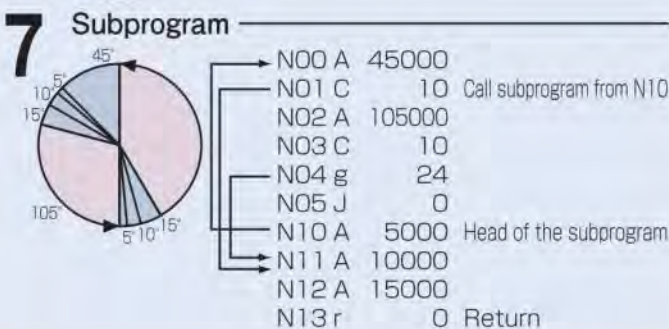
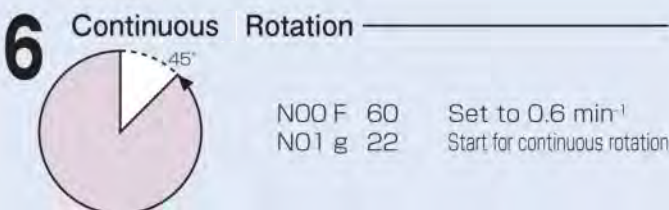
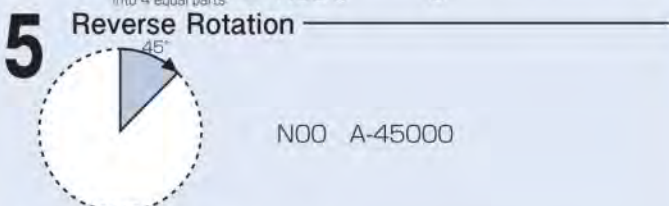
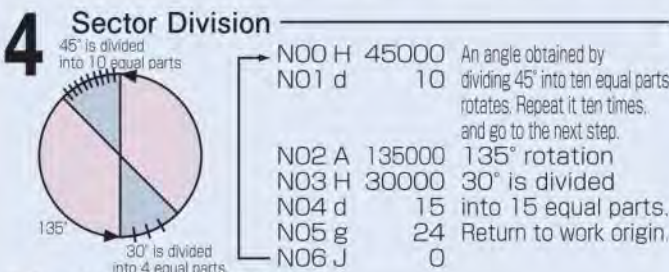
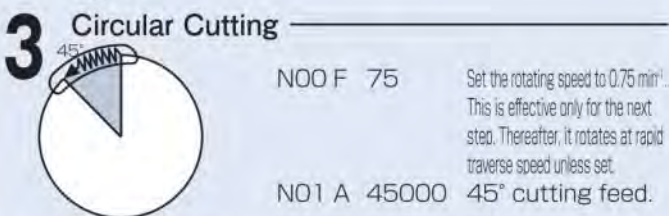
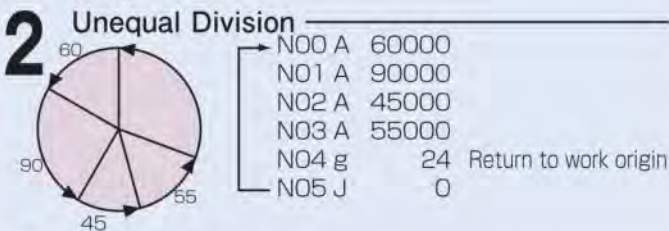
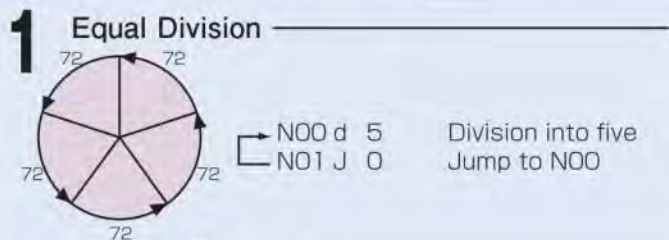

Address

A	Commands the angle rotation	(0~±999.999deg)	R
B	Equal divisions command	(±999.999deg)	R
C	Sets rotating speed	(0~±999.999deg/MIN)	B
D	Jump	(0~9999)	B
E	Subprogram	(0~9999.999)	B
F	Setting Value	[Per G code immediate before.]	B
G	Preparation function		

G Code

G30		Reverse rotation	R
G31	Return to machine origin	Normal rotation	R
G32		Automatic selection	R
G33	Interlock start		R
G34	Continuous start	Reverse rotation	R
G35		Normal rotation	R
G50	Command mode	Incremental	B
G51		Absolute ●	B
G52		Shortcut	B
G53	Clamp	Invalid	B
G54		Valid ●	B,A
G61		End ■	B,A
G62		Start ■	B
G63	Running	End	B,A
G64		Start	B
G70		Current position	B
G71		Machine coordinate	B
G72	Sector Aperture angle setting	LO~359.999(deg)	B
G73	Setting of multiple rotations	L+999	B
G81	Dwell	LO~9.999(sec)	A
G82	FIN output change	Not output	A
G83		FN2 only output	A
G84		FN1,2 output	A

●: Setting with the power source being ON and changeable by parameter.

■: Setting with the power source being ON.

R: Commanding to execute rotation

B: Commanding to immediate before R-type.

A: Commanding to immediate after R-type.

For G-code with L, the figures will be set by L-commands of preceding G-code.

Commanding to immediate before R-type.

Timing Chart

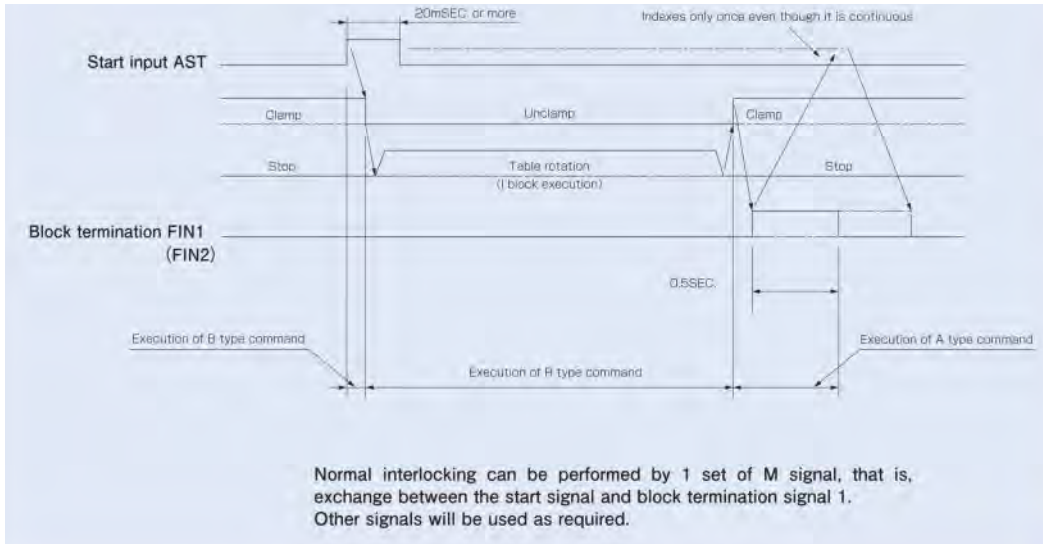

Example of interlocking signal with a machining center

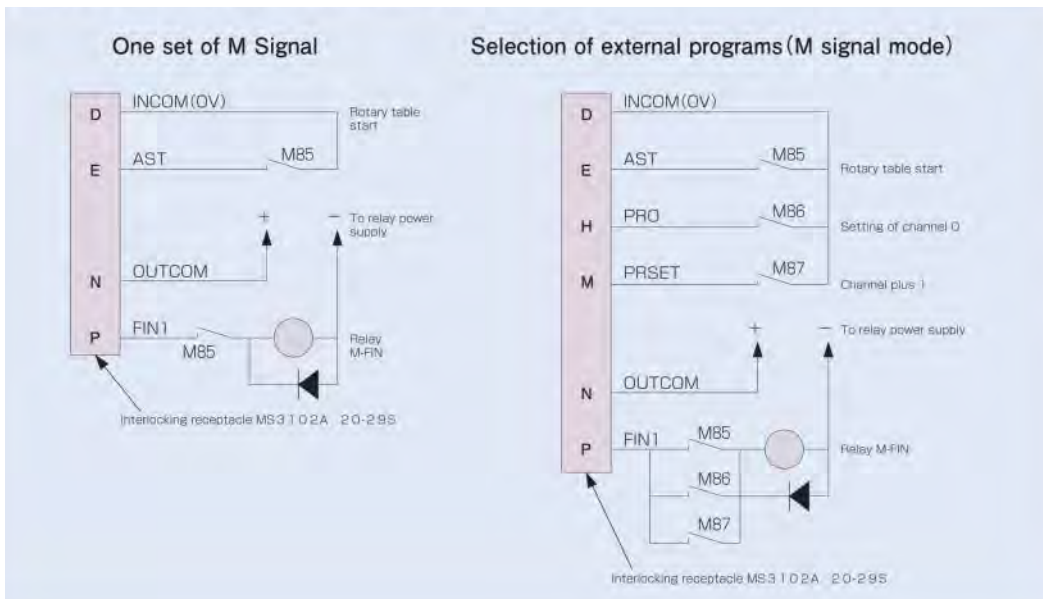

Interlocking Connection Diagram

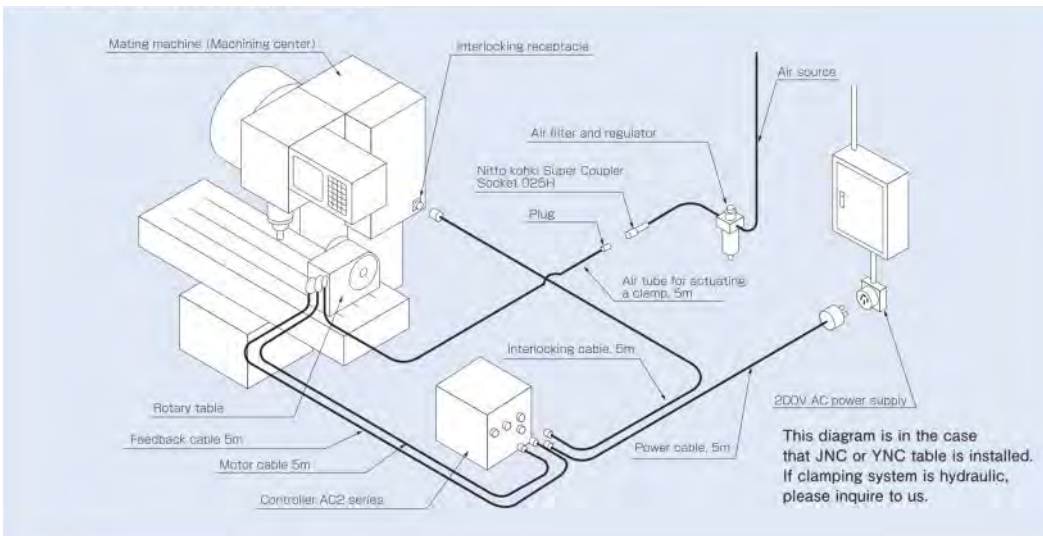

Manual Tail Stock

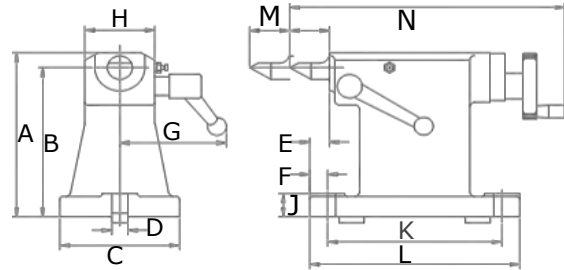

Model	Applicable Model	Center (shaft OD)	Weight	A	B	C	D	E	F	G	H	J	K	L	M	N	P
TSB110S	JNC140	25mm	8kg	126mm	110mm	110mm	14mm	10mm	22mm	88mm	50mm	20mm	160mm	190mm	20mm	25mm	205mm
		0.98"	17lbs	4.96"	4.33"	4.33"	0.55"	0.39"	0.87"	3.46"	1.97"	0.79"	6.30"	7.48"	0.79"	0.98"	8.07"
TSB135S	JNC170,YNCP170	25mm	10kg	151mm	135mm	110mm	14mm	20mm	26mm	107mm	70mm	23mm	174mm	210mm	40mm	40mm	275mm
		0.98"	22lbs	5.94"	5.31"	4.33"	0.55"	0.79"	1.02"	4.21"	2.76"	0.91"	6.85"	8.27"	1.57"	1.57"	10.83"
TSB160S	JNC200,YNCP200	25mm	11kg	176mm	160mm	120mm	18mm	20mm	26mm	107mm	70mm	25mm	174mm	210mm	40mm	40mm	275mm
		0.98"	24lbs	6.93"	6.30"	4.72"	0.71"	0.79"	1.02"	4.21"	2.76"	0.98"	6.85"	8.27"	1.57"	1.57"	10.83"
TSB200S	JNC250,YNCP250	38mm	25kg	227mm	200mm	140mm	18mm	10mm	25mm	128mm	90mm	35mm	228mm	260mm	40mm	50mm	395mm
		1.50"	55lbs	8.94"	7.87"	5.51"	0.71"	0.39"	0.98"	5.04"	3.54"	1.38"	8.98"	10.24"	1.57"	1.97"	15.55"

Pneumatic Tail Stock

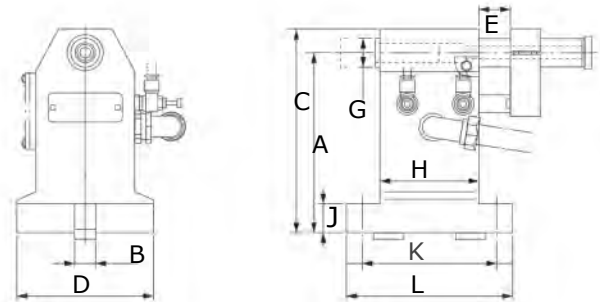

Model	Applicable Model	Shaft Thrust	Weight (kg)	ID Taper	A (Center Height)	B (h7)	C	D	E (Stroke)	F	G	H	J	K	L
TPA110	JNC140	310mm	6kg	MT2	110mm	14mm	130mm	88mm	40mm	25mm	25mm	85mm	20mm	119mm	149mm
		12.20"	13lbs		4.33"	0.55"	5.12"	3.46"	1.57"	0.98"	0.98"	3.35"	0.79"	4.69"	5.87"
TPA135	JNC170,YNCP170	310mm	7kg	MT2	135mm	14mm	155mm	88mm	40mm	25mm	25mm	85mm	20mm	119mm	149mm
		12.20"	15lbs		5.31"	0.55"	6.10"	3.46"	1.57"	0.98"	0.98"	3.35"	0.79"	4.69"	5.87"
TPA160	JNC200,YNCP200	310mm	9kg	MT2	160mm	18mm	180mm	120mm	40mm	25mm	25mm	85mm	25mm	119mm	149mm
		12.20"	19lbs		6.30"	0.71"	7.09"	4.72"	1.57"	0.98"	0.98"	3.35"	0.98"	4.69"	5.87"
TPA200	JNC250,YNCP250	490mm	12kg	MT3	200mm	18mm	225mm	120mm	40mm	32mm	32mm	89mm	25mm	123mm	153mm
		19.29"	27lbs		7.87"	0.71"	8.86"	4.72"	1.57"	1.26"	1.26"	3.50"	0.98"	4.84"	6.02"

Side Table

Features: Air Break System for additional holding power

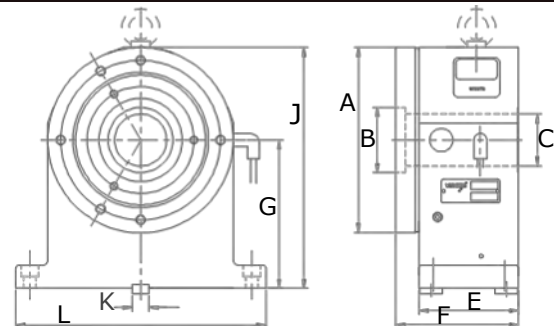
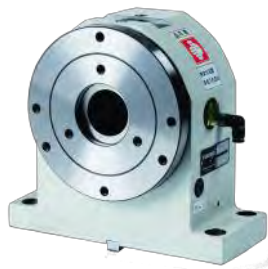

Model	Applicable Model	Clamp Torque	Weight	A (Spindle Dia)	B (Pilot)	C (Hole Thru)	E	F	G (Center Height)	J	K	L
ST135	JNC170,YNCP170	153Nm	21kg	170mm	60mm	45mm	98mm	117mm	135mm	220mm	14mm	240mm
		112.85ft-lbs	46lbs	6.69"	2.36"	1.77"	3.86"	4.60"	5.31"	8.66"	0.55"	9.45"
ST160	JNC200,YNCP200	415Nm	33kg	200mm	70mm	56mm	107mm	132mm	160mm	270mm	18mm	270mm
		306.09ft-lbs	73lbs	7.87"	2.76"	2.20"	3.86"	5.20"	6.30"	10.63"	0.71"	10.63"
ST200	JNC250,YNCP250	517Nm	58kg	250mm	90mm	72mm	124mm	151mm	200mm	325mm	18mm	320mm
		381.32ft-lbs	128lbs	9.84"	3.54"	2.83"	4.88"	5.94"	7.87"	12.80"	0.71"	12.60"

SS Series

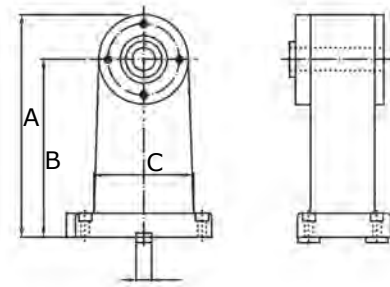

Model	Applicable Model	Center Height	Weight	A	B	C	D
SS110	JNC140	110mm	9kg	160mm	110mm	100mm	14mm
		4.33"	22lbs	6.30"	4.33"	3.94"	0.55"
SS135	JNC170,YNCP170	135mm	10kg	185mm	135mm	100mm	14mm
		5.31"	23lbs	7.28"	5.31"	3.94"	0.55"
SS160	JNC200,YNCP200	160mm	11kg	210mm	160mm	100mm	18mm
		6.30"	24lbs	8.27"	6.30"	3.94"	0.71"
SS200	JNC250,YNCP250	200mm	12mm	250mm	200mm	110mm	18mm
		7.87"	27lbs	9.84"	7.87"	4.33"	0.71"

Outside mount type rotary joint

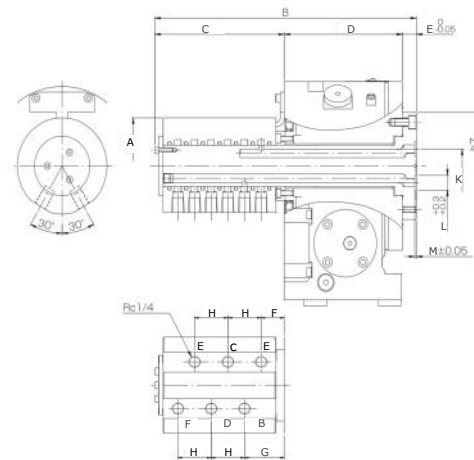

Model		Number of ports	Applicable Pressure (Mpa)	A	B	C	D	E	F	G	H	J	K	L	M	N	P	Q
JNC 140 L/R	-SJ4L	4	3.5	87mm	229mm	91mm	128mm	10mm	20mm	36mm	32mm	95mm	24mm	12mm	1.4mm	6-M6X10 (P.C.D.118)	3-M6X10 (P.C.D.78)	-
				3.43"	9.02"	3.58"	5.04"	0.39"	0.79"	1.42"	1.26"	3.74"	0.94"	0.47"	0.06"			
JNC (H) 170 L/R	-SJ6L	6	3.5	97mm	283mm	140mm	128mm	15mm	25mm	43mm	36mm	108mm	34mm	15mm	1.8mm	6-M8X12 (P.C.D.150)	3-M6X15 (P.C.D.88)	14h7 6mm
				3.82"	11.14"	5.51"	5.04"	0.59"	0.98"	1.69"	1.42"	4.25"	1.34"	0.59"	0.07"			
	-SJ6H	6	7.0	105mm	283mm	140mm	128mm	15mm	25mm	43mm	36mm	108mm	34mm	15mm	1.8mm			
JNC (H) 200 L/R	-SJ6L	6	3.5	97mm	303mm	140mm	148mm	15mm	25mm	43mm	36mm	130mm	34mm	15mm	1.8mm	6-M10X12 (P.C.D.172)	3-M8X15 (P.C.D.115)	
				3.82"	11.93"	5.51"	5.83"	0.59"	0.98"	1.69"	1.42"	5.12"	1.34"	0.59"	0.07"			
	-SJ6H	6	7.0	105mm	303mm	140mm	148mm	15mm	25mm	43mm	36mm	130mm	34mm	15mm	1.8mm			
JNC (H) 250 L/R	-SJ6L	6	3.5	122mm	358mm	140mm	168mm	15mm	32mm	54mm	44mm	153mm	39mm	15mm	1.8mm	6-M10X17 (P.C.D.210)	3-M10X15 (P.C.D.130)	
				4.80"	14.09"	5.51"	6.61"	0.59"	1.26"	2.13"	1.74"	6.02"	1.54"	0.59"	0.07"			
YNC (P) 170 L/R	-SJ6L	6	3.5	97mm	323mm	175mm	168mm	15mm	25mm	43mm	36mm	108mm	34mm	15mm	1.8mm	6-M8X12 (P.C.D.150)	3-M6X15 (P.C.D.88)	
				3.82"	12.72"	6.89"	6.61"	0.59"	0.98"	1.69"	1.42"	4.25"	1.34"	0.59"	0.07"			
	-SJ6H	6	7.0	105mm	323mm	175mm	168mm	15mm	25mm	43mm	36mm	108mm	34mm	15mm	1.8mm			
YNC (P) 200 L/R	-SJ6L	6	3.5	97mm	347mm	140mm	192mm	15mm	25mm	43mm	36mm	130mm	34mm	15mm	1.8mm	6-M10X12 (P.C.D.172)	3-M8X15 (P.C.D.115)	
				3.82"	13.66"	5.51"	7.56"	0.59"	0.98"	1.69"	1.42"	5.12"	1.34"	0.59"	0.07"			
	-SJ6H	6	7.0	105mm	347mm	140mm	192mm	15mm	25mm	43mm	36mm	130mm	34mm	15mm	1.8mm			
YNC (P) 250 L/R	-SJ6L	6	3.5	122mm	410mm	175mm	220mm	15mm	32mm	54mm	44mm	153mm	39mm	15mm	1.8mm	6-M10X17 (P.C.D.210)	3-M10X15 (P.C.D.130)	
				4.80"	16.14"	6.89"	8.66"	0.59"	1.26"	2.13"	1.74"	6.02"	1.54"	0.59"	0.07"			

PIONEER Premium Rotary Tables





Standard Type
P.31



Trunnion Models
P.55



**Large Size AX
Rotary Table**
P.35



**Manual Tilting
Rotary Table**
P.57

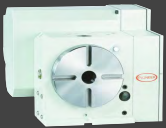

**Back Mounted
Motor Type**
P.37

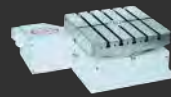

**Horizontal Rotary/
Index Center Table**
P.61



**Roller Gear Cam
Rotary Table**
P.39



**Precision Index
Table**
P.67



Multi-Spindle Type
P.41



**Horizontal Machining
Center Table With Pallets**
P.69



**NC Coupling
Indexer**
P.45



**Manual Tilting
Tailstocks**
P.71



Tilting Table
P.51





- Combination of case hardened special alloy screw and special high tensile strength brass worm wheel ensures exceptional wear resistant and long durability
- Dual lead worm screw for easy backlash adjustment
- Large diameter worm wheel for extra rigidity, smoothness and torque transfer efficiency
- Double bearing design and solid one piece face plate & spindle for extra rigidity
- Large thru hole standard on most face plate sizes
- Available as :
 - o Integrated 4th axis
 - o Indexer with a programmable control box
 - o Optional air purge for water protection
 - o Left hand configurations
 - o Super high resolution with optional rotary scale

Model		AX4-120R		AX4-170R		AX4-200R		AX4-250R		AX4-320R	
Table Diameter		120mm	4.72"	170mm	6.69"	200mm	7.87"	250mm	9.84"	320mm	12.6"
Center Height		115mm	4.53"	135mm	5.31"	160mm	6.30"	185mm	7.28"	210mm	8.27"
Center Hole		30mm H7	1.18" H7	35mm H7	1.38" H7	35mm H7	1.38" H7	70mm H7	2.76" H7	110mm H7	4.33" H7
Guide Block Width		14mm h7	0.55" h7	18mm h7	0.71" h7	18mm h7	0.71" h7	18mm h7	0.71" h7	18mm h7	0.71" h7
T-slot Width		10mm H7	0.39" H7	12mm H7	0.47" H7	12mm H7	0.47" H7	12mm H7	0.47" H7	14mm h7	0.55" h7
FANUC servo motor		aiF2		aiF4		aiF4		aiF4/8		aiF12	
Max. RPM		33.3		22.2		22.2		11.1 / 22.2		11.1 / 22.2	
Gear Ratio		1:60		1:90		1:90		1:180/1:90		1:180/1:90	
Indexing Accuracy arc sec.		± 30		± 12.5		± 12.5		± 10		± 10	
Net Weight without motors		28kg	62lbs	70kg	155lbs	84kg	185lbs	124kg	275lbs	210kg	463lbs
Clamp Torque	Pneumatic @72psi	118Nm	87ft-lbs	245Nm	181ft-lbs	245Nm	181ft-lbs	461Nm	340ft-lbs	696Nm	514ft-lbs
	Hydraulic @286psi	235Nm	173ft-lbs	490Nm	361ft-lbs	490Nm	361ft-lbs	921Nm	679ft-lbs	1392Nm	1026ft-lbs
Vertical Weight Limit		35kg	77lbs	75kg	165lbs	100kg	220lbs	125kg	275lbs	150kg	330lbs
Horizontal Weight Limit		75kg	165lbs	150kg	330lbs	200kg	440lbs	300kg	660lbs	350kg	770lbs
Horizontal Load Limit		5,880 N	1,322lbf	7,840 N	1,762lbf	8,055N	1,810lbf	1,1840N	2,662lbf	1,3475N	3,030lbf
Circumference Load Force		118Nm	87ft-lbs	245Nm	181ft-lbs	245Nm	181ft-lbs	461Nm	340ft-lbs	696Nm	514ft-lbs
Vertical Load Limit		118Nm	87ft-lbs	392Nm	290ft-lbs	490Nm	361ft-lbs	705Nm	520ft-lbs	900Nm	665ft-lbs

* All specifications are subject to change without prior notice.

Standard Models AX4-120R, 170R, 200R, 250R, 320R

AX4-120R

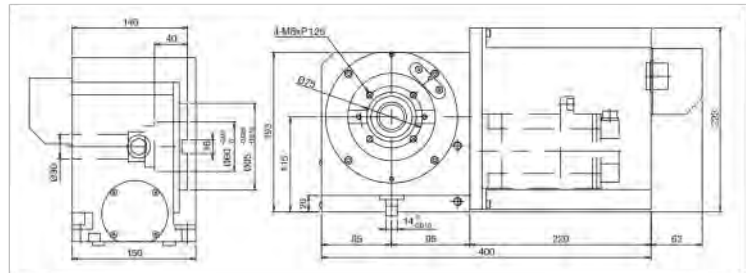

AX4-170R

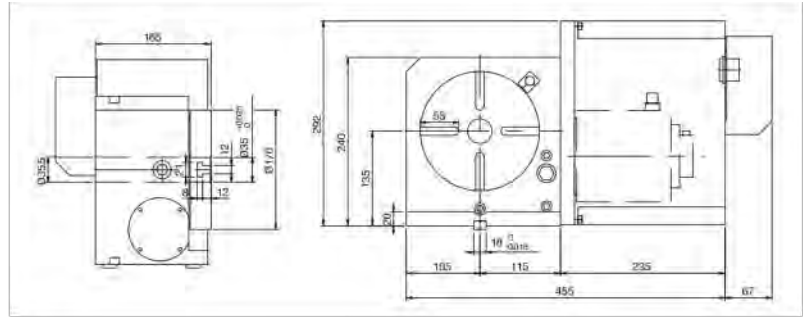

AX4-200R

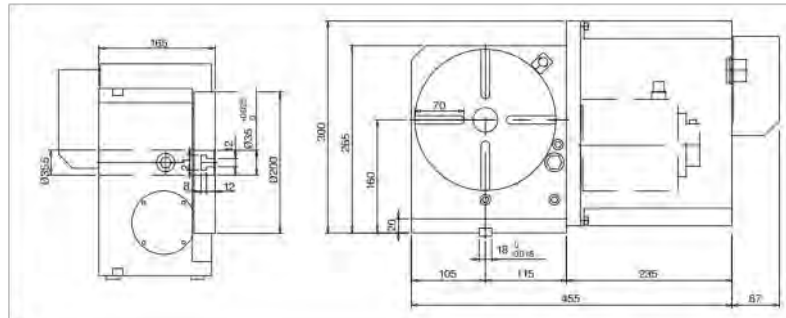

AX4-250R

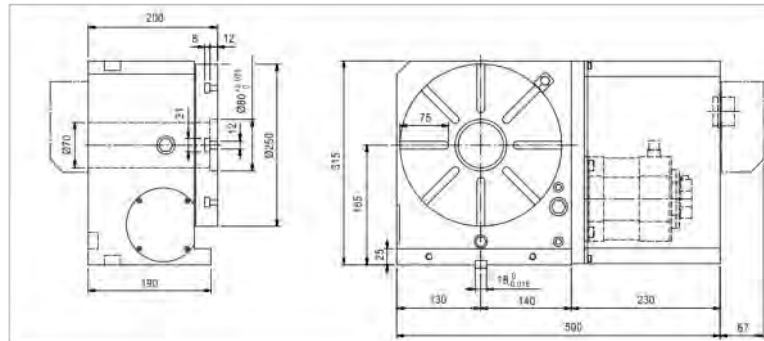



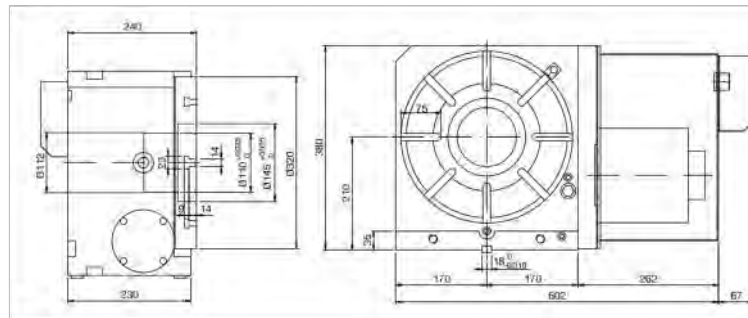

AX4-320R





- Combination of case hardened special alloy screw and special high tensile strength brass worm wheel ensures exceptional wear resistant and long durability.
- Dual lead worm screw for easy backlash adjustment
- Large diameter worm wheel for extra rigidity, smoothness and torque transfer efficiency
- Double bearing design and solid one piece face plate & spindle for extra rigidity
- Large thru hole standard on most face plate sizes
- Available as :
 - o Integrated 4th axis
 - o Indexer with a programmable control box
 - o Optional air purge for water protection
 - o Left hand configurations
 - o Super high resolution with optional rotary scale

Model	AX4-400R		AX4-500R		AX4-630R		AX4-800R		
Table Diameter	400mm	15.75"	500mm	19.68"	630mm	24.8"	800mm	31.5"	
Center Height	250mm	9.84"	310mm	12.2"	400mm	15.75"	480mm	18.9"	
Center Hole	150mm H7	5.91" H7	180mm H7	7.09" H7	254mm H7	10 H7"	254mm H7	10" H7	
Guide Block Width	18mm h7	0.71" h7	18mm h7	0.71" h7	18mm h7	0.71" h7	22mm h7	0.87" h7	
T-slot Width	14mm H7	0.55" H7	18mm H7	0.71" H7	18mm H7	0.71" H7	20mm H7	0.79" H7	
FANUC servo motor	aiF12		aiF12/aiF22		aiF22		aiF22		
Max. RPM	22.2		16.7		11.1		11.1		
Gear Ratio	1:90		1:120		1:180		1:180		
Indexing Accuracy arc sec.	± 7.5		± 7.5		± 7.5		± 7.5		
Net Weight without motors	280kg	616lbs	380kg	836lbs	860kg	1,892lbs	1,200kg	2,640lbs	
Clamp Torque	Pneumatic @72psi		1,225Nm		3,430Nm		4,214Nm		
	Hydraulic @286psi		2,450Nm		6,860Nm		7,588ft-lbs		
Vertical Weight Limit		300kg	660lbs	350kg	770lbs	400kg	880lbs	500kg	1,100lbs
Horizontal Weight Limit		500kg	1,100lbs	600kg	1,320lbs	800kg	1,760lbs	1,000kg	2,200lbs
Horizontal Load Limit		15,533 N	3,942lbf	18,424 N	4142lbf	20,384 N	4582lbf	25,480 N	5,728lbf
Circumference Load Force		902Nm	665ft-lbs	1,225Nm	903ft-lbs	3,432Nm	2,529ft-lbs	4,214Nm	3,108ft-lbs
Vertical Load Limit		1,195Nm	882ft-lbs	1,617Nm	1,192ft-lbs	2,234Nm	1,648ft-lbs	2,793Nm	2,060ft-lbs

* All specifications are subject to change without prior notice.

AX4-400R

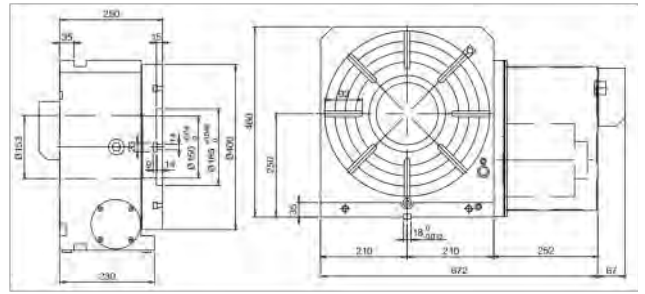

AX4-500R

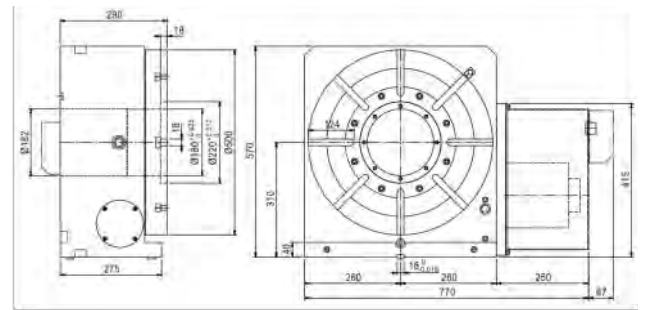

AX4-630R

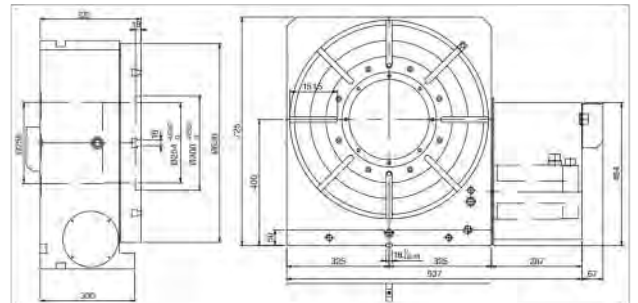



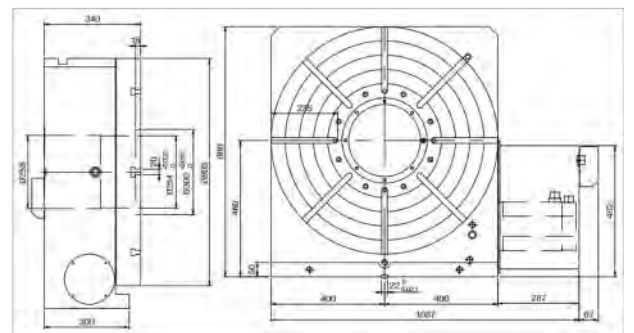

AX4-800R

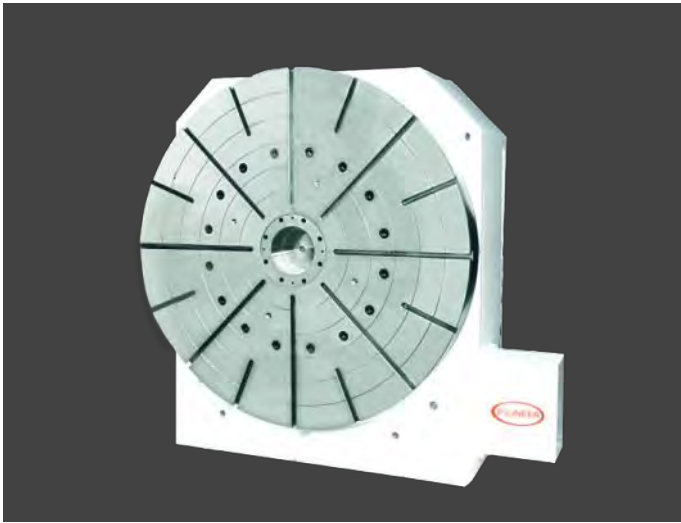

Large Size AX Rotary Table AX4-1000, 1200, 1500, 2000 H/V



- Table size available from 1,000mm to 2,000mm
- Available in both vertical & horizontal position
- Heavy loading capacity axial-radial roller bearings are incorporated to provide higher rigidity
- Custom design available for various applications
- Super high resolution of +/- 5 sec with direct measuring rotary scale available as option *Available resolution varies depending on the grade of the rotary scale

Model	AX4-1000HV		AX4-1200HV		AX4-1500HV		AX4-2000HV	
Table Diameter	1000mm	39.37"	1,200mm	47.24"	1,500mm	59.06"	2,000mm	78.74"
Center Height in Vertical	650mm	25.59"	810mm	31.89"	900mm	35.43"	1100mm	43.31"
Table Height in Horizontal	530mm	20.87"	530mm	20.87"	700mm	27.56"	800mm	31.5"
Center Holes	100x60mm	3.94x2.36"	100x60mm	3.94x2.36"	200x70mm	7.87x2.76"	200x70mm	7.87x2.76"
Guide Block Width	22mm h7	0.87" h7	22mm h7	0.87" h7	28mm H7	1.10" H7	36mm h7	1.42" h7
T-slot Width	22mm H7	0.87" H7	22mm H7	0.87" H7	22mm H7	0.87" H7	28mm H7	1.10" H7
FANUC servo motor	aiF30		aiF30		aiF30		aiF40	
Gear Ratio	1:360		1:360		1:720		1:720	
Min. Indexing (degree)	0.001°		0.001°		0.001°		0.001°	
Max. RPM	5.56		5.56		2.78		2.78	
Clamp System	Hydraulic							
Clamp Torque @500psi	10,780Nm	7,950ft-lbs	10,780Nm	7,950ft-lbs	14,700Nm	10,840 ft-lbs	19,600Nm	14,454 ft-lbs
Indexing Accuracy arc sec.	± 7.5		± 7.5		± 7.5		± 7.5	
Indexing Accuracy w/ Rotary Scale (optional)	± 5		± 5		± 5		± 5	
Net weight without motors	2,500kg	5,500lbs	3,500kg	7,700lbs	6,000kg	13,200lbs	8,000kg	17,600lbs
Vertical Weight Limit 	1,500kg	3,300lbs	2,000kg	4,400lbs	3,000kg	6,600lbs	4,000kg	8,800lbs
Horizontal Weight Limit 	3,500kg	7,700lbs	5,000kg	11,000lbs	8,000kg	17,600lbs	10,000kg	22,000lbs
Horizontal Load Limit 	29,400 N	6,610lbf	29,400 N	6,610lbf	49,000 N	11,015lbf	58,800 N	13,218lbf
Circumference Load Force 	10,780Nm	7,950ft-lbs	10,780Nm	7,950ft-lbs	14,700Nm	10,840 ft-lbs	19,600Nm	14,454 ft-lbs
Vertical Load Limit 	9,800Nm	7,227ft-lbs	9,800Nm	7,227ft-lbs	14,700Nm	10,840 ft-lbs	19,600Nm	14,454 ft-lbs

* All specifications can be modified according to customer's requirement

Large Size AX Rotary Table AX4-1000, 1200, 1500, 2000 H/V

AX-1000

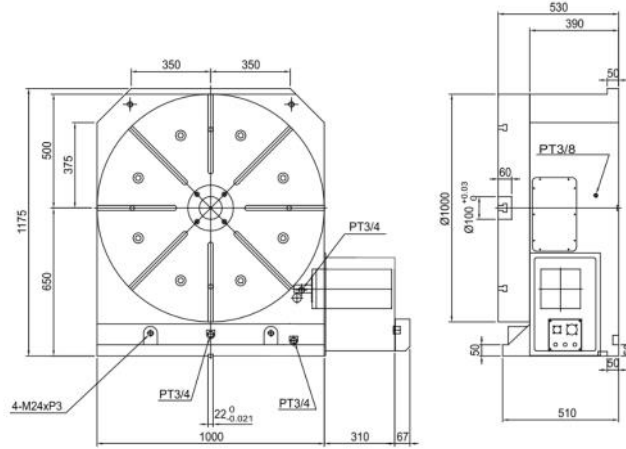

AX-1200

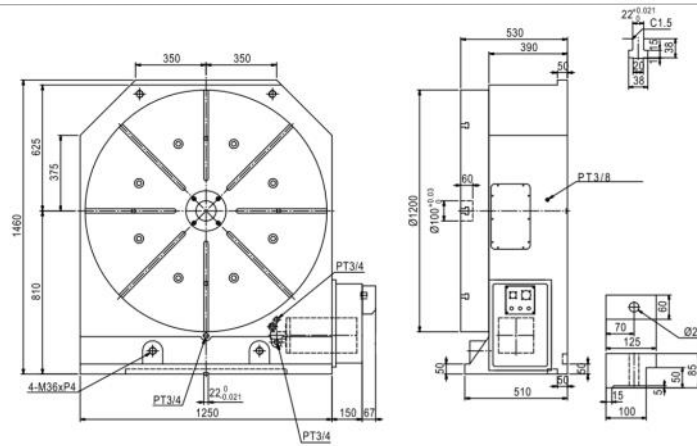

AX-1500

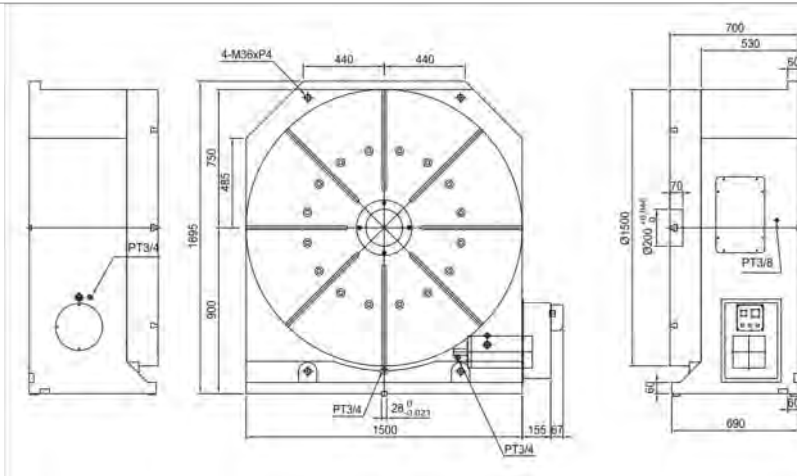

AX-2000

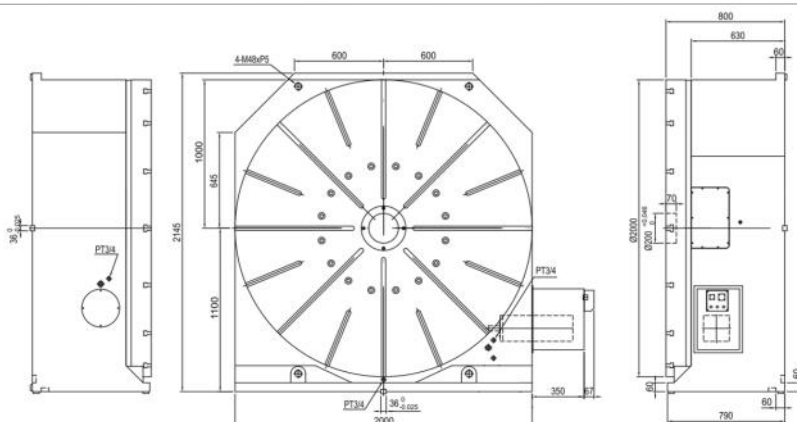





Back-Mounted Models AX4-120RB, 170RB, 200RB, 250RB



- Back-Mounted Motor, avoid the interference with M/C splash guard
- Suitable for small-size of AX Machining / Tapping-Center.

This model cannot be installed for horizontal use.

Model	AX4-120RB		AX4-170RB		AX4-200RB		AX4-250RB		
Table Diameter	120mm	4.72"	170mm	6.69"	200mm	7.87"	250mm	9.84"	
Center Height	115mm	4.53"	135mm	5.31"	160mm	6.30"	185mm	7.28"	
Center Hole	30mm H7	1.18" H7	35mm H7	1.38" H7	35mm H7	1.38" H7	52mm H7	2.05" H7	
Guide Block Width	14mm h7	0.55" h7	18mm h7	0.71" h7	18mm h7	0.71" h7	18mm h7	0.71" h7	
T-slot Width	10mm H7	0.39" H7	12mm H7	0.47" H7	12mm H7	0.47" H7	12mm H7	0.47" H7	
FANUC servo motor	aiF2		aiF4		aiF4		aiF4		
Max. RPM	33.3		22.2		22.2		22.2		
Gear Ratio	1:60		1:90		1:90		1:90		
Indexing Accuracy arc sec.	± 30		± 12.5		± 12.5		± 12.5		
Net Weight without motors	70kg	154lbs	70kg	154lbs	84kg	185lbs	124kg	273lbs	
Clamp Torque	Pneumatic @72psi	118Nm	87ft-lbs	245Nm	180ft-lbs	245Nm	180ft-lbs	460Nm	340ft-lbs
	Hydraulic @286psi	235Nm	174ft-lbs	490Nm	362ft-lbs	490Nm	362ft-lbs	922Nm	680ft-lbs
Vertical Weight Limit 	35kg	77lbs	75kg	165lbs	100kg	220lbs	125kg	275lbs	
Horizontal Weight Limit 	75kg	165lbs	150kg	330lbs	200kg	440lbs	300kg	660lbs	
Horizontal Load Limit 	5,880 N	1,322lbf	7,840 N	1,762lbf	8,055 N	1,811lbf	11,838 N	2,661lbf	
Circumference Load Force 	118Nm	87ft-lbs	245Nm	180ft-lbs	245Nm	180ft-lbs	460Nm	340ft-lbs	
Vertical Load Limit 	118Nm	87ft-lbs	392Nm	290ft-lbs	490Nm	363ft-lbs	705Nm	522ft-lbs	

* All specifications can be modified according to customer's requirement

Back-Mounted Models AX4-120RB, 170RB, 200RB, 250RB

AX-170RB

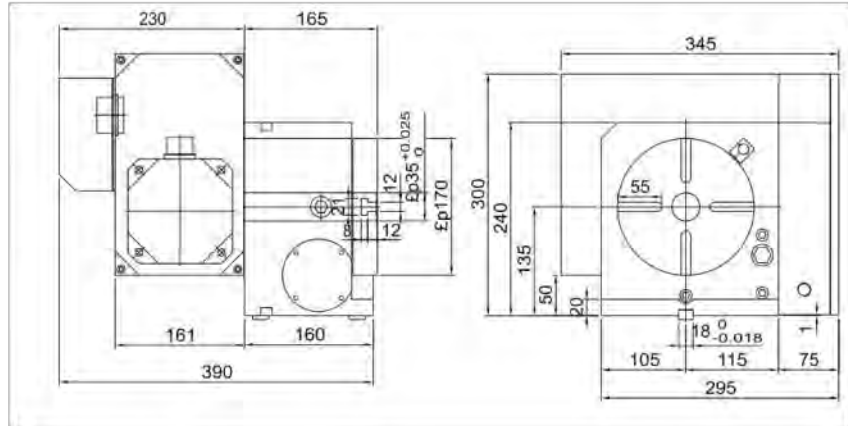

AX-200RB

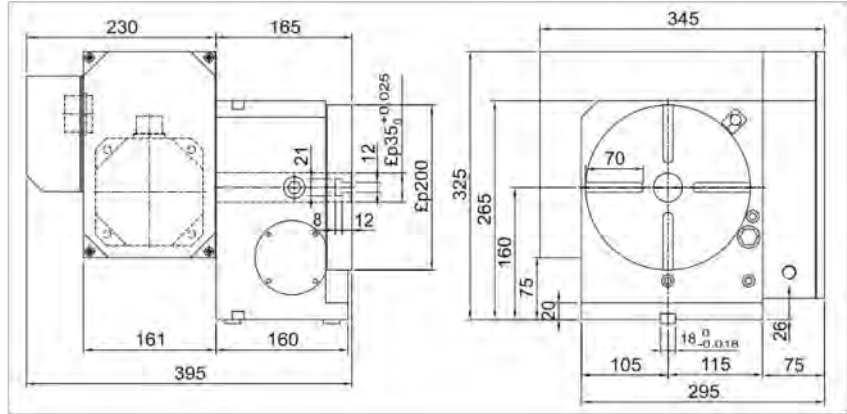



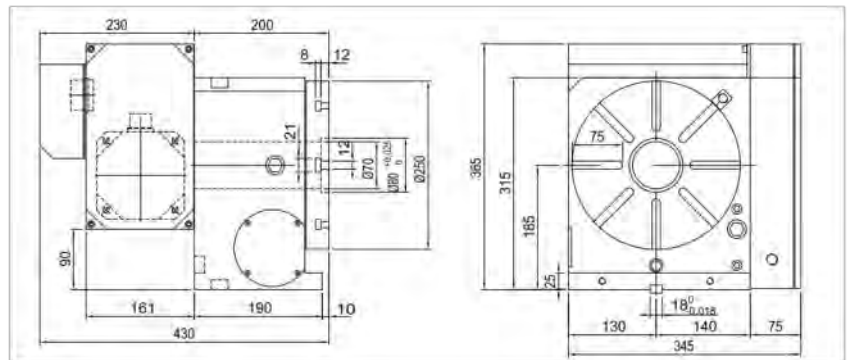

AX-250RB



Roller Gear Cam—Rotary Table RCT200R-001



- Roller Cam Gear System has many advantages over conventional worm gearing system
 - Higher RPM
 - Higher rigidity
 - Higher accuracy compared to conventional worm gear system
- Maintenance Free – unique Zero-Backlash design requires no backlash adjustments
- Available as :
 - Integrated 4th axis
 - Indexer with a programmable control box
 - Optional air purge for water protection
 - Left hand configurations
 - Super high resolution with optional rotary scale

Model	RCT-170R		RCT-200R		RCT-250R		RCT-320R		
Table Diameter	170mm	6.69"	200mm	7.87"	250mm	9.84"	320mm	12.60"	
Center Height	135mm	5.31"	160mm	6.30"	185mm	7.28"	210mm	8.27"	
Center Hole	35mm H7 /35mm	1.37" H7 / 1.37"	35mm H7 /35mm	1.37" H7 / 1.37"	70mm H7 /70mm	2.76" H7 / 2.76"	145mm H7 /80mm	5.71" H7 / 3.15"	
Guide Block Width	18mm h7	0.71" h7	18mm h7	0.71" h7	18mm h7	0.71" h7	18mm h7	0.71" h7	
T-slot Width	12mm H7	0.47" H7	12mm H7	0.47" H7	12mm H7	0.47" H7	14mm H7	0.55" H7	
FANUC servo motor	aiF4		aiF4		aiF8		aiF8		
Max. RPM	66.6		50		50		33.3		
Gear Ratio	1:30		1:40		1:40		1:60		
Indexing Accuracy arc sec.	± 10		± 10		± 10		± 10		
Net Weight without motors	65kg	143lbs	80kg	176lbs	120kg	265lbs	200kg	441lbs	
Clamp Torque	Pneumatic @72psi	245Nm	181ft-lbs	245Nm	181ft-lbs	441Nm	325ft-lbs	696Nm	513ft-lbs
	Hydraulic @286psi	490Nm	361ft-lbs	490Nm	361ft-lbs	882Nm	650ft-lbs	1,392Nm	1,026ft-lbs
Vertical Weight Limit 	75 kg	165lbs	75 kg	165lbs	100 kg	220lbs	150 kg	330lbs	
Horizontal Weight Limit 	150 kg	331lbs	150 kg	330.69lbs	250 kg	551lbs	350 kg	771lbs	
Horizontal Load Limit 	7840 N	1762lbf	7,840 N	1762lbf	13,720 N	3,084lbf	19,600 N	4,406lbf	
Circumference Load 	245Nm	181ft-lbs	245Nm	181ft-lbs	441Nm	325ft-lbs	696Nm	514ft-lbs	
Vertical Load Limit 	392 Nm	289ft-lbs	392 Nm	289ft-lbs	980Nm	723ft-lbs	1,960Nm	1,445ft-lbs	

* All specifications are subject to change without prior notice.

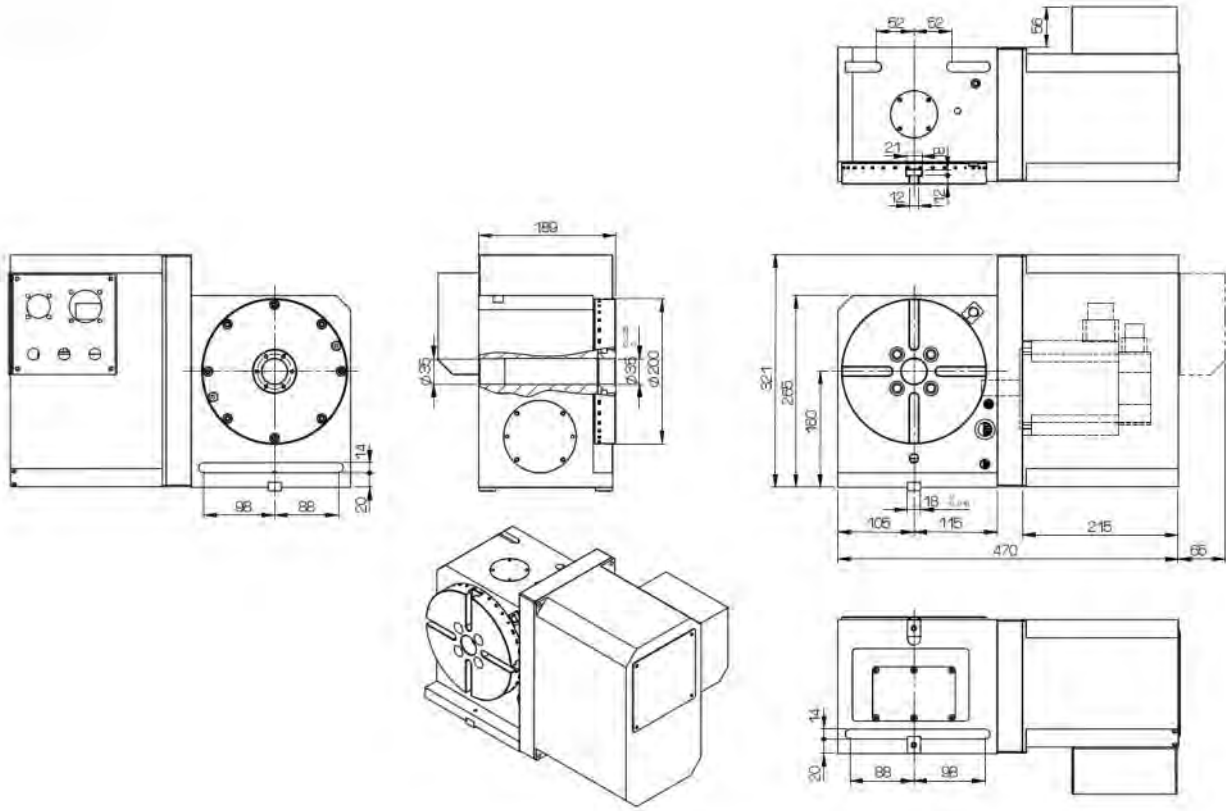

Roller Gear Cam Drive Assembly



Multi-Spindle Models AX4-120R-2W-FA, 120R-32W-FA, 120R-42W-FA



- Increase productivity - Available up to 4 spindles
- Combination of case hardened special alloy screw and special high tensile strength brass worm wheel ensures exceptional wear resistant and long durability.
- Dual lead worm screw for easy backlash adjustment
- Large diameter worm wheel for extra rigidity, smoothness and torque transfer efficiency
- Double bearing design and solid one piece face plate & spindle for extra rigidity
- Available as :
 - o Integrated 4th axis
 - o Indexer with a programmable control box
 - o Optional air purge for water protection

Model	AX4-120R-2W (3W/4W)		
Table Diameter	120mm	4.72"	
Center Height	135mm	5.31"	
Center Hole	30mm H7	1.18" H7	
Guide Block Width	14mm h7	0.55" h7	
T-slot Width	10mm h7	0.39" h7	
FANUC servo motor	aiF4		
Max. RPM	33.3		
Gear Ratio	1:60		
Indexing Accuracy arc sec.	± 7.5 seconds		
Net Weight without motors			
Clamp Torque	Pneumatic @72psi	118Nm	87ft-lbs
	Hydraulic @286psi	490Nm	361ft-lbs
Vertical Weight Limit	35kg	77lbs	
Horizontal Weight Limit	75kg	165lbs	
Horizontal Load Limit	7840 N	1762lbf	
Circumference Load Force	118Nm	87ft-lbs	
Vertical Load Limit	176Nm	130lbf	

* All specifications are subject to change without prior notice.

AX4H-120R-2W-FA

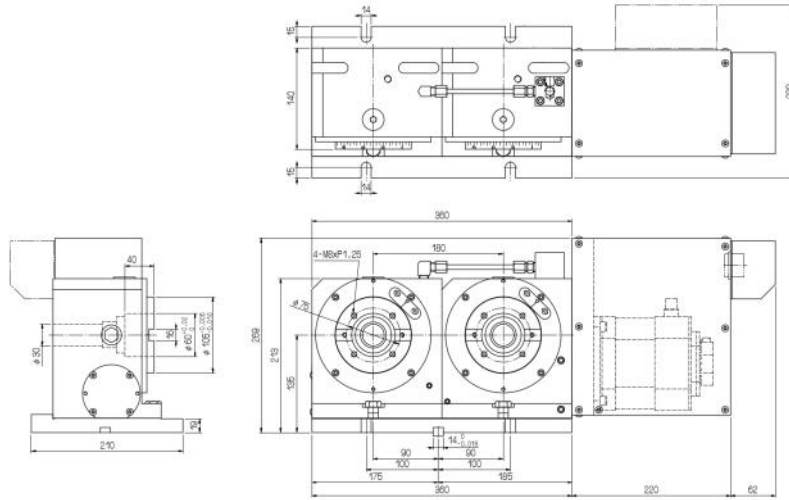

AX4H-120R-3W-FA

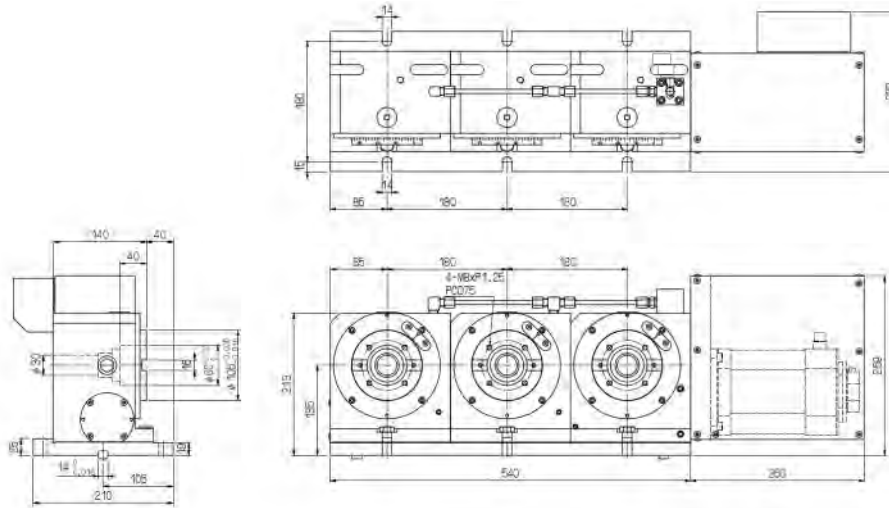

AX4H-120R-4W-FA

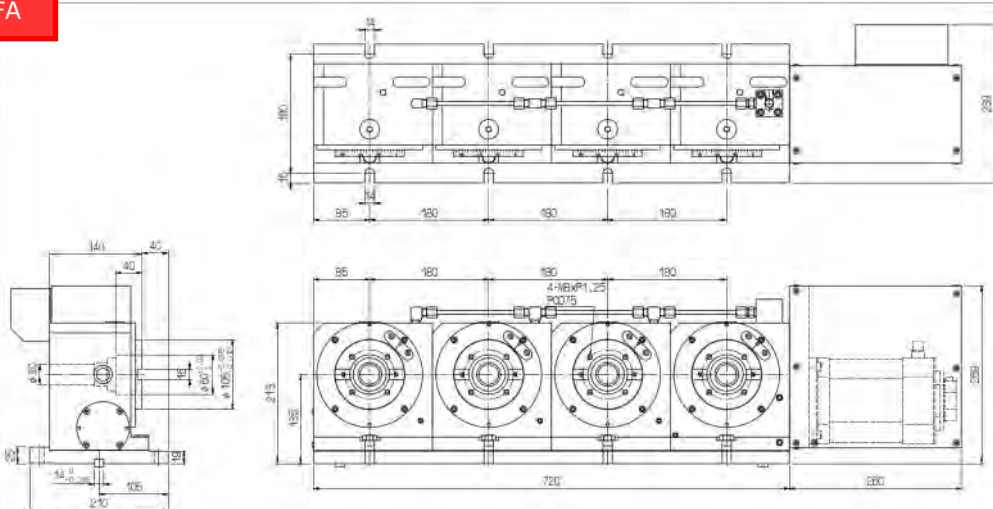

Multi-Spindle Models AX4-120R, 170R, 200R, 250R, 320R 2W/3W



- Increase productivity - Available up to 4 spindles
- Combination of case hardened special alloy screw and special high tensile strength brass worm wheel ensures exceptional wear resistant and long durability.
- Dual lead worm screw for easy backlash adjustment
- Large diameter worm wheel for extra rigidity, smoothness and torque transfer efficiency
- Double bearing design and solid one piece face plate & spindle for extra rigidity
- Available as :
 - o Integrated 4th axis
 - o Indexer with a programmable control box
 - o Optional air purge for water protection

Model	AX4-200R-2W (3W)		
Table Diameter	200mm	7.87"	
Center Height	190mm	7.48"	
Center Hole	35mm H7	1.38" H7	
Guide Block Width	18mm h7	0.71" h7	
T-slot Width	12mm H7	0.47" H7	
FANUC servo motor	aiF8		
Max. RPM	22.2		
Gear Ratio	1:90		
Indexing Accuracy arc sec.	± 7.5		
Net Weight without motors	270kg	595lbs	
Clamp Torque	Pneumatic @72psi	245Nm	181 ft-lbs
	Hydraulic @286psi	490Nm	362 ft-lbs
Vertical Weight Limit	100kg	220lbs	
Horizontal Weight Limit	200kg	440lbs	
Horizontal Load Limit	8,055 N	5,941ft-lbs	
Circumference Load Force	245Nm	181ft-lbs	
Vertical Load Limit	127Nm	94ft-lbs	

* All specifications are subject to change without prior notice.

AX4-200R-2W

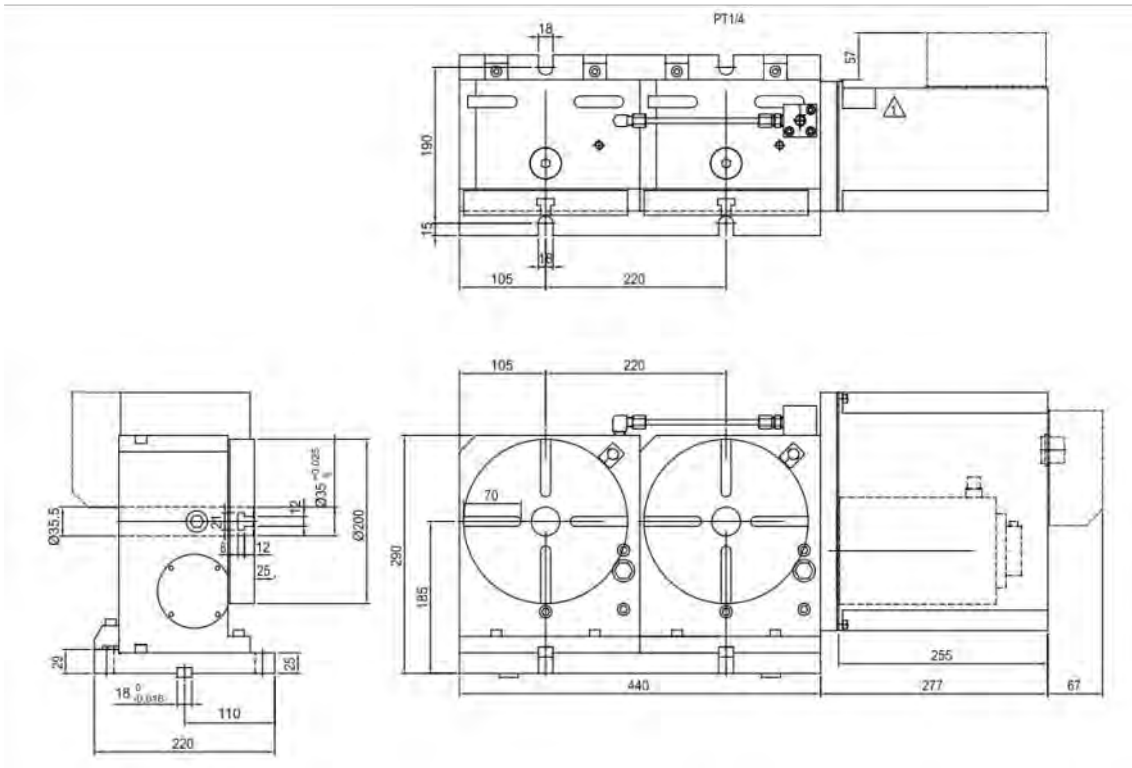

AX4-200R-3W

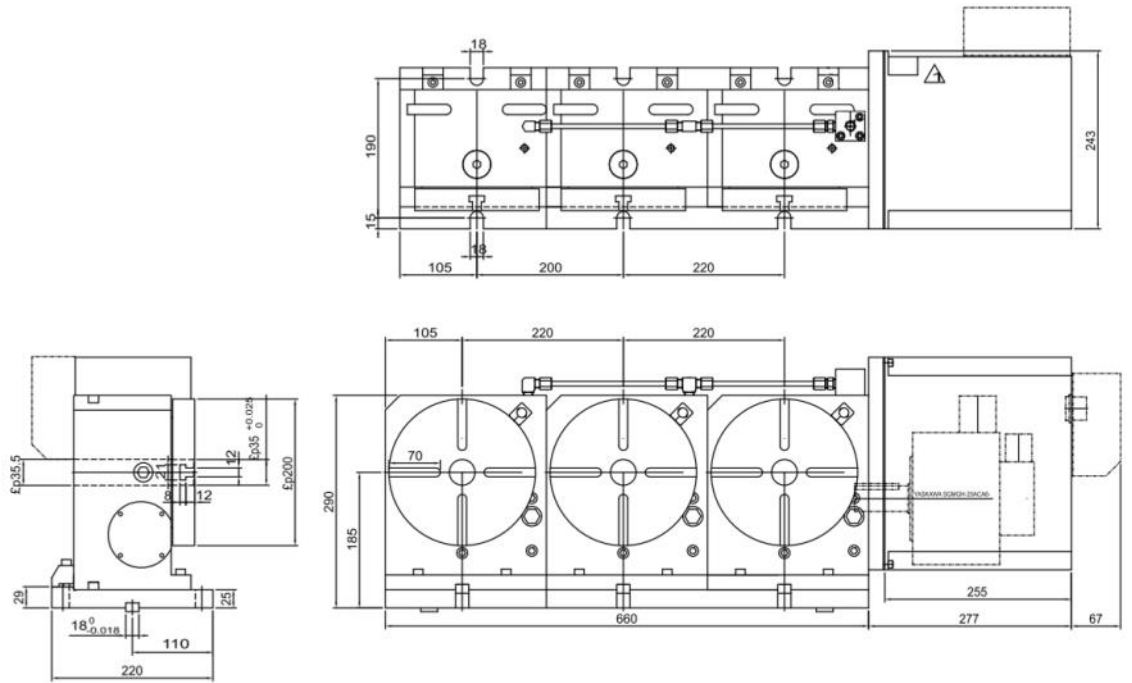



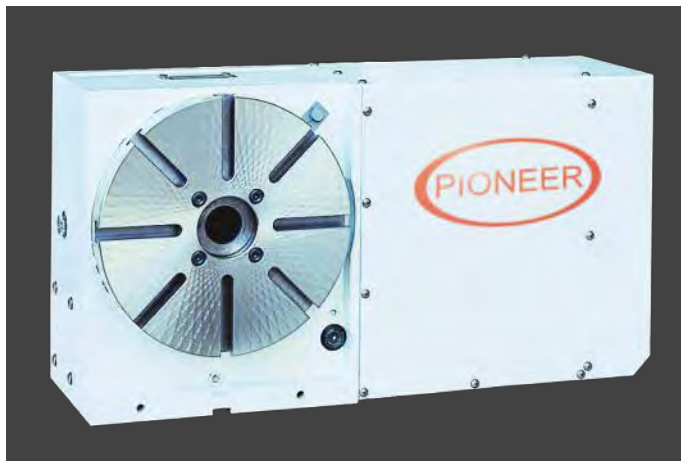

NC Coupling Indexer AX4H-250R, 320R, 400, 500R



- Built-in hirth coupling ensures exceptional indexing accuracy
- No lift up of the face plate during rotation

Available as :

- Integrated 4th axis
- Indexer with a programmable control box
- Optional air purge for water protection

Model	AX4H-250R		AX4H-320R		AX4H-400R		AX4H-500R	
Table Diameter	250mm	9.84"	320mm	12.6"	400mm	15.75"	500mm	19.69"
Center Height	185mm	7.28"	210mm	8.27"	250mm	9.84"	310mm	12.2"
Center Hole	30mm H7	1.8" H7	80mm H7	3.15" H7	70mm H7	2.76" H7	80mm H7	3.15" H7
Guide Block Width	18mm h7	0.71" h7	18mm h7	0.71" h7	18mm h7	0.71" h7	18mm h7	0.71" h7
T-slot Width	12mm H7	0.47" H7	14mm H7	0.55" H7	14mm H7	0.55" H7	14mm H7	0.55" H7
FANUC servo motor	aiF8		aiF12		aiF12		aiF12	
Max. RPM	22.2		22.2		22.2		11.1	
Gear Ratio	1:90		1:90		1:90		1:180	
Indexing Accuracy arc sec.	± 5		± 5		± 5		± 5	
Net Weight without motors	110kg	242lbs	240kg	528lbs	280kg	616lbs	320kg	704lbs
Vertical Weight Limit 	125kg	275lbs	150kg	330lbs	250kg	550lbs	400kg	880lbs
Horizontal Weight Limit 	300kg	660lbs	350kg	770lbs	500kg	1,100lbs	600kg	1,320lbs
Horizontal Load Limit 	34,300 N	7,710lbf	49,000 N	11,015lbf	58,800 N	13,218lbf	68,600 N	15,421lbf
Circumference Load Force 	4,900Nm	3,614ft-lbs	4,900Nm	3,614ft-lbs	5,880Nm	4,336ft-lbs	6,860Nm	5,059ft-lbs
Vertical Load Limit 	1,372Nm	1,012ft-lbs	3,920Nm	2,891ft-lbs	3,920Nm	2,891ft-lbs	3,920Nm	2,891ft-lbs

* All specifications are subject to change without prior notice.

AX4H-250R

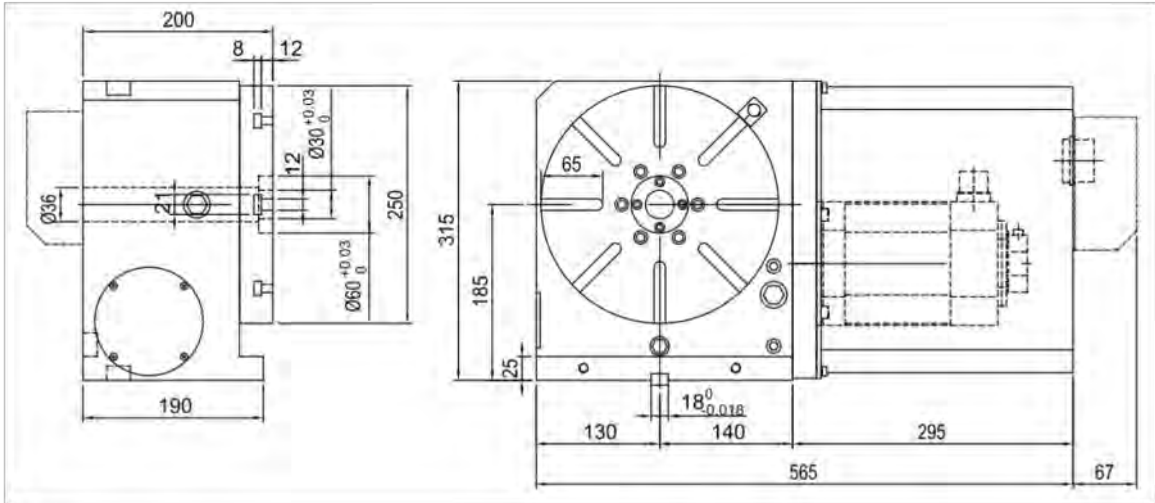

AX4H-320R

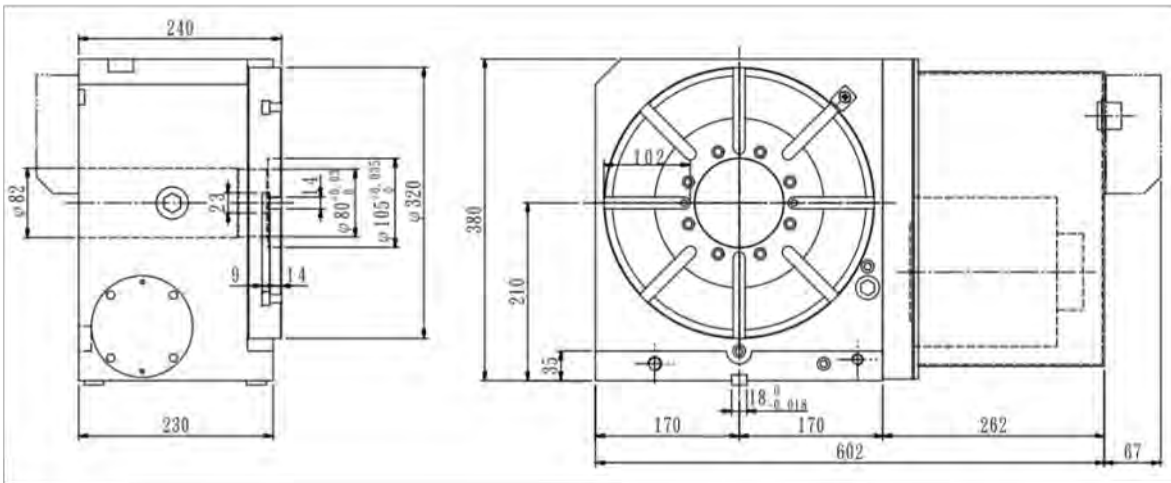

AX4H-400R

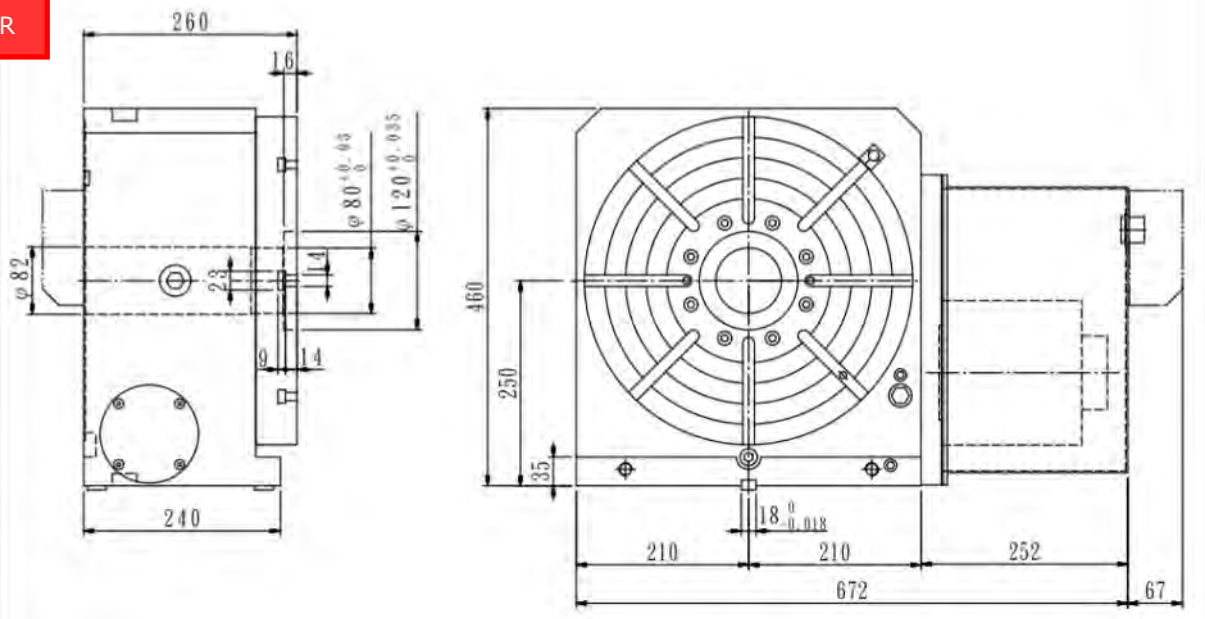

3 Pieces Hirth Coupling

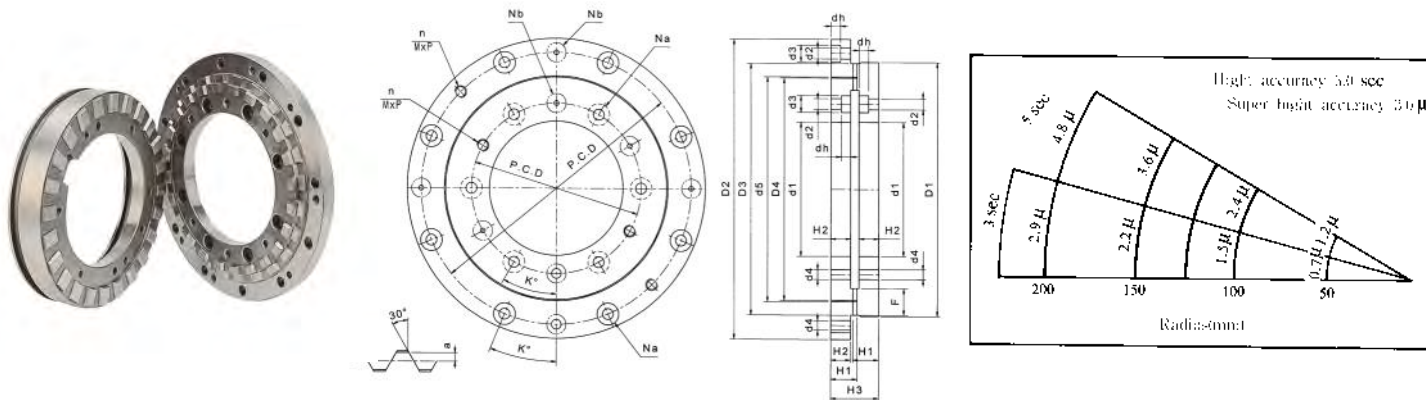

NO.	Model NO.	Outside DIA	Outside DIA.	Inside DIA.	Number of teeth	Teeth profile	Top end thickness of teeth	Inside thickness	Total thickness
		D1	D2	d1					
1	x.V1 024135-060	135	-	60	24	18	18.75	13.5	34
	VO	-	175	-	24	-	18.75	13.5	34
2	x.V1 024200-120	200	-	120	24	20	21.75	16.5	40
	VO	-	255	-	24	-	21.75	16.5	40
3	x.V1 030200-120	200	-	120	30	20	21.75	16.5	40
	VO	-	255	-	30	-	21.75	16.5	40
4	x.V1 0360250-180	250	-	180	360	8	20.2	18	40
	VO	-	300	-	360	8	20.2	18	40
5	x.V1 024270-160	270	-	160	24	24	21.75	16.5	40
	VO	-	330	-	24	-	21.75	16.5	40
6	x.V1 030270-160	270	-	160	30	24	21.75	16.5	40
	VO	-	330	-	30	-	21.75	16.5	40
7	x.V1 0360270-160	270	-	160	360	10	20.2	18	40
	VO	-	300	-	360	10	20.2	18	40
8	x.V1 048335-220	335	-	220	48	24	25.75	20.5	48
	VO	-	400	-	48	-	25.75	20.5	48
9	x.V1 048425-300	425	-	300	48	28	26.75	21.5	50
	VO	-	482	-	48	-	26.75	21.5	50
10	x.V1 060425-3000	425	-	300	60	28	26.75	21.5	50
	VO	-	482	-	60	-	26.75	21.5	50
11	x.V1 072425-300	425	-	300	72	28	26.75	21.5	50
	VO	-	482	-	72	-	26.75	21.5	50
12	x.V1 0360425-300	425	-	300	360	20	26	21.5	50
	VO	-	482	-	360	-	26	21.5	50
13	x.V1 048540-415	540	-	415	48	32	29.25	24	55
	VO	-	604	-	48	-	29.25	24	55
14	x.V1 060540-415	540	-	415	60	32	29.25	24	55
	VO	-	604	-	60	-	29.25	24	55
15	x.V1 072540-415	540	-	415	72	32	29.25	24	55
	VO	-	604	-	72	-	29.25	24	55
16	x.V1 0360540-415	540	-	415	360	24	29	24	55
	VO	-	604	-	360	-	29	24	55

NO.	Model NO.	Fixed bolt hole					Positioning pin hole				Withdraw bolt hole			Pitch of top end	Allowance of pitch top end
		Number of holes	P . C . D.	Hole DIA.	Top DIA.	Depth of hole	Number of pin hole	P . C . D	Angle of hole	Hole DIA.	Number of teeth hole	P . C . D	Spec. of teeth		
1	x.V1 024135-060	6	80	6.6	11	6	3	80	30°	8	2	80	M8x1.25	1.75	1.55
	VO	8	150	M10	14	8.5	3	150	22.5°	8	2	150	M8x1.25	1.75	1.55
2	x.V1 024200-120	8	140	9	14	8	3	140	22.5°	8	2	140	M8x1.25	1.75	1.55
	VO	10	224	M12	17.5	10.5	3	224	18°	10	2	224	M10x1.50	1.75	1.55
3	x.V1 030200-120	8	140	9	14	8	3	140	22.5°	8	2	140	M8x1.25	1.75	1.55
	VO	10	224	M12	17.5	10.5	3	224	18°	10	2	224	M10x1.5	1.75	1.55
4	x.V1 0360250-180	12	205	11	17.5	10	3	205	15°	10	2	205	M8x1.5	0.2	0.17
	VO	12	270	M12	17.5	10.5	3	270	15°	12	4	270	M12x1.75	0.2	0.17
5	x.V1 024270-160	8	195	11	17.5	10	3	195	22.5°	10	2	195	M10x1.50	1.75	1.55
	VO	12	300	M14	20	12.5	3	300	15°	12	4	300	M12x1.75	1.75	1.55
6	x.V1 030270-160	8	195	11	17.5	10	3	195	22.5°	10	2	195	M10x1.50	1.75	1.55
	VO	12	300	M14	20	12.5	3	300	15°	12	4	300	M12x1.75	1.75	1.55
7	x.V1 0360270-160	8	220	11	17.5	10	3	220	22.5°	10	2	220	M10x1.5	0.2	0.17
	VO	12	300	M14	20	12.5	3	300	15°	12	4	300	M12x1.75	0.2	0.17
8	x.V1 048335-220	12	258	13	20	12	3	258	15°	12	4	258	M12x1.75	1.75	1.55
	VO	12	360	13	20	12.5	3	360	15°	12	4	360	M12x1.75	1.75	1.55
9	x.V1 048425-300	12	335	13	20	12	3	335	15°	12	4	335	M12x1.75	1.75	1.56
	VO	12	450	13	20	12.5	3	450	15°	12	4	450	M12x1.75	1.75	1.55
10	x.V1 060425-3000	12	335	13	20	12	3	335	15°	12	4	335	M12x1.75	1.75	1.55
	VO	12	450	13	20	12.5	3	450	15°	12	4	450	M12x1.75	1.75	1.55
11	x.V1 072425-300	12	335	13	20	12	3	335	15°	12	4	335	M12x1.75	1.75	1.55
	VO	12	450	13	20	12.5	3	450	15°	12	4	450	M12x1.75	1.75	1.55
12	x.V1 0360425-300	12	335	13	20	12	3	335	15°	12	4	335	M12x1.75	1	0.9
	VO	12	450	13	20	12.5	3	450	15°	12	4	450	M12x1.75	1	0.9
13	x.V1 048540-415	12	450	13	20	12	3	450	15°	12	4	450	M12x1.75	1.75	1.55
	VO	12	570	17	26	16.5	3	570	15°	12	4	570	M12x1.75	1.75	1.55
14	x.V1 060540-415	12	450	13	20	12	3	450	15°	12	4	450	M12x1.75	1.75	1.55
	VO	12	570	17	26	16.5	3	570	15°	12	4	570	M12x1.75	1.75	1.55
15	x.V1 072540-415	12	450	13	20	12	3	450	15°	12	4	450	M12x1.75	1.75	1.55
	VO	12	570	17	26	16.5	3	570	15°	12	4	570	M12x1.75	1.75	1.55
16	x.V1 0360540-415	12	450	13	20	12	3	450	15°	12	2	450	M12x1.75	1.5	1.4
	VO	12	570	17	26	16.5	3	570	15°	12	2	570	M12x1.75	1.5	1.4

2 Pieces Hirth Coupling

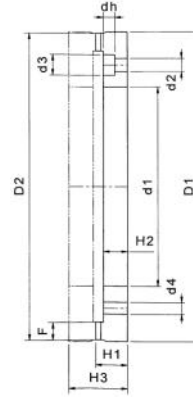
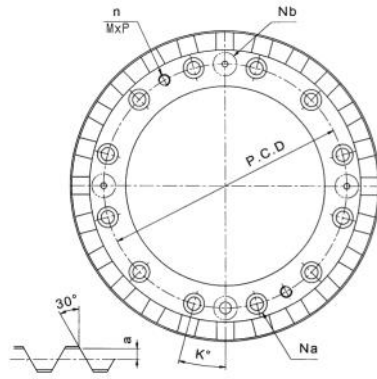

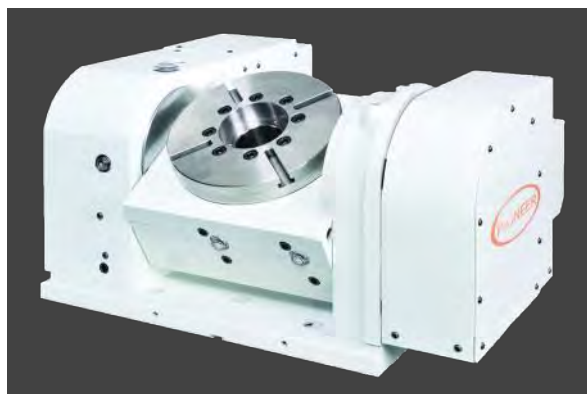

NO.	Model NO.	Outside DIA	Outside DIA.	Inside DIA.	Number of teeth	Teeth profile	Top end thickness of teeth	Inside thickness	Total thickness
		D1	D2	d1	N	F	H1	H2	H3
1	24080-44XV	80	79	44	24	8	15.3	12	29
2	20100-40XV	100	98	40	20	9	18.37	14	34
3	24100-40XV	100	98	40	24	8	18.3	14	34
4	24120-60XV	120	118	60	24	8	18.3	14	34
5	30120-60XV	120	118	60	30	7	19.3	14	34
6	36140-80XV	140	138	80	36	11	18.52	14	34
7	24160-100XV	160	158	100	24	9	21.73	16.5	40
8	24180-120XV	180	178	120	24	9	21.61	16.5	40
9	36180-120XV	180	178	120	36	9	21.37	16.5	40
10	40180-120XV	180	178	120	40	9	21.76	16.5	40
11	24200-120XV	200	198	120	24	9	21.63	16.5	40
12	36200-120XV	200	198	120	36	11	21.52	16.5	40
13	72200-120XV	200	198	120	72	9	20.99	16.5	40
14	48210-135XV	210	208	135	48	13	21.71	16.5	40
15	60250-160XV	250	248	160	60	9	21.63	16.5	40
16	72250-160XV	250	248	160	72	11	21.42	16.5	40
17	360250-160XV	250	248	160	360	7	20.5	16.5	40
18	72280-190XV	280	278	190	72	11	21.42	16.5	40
19	360280-190XV	280	278	190	360	8	20.6	16.5	40
20	60320-210XV	320	318	210	60	11	30.46	25.5	58
21	72320-210XV	320	318	210	72	11	30.74	25.5	58
22	360320-210XV	320	318	210	360	9	29.6	25.5	58
23	48400-280XV	400	398	280	48	13	31.52	26	60
24	60400-280XV	400	398	280	60	15	31.82	26	60
25	72400-280XV	400	398	280	72	13	31.52	26	60
26	360400-280XV	400	398	280	360	13	30.6	26	60
27	48520-415XV	520	518	415	48	15	31.97	26	60
28	72520-415XV	520	518	415	72	15	31.97	26	60
29	360520-415XV	520	518	415	360	15	30.8	26	60
30	60600-480XV	600	598	480	60	15	36.95	29	70
31	72600-480XV	600	598	480	72	19	37.28	29	70
32	360600-480XV	600	598	480	360	15	36	29	70
33	72700-560XV	700	698	560	72	19	36.7	29	70
34	360700-560XV	700	698	560	360	19	36	29	70
35	721000-830XV	1000	998	830	72	22	61.7	54.5	120
36	3601000-830XV	1000	998	830	360	22	61.5	54.5	120
37	721200-1000XV	1200	1198	1000	72	22	71.7	64.5	140
38	3601200-1000XV	1200	1198	1000	360	22	71.6	64.5	140

NO.	Model NO.	Fixed bolt hole					Positioning pin hole				Withdraw bolt hole			Pitch of top end	Allowance of pitch top end
		Number of holes	P . C . D.	Hole DIA.	Top DIA.	Depth of hole	Number of pin hole	P . C . D	Angle of hole	Hole DIA.	Number of teeth hole	P . C . D	Spec. of teeth		
1	24080-44XV	6	60	M8	11	8.8	4	55	30°	2	6	60	M8x1.25	2	1.8
2	20100-40XV	6	60	6.6	11	6	3	60	30°	8	2	60	M8x1.25	1.37	1.22
3	24100-40XV	6	60	6.6	11	6	3	60	30°	8	2	60	M8x1.25	1.3	1.15
4	24120-60XV	6	80	6.6	11	6	4	80	30°	8	2	80	M8x1.25	1.3	1.15
5	30120-60XV	6	80	6.6	11	6	4	80	30°	8	2	80	M8x1.25	2.3	2
6	36140-80XV	6	100	6.6	11	6	3	100	30°	8	2	100	M8x1.25	2.5	2.2
7	24160-100XV	8	118	9	14	8	4	118	22.5°	10	2	118	M8x1.25	2.5	2.3
8	24180-120XV	8	140	9	14	8	3	140	22.5°	8	2	140	M8x1.25	1.61	1.44
9	36180-120XV	8	140	9	14	8	3	140	22.5°	8	2	140	M8x1.25	1.37	1.22
10	40180-120XV	8	140	9	14	8	3	140	22.5°	8	2	140	M8x1.25	1.76	1.57
11	24200-120XV	8	150	9	14	8	4	150	22.5°	8	2	150	M8x1.25	1.63	1.45
12	36200-120XV	8	150	9	14	8	3	150	22.5°	8	2	150	M8x1.25	1.52	1.36
13	72200-120XV	8	150	9	14	8	3	150	22.5°	8	2	150	M8x1.25	0.99	0.89
14	48210-135XV	12	165	9	14	8	3	158	15°	10	2	165	M8x1.25	1.71	1.53
15	60250-160XV	8	195	11	17.5	10	3	195	22.5°	10	2	195	M10x1.50	1.63	1.45
16	72250-160XV	8	195	11	17.5	10	3	195	22.5°	10	2	195	M10x1.50	1.42	1.27
17	360250-160XV	8	195	11	17.5	10	3	195	22.5°	10	2	195	M10x1.5	0.5	0.4
18	72280-190XV	8	222	13	20.2	12	3	222	22.5°	10	2	222	M10x1.50	1.42	1.27
19	360280-190XV	8	222	13	20.2	12	4	222	22.5°	10	2	222	M10x1.5	0.6	0.5
20	60320-210XV	10	258	13	20.2	12	4	258	18°	12	4	258	M12x1.75	1.46	1.3
21	72320-210XV	12	258	13	20.2	12	3	258	15°	12	4	258	M12x1.75	1.74	1.55
22	360320-210XV	12	258	13	20.2	12	3	258	15°	12	4	258	M12x1.75	0.6	0.5
23	48400-280XV	12	335	13	20.2	12	3	335	15°	12	4	335	M12x1.75	1.52	1.36
24	60400-280XV	12	335	13	20.2	12	3	335	15°	12	4	335	M12x1.75	1.82	1.62
25	72400-280XV	12	335	13	20.2	12	3	335	15°	12	4	335	M12x1.75	1.52	1.36
26	360400-280XV	12	335	13	20	12	3	335	15°	12	4	335	M12x1.75	0.6	0.5
27	48520-415XV	12	450	13	20.2	12	3	450	15°	12	4	450	M12x1.75	1.97	1.76
28	72520-415XV	12	450	13	20.2	12	3	450	15°	12	4	450	M12x1.75	1.97	1.76
29	360520-415XV	12	450	13	20.2	12	3	450	15°	12	4	450	M12x1.75	0.8	0.7
30	60600-480XV	12	530	17	26	16	4	530	15°	12	4	530	M12x1.75	1.95	1.74
31	72600-480XV	12	530	17	26	16	3	530	15°	12	4	530	M12x1.75	2.28	2.04
32	360600-480XV	12	530	17	26	16	3	530	15°	12	4	530	M12x1.75	1	0.9
33	72700-560XV	12	610	17	26	16	3	610	15°	14	4	610	M12x1.75	1.7	1.5
34	360700-560XV	12	610	17	26	16	3	610	15°	14	4	610	M12x1.75	1	0.9
35	721000-830XV	18	900	17	26	16	4	900	10°	-	4	900	M12x1.75	1.7	1.5
36	3601000-830XV	18	900	17	26	16	4	900	10°	-	4	900	M12x1.75	1.75	1.4
37	721200-1000XV	20	1080	21	32	20	4	1080	9°	-	4	1080	M16x2.00	1.7	1.5
38	3601200-1000XV	20	1080	21	32	20	4	1080	9°	-	4	1080	M16x2.00	1.6	1.5



- Compact design with larger machine-able work space
- Combination of case hardened special alloy screw and special high tensile strength brass worm wheel ensures exceptional wear resistant and long durability.
- Dual lead worm screw for easy backlash adjustment
- Large diameter worm wheel for extra rigidity, smoothness and torque transfer efficiency
- Double bearing design and solid one piece face plate & spindle for extra rigidity
- Available as :
 - o Integrated 5th axis
 - o Integrated 4th axis + programmable controller on tilt axis
 - o Indexer with programmable control boxes on rotary and tilt axis
 - o Optional air purge for water protection
 - o Super high resolution with optional rotary scale

Model	AX5-100		AX5-200		AX5-250		AX5-320		
Table Diameter	120mm	4.72"	200mm	7.87"	250mm	9.84"	320mm	12.6"	
Center Height	150mm	5.91"	195mm	7.68"	225mm	8.86"	255mm	10.04"	
Center Hole	30mm H7	1.18" H7	35mm H7	1.38" H7	70mm H7	2.76" H7	110mm H7	4.33" H7	
Guide Block Width	14mm h7	0.55" h7	18mm h7	0.71" h7	18mm h7	0.71" h7	18mm h7	0.71" h7	
T-slot Width	10mm H7	0.39" H7	12mm H7	0.47" H7	12mm H7	0.47" H7	14mm H7	0.55" H7	
FANUC servo motor	Rotating	Tilting	Rotating	Tilting	Rotating	Tilting	Rotating	Tilting	
	aiF2	aiF2	aiF4	aiF8	aiF4	aiF8	aiF8	aiF12	
Tilting degree	-20°~120°		-110°~110°		-110°~110°		-110°~110°		
Max. RPM	27.8	16.7	22.2	11.1	22.1	11.1	11.1	11.1	
Gear Ratio	1:72	1:120	1:90	1:180	1:90	1:180	1:180	1:180	
Indexing Accuracy arc sec.	± 17.5	± 30	± 15	± 30	± 10	± 30	± 10	± 15	
Net Weight without motors	105kg	232lbs	240kg	530lbs	280kg	617lbs	505kg	1,111lbs	
Clamp Torque (Pneumatic @72psi)	Rotary Axis	118Nm	87ft-lbs	245Nm	181ft-lbs	490Nm	361ft-lbs	696Nm	516ft-lbs
	Tilt Axis	118Nm	87ft-lbs	245Nm	181ft-lbs	490Nm	361ft-lbs	696Nm	516ft-lbs
Clamp Torque (Hydraulic @286psi)	Rotary Axis	235Nm	173ft-lbs	490Nm	361ft-lbs	980Nm	722ft-lbs	1,392Nm	1,026ft-lbs
	Tilt Axis	235Nm	173ft-lbs	490Nm	361ft-lbs	1,176Nm	867ft-lbs	1,392Nm	1,026ft-lbs
Max Weight Limit @ 0 deg	35kg	77lbs	100kg	220lbs	100kg	220lbs	200kg	440lbs	
Max Weight Limit @ 90 deg	20kg	44lbs	50kg	110lbs	60kg	132lbs	100kg	220lbs	
Horizontal Load Limit		3,920 N	881lbf	4,900 N	1,101lbf	11,760 N	2,644lbf	14,700 N	3,305lbf
Circumference Load Limit		118Nm	87ft-lbs	245Nm	181ft-lbs	490Nm	362ft-lbs	696Nm	516ft-lbs
Vertical Load Limit		98Nm	73ft-lbs	147Nm	110ft-lbs	255Nm	188ft-lbs	343Nm	253ft-lbs

* All specifications are subject to change without prior notice.

AX5-100

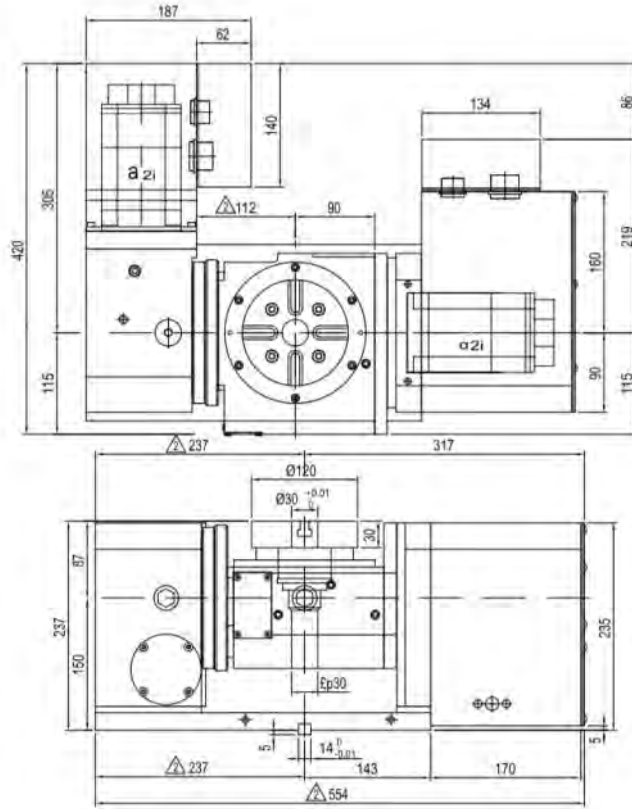

AX5-200

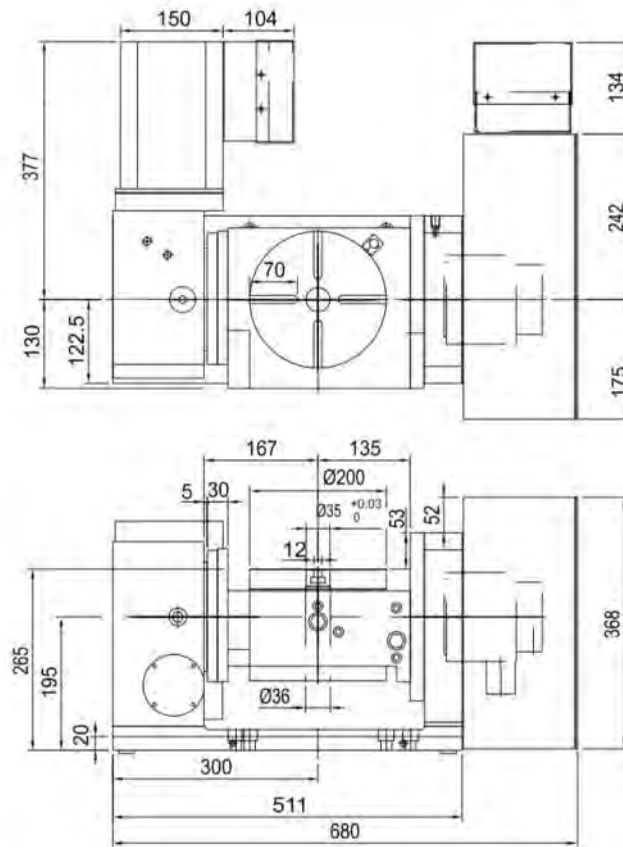

AX5-250

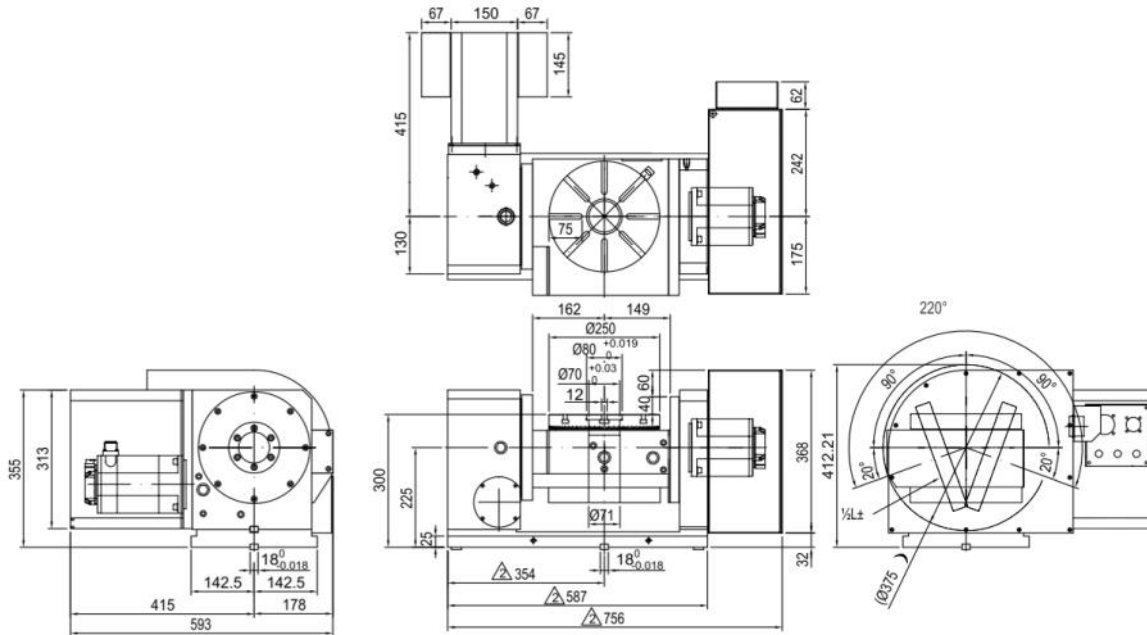

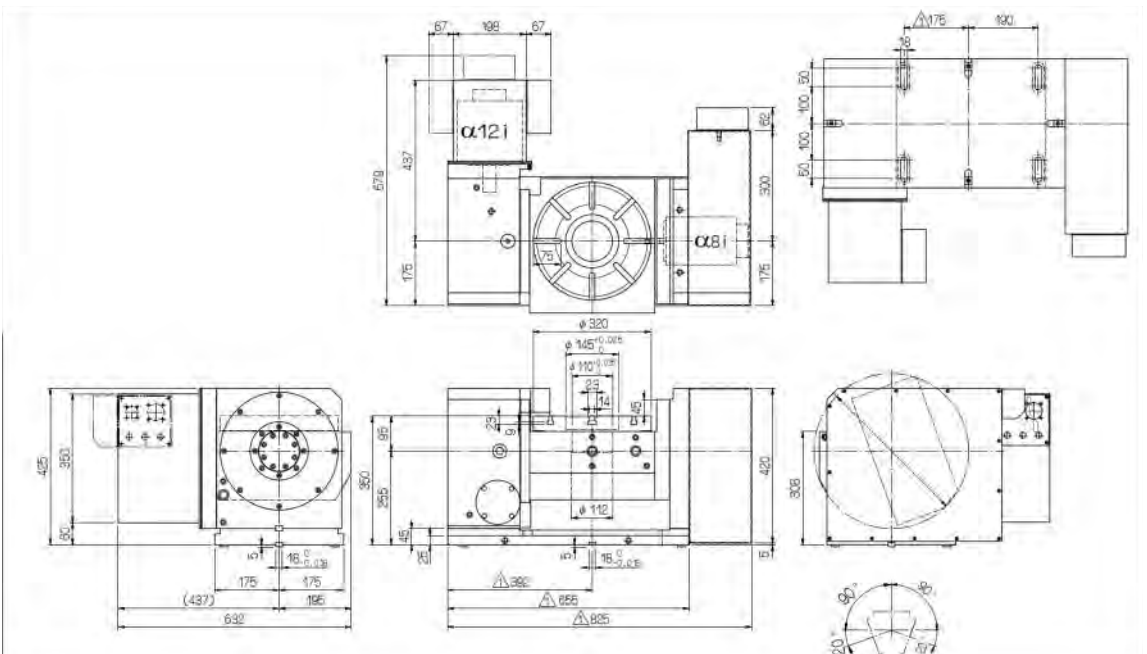

AX5-320

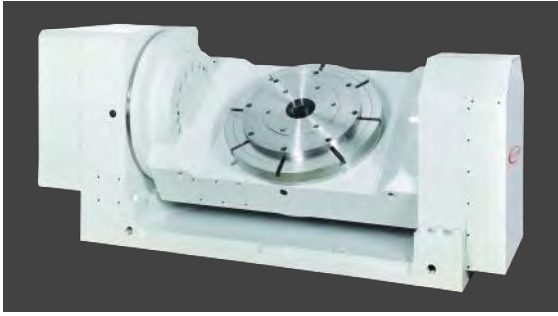

Trunnion Models AX5-320T, 450, 630, 800



- Compact design with wide machining range.
- Up to 1 meter table M/C install available upon request
- Easy installation & operation.
- Compact design with wide machining range.
- Even an approx. 1 Meter Table M/C can be installed.
- To match 5 axis M/C for continuous machining, the tilting axis can connect to the M-code by using our single axis AC/DC/Stepping servo controller.

Model	AX5-320SW		AX5-450		AX5-630		AX5-800		
Table Diameter	320mm	12.6"	450mm	17.72"	630mm	24.8"	800mm	31.5"	
Center Height	375mm	14.76"	440mm	17.32"	580mm	22.83"	650mm	25.59"	
Center Hole	145mm H7	5.71" H7	150mm H7	5.91" H7	254mm H7	10.0" H7	254mm H7	10.0" H7	
Guide Block Width	18mm h7	0.71" h7	18mm h7	0.71" h7	22mm h7	0.87" h7	22mm h7	0.87" h7	
T-slot Width	14mm H7	0.55" H7	14mm H7	0.55" H7	18mm H7	0.71" H7	20mm H7	0.79" H7	
FANUC servo motor	Rotating	Tilting	Rotating	Tilting	Rotating	Tilting	Rotating	Tilting	
	aiF8	aiF22	aiF12	aiF22	aiF22	aiF22	aiF22	aiF30	
Tilting degree	±120°		±120°		±120°		±120°		
Max. RPM	11.1	11.1	22.2	11.1	11.1	5.8	11.1	2.8	
Gear Ratio	1:180	1:180	1:90	1:180	1:180	1:360	1:180	1:720	
Indexing Accuracy arc sec.	± 10	± 15	± 7.5	± 15	± 7.5	± 15	± 7.5	± 10	
Net Weight without motors	855kg	1,881lbs	1,160kg	2,552lbs	2,650kg	5,830lbs	4,850kg	10,670lbs	
Clamp Torque (Pneumatic @72psi)	Rotary Axis	696Nm	513ft-lbs	882Nm	650ft-lbs	3,430Nm	2,529ft-lbs	-	-
	Tilt Axis	931Nm	687ft-lbs	1,176Nm	867ft-lbs	4,116Nm	3,035ft-lbs	-	-
Clamp Torque (Hydraulic @286psi)	Rotary Axis	1,391Nm	1,026Nm	1,764Nm	1,301ft-lbs	6,860Nm	5,059ft-lbs	9,800Nm	7,227ft-lbs
	Tilt Axis	1,862Nm	1,373ft-lbs	2,058Nm	1,518ft-lbs	7,840Nm	5,782ft-lbs	12,250Nm	9,034ft-lbs
Max Weight Limit @ 0 deg	200kg	440lbs	300kg	660lbs	500kg	1,100lbs	1,000kg	2,200lbs	
Max Weight Limit @ 90 deg	100kg	220lbs	150kg	330lbs	300kg	660lbs	600kg	1,320lbs	
Horizontal Load Limit		14,700 N	3,305lbf	17,640 N	3,965lbf	20,384 N	4,582lbf	25,480 N	5,728lbf
Circumference Load Force		696Nm	513ft-lb	882Nm	650ft-lb	3,430Nm	2,529ft-lb	9,800Nm	7,227ft-lb
Vertical Load Limit		343Nm	253ft-lb	490Nm	361ft-lb	2,234Nm	1,648ft-lb	2,793Nm	2,060ft-lb

* All specifications are subject to change without prior notice.

AX5-320T

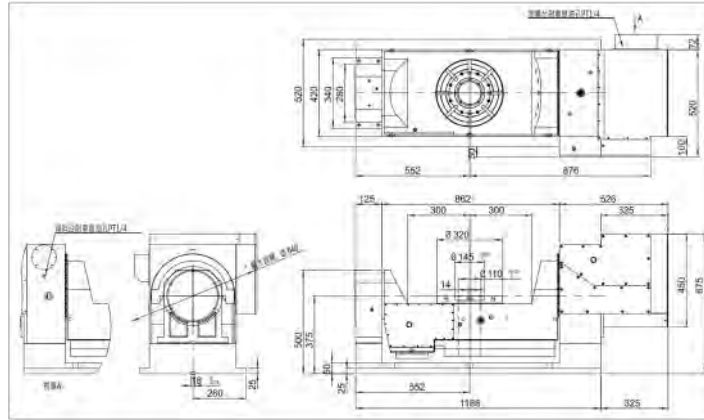

AX5-450

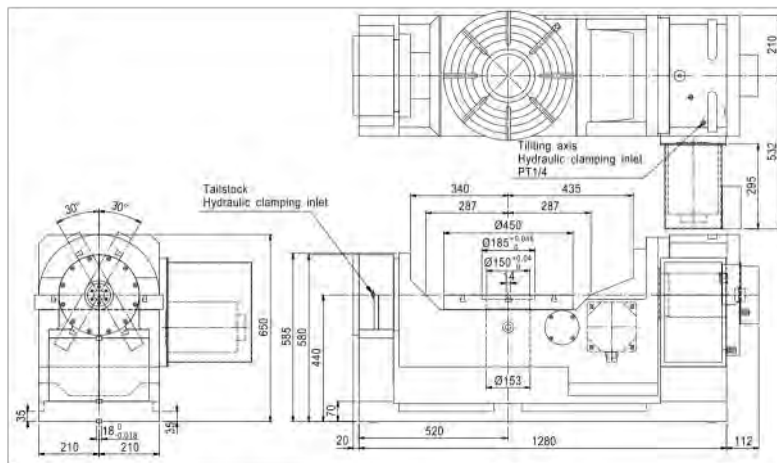

AX5-630

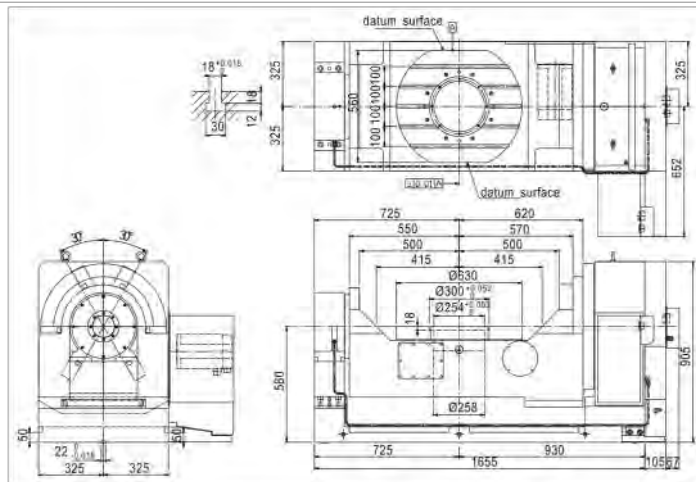

AX5-800

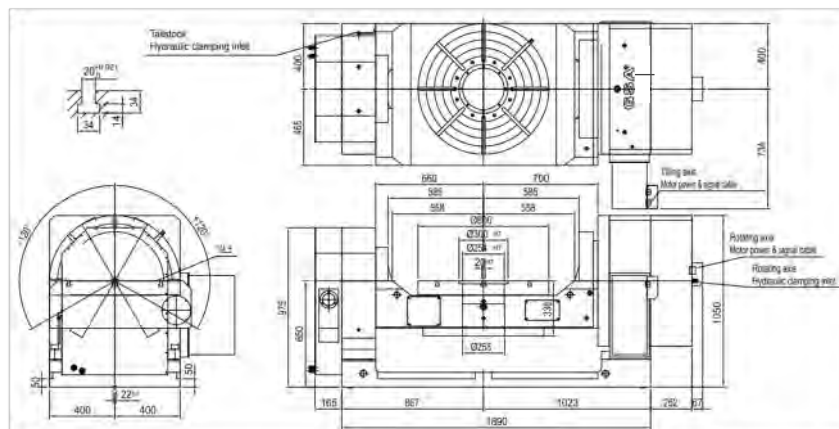

Manual-Tilting Rotary Table AX4MT-200, 250, 320, 400, 500, 630

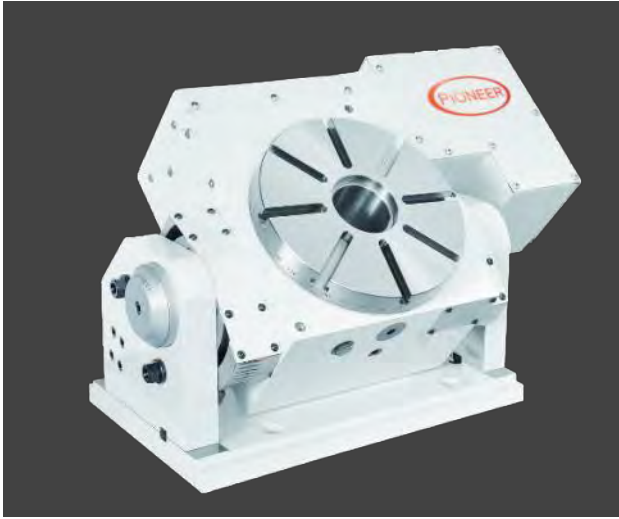

- Suitable for conventional milling, boring, and tapping machine.
- Manual tilting, Rotating by AX control.
- Available as Indexer or 4th Axis Installation.

Model	AX4MT-200		AX4MT-250		AX4MT-320		AX4MT-400		AX4MT-500		AX4MT-630	
Table Diameter	200mm	7.87"	250mm	9.84"	320mm	12.6"	400mm	15.75"	500mm	19.69"	630mm	24.8"
Center Height	190mm	7.48"	210mm	8.27"	270mm	10.63"	290mm	11.42"	330mm	13.0"	440mm	17.32"
Center Hole	30mm H7	1.18" H7	70mm H7	2.76" H7	110mm H7	4.33" H7	150mm H7	5.91" H7	180mm H7	7.09" H7	254mm H7	10.0" H7
Guide Block Width	18mm h7	0.71" h7	18mm h7	0.71" h7	18mm h7	0.71" h7	18mm h7	0.71" h7	18mm h7	0.71" h7	18mm h7	0.71" h7
T-slot Width	12mm H7	0.47" H7	12mm H7	0.47" H7	14mm H7	0.55" H7	14mm H7	0.55" H7	18mm H7	0.71" H7	18mm H7	0.71" H7
FANUC servo motor	R-axis	T-axis	R-axis	T-axis	R-axis	T-axis	R-axis	T-axis	R-axis	T-axis	R-axis	T-axis
	aiF4	Manual	aiF4	Manual	aiF12	Manual	aiF12	Manual	aiF12	Manual	aiF22	Manual
Tilting degree	0°~105°		0°~100°		0°~100°		0°~100°		0°~100°		0°~100°	
Max. RPM	22.2		22.2		22.2/11.1		22.2		16.7		11.1	
Gear Ratio	1:90		1:90		1:90/1:180		1:90		1:120		1:180	
Indexing Accuracy arc sec.	± 10 seconds		± 10 seconds		± 10 seconds		± 10 seconds		± 10 seconds		± 10 seconds	
Net Weight without motors	135kg	297lbs	220kg	484lbs	310kg	682lbs	380kg	836lbs	450kg	990lbs	1000kg	2200lbs
Clamp Torque Rotate Axis	Pneumatic @72psi		461Nm		696Nm		902Nm		1,125Nm		3,626Nm	
	Hydraulic @286psi		921Nm		1,392Nm		1,803Nm		2,450Nm		7,252Nm	
Vertical Weight Limit	40kg	88lbs	125kg	275lbs	150kg	330lbs	300kg	660lbs	350kg	770lbs	500kg	1100lbs
Horizontal Weight Limit	80kg	176lbs	300kg	660lbs	350kg	770lbs	500kg	1100lbs	600kg	1320lbs	1000kg	2200lbs
Horizontal Load Limit	5880 N	1,322lbf	11,838 N	2661lbf	13,475 N	3,030lbf	15,533 N	3,492lbf	18,424 N	4141lbf	20,384 N	4,582lbf
Circumference Load Limit	245Nm	181ft-lbs	461Nm	340ft-lbs	696Nm	514ft-lbs	902Nm	665ft-lbs	1,125Nm	903ft-lbs	3,626Nm	2,674ft-lbs
Vertical Load Limit	196Nm	145ft-lbs	706Nm	520ft-lbs	902Nm	665ft-lbs	980Nm	723ft-lbs	1,617Nm	1,192ft-lbs	2,234Nm	1,648ft-lbs

* All specifications are subject to change without prior notice.

AX4MT-200

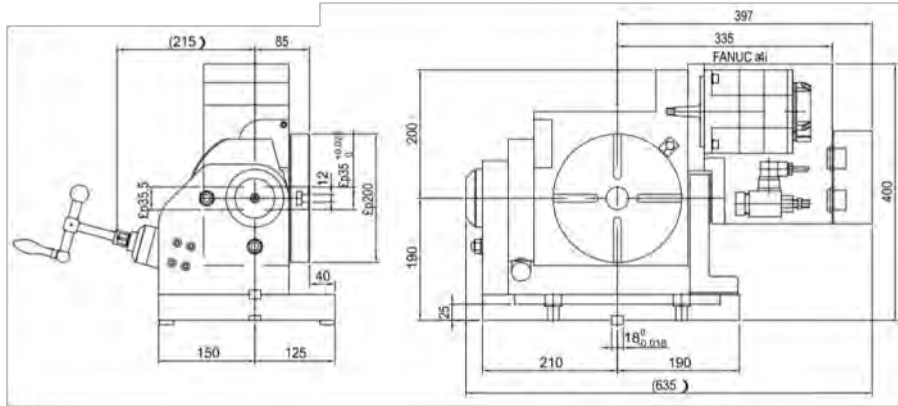

AX4MT-250

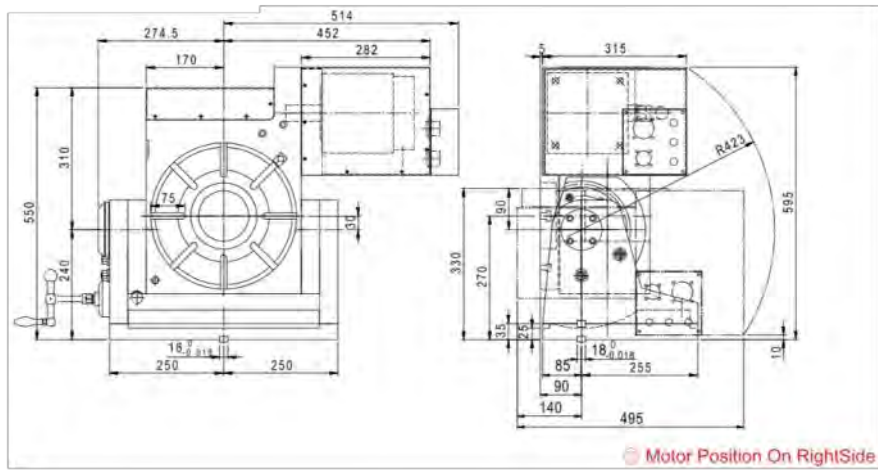

AX4MT-320

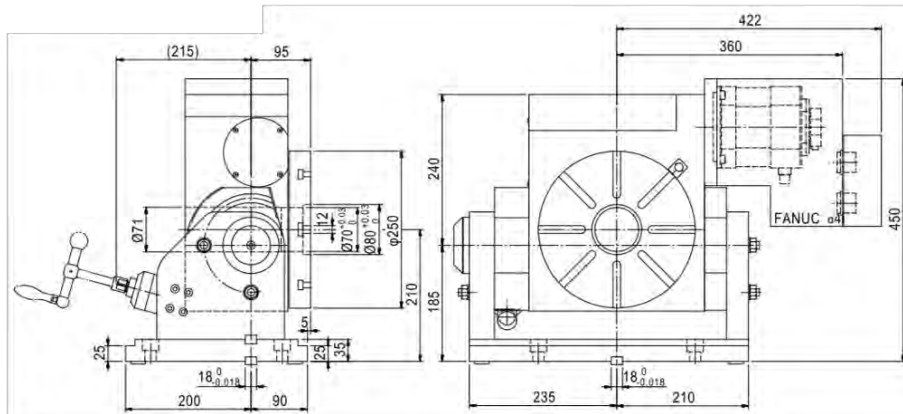

Manual-Tilting Rotary Table AX4MT-200, 250, 320, 400, 500, 630

AX4MT-320

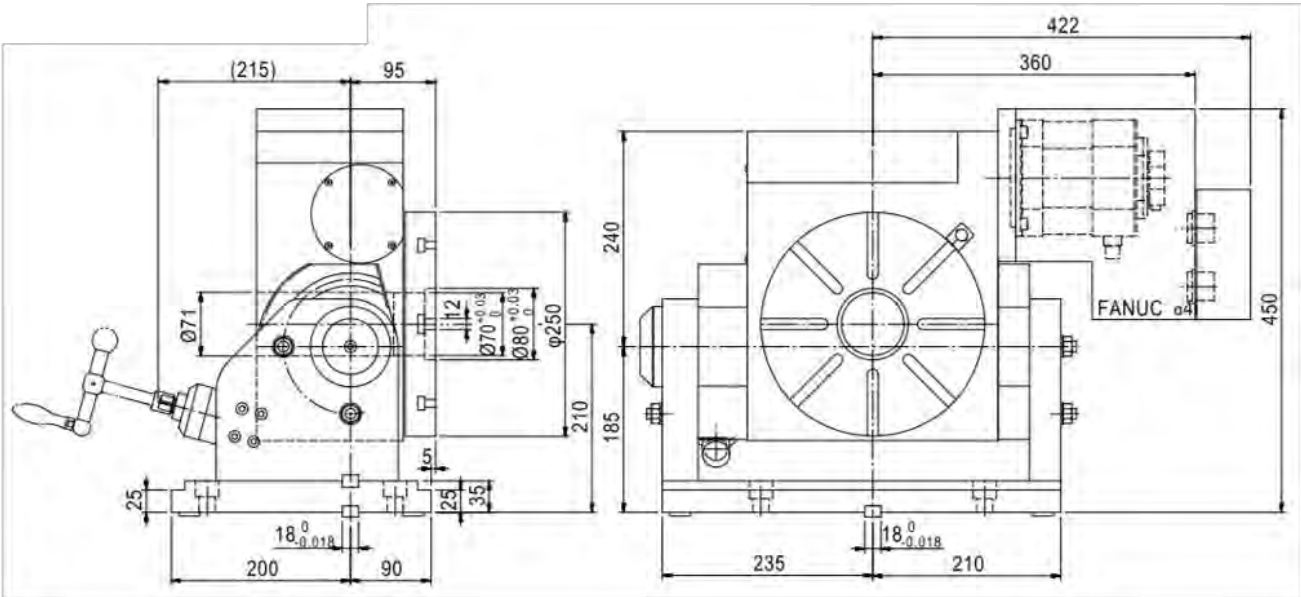

AX4MT-400

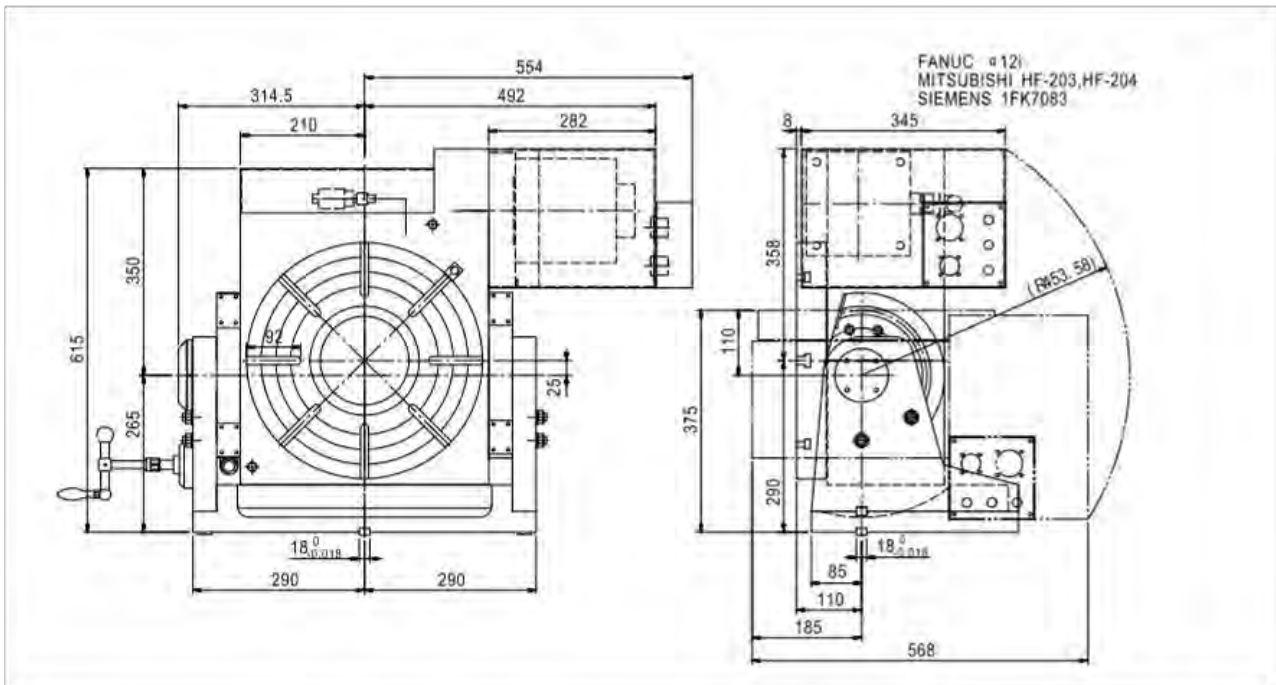

AX4MT-630

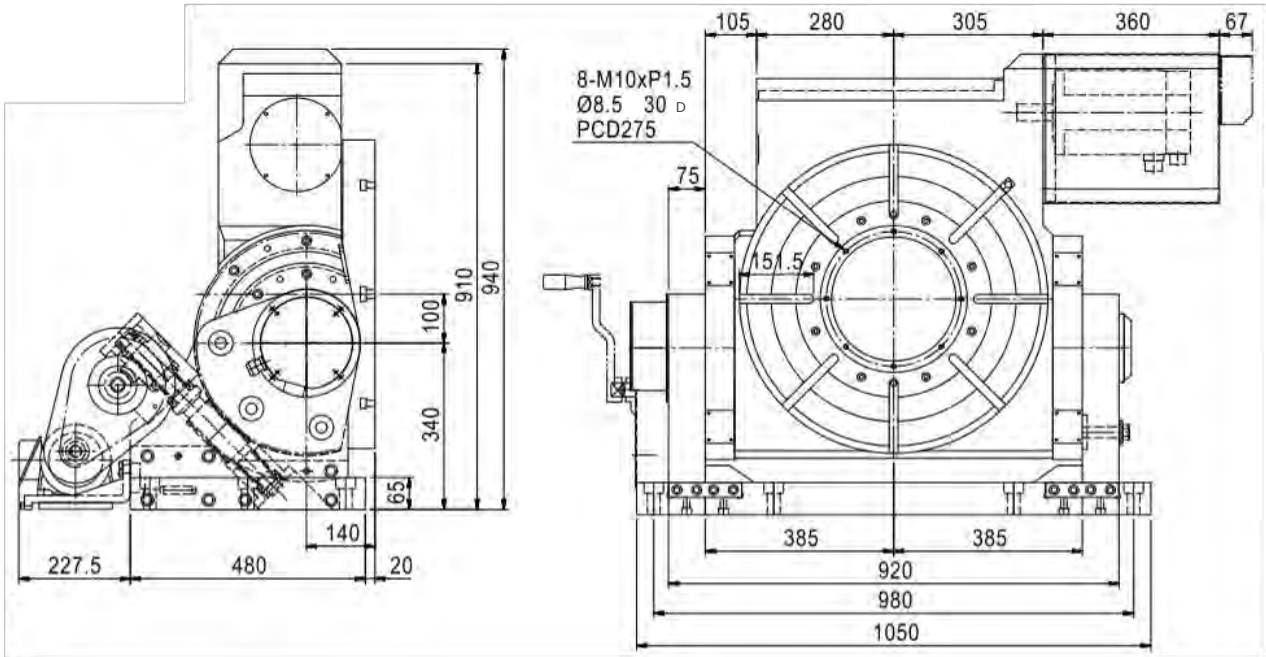

Horizontal Rotary/Index Center Table HIT-400, 500, 630, 800

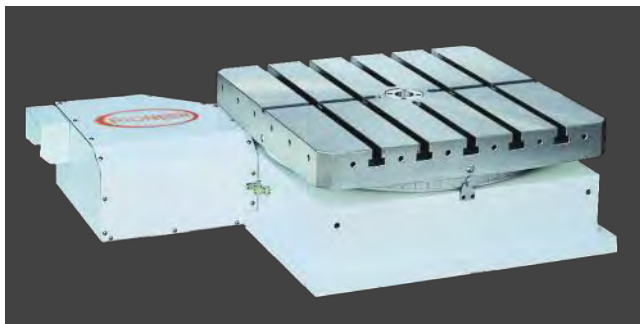

- Suitable for horizontal machining center.
- Rotating speed can reach up to 33.3 RPM.
- Special anti-wearing/rigid alloy of bronze/nickel worm wheel and hardened steel worm screw ensure long term indexing accuracy.
- Twice as powerful brake system with large size clamping contact surface suitable for heavy cutting
- 2 or 3 pieces hirth coupling for positioning, repeatability can be reached +/- 0.5 sec. Accuracy will not be changed even with long operation times.
- Indexing accuracy can be specified to customer's requirement: +/-2sec. Or +/-3sec.

Model		HIT-400		HIT-500	
Table Size LxW		400x400mm	15.75x15.75"	500x500mm	19.69x19.69"
Overall height		310mm	12.20"	310mm	12.20"
Center Hole Diameter.		30mm H7	1.18" H7	30mm H7	1.18" H7
T-slot size		14mm H7	0.55" H7	14mm H7	0.55" H7
Rotating direction		CW/CCW			
Drive power	Hydraulic Clamping/unclamping	20kg/cm2			
	Revolving (servo motor type) [FANUC]	aiF12		aiF12 / aiF22	
Gear Ratio		1:90		1:120	
Max. RPM		22.2		16.7	
Main. Increment Degree		1° or 5°			
Max. loading weight		500kg	1,100lbs	500kg	1,100lbs
Clamping force (evenly distributed)		3,300kg	7,260lbs	3,700kg	8,140lbs
Lifting distance during clamp/unclamp		0			
Weight		325kg	715lbs	360kg	792lbs
Indexing Accuracy arc sec.		± 5 seconds			

Model		HIT-630		HIT-800	
Table Size LxW		630x630mm	24.8x24.8"	800x800mm	31.5x31.5"
Overall height		285mm	11.22"	360mm	14.17"
Center Hole Diameter.		40mm H7	1.57" H7	55mm H7	2.17" H7
T-slot size		20mm H7	0.79" H7	22mm H7	0.87" H7
Rotating direction		CW/CCW			
Drive power	Hydraulic Clamping/unclamping	25kg/cm2		35kg/cm2	
	Revolving (servo motor type) [FANUC]	a22 i			
Gear Ratio		1:180			
Max. RPM		11.1			
Main. Increment Degree		1° or 5°		1°	
Max. loading weight		2,500kg	5,500lbs	3,000kg	6,600lbs
Clamping force (evenly distributed)		4,000kg	8,800lbs	7,000kg	15,400lbs
Lifting distance during clamp/unclamp		0			
Weight		525kg	1,155lbs	1,360kg	2,992lbs
Indexing Accuracy arc sec.		± 5 seconds			

* All specifications are subject to change without prior notice.

HIT-400

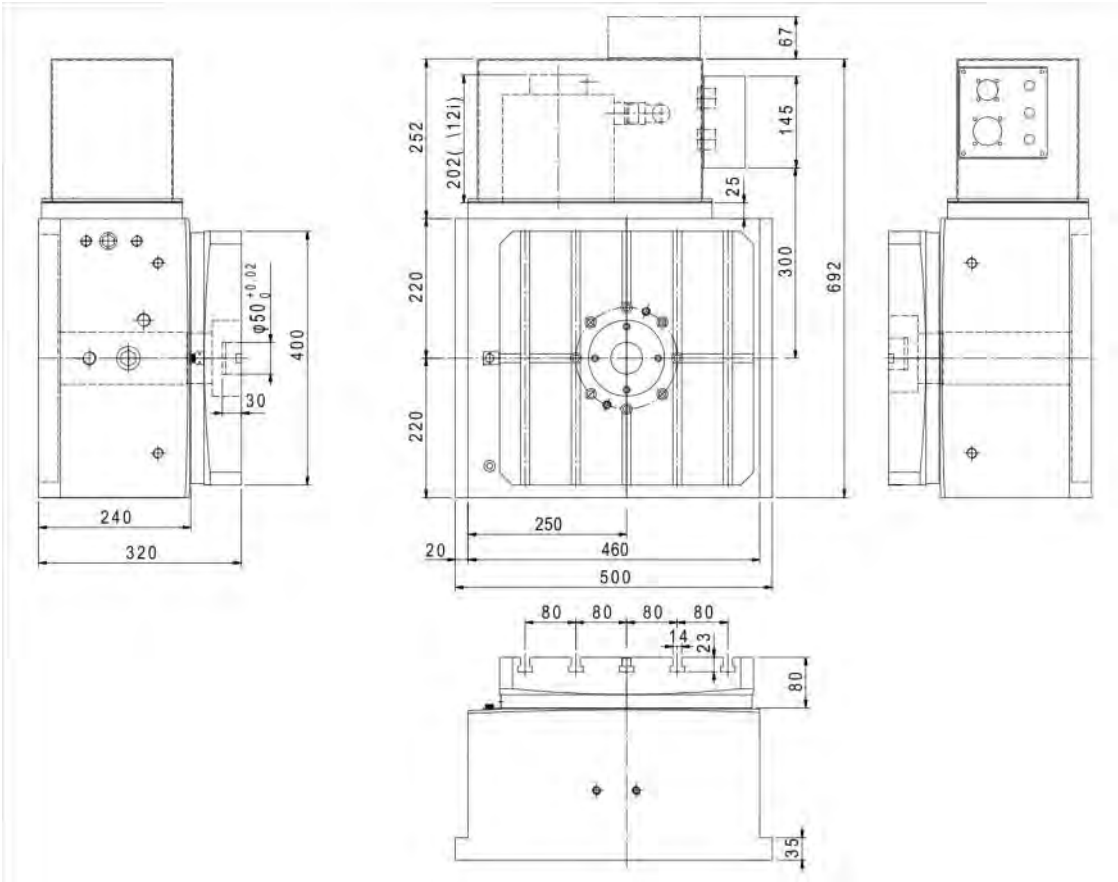

HIT-500

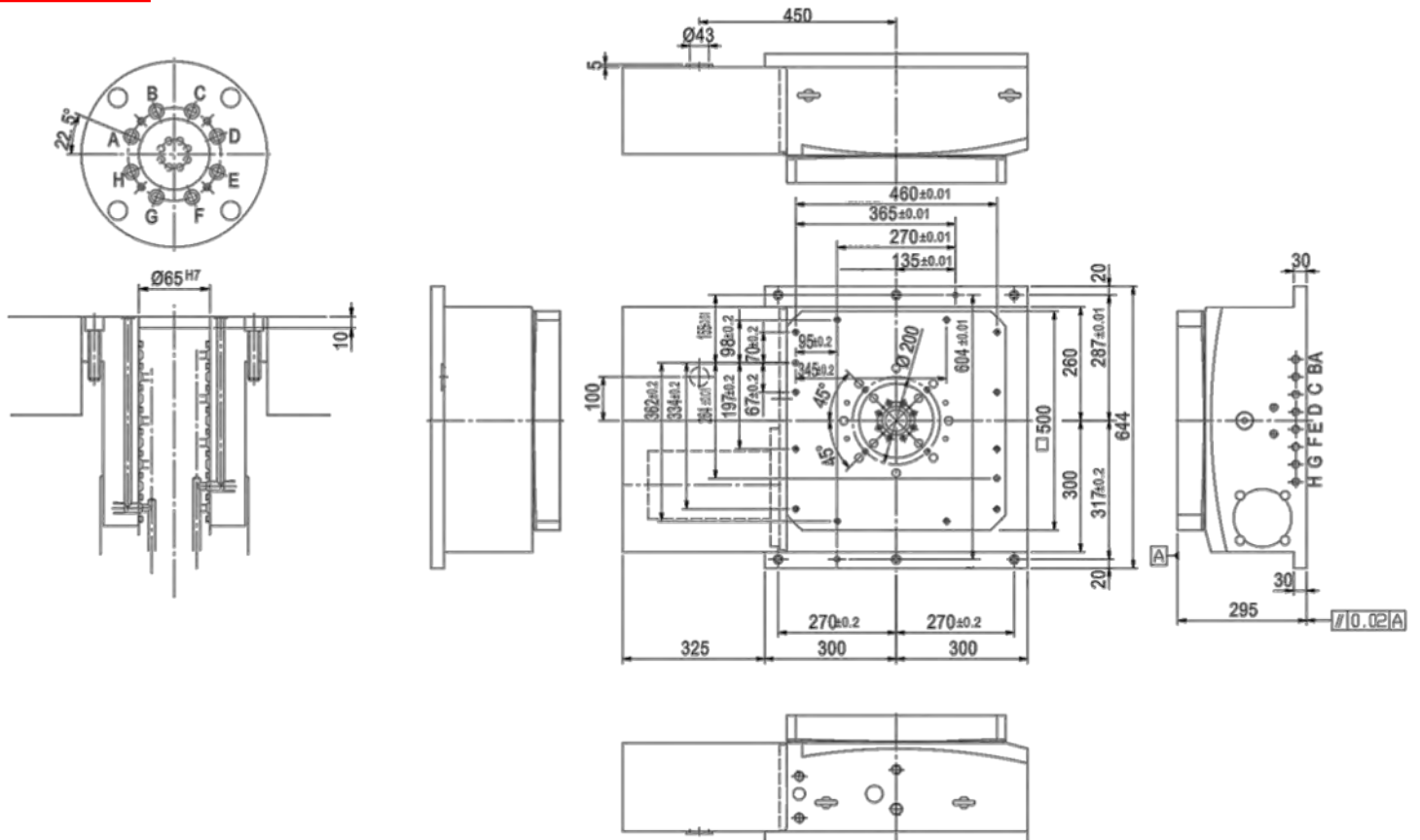

HIT630

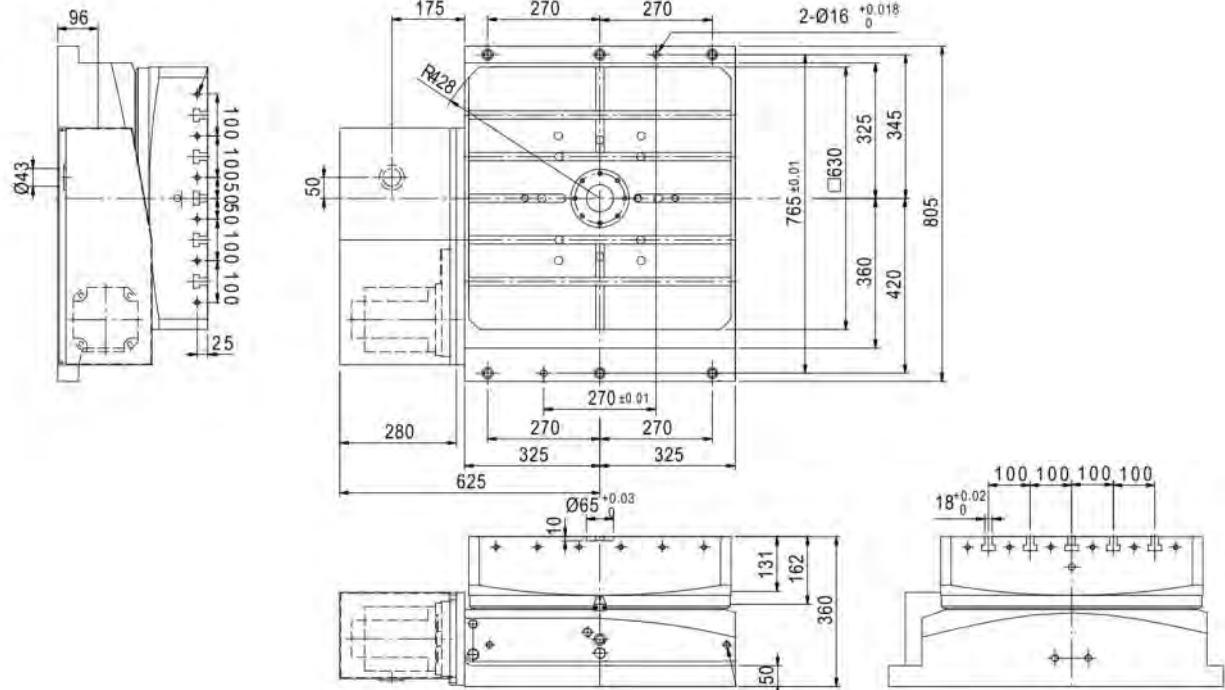

HIT-800

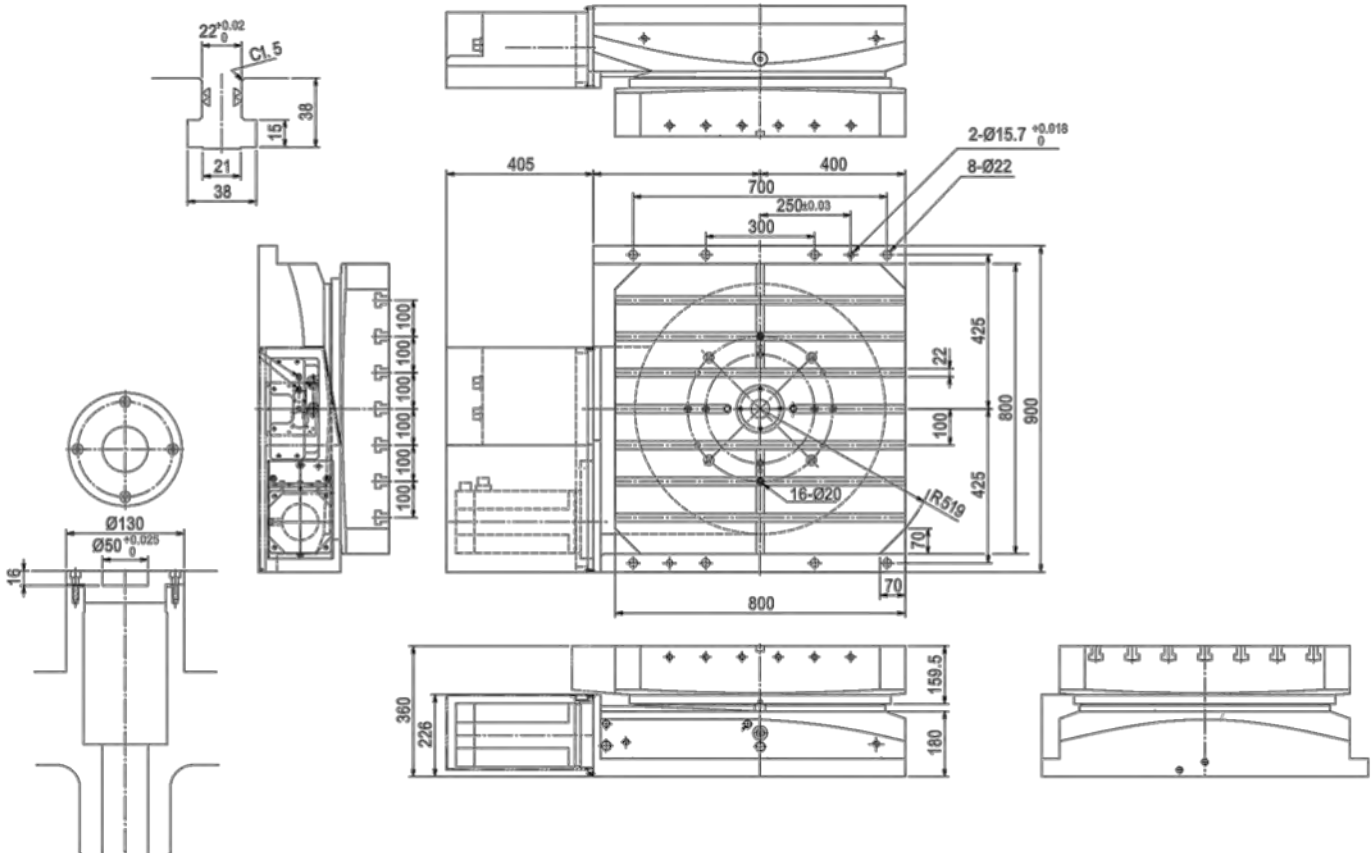

Large size horizontal AX Rotary Table HRT-400, 500, 630, 800, 1000, 1500, 2000, 2500

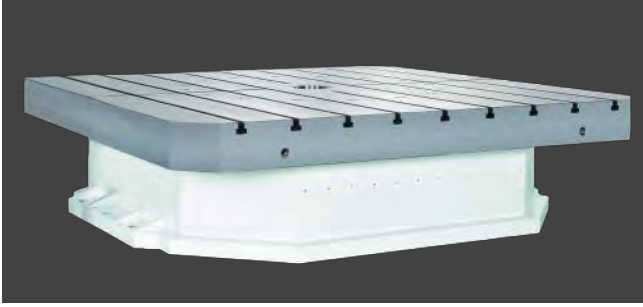

- Suitable for horizontal machining center, floor type boring machine.
- For both indexing & simultaneous machine.
- Hi-accuracy: Special anti-wearing/rigid alloy of bronze/nickel worm wheel and hardened steel worm screw ensure long term indexing accuracy.
- Can be manufactured according to customer's design and interface of machine saddle.
- Hydraulic clamping & high rigid brake structure for heavy cutting.
- Table sizes from 400mm to 2,500mm or even custom size for special requirements
- High loading/accuracy design available, suitable for heavy machining and metrology applications
- Built-in hydraulic ports system suitable for special machine of horizontal machining center and automobile/motorbike industrial.
- Random dividing 0.001 degrees, Indexing accuracy according to customer's requirement 6 sec, 10 sec, or higher indexing accuracy. (Encoder is required)

Model	HRT-400		HRT-500		HRT-630		HRT-800	
Table Size	400mm	15.75"	500mm	19.69"	630mm	24.8"	800mm	31.5"
T-slots size	14mm	0.55"	14mm	0.55"	18mm	0.71"	22mm	0.87"
Table Swing Diameter	500mm	19.69"	660mm	25.98"	800mm	31.5"	1040mm	40.94"
Total Height	310mm	12.2"	295mm	11.61"	360mm	14.17"	385mm	15.16"
Max. Loading (evenly distributed)	500kg	1,100lbs	600kg	1,320lbs	1,200kg	2,640lbs	2,000kg	4,400lbs
Vertical Max. Force	1,585kg	3,487lbs	1,880kg	4,136lbs	2,080kg	4,576lbs	2,080kg	4,576lbs
Load Capacity During Rotation	102kg/cm ²		191kg/cm ²		405kg/cm ²		816kg/cm ²	
Clamping Force	3,500kg	7,700lbs	5,500kg	12,100lbs	6,500kg	14,300lbs	7,000kg	15,400lbs
Machining Torque	1,196Nm	882ft-lbs	2,254Nm	1,662ft-lbs	3,234Nm	2,384ft-lbs	3,430Nm	2,529ft-lbs
Parallelism of table top & frame bottom	0.015mm	0.00059	0.015mm	0.00059	0.025mm	0.00098	0.03mm	0.0012
Repeatability	± 4 seconds							
FANUC servo motor	aiF12		aiF12 / aiF22		aiF22		aiF22	

* All specifications can be modified according to customer's requirement

- To match servo type: Refer to P (HIT series)

HRT-400

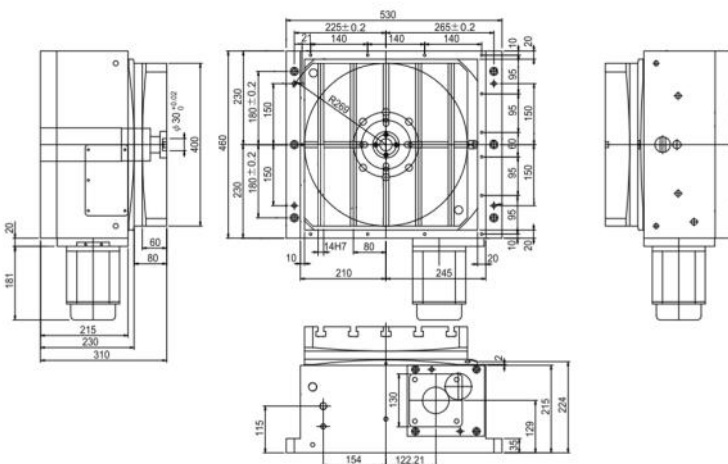

HRT-800

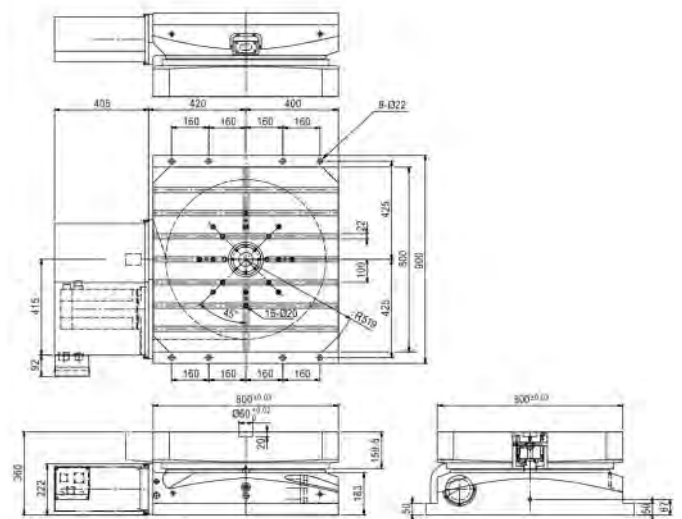

Large size horizontal AX Rotary Table HRT-400, 500, 630, 800, 1000, 1500, 2000, 2500

AXIAL-RADIAL ROLLER BEARING SERIES

Model	HRT-1000		HRT-1500		HRT-2000		HRT-2500	
Table Size	ø1000mm □1000x1000mm		ø1500mm □1500x1500mm		ø2000mm □2000x2000mm		ø2500mm □2500x2500mm	
	ø39.37" □39.37x39.37"		ø59.06" □59.06x59.06"		ø78.74" □78.74x78.74"		ø98.43" □98.43x98.43"	
T-slots size	22mm	0.87"	28mm	1.10"	28mm	1.10"	32mm	1.26"
Table Swing Diameter.	ø1000mm □1300mm		ø1500mm □1950mm		ø2000mm □2600mm		ø2500mm □3200mm	
	ø39.37" □51.18"		ø59.06" □76.77"		ø78.74" □102.36"		ø98.43" □125.98"	
Total Height	450mm	17.72"	530mm	20.87"	600mm	23.62"	600mm	23.62"
Max. Loading	5,000kg	11,000lbs	15,000kg	33,000lbs	20,000kg	44,000lbs	30,000kg	66,000lbs
Indexing Accuracy arc sec.	A6" B10"							
Repeatability	± 4 seconds							
Clamping Force	5000kg	11000lbs	15000kg	33000lbs	20000kg	44000lbs	30000kg	66000lbs
Machining Torque	2,942Nm	2,168ft-lbs	6,860Nm	5,059ft-lbs	8,820Nm	6,504ft-lbs	15,680Nm	11,563ft-lbs
Parallelism of table top &	0.01/300mm							
Gear Ratio	1:360				1:720			
FANUC servo motor	αiF22				αiF30			

* All specifications can be modified according to customer's requirement

HRT-1000

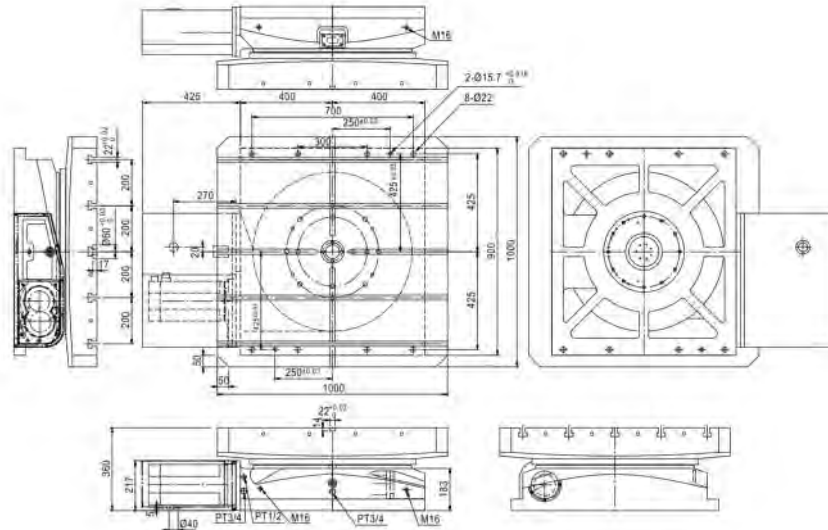

HRT-1200

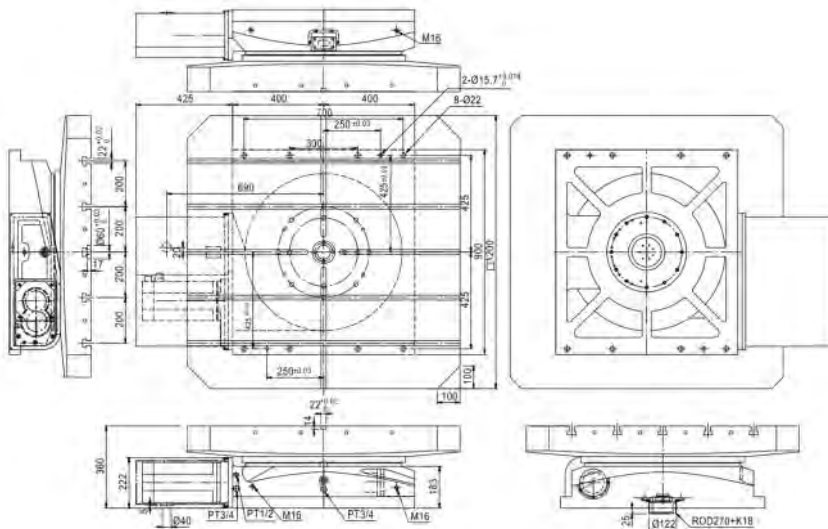

Precision Index Table GCT-301, 450, 600, 700, 800, 1000, 1200

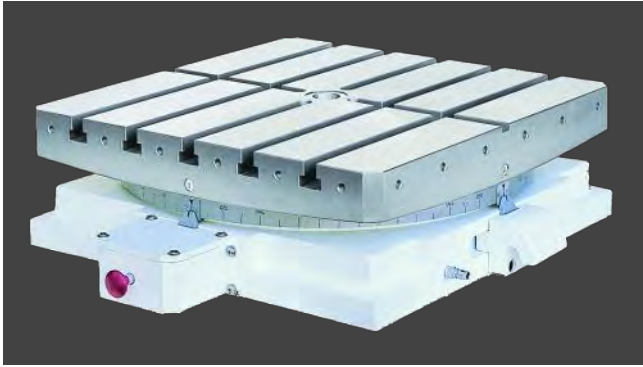

- Suitable for high accuracy machining such as boring, milling, grinding, etc.
- Built-in 2 piece hirth coupling for positioning, indexing accuracy +/- 3 sec. ensures long-term operation.
- Powerful clamping design allows heavy cutting and boring.
- Clamping/Unclamping by easy pneumatic operation.
- Body material is FC-35 cast iron, durable and will last longer without deformation.

Model	GCT-301	GCT-450	GCT-600	GCT-700	GCT-800	GCT-1000	GCT-1200
Table size L x W	300X300mm	450X450mm	600X600mm	700X700mm	800X800mm	1000X1000mm	1200X1200mm
	11.81X11.81"	17.72X17.72"	23.62X23.62"	27.56X27.56"	31.5X31.5"	39.37X39.37"	47.24X47.24"
Height	140mm	170mm	200mm	220mm	280mm	300mm	340mm
	5.51"	6.69"	7.87"	8.66"	11.02"	11.81"	13.39"
Spindle hole	ø30mm	ø30mm	ø40mm	ø40mm	ø60mm	ø60mm	ø80mm
	1.18"	1.18"	1.57"	1.57"	2.36"	2.36"	3.15"
T-slot	12mm	18mm	20mm	20mm	22mm	22mm	22mm
	0.47"	0.71"	0.79"	0.79"	0.87"	0.87"	0.87"
Table rotating	clockwise and counterclockwise						
Table lifting up & clamp down stroke	5mm / 0.2"				8mm / 0.31"		
Driving	Longitudinal	Air Pressure 5-8 kg/cm ²					
	Revolving	Manual					
Number of division (evenly distributed)	15°	1° or 5°					
Max. load weight in theory	1200kg	2400kg	3400kg	3400kg	4500kg	6000kg	7000kg
	2640lbs	5280lbs	7480lbs	7480lbs	9900lbs	13200lbs	15400lbs
Allowable load weight	500kg	1000kg	2000kg	2000kg	3000kg	5000kg	6000kg
	1100lbs	2200lbs	4400lbs	4400lbs	6600lbs	11000lbs	13200lbs
Clamping capacity	-	2200kg	3200kg	3200kg	5400kg	5400kg	8100kg
	-	4840lbs	7040lbs	7040lbs	11880lbs	11880lbs	17820lbs
Net Weight	90kg	200kg	400kg	600kg	900kg	1200kg	2000kg
	198lbs	440lbs	880lbs	1320lbs	1980lbs	2640lbs	4400lbs

* All specifications are subject to change without prior notice.

Precision Index Table GCT-301, 450, 600, 700, 800, 1000, 1200

GCT-301 - 12000

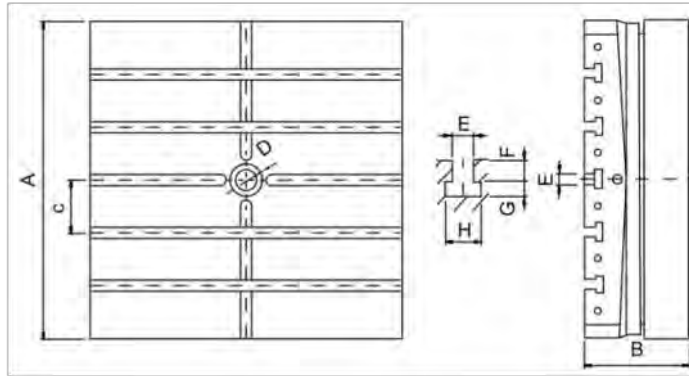

	GCT-301		GCT-450		GCT-600		GCT-700		GCT-800		GCT-1000		GCT-1200	
A	300mm	11.81"	450mm	17.72"	600mm	23.62"	700mm	27.56"	800mm	31.50"	1000mm	39.37"	1200mm	47.24"
B	140mm	5.51"	170mm	6.69"	200mm	7.87"	220mm	8.66"	280mm	11.02"	300mm	11.81"	340mm	13.39"
C	100mm	3.94"	100mm	3.94"	100mm	3.94"	125mm	4.92"	100mm	3.94"	150mm	5.91"	200mm	7.87"
D	-		30mm	1.18"	40mm	1.57"	40mm	1.57"	60mm	2.36"	60mm	2.36"	80mm	3.15"
E	12mm	0.47"	18mm	0.71"	20mm	0.79"	20mm	0.79"	22mm	0.87"	22mm	0.87"	22mm	0.87"
F	14mm	0.55"	16mm	0.63"	20mm	0.79"	20mm	0.79"	23mm	0.91"	23mm	0.91"	23mm	0.91"
G	9mm	0.35"	12mm	0.47"	14mm	0.55"	14mm	0.55"	15mm	0.59"	15mm	0.59"	15mm	0.59"
H	23mm	0.91"	28mm	1.10"	35mm	1.38"	35mm	1.38"	38mm	1.50"	38mm	1.50"	38mm	1.50"

Machining Status

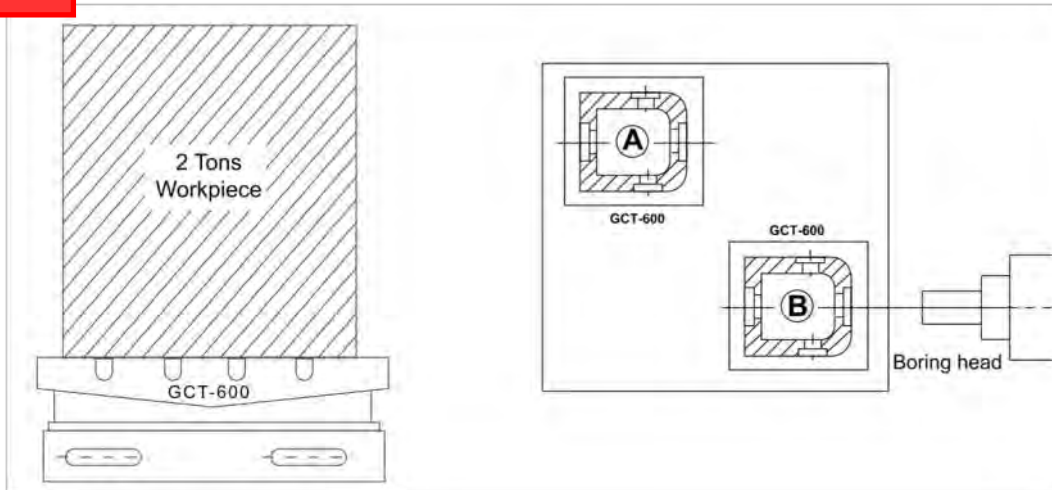

Allowed Loading Chart

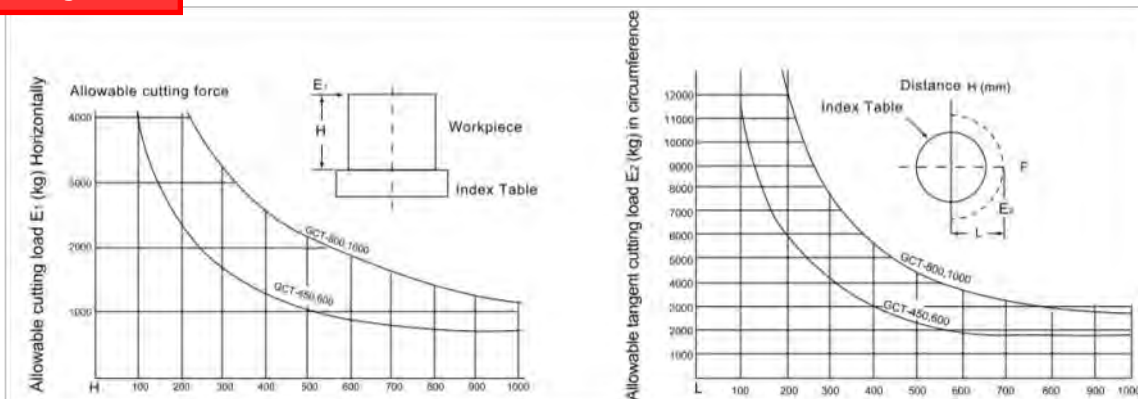

Horizontal Machining Center Table with Pallets APCR/APCI-400, 500, 630, 800, 1000

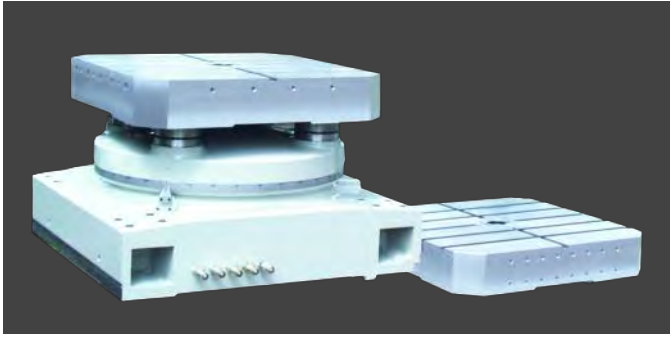

- High accuracy and tested modular system for table (receiver) & single/multi pallets design.
- Suitable for new horizontal machining centers as well as for existing customer's design horizontal table/pallets manufacturing.
- Tall units table (receiver) & single/multi pallets are manufactured from high quality materials and workmanship.
- Can be furnished to DIN, ISO, or customer's design. All pallets are exchangeable for every index tables or AX tables (receivers) pallets changing type can be swing or forward/backward designed.
- High accuracy 4 pieces cones/caps.
- Hydraulic 4 pieces pull studs or clamping plate.
- Can be designed to match customer's drawings saddle.
- 1 degree or 0.001 degree increment options available.
+/- 2 sec. or +/- 3 sec. (APR series: encoder is required)

Model	APCR/APCI 400		APCR/APCI 500		APCR/APCI 630		APCR/APCI 800		APCR/APCI 1000	
Pallet dimensions	400mm	15.75"	500mm	19.69"	630mm	24.8"	800mm	31.5"	1000mm	39.37"
T-slots size	14mm	0.55"	14mm	0.55"	18mm	0.71"	22mm	0.87"	22mm	0.87"
Rounded corners	500mm	19.69"	628mm	24.72"	800mm	31.5"	1040mm	40.94"	1570mm	61.81"
Total height	370mm	14.57"	550mm	21.65"	505mm	19.88"	525mm	20.67"	550mm	21.65"
Clamping station weight	365kg	803lbs	600kg	1320lbs	750kg	1650lbs	900kg	1980lbs	1100kg	2420lbs
Pallet weight	75kg	165lbs	120kg	264lbs	170kg	374lbs	200kg	440lbs	300kg	660lbs
Max. loading (evenly distributed)	500kg	1100lbs	600kg	1320lbs	1200kg	2640lbs	2000kg	4400lbs	3000kg	6600lbs
Clamping force	3500kg	7700lbs	5500kg	12100lbs	6500kg	14300lbs	7000kg	15400lbs	8000kg	17600lbs
Machining Torque	1196Nm	882ft.-lbs	2254Nm	1662ft.-lbs	3234Nm	2385ft.-lbs	3430Nm	2529ft.-lbs	4410Nm	3252ft.-lbs
Parallelism	0.015mm	0.00059"	0.015mm	0.00059"	0.025mm	0.00098"	0.03mm	0.0012"	0.03mm	0.0012"
Repeatability	0.01mm	0.00039"	0.01mm	0.00039"	0.01mm	0.00039"	0.01mm	0.00039"	0.01mm	0.00039"

APCI-500

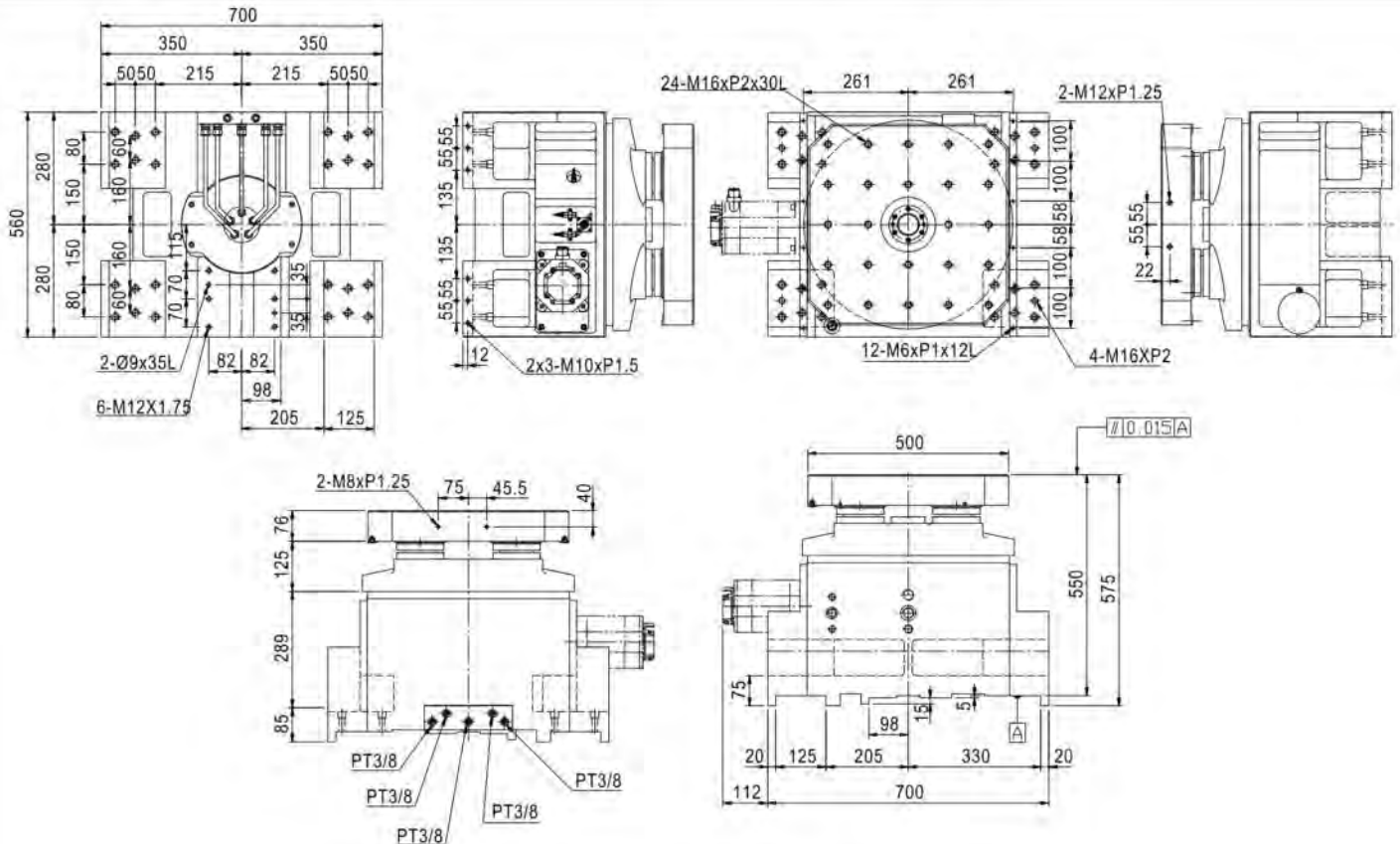

Horizontal Machining Center Table with Pallets APCR/APCI-400, 500, 630, 800, 1000

APCR-630

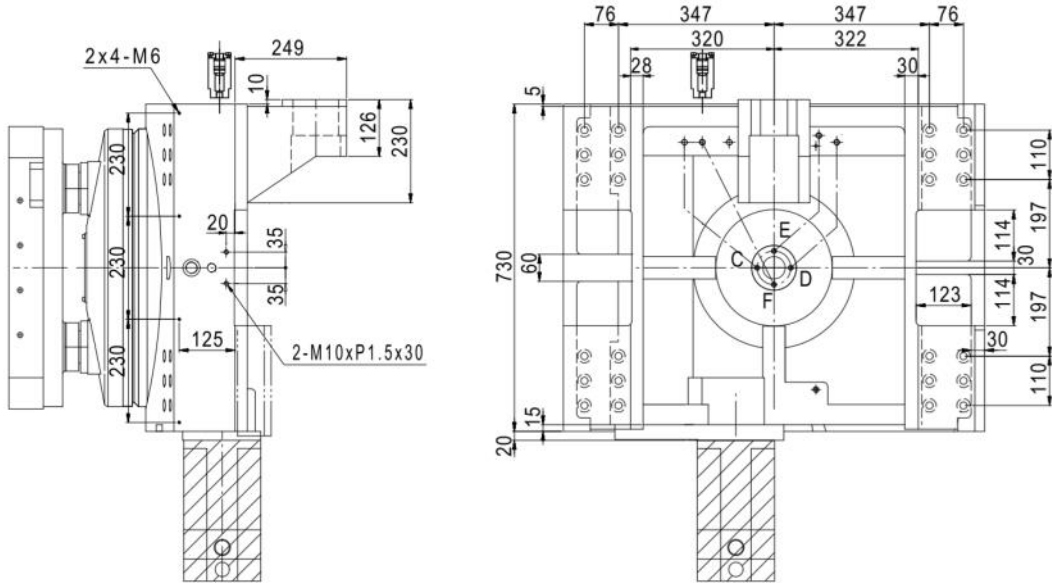

APCR-800

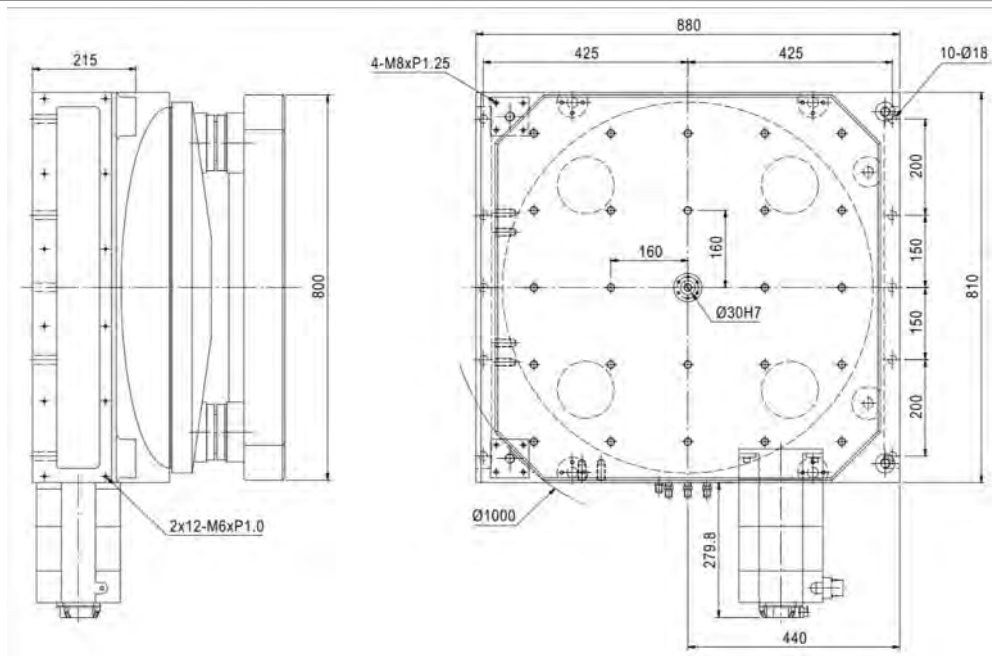

APCR-1000

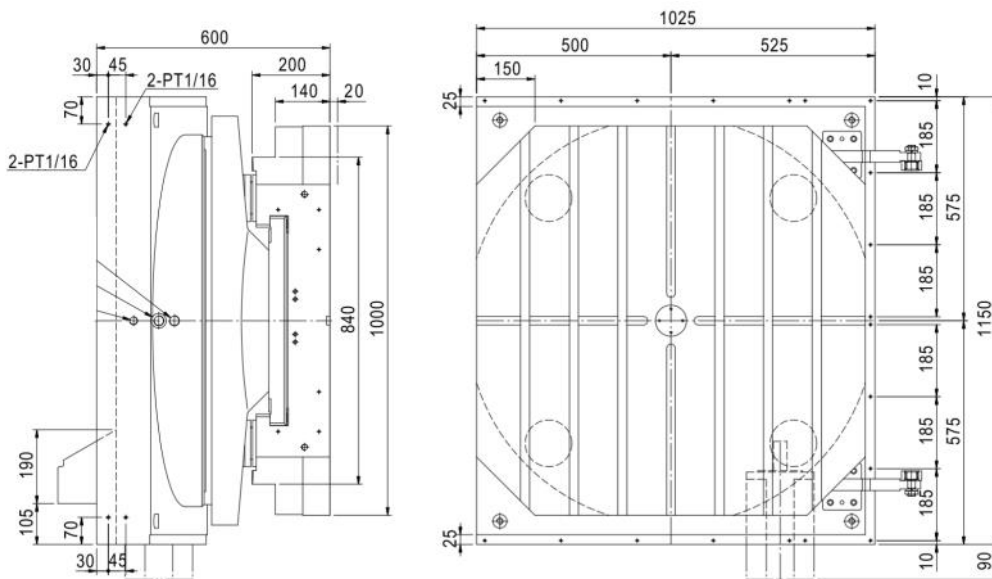

TS-A

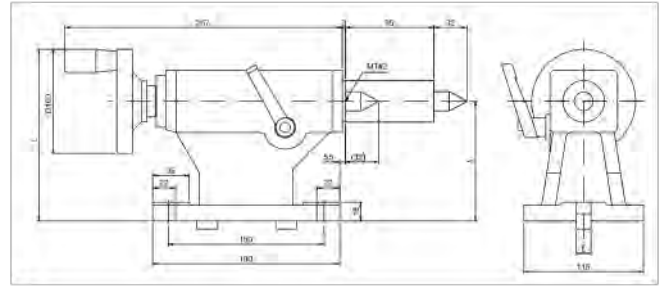
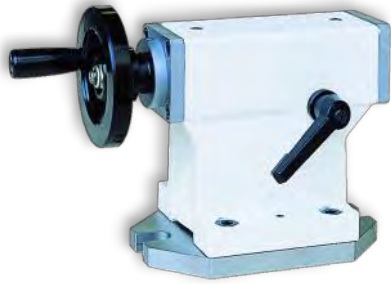

Model	A		B		C		Center Taper	Suitable Rotary Table
TS-A115	115mm	4.53"	14mm	0.55"	165mm	6.50"	MT#2	AX-120R
TS-A135	135mm	5.31"	18mm	0.71"	185mm	7.28"	MT#2	AX-170R, AX-170RB
TS-A160	160mm	6.30"	18mm	0.71"	210mm	8.27"	MT#2	AX-200R, AX-200RB

TS-B

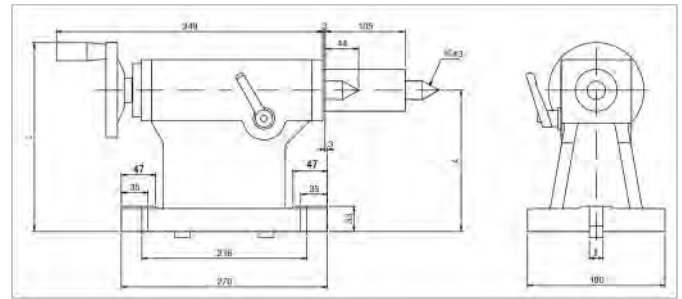

Model	A		B		C		Center Taper	Suitable Rotary Table
TS-B185	185mm	7.28"	18mm	0.71"	250mm	9.84"	MT#3	AX-250R, NCF-250, AX-250RB
TS-B190	190mm	7.48"	18mm	0.71"	255mm	10.04"	MT#3	CNCMT-200
TS-B210	210mm	8.27"	18mm	0.71"	275mm	10.83"	MT#3	AX-320R, NCF-320, CNCMT-250
TS-B250	250mm	9.84"	18mm	0.71"	315mm	12.4"	MT#3	AX-400R, NCF-400
TS-B255	255mm	10.04"	18mm	0.71"	320mm	12.6"	MT#3	CNCT-320
TS-B270	270mm	10.63"	18mm	0.71"	345mm	13.58"	MT#3	CNCMT-320

TS-C

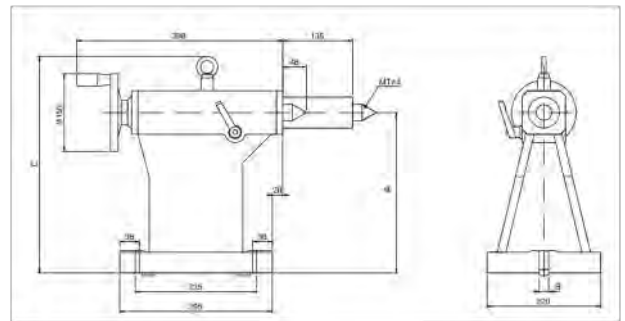

Model	A		B		C		Center Taper	Suitable Rotary Table
TS-C310	310mm	12.2"	18mm	0.71"	420mm	16.54"	MT#4	AX-500R
TS-C400	400mm	15.75"	18mm	0.71"	510mm	20.08"	MT#4	AX-630R
TS-C480	480mm	18.90"	22mm	0.87"	590mm	23.23"	MT#4	AX-800R

TS-A (P)

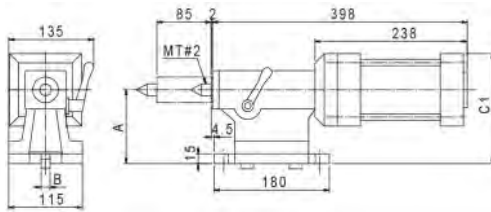

TS-A (H)

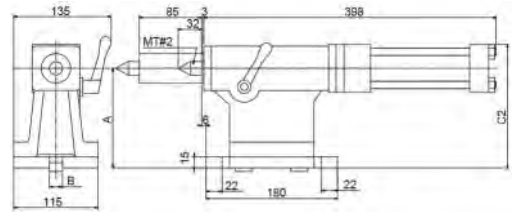

Model	A		B		C1(P)		C2(H)		Center Taper	Suitable Rotary Table
TS-A115(P/H)	115mm	4.53"	14mm	0.55"	172mm	6.77"	148mm	5.83"	MT#2	AX-120R
TS-A135(P/H)	135mm	5.31"	18mm	0.71"	192mm	7.56"	168mm	6.61"	MT#2	AX-170R, AX-170RB
TS-A160(P/H)	160mm	6.30"	18mm	0.71"	217mm	8.54"	193mm	7.60"	MT#2	AX-200R, AX-200RB

TS-B(P)

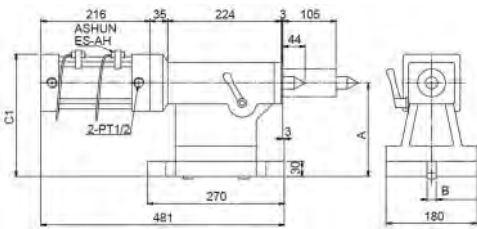

TS-B(H)

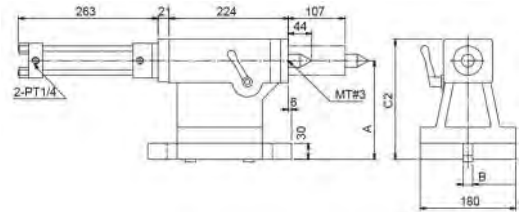

Model	A		B		C1(P)		C2(H)		Center Taper	Suitable Rotary Table
TS-B185(P/H)	185mm	7.28"	18mm	0.71"	242mm	9.53"	225mm	8.86"	MT#3	AX-250R, NCF-250, AX-250RB
TS-B190(P/H)	190mm	7.48"	18mm	0.71"	247mm	9.72"	230mm	9.06"	MT#3	CNCMT-200
TS-B210(P/H)	210mm	8.27"	18mm	0.71"	267mm	10.51"	250mm	9.84"	MT#3	AX-320R, NCF-320, CNCMT-250
TS-B250(P/H)	250mm	9.84"	18mm	0.71"	307mm	12.09"	290mm	11.42"	MT#3	AX-400R, NCF-400
TS-B255(P/H)	255mm	10.04"	18mm	0.71"	312mm	12.28"	295mm	11.61"	MT#3	CNCT-320
TS-B270(P/H)	270mm	10.63"	18mm	0.71"	327mm	12.87"	310mm	12.2"	MT#3	CNCMT-320

TS-C(P)

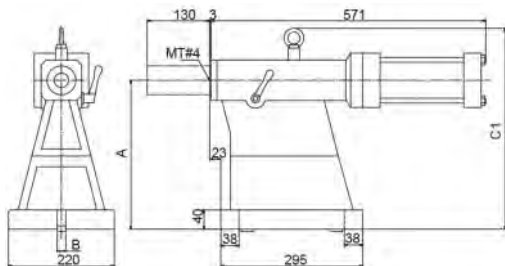

TS-C(H)

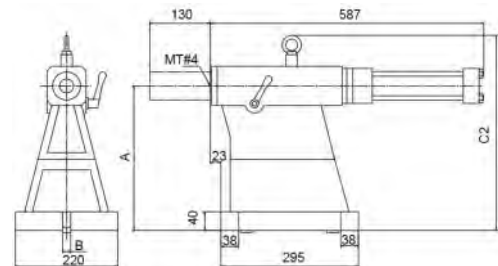

Model	A		B		C1(P)		C2(H)		Center Taper	Suitable Rotary Table
TS-C310(P/H)	310mm	12.2"	18mm	0.71"	420mm	16.54"	420mm	16.54"	MT#4	AX-500R
TS-C400(P/H)	400mm	15.75"	18mm	0.71"	510mm	20.08"	510mm	20.08"	MT#4	AX-630R
TS-C480(P/H)	480mm	18.9"	22mm	0.87"	590mm	23.23"	590mm	23.23"	MT#4	AX-800R

TSA-251S

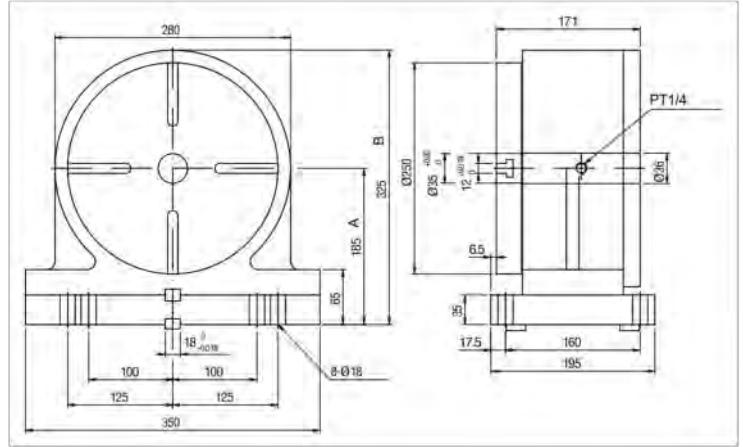

TSA-320S

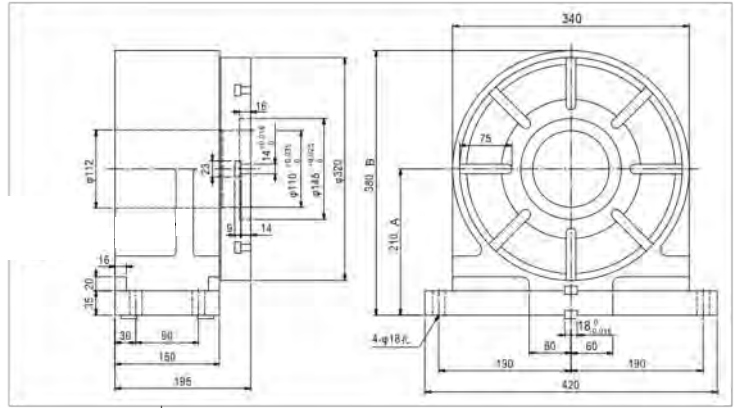

Model	TSA-120S		TSA-200S		TSA-251S		TSA-320S	
Table Diameter	120mm	4.72"	200mm	7.87"	250mm	9.84"	320mm	12.6"
(A) Center Height	115mm	4.53"	160mm	6.30"	185mm	7.28"	210mm	8.27"
(B) Overall Height	196mm	7.72"	265mm	10.43"	325mm	12.8"	380mm	14.96"
Center Hole	30mm	1.18"	35mm	1.38"	35mm	1.38"	110mm	4.33"
Width of Guide Block	14mm H7	0.55" H7	18mm h7	0.71" h7	18mm h7	0.71" h7	18mm h7	0.71" h7
Width of T-slot	10mm H7	0.39" H7	12mm H7	0.47" H7	12mm H7	0.47" H7	14mm H7	0.55" H7
Pneu.clamp force (at 72psi)	147.1Nm	108.5ft-lbs	245.2Nm	180.8ft-lbs	637.4Nm	470.1ft-lbs	784.5Nm	578.6ft-lbs
Net Weight without motors	20kg	44lbs	45kg	99lbs	82kg	180lbs	138kg	304lbs
Suitable Rotary Table	AX-120R		AX-170R		AX-250R		AX-320R	
			AX-200R		AX-320R		AX-400R	
			-		AX-400R		AX-500R	

* All specifications are subject to change without prior notice.



Pioneer Chuck / Hydraulic Cylinder / Tailstock







Suitable Rotary Table		AX-120R	AX-170R	AX-200R	AX-250R	AX-320R	AX-400R	AX-500R	AX-630R	AX-800R
Manual scroll chuck	Model No.	585-004	585-106	585-106	585-108	585-112	585-112	585-112	585-112	585-112
	Size	4"	6"	7"	8"	12"	12"	12"	12"	12"
Hydraulic chuck (Non thru hole)	Model No.	595-855	595-855	595-855	595-856	595-858	595-860	595-860	-	-
	Size	6"	6"	6"	8"	10"	12"	12"	15"	15"
Tailstock Type	Manual	TS-A115	TS-A135	TS-A160	TS-B185	TS-B210	TS-B250	TS-C310	TS-C400	TS-C480
	Pneumatic	TS-A115P	TS-A135P	TS-A160P	TS-B185P	TS-B210P	TS-B250P	TS-C310P	TS-C400P	TS-C480P
	Hydraulic	TS-A115H	TS-A135H	TS-A160H	TS-B185H	TS-B210H	TS-B250H	TS-C310H	TS-C400H	TS-C480H
	Strong (P/H)	TSA-120S	TSA-200S	TSA-200S	TSA-251S	TSA-251S TSA-320S	TSA-251S TSA-320S	TSA-320S	TSA-320S	TSA-320S





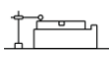

Yukiwa Chuck / Hydraulic Cylinder / Tailstock

Suitable Rotary Table		JNC140	JNC170	JNC200	JNC250	YNCP170	YNCP200	YNCP250	BNC320	TNT100	TNT170
Manual scroll chuck	Model No.	585-004 & 585-005	585-105 & 585-106	585-106	585-108	585-105 & 585-106	585-106	585-108	585-112	585-004 & 585-005	585-106
	Size	4" & 5"	5" & 6"	6"	8"	5" & 6"	6"	8"	12"	4" & 5"	6"
Hydraulic chuck (Non thru hole)	Model No.	N/A	595-855	595-855	595-856	595-855	595-855	595-856	595-860	N/A	595-855
	Size	4" & 5"	5" & 6"	6"	8"	5" & 6"	6"	8"	12"	4" & 5"	6"
Rotary hydraulic cylinder	Model No.	SJ4L	SJ6L/SJ6H	SJ6L/SJ6H	SJ6L/SJ6H	SJ6L/H	SJ6L/H	SJ6L/H	N/A	N/A	N/A
Tailstock Type	Manual	TSA110S	TSA135S/ TSB135S	TSB160S	TSB200S	TSA135S/ TSB135S	TSB160S	TSB200S	TSB230	N/A	N/A
	Pneumatic	TPA110	TPA135	TPA160	TPA200	TPA135	TPA160	TPA200	N/A	N/A	N/A
	Pneumatic w/ confirmation switch	TPB110	TPB135	TPB160	TPB200	TPB135	TPB160	TPB200	N/A	N/A	N/A
	Side Spindle	SS110	SS135	SS160	SS200	SS135	SS160	SS200	N/A	N/A	N/A
	Side Table	N/A	ST135	ST160	ST200	ST135	ST160	ST200	ST230	N/A	N/A

Accuracy Standards (Unit: inch)							
Model\Item	Table top flatness	Parallelism of table top and frame bottom	Runout of table spindle center	Perpendicularity of table top to frame bottom	Table top runout	Perpendicularity of table top to frame bottom guide block	Parallelism of center line between headstock & tailstock to frame bottom guide block
AX-120R	0.0003	0.0003	0.0005	0.0004	0.0003	0.0007	0.0007
AX-170R	0.0003	0.0003	0.0003	0.0007	0.0005	0.0007	0.0007
AX-200R	0.0003	0.0003	0.0003	0.0007	0.0005	0.0007	0.0007
AX-250R	0.0003	0.0003	0.0003	0.0007	0.0005	0.0007	0.0007
AX-320R	0.0003	0.0003	0.0003	0.0007	0.0005	0.0007	0.0007
AX-400R	0.0005	0.0005	0.0003	0.0007	0.0005	0.0007	0.0007
AX-500R	0.0005	0.0005	0.0003	0.0007	0.0005	0.0007	0.0007
AX-630R	0.0009	0.0009	0.0003	0.0009	0.0007	0.0007	0.0007
AX-800R	0.0009	0.0009	0.0003	0.0009	0.0007	0.0007	0.0007
AX-120RB	0.0003	0.0003	0.0003	0.0007	0.0005	0.0007	0.0007
AX-170RB	0.0003	0.0003	0.0003	0.0007	0.0005	0.0007	0.0007
AX-200RB	0.0003	0.0003	0.0003	0.0007	0.0005	0.0007	0.0007
AX-250RB	0.0003	0.0003	0.0003	0.0007	0.0005	0.0007	0.0007
AX-200R-3W	0.0003	0.0007	0.0003	0.0004	0.0005	0.0007	0.0007

Accuracy Standards (Unit: inch)								
Model/Item	Table top flatness	Parallelism of table top and frame bottom	Runout of table spindle center	Table top runout	Parallelism of tilting axis center line and frame bottom	Parallelism of table top to frame bottom guide	An encoder measuring instrument should be used for indexing accuracy measurements (Rotating)	An encoder measuring instrument should be used for indexing accuracy measurements (Tilting)
AX5-100	0.0003	0.0007	0.0003	0.0005	0.0007	0.0007	30"	60"
AX5-200	0.0003	0.0007	0.0003	0.0005	0.0007	0.0007	25"	50"
AX5-250	0.0003	0.0007	0.0003	0.0005	0.0007	0.0007	15"	50"
AX5-320T	0.0003	0.0007	0.0003	0.0005	0.0007	0.0007	15"	30"
AX5-450	0.0003	0.0007	0.0003	0.0005	0.0007	0.0007	15"	30"
AX5-630	0.0003	0.0007	0.0003	0.0005	0.0007	0.0007	15"	30"
AX5-800	0.0003	0.0007	0.0003	0.0005	0.0007	0.0007	15"	30"
AX4MT-201	0.0003	0.0007	0.0003	0.0005	0.0007	0.0007	25"	
AX4MT-250	0.0003	0.0007	0.0003	0.0005	0.0007	0.0007	25"	
AX4MT-320	0.0003	0.0007	0.0003	0.0005	0.0007	0.0007	15"	
AX4MT-400	0.0007	0.0007	0.0003	0.0005	0.0007	0.0007	15"	
AX4MT-500	0.0007	0.0007	0.0003	0.0005	0.0007	0.0007	15"	
AX4MT-630	0.0007	0.0007	0.0003	0.0005	0.0007	0.0007	15"	

Accuracy Standards (Unit: inch)							
Model\Item	Table top flatness	Parallelism of table top and frame bottom	Runout of table spindle center	Perpendicularity of table top to frame bottom	Table top runout	Perpendicularity of table top to frame bottom guide block	Parallelism of center line between headstock & tailstock to frame bottom guide block
							
AX4H-250R	0.0003	0.0003	0.0005	0.0005	0.0003	0.0007	0.0007
AX4H-320R	0.0003	0.0003	0.0003	0.0005	0.0003	0.0007	0.0007
AX4H-400R	0.0005	0.0005	0.0003	0.0007	0.0005	0.0007	0.0007
AX4H-500R	0.0005	0.0005	0.0003	0.0007	0.0005	0.0007	0.0007

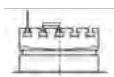
Accuracy Standards (Unit: inch)									
Model\Item	Concentricity of center spigot	Flatness of table surface	Table oscillation	Parallelism between bottom and top surfaces	T-slot right angle	Right angle of table side	Concentricity and T-slot side	Test By NIKON "Auto collimator"	
								Divide into 4 equal parts	Divide into 72 equal parts
GCT-301	0.0003	0.0003	0.0003	0.0003	0.0005	0.0005	0.0005	+/-2"	+/-3"
GCT-450	0.0003	0.0005	0.0003	0.0005	0.0005	0.0005	0.0005	+/-2"	+/-3"
GCT-600	0.0003	0.0007	0.0005	0.0007	0.0007	0.0007	0.0007	+/-2"	+/-3"
GCT-700	0.0003	0.0007	0.0005	0.0007	0.0007	0.0007	0.0007	+/-2"	+/-3"
GCT-800	0.0003	0.0007	0.0005	0.0007	0.0007	0.0007	0.0007	+/-2"	+/-3"
GCT-1000	0.0003	0.0011	0.0007	0.0011	0.0011	0.0011	0.0007	+/-2"	+/-3"
GCT-1200	0.0003	0.0011	0.0007	0.0011	0.0011	0.0011	0.0007	+/-2"	+/-3"



Premium Work Holding Systems

Rotary table inquiry form

Dealer: _____	End User: _____
Company: _____	Company: _____
Contact: _____	Contact: _____
Address: _____	Address: _____
City: _____ State: _____ Zip Code: _____	City: _____ State: _____ Zip Code: _____
Email: _____	Email: _____
Phone: _____ Cell: _____	Phone: _____ Cell: _____

Machine Tool Info

Manufacturer: _____ Model: _____ Year: _____

Control Make: _____ Model: _____

Machine condition: New / Existing or used

Please describe type of the machine. For example, 3 axis vertical machine, horizontal machine with C-axis, vertical with rotary pallet etc.

Table size: X _____ Y _____ Axis travel: X _____ Y _____ Z _____

Workpiece and Application Info

Workpiece dimension: _____

Material: _____ Weight: _____

Application is mainly: Drill / Mill Contour milling: Yes / No

Please describe about your application:

Rotary table info

Size of face plate: _____ Number of axis: 4th / 4th & 5th

Motor orientation (4th axis models only) : Right(standard) / Left / Top / Back

Type of connection: Integrated 4th axis / Integrated 4th & 5th axis / Indexer with control box/ other

Special request

Rotary Table Interface and Installation RFQ Quick Check List

1. Information of the machine
Manufacturer: _____ Model: _____ Year: _____
Control Make: _____ Model: _____
2. Can the customer or dealer send the data sheet of the machine that they can send? Data sheet is usually provided with the machine manual. Yes / No
3. Can the customer or dealer send the electrical manual and electric diagram of the machine? Yes/ No
4. Are these options on your control?
 - a. 4th axis select switch on the control panel Yes/ No
 - b. 5th axis select switch on the control panel Yes/No
 - c. 4th select switch axis on the MPG jog Yes/No
 - d. 5th axis select switch on the control panel Yes/No
 - e. None of above
5. Does the machine have bulkhead mount area for additional axis?
6. Does the machine have 4th and 5th axis software (PLC ladder) preinstalled?
7. Can the customer send pictures of the following?
 - a. Control panel and MPG jog
 - b. Machine table
 - c. Additional axis bulk head mount area
 - d. Inside the back cabinet to see amplifier terminals, I/O terminals etc.

Following control and machine builders are most popular machines we can offer installation. If your machine control or machine builder is not on the list, please contact us.

Control make

- Fanuc OiM series / 16i / 18i / 21i
- Some models of Yaskawa
- Some models of Mitsubishi

Machine builders

- Mori Seiki
- Kitamura
- Fanuc RoboDrill
- OKK
- Enshu
- Toyoda
- Bridgeport
- Doosan
- Daewoo
- Hyundai-Wia
- YCM
- Johnford



Wire EDM

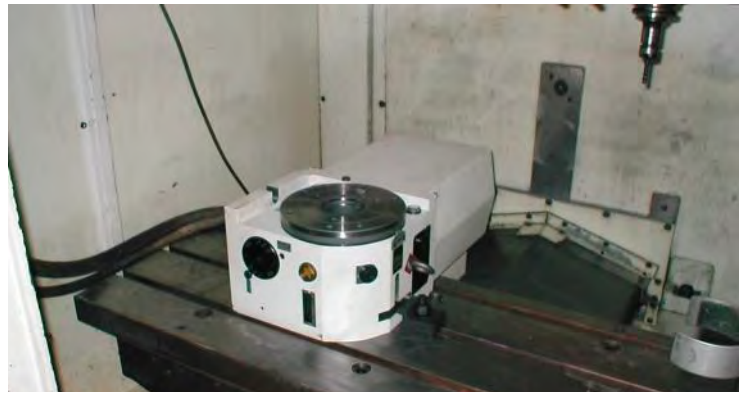

Vertical Machining Center



Vertical Machining Center



Vertical Machining Center

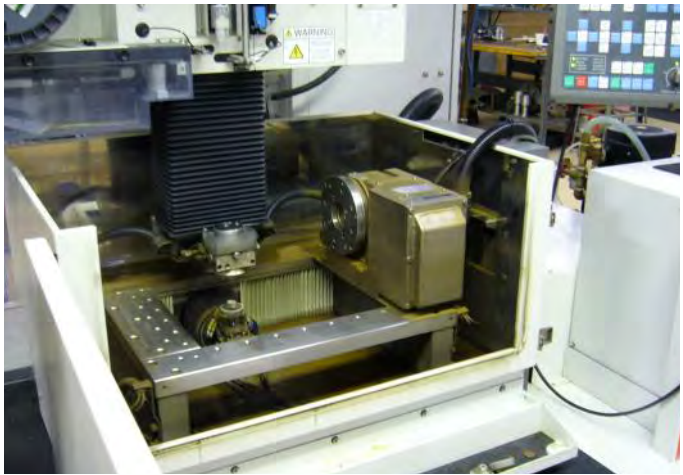

Wire EDM



Vertical Machining Center

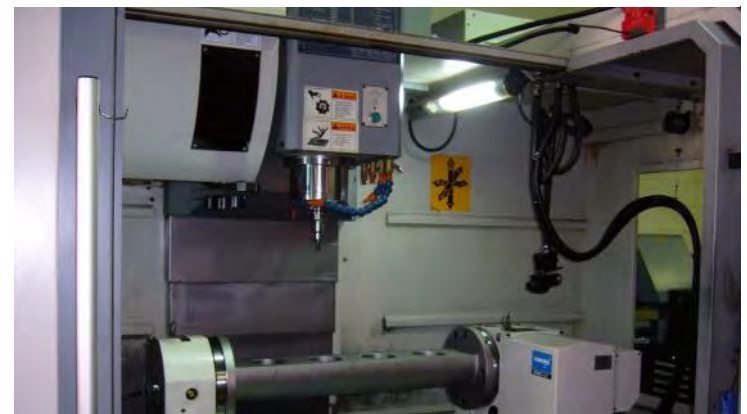

Vertical Machining Center



Vertical / Horizontal Machining Center

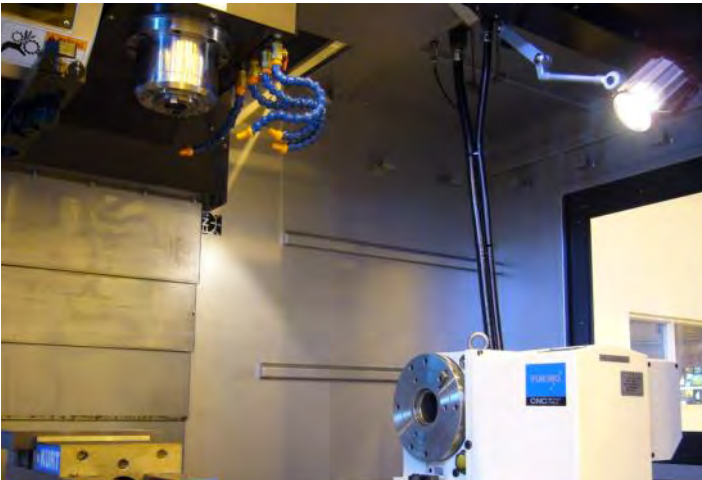

Vertical Machining Center

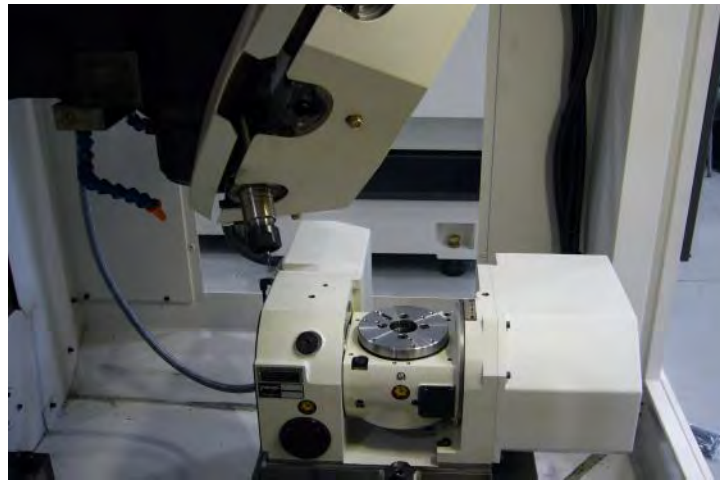

Vertical Machining Center



Vertical Machining Center

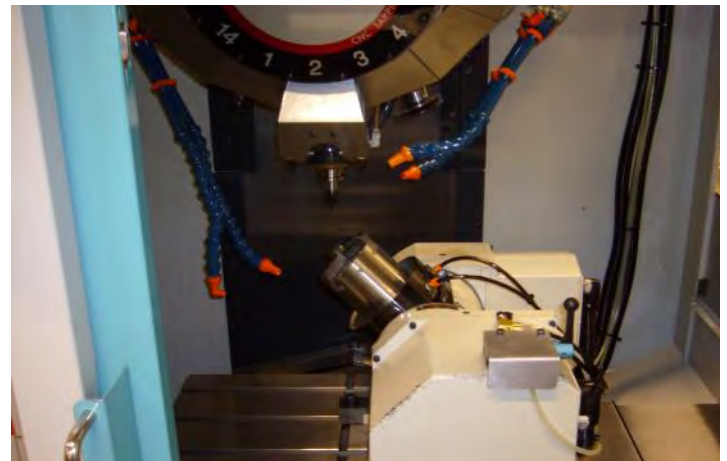

Vertical Machining Center

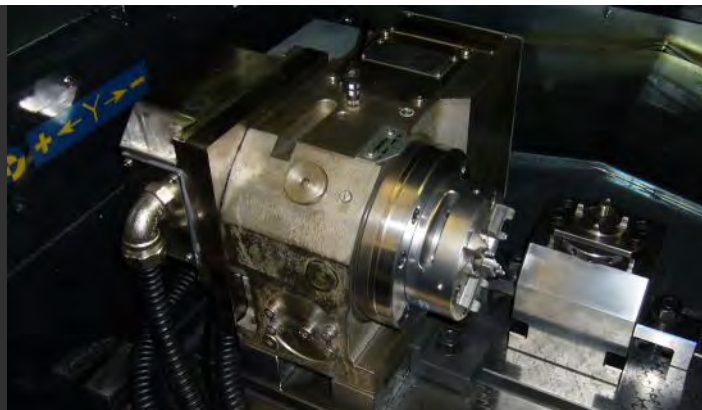

Rotary Scale Option for Graphite Application



Vertical Machining Center

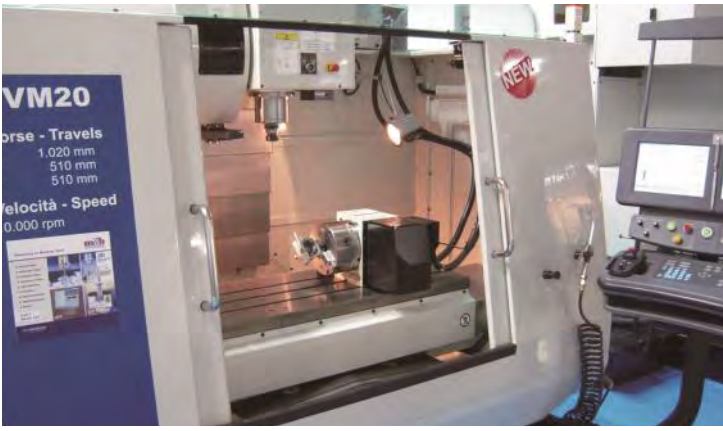

Vertical Machining Center



Vertical Machining Center

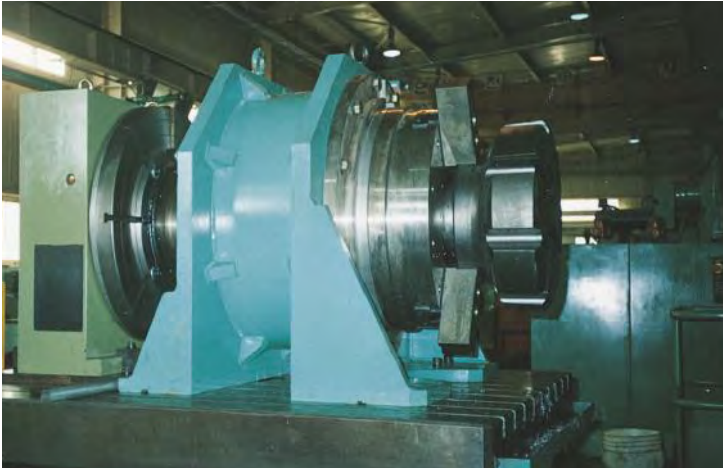

Horizontal Machining Center or Conventional Machining



Vertical Machining Center

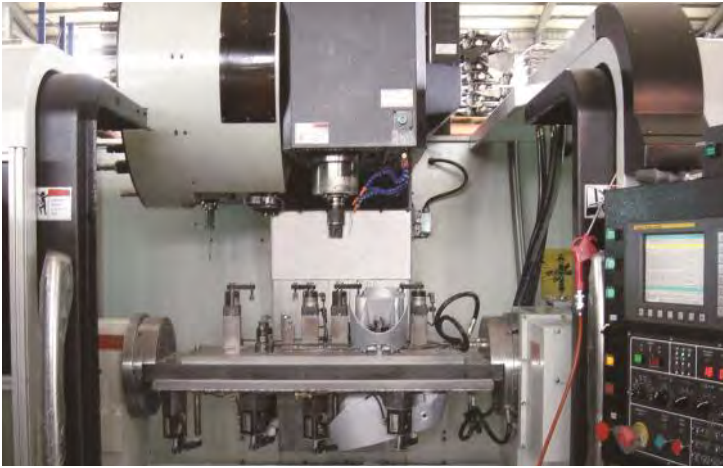

Vertical Machining Center

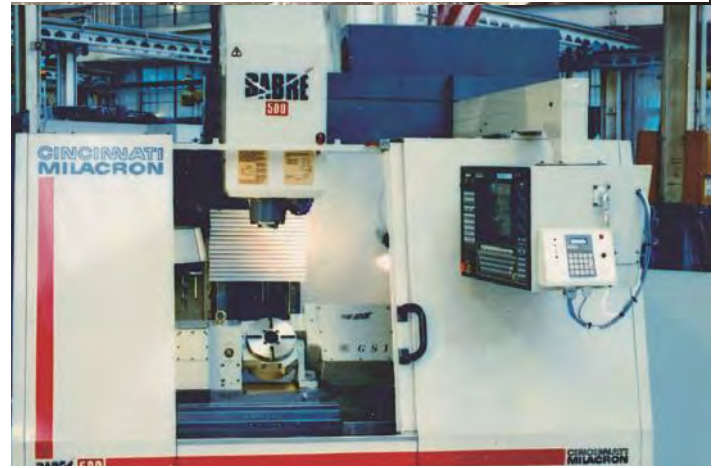

Vertical Machining Center



Vertical / Horizontal Machining Center



Vertical Machining Center



Horizontal Machining Center



Premium Work Holding Systems



Vertical Machining Center



AX-1500RV + Horizontal Machining Center

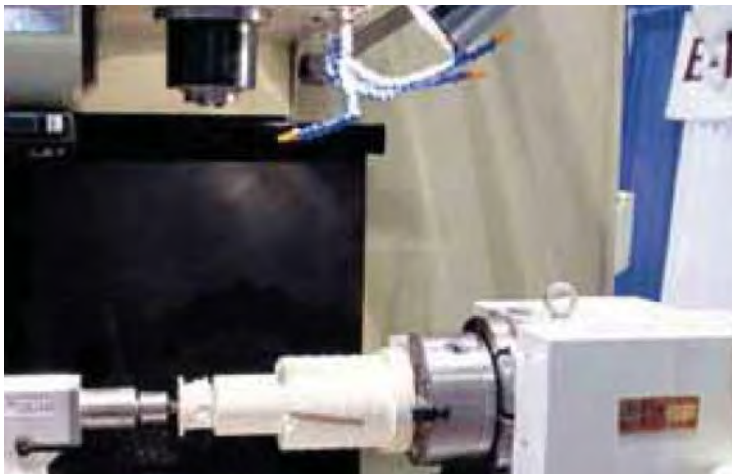

Vertical / Horizontal Machining Center

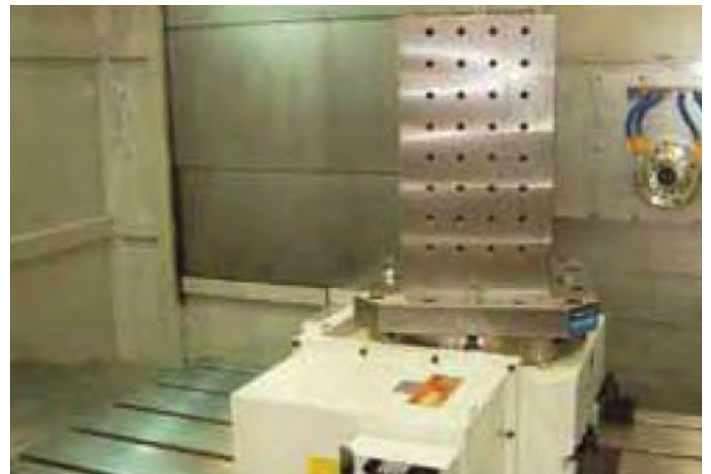

Horizontal Machining Center



Vertical / Horizontal Machining Center



Large Size Machining Center



Pioneer North America

641 Fargo Avenue
Elk Grove Village, IL 60007
USA

T: 800-991-4225 | E: customerservice@ahbinc.com