

RAIL SYSTEM

Most machine shops lose a lot of time in setting up their machines. WOW Workholding offers an efficient and predictable setup solution. Our customers are better prepared for their machining processes and as a result have less stress in their manufacturing.

5 ADVANTAGES

1. Easy to Install
2. Excellent Repeat-ability
3. Never Indicate a Vice Again
4. Hold Irregular Parts
5. High Torque

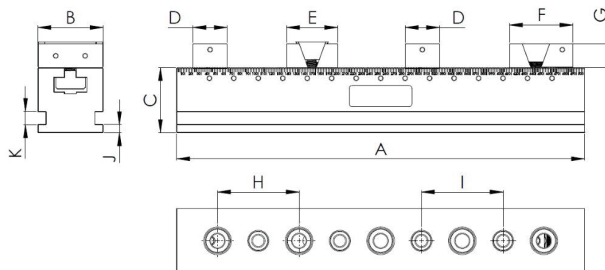
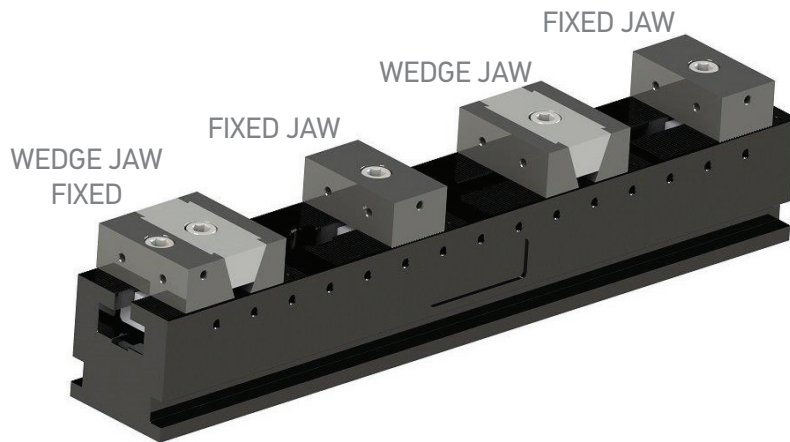

PART #	A (MM)	B (MM)	C (MM)	D (MM)	E (MM)	F (MM)	G (MM)	H (MM)	I (MM)	J (MM)	K (MM)
RAIL80X500X80	500	80	80	42	65	78	29	100	100	10	16.5
RAIL80X400X80	400	80	80	42	65	78	29	100	100	10	16.5
RAIL80X300X80	300	80	80	42	65	78	29	100	100	10	16.5

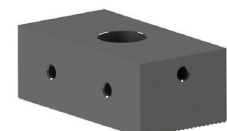

SMOOTH

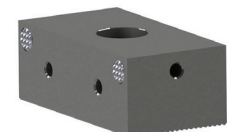

HARD METAL GRIPPERS

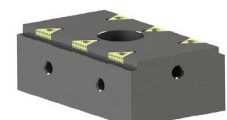

4MM STEP WITH CLAWS

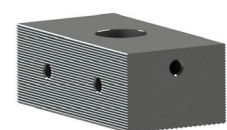

SERRATED

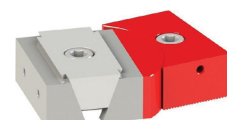

SWIVEL CONVERSION KIT



SCHEDULE AN APPOINTMENT
COMPLETE
METALWORKING
SOLUTIONS

(800) 991-4225

www.ahbinc.com

ISO Certified

customerservice@ahbinc.com



Proudly made in
NORTH AMERICA