



## **Adjusta-Point Radial Compensating Live Centers**

Over 40 percent of Riten's live centers are "specials," and a large number of current catalog models started out as a custom-engineered product for an individual customer.

The Adjusta-Point Live Center is yet another example. It is designed specifically for applications when a workpiece's center hole is not quite on center. The adjustable point locates in the center hole, centering the part by offsetting the deviation. The process is similar to indicating a part using a 4-jaw chuck.

The center is equipped with four external adjusting screws that can move the point up to .030" in any direction. Initially available in Morse tapers, with additional tapers by request. Specifications are shown on the reverse.

Bad center holes are an occasional nuisance, but with Riten's new Adjusta-Point Live Center, you have the tool to turn them from scrap into accurately machined parts.

**Riten<sup>®</sup>**

***Solutions, not excuses***

## Adjusta-Point Live Centers

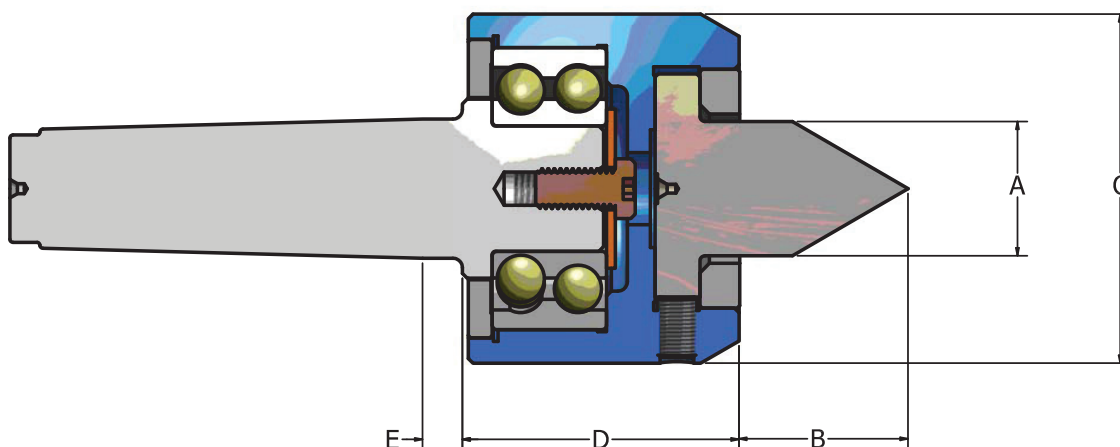

MORSE TAPER								
Model	MT	A	B	C	D	E	Max RPM	W. P. Weight
99993	3	1 <sup>11</sup> / <sub>16</sub>	2 <sup>1</sup> / <sub>8</sub>	4 <sup>3</sup> / <sub>8</sub>	3 <sup>15</sup> / <sub>32</sub>	1/2	3000	1500
99994	4	1 <sup>11</sup> / <sub>16</sub>	2 <sup>1</sup> / <sub>8</sub>	4 <sup>3</sup> / <sub>8</sub>	3 <sup>15</sup> / <sub>32</sub>	1/2	3000	3000
99995	5	1 <sup>11</sup> / <sub>16</sub>	2 <sup>1</sup> / <sub>8</sub>	4 <sup>3</sup> / <sub>8</sub>	3 <sup>15</sup> / <sub>32</sub>	1/2	3000	4500
99996	6	2 <sup>1</sup> / <sub>2</sub>	2 <sup>1</sup> / <sub>2</sub>	6 <sup>1</sup> / <sub>8</sub>	5 <sup>3</sup> / <sub>16</sub>	1/2	2500	7500
99997	7	2 <sup>1</sup> / <sub>2</sub>	2 <sup>1</sup> / <sub>2</sub>	6 <sup>1</sup> / <sub>8</sub>	5 <sup>3</sup> / <sub>16</sub>	1/2	2500	7500

Your local authorized Riten distributor:



COMPLETE METALWORKING SOLUTIONS  
 (800) 991-4225 [www.ahbinc.com](http://www.ahbinc.com)  
 ISO Certified [customerservice@ahbinc.com](mailto:customerservice@ahbinc.com)



*Solutions, not excuses*

**Riten Industries, Inc.**  
 1100 Lakeview Avenue, P.O. Box 340  
 Washington Court House, OH 43160 USA  
 800-991-4225