

ROYAL
PRODUCTS

AHB

COMPLETE
METALWORKING
SOLUTIONS

(800) 991-4225

www.ahbinc.com

ISO Certified

customerservice@ahbinc.com

MTC™

TOOLING & MACHINERY

MULTI-TASKING CHUCK

A REVOLUTIONARY 3-JAW CHUCK, COLLET CHUCK,
AND I.D. WORKHOLDING SYSTEM ALL-IN-ONE.

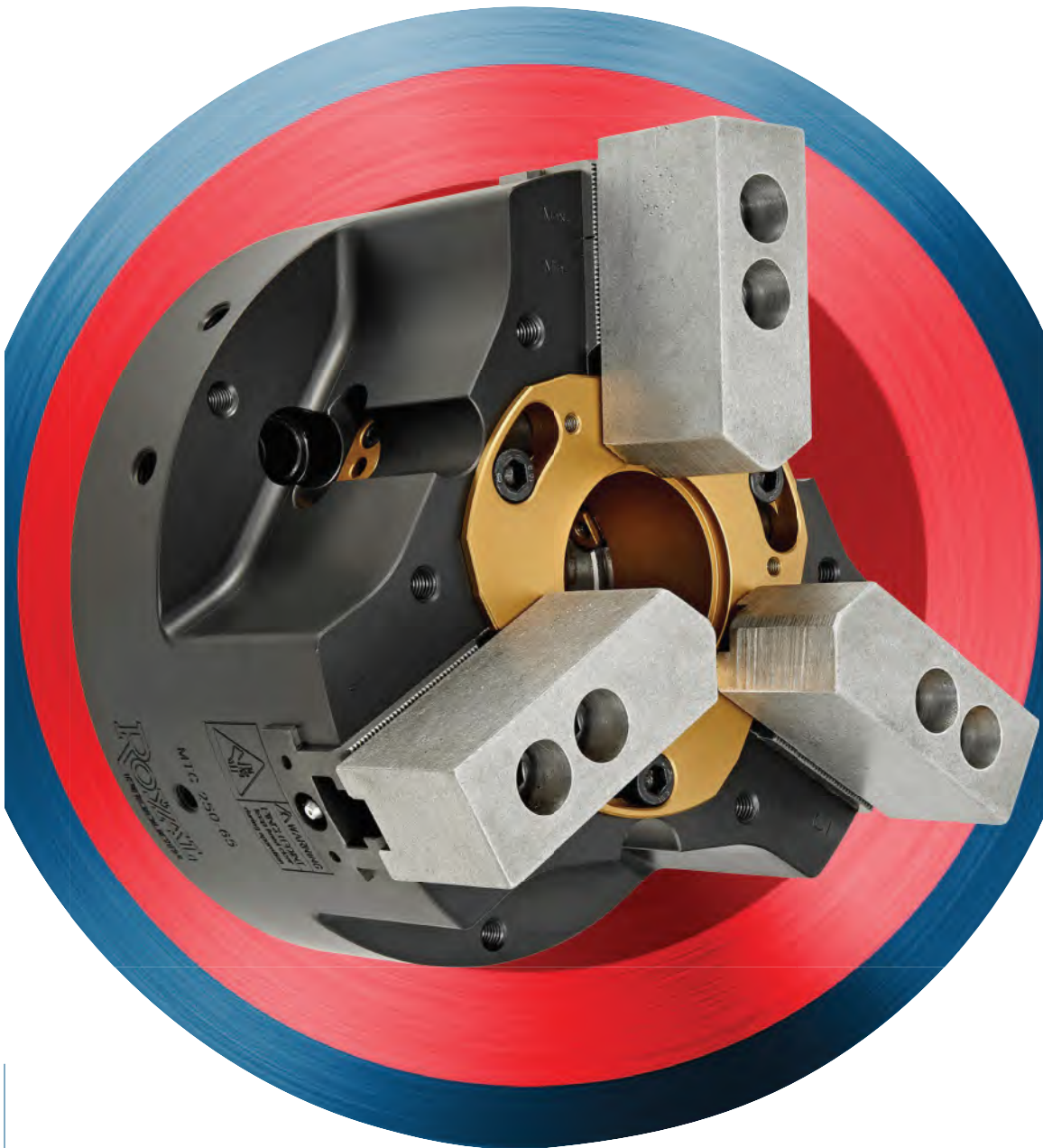

ROYAL
PRODUCTS
Optimize everything.



ROYAL MTC™ MULTI-TASKING CHUCK

A TRUE ALL-IN-ONE CNC LATHE CHUCK

THE ROYAL MTC™ IS A REVOLUTIONARY 3-JAW CHUCK, COLLET CHUCK, AND I.D. WORKHOLDING SYSTEM ALL-IN-ONE

No Need to Ever Change Your Chuck Again

Switching your lathe workholding as jobs demand can be a difficult process and eats up valuable production time. But no longer! With the Royal MTC™ it's a snap to change over between:

NEW

- ✓ 3-Jaw Chuck
- ✓ Quick-Grip™ CNC Collet Chuck
- ✓ I.D. Workholding System
- ✓ And much more...



Converting Between Jaw/Collet/I.D. Applications Takes Just Minutes and is Accomplished by **Simply Swapping the Quick-Change Center Hub**. The Chuck Body Never Needs to be Removed from the Lathe Spindle!

ROYAL MTC™ MULTI-TASKING CHUCK

A TRUE ALL-IN-ONE CNC LATHE CHUCK

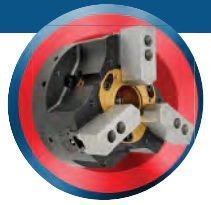

ROYAL MTC™ ADVANTAGES

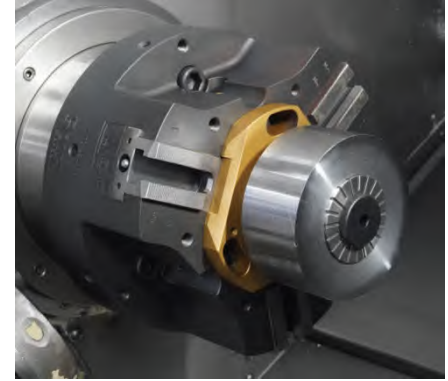
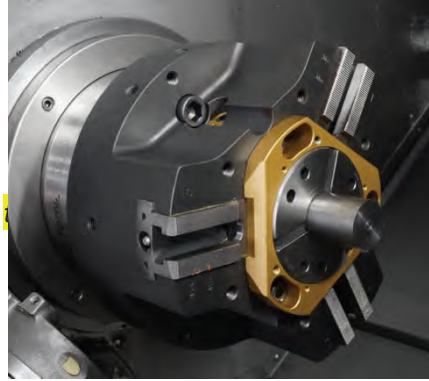
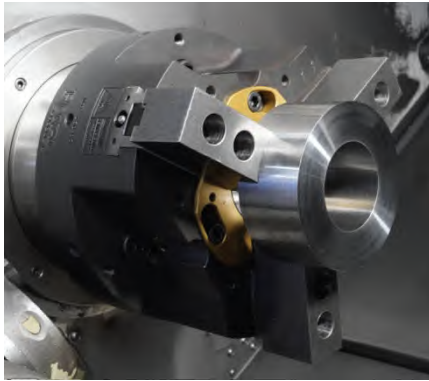

- The Royal MTC™ Multi-Tasking Chuck is the only chuck you'll ever need for your CNC lathes.
- This is a **true all-in-one workholding device** designed to handle large diameter parts, small diameter parts, and parts suited for I.D. gripping.
- The key to this revolutionary all-in-one design is the quick-change center hubs – there is no need to ever remove the chuck body from the lathe spindle.
- The center hubs are hardened, precision ground, and TiN coated for exceptional accuracy and wear resistance.
- Extreme rigidity is achieved through a **common-sense design** based upon a 3-jaw chuck with collet and I.D. capabilities - not a collet chuck with a heavy jaw-chuck hanging off the front end.
- Faster and much more cost-effective than changing out various chucks or using a "quick-change" adapter plate system that requires a crane and staging cart.
- High accuracy - jaw repeatability is 0.0002" - 0.0003", and collet hub taper is guaranteed to be within 0.0003" TIR.
- All chuck bodies are **relief milled to optimize tool clearance and reduce rotational mass**.
- Available in 8", 10", 12", and 15" sizes
- All Royal MTC™ Multi-Tasking Chucks include the following:
 - A 3-Jaw chuck featuring industry standard 60°x1.5mm base jaws to accept a wide array of top jaws.
 - A Quick-Grip™ center hub hardened and precision ground to accept Royal QG Collets.
 - A thru-hole center hub to accommodate long-parts when using as a jaw chuck.
 - A center cap to block chips from entering the drawtube when using the jaw chuck for slug work.
 - A removeable internal workstop for use with both jaws and collets.
 - A grease gun and tube of chuck grease.
 - A custom-machined drawtube connector for hassle-free installation.
- **Two-jaw chucks, face drivers, Morse Taper adapters, and alternative collet adapters (5C, 3J, etc.) are also available as special order.**
- The center hub for I.D. work is sold separately and is compatible with all Royal I.D. mandrels, stops, and sleeves (see full catalog for details).

**View the Royal MTC™ in action
at royalproducts.com**





ROYAL MTC™ MULTI-TASKING CHUCK

A TRUE ALL-IN-ONE CNC LATHE CHUCK

DIMENSIONS

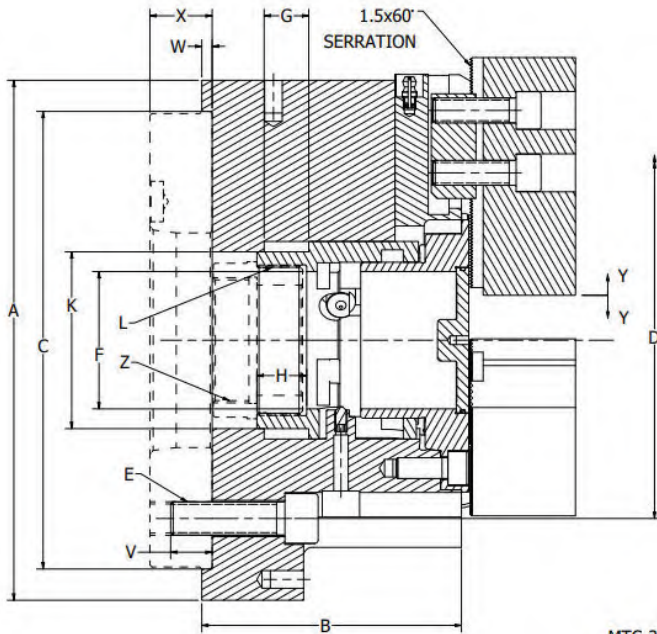

MTC-200/250/320/400 WITH JAWS

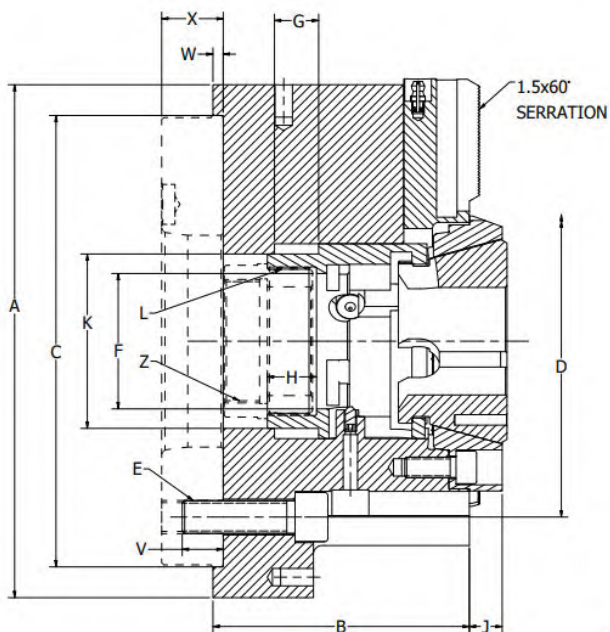
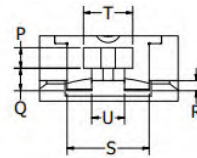
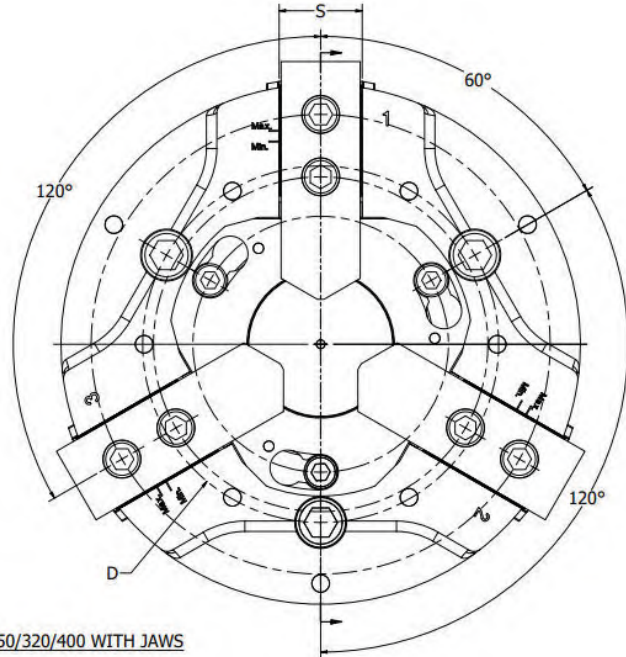

MTC-200/250/320/400 WITH COLLET

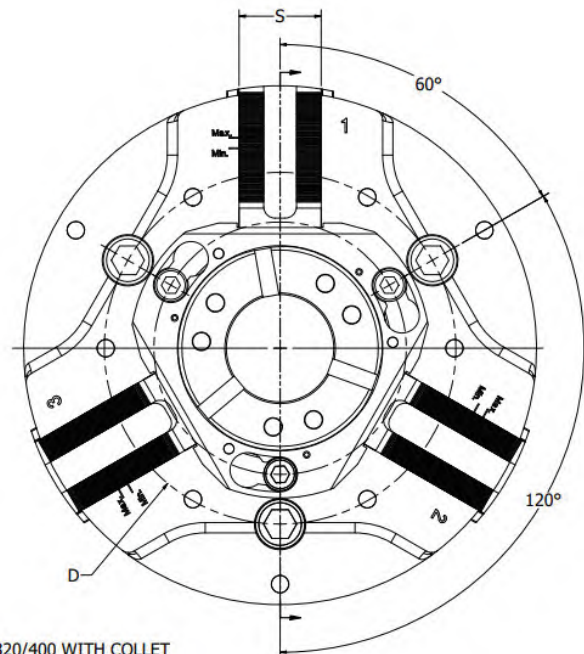

ROYAL MTC™ MULTI-TASKING CHUCK

A TRUE ALL-IN-ONE CNC LATHE CHUCK



DIMENSIONS

	MTC-200		MTC-250		MTC-320		MTC-400	
	Inch	Metric	Inch	Metric	Inch	Metric	Inch	Metric
A	7.87	200	9.84	250	12.60	320	15.75	400
B	4.33	110	4.92	125	5.91	150	6.89	175
C	6.69	170	8.66	220	11.02	280	13.78	350
D	5.25	133.4	6.75	171.4	9.25	235	12.21	310
E	M12		M16		M20		M20	
F	2.09	53	2.60	66	3.19	81	4.09	104
G (optimal)	0.79	20	0.95	24	1.10	28	1.34	34
G (minimum)	0.59	15	0.71	18	0.83	21	1.00	25.5
H	0.91	23	0.95	24	1.10	28	1.50	38
J	0.43	11	0.63	16	0.63	16	0.71	18
K	2.95	75	3.35	85	4.13	105	5.91	150
L	M64x1.5		M72x1.5		M92x2		M130x2	
P	0.39	10	0.39	10	0.47	12	0.59	15
Q	0.43	11	0.43	11	0.47	12	0.51	13
R	0.20	5	0.20	5	0.20	5	0.20	5
S	1.58	40	1.58	40	1.77	45	2.05	52
T	0.95	24	0.95	24	1.19	30.1	1.19	30.1
U	0.63	16	0.63	16	0.83	21	0.83	21
V	0.79	20	0.79	20	1.02	26	0.98	25
W	0.20	5	0.20	5	0.20	5	0.20	5
X	Varies		Varies		Varies		Varies	
Y	+/- 0.08	+/- 2.0	+/- 0.10	+/- 2.5	+/- 0.12	+/- 3.0	+/- 0.14	+/- 3.6
Z	Varies		Varies		Varies		Varies	

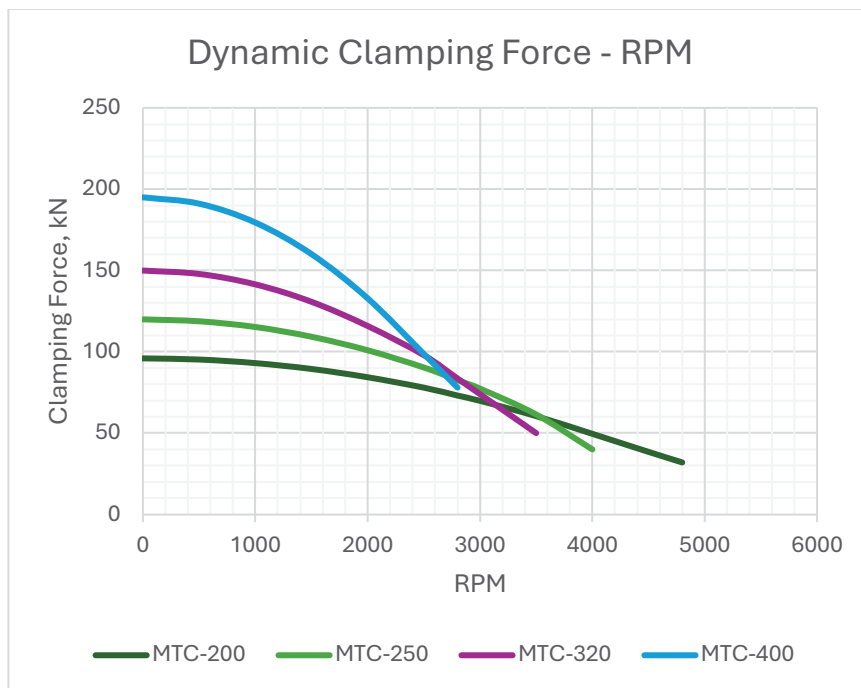

Warning: While the static clamping force of all three-jaw chucks is a function of the machine's hydraulic actuator (piston surface area, input pressure, etc.), it is essential to understand that the dynamic clamping force acting on a workpiece is affected by additional factors such as rpm and top jaw weight. This graph represents the maximum dynamic clamping force of all Royal MTC™ chuck models throughout the stated rpm range.

Be sure to understand the relationship between input pressure and drawtube axial force for your machine's specific hydraulic actuator and **ensure that all relevant parameters are sufficient to keep workpieces safely clamped.** If you have any questions or concerns regarding the safe use of this product, please contact a Royal Products applications engineer at 1-800-645-4174 before use.

MTC-200 Top Jaw Weight 4.9 lbs.
MTC-250 Top Jaw Weight 6.2 lbs.
MTC-320 Top Jaw Weight 7.9 lbs.
MTC-400 Top Jaw Weight 10.1 lbs.



ROYAL MTC™ MULTI-TASKING CHUCK

A TRUE ALL-IN-ONE CNC LATHE CHUCK

SPECIFICATIONS

Royal MTC™ with Chuck Jaws

	MTC-200		MTC-250		MTC-320		MTC-400	
	Inch	Metric	Inch	Metric	Inch	Metric	Inch	Metric
Optimal Drawtube Stroke	0.79	20	0.95	24	1.10	28	1.34	34
Clamping Range (Jaw/Diameter) at Optimal Drawtube Stroke	0.16/0.32	4/8	0.20/0.40	5/10	0.24/0.48	6/12	0.28/0.56	7.2/14.4
Minimum Drawtube Stroke	0.59	15	0.71	18	0.83	21	1.00	25.5
Clamping Range (Jaw/Diameter) at Minimum Drawtube Stroke	0.12/0.24	3/6	0.15/0.30	3.75/7.5	0.18/0.35	4.5/9	0.21/0.43	5.4/10.8
Maximum Actuating Force	9,217 (lbs.)	41 (kN)	11,690 (lbs.)	52 (kN)	14,613 (lbs.)	65 (kN)	19,109 (lbs.)	85 (kN)
Clamping Force per Jaw	7,194 (lbs.)	32 (kN)	8,992 (lbs.)	40 (kN)	11,240 (lbs.)	50 (kN)	14,613 (lbs.)	65 (kN)
Total Clamping Force	21,582 (lbs.)	96 (kN)	26,977 (lbs.)	120 (kN)	33,721 (lbs.)	150 (kN)	43,838 (lbs.)	195 (kN)
Maximum RPM	4800		4000		3500		2800	
Weight*	44 (lbs.)	20 (kg)	66 (lbs.)	30 (kg)	132 (lbs.)	60 (kg)	249 (lbs.)	113 (kg)

*Chuck only. Does not include backplate or top jaws.

Royal MTC™ with Collet

	MTC-200		MTC-250		MTC-320		MTC-400	
	Inch	Metric	Inch	Metric	Inch	Metric	Inch	Metric
QG Collet Model	QG-52		QG-65		QG-80		QG-100	
Minimum Actuating Stroke	0.16	4	0.16	4	0.16	4	0.16	4
Maximum Actuating Force	9,217 (lbs.)	41 (kN)	10,116 (lbs.)	45 (kN)	11,240 (lbs.)	50 (kN)	14,613 (lbs.)	65 (kN)
Clamping Force	21,132 (lbs.)	94 (kN)	23,605 (lbs.)	105 (kN)	25,853 (lbs.)	115 (kN)	33,721 (lbs.)	150 (kN)
Maximum RPM	5500		4600		4000		3200	

Important: Please ensure that your machine's hydraulic actuator meets at least the minimum drawtube stroke requirements as outlined above. Also see warning on the preceding page to ensure that your specific actuator/input pressure achieves adequate dynamic clamping force to eliminate the risk of a workpiece becoming dislodged during use. If you have any questions or concerns regarding the safe use of this product, please contact one of our applications engineers at 1-800-645-4174.

ROYAL MTC™ MULTI-TASKING CHUCK

A TRUE ALL-IN-ONE CNC LATHE CHUCK



WHAT TO KNOW BEFORE YOU ORDER

In addition to the safety considerations regarding actuator force and drawtube stroke (highlighted on the previous pages), Royal may also require some specific dimensional information for your lathe to ensure that we supply the correct backplate and drawtube connector.

We maintain an extensive machine tool database populated with thousands actuator and drawtube specs, but sometimes changes/substitutions are made to the machine that we aren't aware of. **For safety purposes and to ensure a hassle-free installation experience, the information requested below may need to be supplied with your MTC™ order.** If you have any questions, please contact a Royal Products applications engineer at 1-800-645-4174.

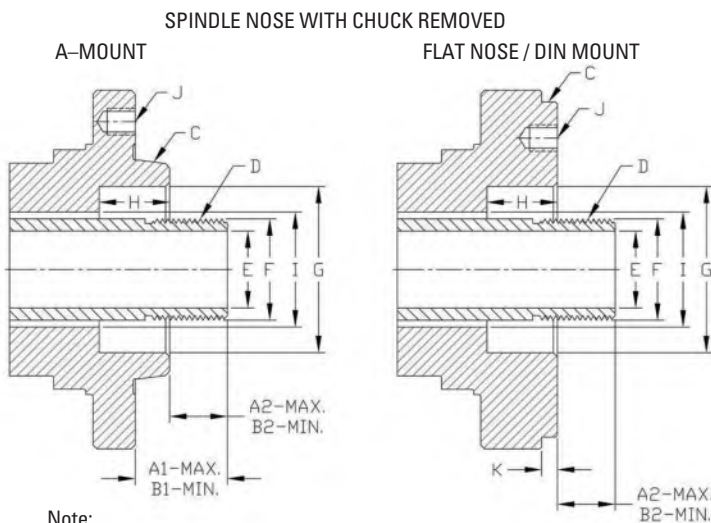

Note:
A drawtube sometimes unscrews from the actuator when the 3-jaw chuck is removed. Make sure drawtube is fully screwed in before taking dimensions.

Important – review your machine's tool interference diagram to ensure there are no interference issues with tool eye, parts catcher, guarding, etc.

Machine (make & model) _____
 Machine Serial Number _____
 Existing Chuck (make & Model) _____
 (if applicable)
 Actuator (make & model) _____
 Spindle - Main __ Sub __
 A1 – Max. (tube extended) _____
 B1 – Min. (tube retracted) _____
 A2 – Max. (tube extended) _____
 B2 – Min. (tube retracted) _____
 C-Spindle Type & Size _____
 (i.e. A2-6, 110mm, etc.)
 D-Drawtube Thread _____
 Pitch _____
 Internal or External _____
 Length of Thread _____

E – Drawtube I.D. _____
 F – Drawtube O.D. _____
 G – Counterbore I.D. _____
 H – Counterbore Length _____
 I – Spindle Through Hole Diameter _____
 J – Mounting Hole (DIN & A2-15 Spindles ONLY)
 Thread Size _____
 Quantity _____
 Spacing _____
 Ball Circle Diameter _____
 K – Pilot Length (DIN Spindles ONLY) _____
 Max. Actuator Pull Force* _____



ROYAL MTC™ MULTI-TASKING CHUCK

A TRUE ALL-IN-ONE CNC LATHE CHUCK

EASY SINGLE PART NUMBER ORDERING

The following items are included with every Royal MTC™ Multi-Tasking Chuck:

- ✓ A 3-Jaw chuck featuring industry standard 60°x1.5mm base jaws to accept a wide array of top jaws.
- ✓ A Quick-Grip™ center hub hardened and precision ground to accept Royal Quick-Grip™ Collets.
- ✓ A thru-hole center hub to accommodate long-parts when using as a jaw chuck
- ✓ A center cap to block chips from entering the drawtube when using the jaw chuck for slug work.
- ✓ A removable internal workstop for use with both jaws and collets.
- ✓ A center hub removal tool
- ✓ A grease gun and tube of chuck grease.
- ✓ A hardened and ground backplate to suit your particular lathe's spindle nose (not shown).
- ✓ A custom-machined drawtube connector for hassle-free installation



Royal MTC™ Multi-Tasking Chucks

Chuck Model	Spindle Type	Part Number	Price*
MTC-200	A2-5	51202	\$32,290
MTC-200	A2-6	51204	32,290
MTC-200	140 MM	51206	32,290
MTC-250	A2-6	51208	35,620
MTC-250	A2-8	51210	35,620
MTC-250	140 MM	51212	35,620
MTC-320	A2-8	51214	39,985
MTC-320	A2-11	51216	39,985
MTC-400	A2-8	51217	45,960
MTC-400	A2-11	51218	45,960
MTC-400	A2-15	51220	45,960

*Price includes a hardened and ground backplate up to 3" long. If your machine requires an extended backplate we will advise and quote a special plate.

ADDITIONAL ACCESSORIES

- The center hub for I.D. workholding is designed with a 75mm recess and is compatible with all Royal I.D. mandrels and sleeves (see full catalog for details).
- If you currently use a different brand of I.D. workholding, it may be possible for Royal to supply a custom center hub that would enable its use with the MTC – contact us to discuss.
- **The lifting/installation tool is highly recommended for fast and easy installation.** This device affixes to the chuck body in the same manner as the center hubs do, balancing the chuck's mass and enabling it to be easily threaded onto the machine's drawtube.



I.D. Center Hub



Lifting/Installation Tool

Royal MTC™ Accessories

Description	Fits Chuck Model	Part Number	Price
Center Hub for I.D. Workholding*	MTC-200	51230	\$4,270
	MTC-250	51231	4,590
	MTC-320	51232	5,520
	MTC-400	51233	8,540
Lifting/Installation Tool	MTC-200	51225	2,750
	MTC-250	51226	2,890
	MTC-320	51227	3,180
	MTC-400	51228	3,530

*Order mandrels and sleeves separately.