

MAGNETIC WORKHOLDING

Grinding | Pallet | Milling | EDM | Turning | Lifting

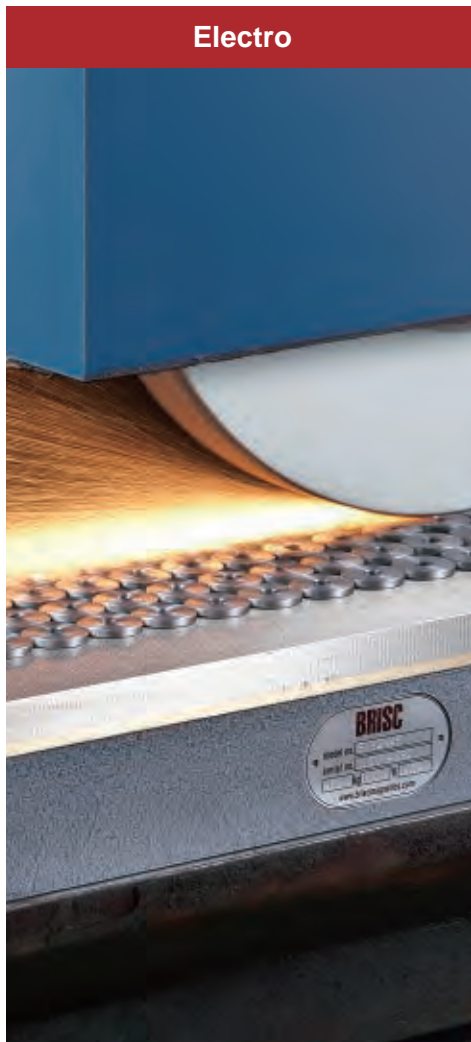
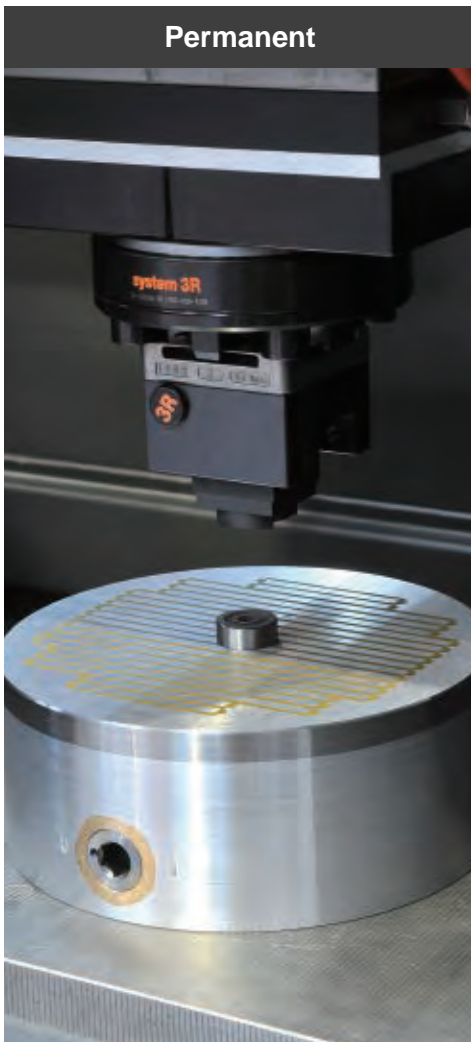

COMPLETE
METALWORKING
SOLUTIONS

(800) 991-4225

www.ahbinc.com

ISO Certified

customerservice@ahbinc.com

BRISC®

Magnetic Workholding Applications

Table of contents



Grinding

EMA	01
EPA	02
EPD	03
EME	04
EMV	05
EPB	06
EMM	07
EPM	08
EPS	09
EPN	10
PMF	11
PMT	12
PMA	13
EMK	14
EPZ	15

Pallet

PPN / PPA	16
PPC / PPM	17

Milling

EMI	18
PSP	19
POLE EXTENSION	20
PRP	21
PMM	22
PZP	23
PCC	24
EPK	26

EDM

PFD	27
MBF	28
NF	29
PMB	30
PMG	31

Turning

PMY	32
NY	33
EPY	34
NR	35
EMW	36
EPW	37
EMY	38
EPQ	39
PR	40

Lifting magnets

PLM	41
PLM-T	42
PLM-R	43
PHS / PVS	44

Control unit

CUA / CUD / CUT	45
CGA / CGD / JB	46
CU / CG / RMC	47
CEB / CUK	48

Tools & Magnets

PT SERIES	49
MB / MSA	55
MSB	56

Driven by magnetics

Soph offers the most comprehensive package of magnetic solutions for workholding, mold and die clamping and material handling. Starting the business in 1998, until now Soph owns the trademarks and business of Brisc, Magbo and Helmholtz which is for workholding, mold and die clamping and material handling respectively. Based in Hamburg Germany, after years of development, Soph now has branches in USA and China.

By installing one of the largest finished product inventories and training highly skilled service and sales engineers, Soph has created a substantial reference base in Europe, North America and Far east in a relatively short time. Our ability to provide immediate technical answers, immediate service, custom design, OEM specific products and product lines keeps us ahead of the curve.

With creative problem solving and application specific solutions, Soph is considered to be one of the finest sources for magnetic solutions available. We are dedicated to provide the best product with the best performance to match each application. By using customer input we are able to provide tailor made solutions using standardized products to create unmatched value in substantially shorter market cycles.

Products / Applications	Permanent	Electro	Electro-permanent
Grinding	PMF / PMT / PMA PMY / NY / PMM PFD / MBF / NF PMB / PMG / NR	EMA / EME / EMV EMM / EMK	EPA / EPB / EPD EPM / EPN / EPS EPW / EPZ
Pallet	PPA / PPC / PPM		PPN
Milling	PMM / NF / PMB PMG	EMI	EPK / PSP / PRP PZP / PCC
EDM	PFD / MBF / NF PMB / PMG / PMF PMT / PMY		
Turning	PMY / NY / NR NF	EMW / EMY	EPY / EPW / EPQ PR
Lifting	PLM / PLM-T / PLM-R PHS / PVS		



GRINDING



PALLET



MILLING



EDM



TURNING



LIFTING

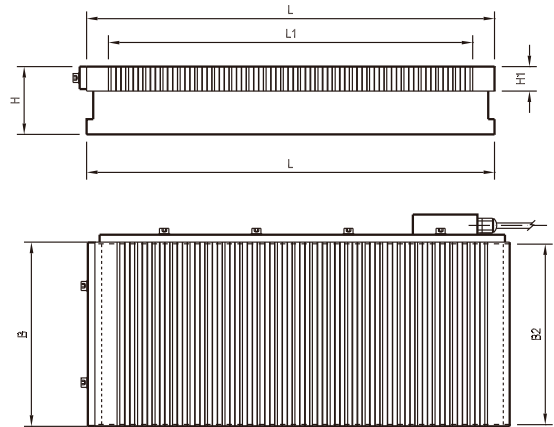

• Finepitch electromagnetic chuck

Use:

For versatile clamping on a broad range of workpiece sizes

Features:

- Pole pitch 5+0.5+5+0.5+5+3 mm
- Highest uniform clamping force up to 140 N/cm²
- Less than 5°C chuck temperature rise after 1 hour working
- Mono-block housing for maximum stability
- Low current with minimum power consumption
- Low profile for more wheel head clearance
- Versatile clamping, excellent holding on a broad range of workpiece size

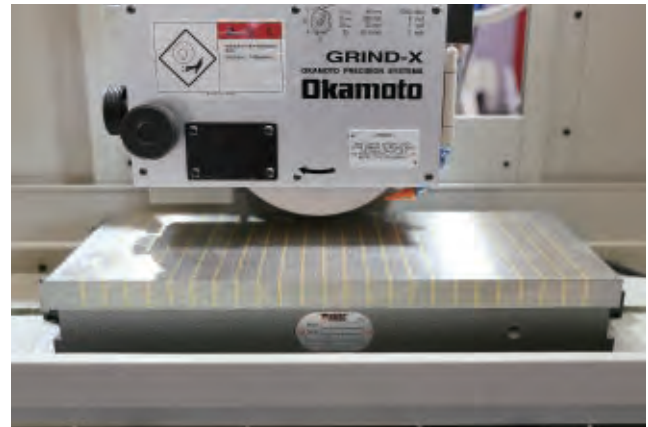

Model	Width(B)	Length(L)	Base Width(B2)	Height(H)	L1	H1	Voltage	Current	Net Weight
EMA-3060	300 (11.82)	600 (23.62)	294 (11.57)	80 (3.15)	554 (21.81)	27 (1.06)	110 V	0.78 A	107 kg / 236 lb
EMA-3080	300 (11.82)	800 (31.50)	294 (11.57)	80 (3.15)	744 (29.29)	27 (1.06)	110 V	1 A	143 kg / 315 lb
EMA-30100	300 (11.82)	1000 (39.37)	294 (11.57)	80 (3.15)	934 (36.77)	27 (1.06)	110 V	1.2 A	170 kg / 375 lb
EMA-30120	300 (11.82)	1200 (47.24)	294 (11.57)	80 (3.15)	1124 (44.25)	27 (1.06)	110 V	1.6 A	206 kg / 454 lb
EMA-30150	300 (11.82)	1500 (59.06)	294 (11.57)	80 (3.15)	1428 (56.22)	27 (1.06)	110 V	2.1 A	238 kg / 525 lb
EMA-4060	400 (15.75)	600 (23.62)	394 (15.51)	80 (3.15)	554 (21.81)	27 (1.06)	110 V	1.2 A	138 kg / 304 lb
EMA-4080	400 (15.75)	800 (31.50)	394 (15.51)	80 (3.15)	744 (29.29)	27 (1.06)	110 V	1.4 A	185 kg / 408 lb
EMA-40100	400 (15.75)	1000 (39.37)	394 (15.51)	80 (3.15)	934 (36.77)	27 (1.06)	110 V	1.9 A	230 kg / 507 lb
EMA-40120	400 (15.75)	1200 (47.24)	394 (15.51)	80 (3.15)	1124 (44.25)	27 (1.06)	110 V	2.2 A	276 kg / 608 lb
EMA-40150	400 (15.75)	1500 (59.06)	394 (15.51)	80 (3.15)	1428 (56.22)	27 (1.06)	110 V	2.5 A	350 kg / 771 lb
EMA-40200	400 (15.75)	1000 (39.37)*2	394 (15.51)	80 (3.15)	934 (36.22)*2	27 (1.06)	110 V	1.9 A*2	460 kg / 1014 lb
EMA-5060	500 (19.69)	600 (23.62)	494 (19.45)	80 (3.15)	554 (21.81)	27 (1.06)	110 V	1.2 A	170 kg / 375 lb
EMA-5080	500 (19.69)	800 (31.50)	494 (19.45)	80 (3.15)	744 (29.29)	27 (1.06)	110 V	1.5 A	212 kg / 466 lb
EMA-50100	500 (19.69)	1000 (39.37)	494 (19.45)	80 (3.15)	934 (36.77)	27 (1.06)	110 V	1.7 A	265 kg / 583 lb
EMA-50120	500 (19.69)	1200 (47.24)	494 (19.45)	80 (3.15)	1124 (44.25)	27 (1.06)	110 V	1.9 A	318 kg / 699 lb
EMA-50150	500 (19.69)	1500 (59.06)	494 (19.45)	80 (3.15)	1428 (56.22)	27 (1.06)	110 V	2.6 A	397 kg / 874 lb
EMA-50200	500 (19.69)	1000 (39.37)*2	494 (19.45)	80 (3.15)	934 (36.22)*2	27 (1.06)	110 V	1.7 A*2	530 kg / 1166 lb
EMA-6080	600 (23.62)	800 (31.50)	594 (23.39)	85 (3.35)	744 (29.29)	27 (1.06)	110 V	1.5 A	254 kg / 560 lb
EMA-60100	600 (23.62)	1000 (39.37)	594 (23.39)	85 (3.35)	934 (36.77)	27 (1.06)	110 V	2.2 A	318 kg / 699 lb
EMA-60120	600 (23.62)	1200 (47.24)	594 (23.39)	85 (3.35)	1124 (44.25)	27 (1.06)	110 V	2.4 A	382 kg / 839 lb
EMA-60150	600 (23.62)	1500 (59.06)	594 (23.39)	85 (3.35)	1428 (56.22)	27 (1.06)	110 V	2.4 A	477 kg / 1049 lb
EMA-60200	600 (23.62)	1000 (39.37)*2	594 (23.39)	85 (3.35)	934 (36.22)*2	27 (1.06)	110 V	2.2 A*2	636 kg / 1398 lb
EMA-70150	700 (27.56)	1500 (59.06)	694 (27.32)	85 (3.35)	1428 (56.22)	27 (1.06)	110 V	2.4 A	556 kg / 1224 lb
EMA-80200	800 (31.50)	1000 (39.37)*2	794 (31.25)	85 (3.35)	934 (36.22)*2	27 (1.06)	110 V	2.9 A*2	848 kg / 1866 lb
EMA-100150	1000 (39.37)	1500 (59.06)	994 (39.13)	85 (3.35)	1428 (56.22)	27 (1.06)	110 V	5 A*2	848 kg / 1866 lb
EMA-100200	1000 (39.37)	1000 (39.37)*2	994 (39.13)	85 (3.35)	934 (36.22)*2	27 (1.06)	110 V	3.3 A*2	1130 kg / 2487 lb
EMA-120200	1200 (47.24)	1000 (39.37)*2	1194 (47.01)	85 (3.35)	934 (36.22)*2	27 (1.06)	110 V	4 A*2	1356 kg / 2984 lb
EMA-120300	1200 (47.24)	1000 (39.37)*3	1194 (47.01)	85 (3.35)	934 (36.22)*3	27 (1.06)	110 V	4 A*3	2035 kg / 4476 lb
EMA-150300	1500 (59.06)	1000 (39.37)*3	1494 (52.82)	85 (3.35)	934 (36.22)*3	27 (1.06)	110 V	6.5 A*3	2543 kg / 5595 lb
EMA-150500	1500 (59.06)	1000 (39.37)*5	1492 (52.82)	85 (3.35)	934 (36.22)*5	27 (1.06)	110 V	6.5 A*5	2852 kg / 6287 lb

Unit: mm(in)

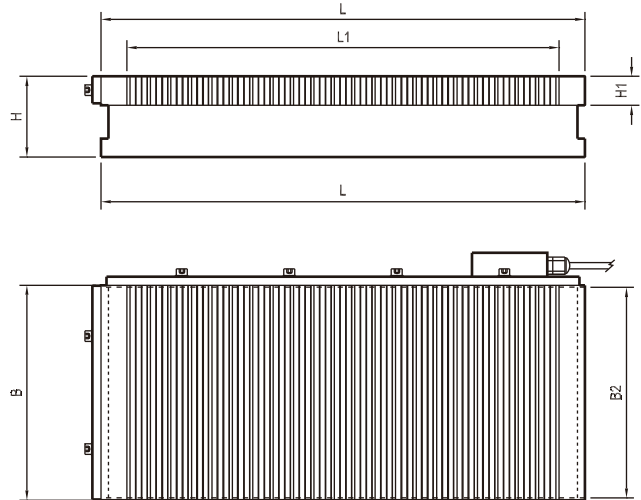

Grinding

● Finepitch electro-permanent magnetic chuck

Use:

For versatile clamping on a broad range of workpiece sizes

Features:

- Pole pitch 5+0.5+5+0.5+5+3 mm
- Highest uniform clamping force up to 140 N/cm²
- Electro-permanent magnetic technology with no deformation owing to the rise of temperature
- Can eliminate residual magnetism from the workpiece
- Coolant and water proof structure
- Mono-block housing for maximum stability



Model	Width(B)	Length(L)	Base Width(B2)	Height(H)	L1	H1	Net Weight	Controller (400V)
EPA-50100	500 (19.70)	1000 (39.40)	498 (19.62)	75 (2.95)	934 (36.77)	27 (1.06)	265 kg / 583 lb	CGA
EPA-50120	500 (19.70)	1200 (47.28)	498 (19.62)	75 (2.95)	1124 (44.25)	27 (1.06)	318 kg / 699 lb	CGA
EPA-50150	500 (19.70)	1500 (59.10)	498 (19.62)	75 (2.95)	1428 (56.22)	27 (1.06)	397 kg / 874 lb	CGD
EPA-50200	500 (19.70)	1000 (39.37)*2	498 (19.62)	75 (2.95)	934 (36.77)	27 (1.06)	530 kg / 1166 lb	CGD
EPA-6080	600 (23.64)	800 (31.52)	598 (23.56)	75 (2.95)	744 (30.47)	27 (1.06)	254 kg / 560 lb	CGA
EPA-60100	600 (23.64)	1000 (39.40)	598 (23.56)	75 (2.95)	934 (36.77)	27 (1.06)	318 kg / 699 lb	CGD
EPA-60120	600 (23.64)	1200 (47.28)	598 (23.56)	75 (2.95)	1124 (44.25)	27 (1.06)	382 kg / 839 lb	CGD
EPA-60150	600 (23.64)	1500 (59.10)	598 (23.56)	75 (2.95)	1428 (56.22)	27 (1.06)	477 kg / 1049 lb	CGD
EPA-60200	600 (23.64)	1000 (39.37)*2	598 (23.56)	75 (2.95)	934 (36.77)	27 (1.06)	636 kg / 1398 lb	CGF
EPA-60220	600 (23.64)	1100 (43.30)*2	598 (23.56)	75 (2.95)	1048 (41.26)	27 (1.06)	740 kg / 1631 lb	CGF
EPA-60250	600 (23.64)	1250 (49.21)*2	598 (23.56)	75 (2.95)	1184 (46.61)	27 (1.06)	841 kg / 1854 lb	CGF
EPA-70150	700 (27.58)	1500 (59.10)	698 (27.50)	75 (2.95)	1428 (56.22)	27 (1.06)	477 kg / 1049 lb	CGF
EPA-75150	750 (29.55)	1500 (59.10)	748 (29.47)	75 (2.95)	1428 (56.22)	27 (1.06)	631 kg / 1391 lb	CGF

Unit: mm(in)

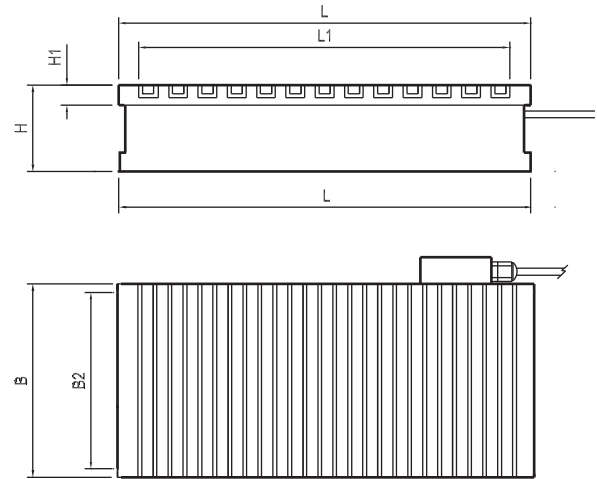

● **Standard pitch electro-permanent magnetic chuck**

Use:

For universal clamping with higher magnetic force

Features:

- Pole pitch 3+15 mm
- Highest clamping force up to 160 N/cm²
- Electro-permanent technology with no deformation owing to the rise of the temperature
- Can eliminate the residual magnetism from the workpiece
- Solid top plate with high precision
- Minimum mechanical deformation with solid one-piece housing

Model	Width (B)	Length (L)	B2	Height	L1	H1	Controller (400V)	Net Weight
EPD-1530	150 (5.91)	300 (11.81)	146 (5.75)	80 (3.15)	237 (9.33)	25 (0.98)	CGA	25 kg / 55 lb
EPD-1535	150 (5.91)	350 (13.78)	146 (5.75)	80 (3.15)	291 (11.46)	25 (0.98)	CGA	29 kg / 64 lb
EPD-1540	150 (5.91)	400 (15.75)	146 (5.75)	80 (3.15)	345 (13.58)	25 (0.98)	CGA	34 kg / 75 lb
EPD-1545	150 (5.91)	450 (17.72)	146 (5.75)	80 (3.15)	381 (15.00)	25 (0.98)	CGA	38 kg / 84 lb
EPD-2040	200 (7.87)	400 (15.75)	196 (7.72)	80 (3.15)	345 (13.58)	25 (0.98)	CGA	45 kg / 99 lb
EPD-2045	200 (7.87)	450 (15.75)	196 (7.72)	80 (3.15)	381 (15.00)	25 (0.98)	CGA	51 kg / 112 lb
EPD-2050	200 (7.87)	500 (19.69)	196 (7.72)	80 (3.15)	435 (17.13)	25 (0.98)	CGA	56 kg / 123 lb
EPD-2550	250 (9.84)	500 (19.69)	246 (9.69)	80 (3.15)	435 (17.13)	25 (0.98)	CGA	70 kg / 154 lb
EPD-3060	300 (11.81)	600 (23.62)	296 (11.65)	80 (3.15)	543 (21.38)	25 (0.98)	CGA	101 kg / 222 lb
EPD-4080	400 (15.75)	800 (31.50)	396 (15.59)	80 (3.15)	741 (29.17)	25 (0.98)	CGA	179 kg / 394 lb
EPD-40100	400 (15.75)	1000 (39.37)	396 (15.59)	80 (3.15)	939 (36.97)	25 (0.98)	CGA	238 kg / 524 lb
EPD-40150	400 (15.75)	1500 (59.05)	396 (15.59)	80 (3.15)	1443 (56.81)	25 (0.98)	CGA	357 kg / 787 lb
EPD-5080	500 (19.69)	800 (31.50)	496 (19.53)	80 (3.15)	741 (29.17)	25 (0.98)	CGA	238 kg / 524 lb
EPD-50100	500 (19.69)	1000 (39.37)	496 (19.53)	80 (3.15)	939 (36.97)	25 (0.98)	CGA	280 kg / 616 lb
EPD-50150	500 (19.69)	1500 (59.05)	496 (19.53)	80 (3.15)	1443 (56.81)	25 (0.98)	CGA	447 kg / 985 lb
EPD-50200	500 (19.69)	1000 (39.37)*2	496 (19.53)	80 (3.15)	939 (36.97)*2	25 (0.98)	CGD	560 kg / 1234 lb
EPD-6080	600 (23.62)	800 (31.50)	596 (23.46)	80 (3.15)	741 (29.17)	25 (0.98)	CGA	269 kg / 592 lb
EPD-60100	600 (23.62)	1000 (39.37)	596 (23.46)	80 (3.15)	939 (36.97)	25 (0.98)	CGA	357 kg / 787 lb
EPD-60150	600 (23.62)	1500 (59.05)	596 (23.46)	80 (3.15)	1443 (56.81)	25 (0.98)	CGA	508 kg / 1120 lb
EPD-60200	600 (23.62)	1000 (39.37)*2	596 (23.46)	80 (3.15)	939 (36.97)*2	25 (0.98)	CGD	672 kg / 1478 lb

Unit: mm(in)

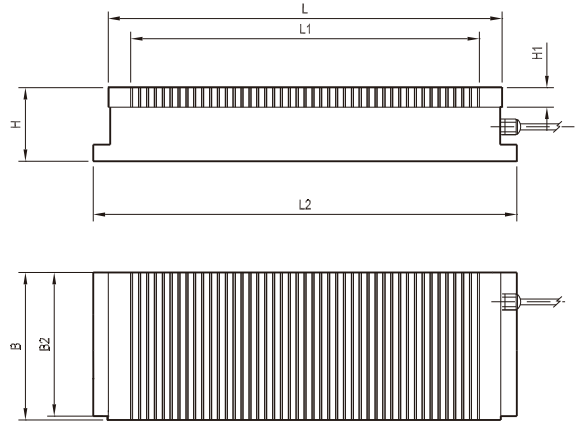

Grinding

● Micropitch electromagnetic chuck with transverse poles

Use:

Clamping of transverse placed thin plate shaped workpieces

Features:

- EME with pole pitch 0.5+1.5 mm
- Highest uniform clamping force up to 120 N/cm²
- Top plate with micropitch transverse lamination
- Flux depth of only 4 mm
- Mono-block housing for maximum stability



Model	Width (B)	Length (L)	Base Width (B2)	Base Length (L2)	Height (H)	L1	H1	Voltage	Current	Net Weight
EME-1525	150 (5.91)	250 (9.85)	148 (5.83)	270 (10.63)	75 (2.95)	214 (8.43)	20 (0.79)	110 V	0.72 A	19 kg / 42 lb
EME-1530	150 (5.91)	300 (11.82)	148 (5.83)	320 (12.60)	75 (2.95)	264 (10.40)	20 (0.79)	110 V	0.62 A	23 kg / 51 lb
EME-1535	150 (5.91)	350 (13.79)	148 (5.83)	370 (11.57)	75 (2.95)	314 (12.37)	20 (0.79)	110 V	0.80 A	27 kg / 59 lb
EME-1540	150 (5.91)	400 (15.76)	148 (5.83)	420 (16.54)	75 (2.95)	364 (14.34)	20 (0.79)	110 V	0.70 A	31 kg / 68 lb
EME-1545	150 (5.91)	450 (17.73)	148 (5.83)	470 (18.50)	75 (2.95)	414 (16.31)	20 (0.79)	110 V	1.00 A	34 kg / 75 lb
EME-1840	180 (7.09)	400 (15.76)	178 (7.01)	420 (16.54)	75 (2.95)	364 (14.34)	20 (0.79)	110 V	0.94 A	37 kg / 81 lb
EME-2040	200 (7.88)	400 (15.76)	198 (7.80)	420 (16.54)	75 (2.95)	364 (14.34)	20 (0.79)	110 V	1.00 A	41 kg / 90 lb
EME-2045	200 (7.88)	450 (17.73)	198 (7.80)	470 (18.50)	75 (2.95)	414 (16.31)	20 (0.79)	110 V	1.10 A	46 kg / 101 lb
EME-2050	200 (7.88)	500 (19.70)	198 (7.80)	520 (20.47)	75 (2.95)	440 (17.34)	20 (0.79)	110 V	1.30 A	51 kg / 112 lb
EME-2060	200 (7.88)	600 (23.64)	198 (7.80)	620 (24.41)	75 (2.95)	554 (21.83)	20 (0.79)	110 V	1.10 A	61 kg / 134 lb
EME-2550	250 (9.85)	500 (19.70)	248 (9.77)	520 (20.47)	75 (2.95)	440 (17.34)	20 (0.79)	110 V	1.70 A	64 kg / 141 lb
EME-2560	250 (9.85)	600 (23.64)	248 (9.77)	620 (24.41)	75 (2.95)	554 (21.83)	20 (0.79)	110 V	1.90 A	77 kg / 169 lb
EME-3060	300 (11.82)	600 (23.64)	298 (11.74)	620 (24.41)	75 (2.95)	554 (21.83)	20 (0.79)	110 V	1.90 A	94 kg / 207 lb
EME-4080	400 (15.76)	800 (31.52)	398 (15.68)	820 (32.28)	75 (2.95)	745 (29.33)	20 (0.79)	110 V	2.80 A	171 kg / 376 lb
EME-5080	500 (19.70)	800 (31.52)	498 (19.62)	820 (32.28)	75 (2.95)	745 (29.33)	20 (0.79)	110 V	3.20 A	210 kg / 462 lb

Unit: mm(in)

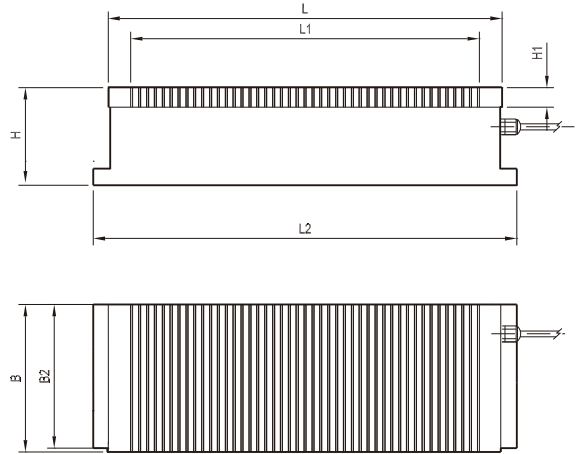

● **Micropitch electromagnetic chuck with transverse poles**

Use:

Clamping of transverse placed thin plate shaped workpieces

Features:

- EMV with pole pitch 0.5+1.5 mm
- Highest uniform clamping force up to 120 N/cm²
- Top plate with micropitch transverse lamination
- Flux depth of only 4 mm
- Mono-block housing for maximum stability
- Low current with minimum power consumption



Model	Width (B)	Length (L)	Base Width (B2)	Base Length (L2)	Height (H)	L1	H1	Voltage	Current	Net Weight
EMV-1525	150 (5.91)	250 (9.85)	148 (5.83)	270 (10.63)	110 (4.33)	214 (8.43)	20 (0.79)	110 V	0.40 A	30 kg / 66 lb
EMV-1530	150 (5.91)	300 (11.82)	148 (5.83)	320 (12.60)	110 (4.33)	264 (10.40)	20 (0.79)	110 V	0.36 A	36 kg / 79 lb
EMV-1535	150 (5.91)	350 (13.79)	148 (5.83)	370 (11.57)	110 (4.33)	314 (12.37)	20 (0.79)	110 V	0.48 A	42 kg / 92 lb
EMV-1540	150 (5.91)	400 (15.76)	148 (5.83)	420 (16.54)	110 (4.33)	364 (14.34)	20 (0.79)	110 V	0.42 A	52 kg / 114 lb
EMV-1545	150 (5.91)	450 (17.73)	148 (5.83)	470 (18.50)	110 (4.33)	414 (16.31)	20 (0.79)	110 V	0.60 A	55 kg / 121 lb
EMV-1840	180 (7.09)	400 (15.76)	178 (7.01)	420 (16.54)	110 (4.33)	364 (14.34)	20 (0.79)	110 V	0.55 A	58 kg / 127 lb
EMV-2040	200 (7.88)	400 (15.76)	198 (7.80)	420 (16.54)	110 (4.33)	364 (14.34)	20 (0.79)	110 V	0.60 A	66 kg / 145 lb
EMV-2045	200 (7.88)	450 (17.73)	198 (7.80)	470 (18.50)	110 (4.33)	414 (16.31)	20 (0.79)	110 V	0.66 A	76 kg / 167 lb
EMV-2050	200 (7.88)	500 (19.70)	198 (7.80)	520 (20.47)	110 (4.33)	440 (17.34)	20 (0.79)	110 V	0.78 A	82 kg / 180 lb
EMV-2060	200 (7.88)	600 (23.64)	198 (7.80)	620 (24.41)	110 (4.33)	554 (21.83)	20 (0.79)	110 V	0.66 A	98 kg / 216 lb
EMV-2550	250 (9.85)	500 (19.70)	248 (9.77)	520 (20.47)	110 (4.33)	440 (17.34)	20 (0.79)	110 V	1.00 A	102 kg / 224 lb
EMV-2560	250 (9.85)	600 (23.64)	248 (9.77)	620 (24.41)	110 (4.33)	554 (21.83)	20 (0.79)	110 V	1.14 A	123 kg / 271 lb
EMV-3060	300 (11.82)	600 (23.64)	298 (11.74)	620 (24.41)	110 (4.33)	554 (21.83)	20 (0.79)	110 V	1.14 A	156 kg / 343 lb
EMV-4080	400 (15.76)	800 (31.52)	398 (15.68)	820 (32.28)	110 (4.33)	745 (29.33)	20 (0.79)	110 V	1.70 A	262 kg / 577 lb
EMV-5080	500 (19.70)	800 (31.52)	498 (19.62)	820 (32.28)	110 (4.33)	745 (29.33)	20 (0.79)	110 V	1.90 A	328 kg / 723 lb

Unit: mm(in)

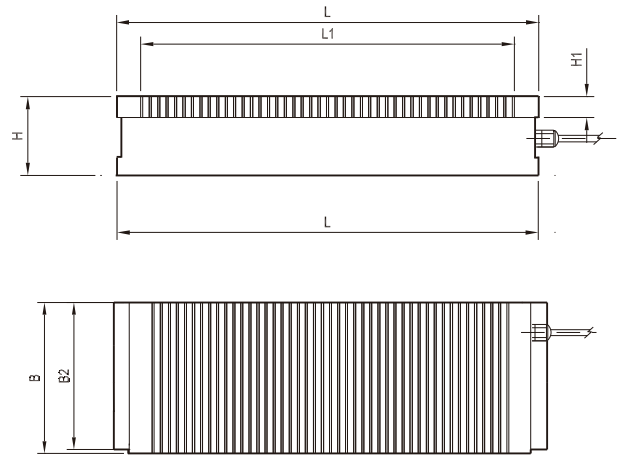

Grinding

• Mirropitch electro-permanent magnetic chuck with transverse poles

Use:

Clamping of transverse placed thin plate shaped workpieces

Features:

- EPB with pole pitch 1+3 mm
- Highest uniform clamping force up to 120 N/cm²
- Electro-permanent technology with no deformation owing to the rise of temperature
- Can eliminate residual magnetism from the workpiece
- Coolant and water proof structure
- Minimum mechanical deformation with solid one-piece housing

Model	Width (B)	Length (L)	Base Width (B2)	Height (H)	L1	H1	Net Weight	Controller (400V)	Controller (220V)
EPB-1525	150 (5.91)	250 (9.85)	148 (5.83)	75 (2.95)	214 (8.43)	20 (0.79)	21 kg / 46 lb	CGA	CGA
EPB-1530	150 (5.91)	300 (11.82)	148 (5.83)	75 (2.95)	264 (10.40)	20 (0.79)	25 kg / 55 lb	CGA	CGA
EPB-1535	150 (5.91)	350 (13.79)	148 (5.83)	75 (2.95)	314 (12.37)	20 (0.79)	29 kg / 64 lb	CGA	CGA
EPB-1540	150 (5.91)	400 (15.76)	148 (5.83)	75 (2.95)	364 (14.34)	20 (0.79)	36 kg / 79 lb	CGA	CGA
EPB-1545	150 (5.91)	450 (17.73)	148 (5.83)	75 (2.95)	414 (16.31)	20 (0.79)	38 kg / 84 lb	CGA	CGA
EPB-1840	180 (7.09)	400 (15.76)	178 (7.01)	75 (2.95)	364 (14.34)	20 (0.79)	40 kg / 88 lb	CGA	CGA
EPB-2040	200 (7.88)	400 (15.76)	198 (7.80)	75 (2.95)	364 (14.34)	20 (0.79)	45 kg / 99 lb	CGA	CGA
EPB-2045	200 (7.88)	450 (17.73)	198 (7.80)	75 (2.95)	414 (16.31)	20 (0.79)	52 kg / 114 lb	CGA	CGA
EPB-2050	200 (7.88)	500 (19.70)	198 (7.80)	75 (2.95)	464 (18.27)	20 (0.79)	56 kg / 123 lb	CGA	CGA
EPB-2060	200 (7.88)	600 (23.64)	198 (7.80)	75 (2.95)	564 (22.20)	20 (0.79)	67 kg / 148 lb	CGA	CGA
EPB-2550	250 (9.85)	500 (19.70)	248 (9.77)	75 (2.95)	464 (18.27)	20 (0.79)	70 kg / 154 lb	CGA	CGA
EPB-2560	250 (9.85)	600 (23.64)	248 (9.77)	75 (2.95)	564 (22.20)	20 (0.79)	84 kg / 185 lb	CGA	CGA
EPB-3060	300 (11.82)	600 (23.64)	298 (11.74)	75 (2.95)	564 (22.20)	20 (0.79)	107 kg / 236 lb	CGA	CGA
EPB-3080	300 (11.82)	800 (31.52)	298 (11.74)	75 (2.95)	764 (30.08)	20 (0.79)	143 kg / 315 lb	CGA	CGA
EPB-30100	300 (11.82)	1000 (39.40)	298 (11.74)	75 (2.95)	964 (37.95)	20 (0.79)	170 kg / 375 lb	CGA	CGA
EPB-30120	300 (11.82)	1200 (47.28)	298 (11.74)	75 (2.95)	1164 (45.83)	20 (0.79)	206 kg / 454 lb	CGA	CGA
EPB-4060	400 (15.76)	600 (23.64)	398 (15.68)	75 (2.95)	564 (22.20)	20 (0.79)	134 kg / 295 lb	CGA	CGA
EPB-4080	400 (15.76)	800 (31.52)	398 (15.68)	75 (2.95)	764 (30.08)	20 (0.79)	238 kg / 525 lb	CGA	CGA

Unit: mm(in)



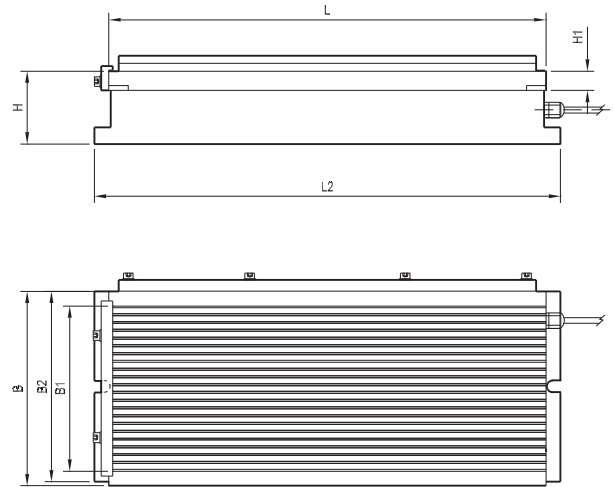

● micropitch electromagnetic chuck with longitudinal poles

Use:

Clamping of longitudinal placed thin plate shaped workpieces

Features:

- EMM with pole pitch 1+3 mm
- Highest uniform clamping force up to 120 N/cm²
- Top plate with micropitch longitudinal lamination
- Full surface magnetic power
- Low magnetic field height of only 4 mm
- Minimum mechanical deformation with solid one-piece housing
- Low current with minimum power consumption

Model	Width(B)	Length(L)	B2	L2	Height(H)	B1	H1	Voltage	Current	Net Weight
EMM-1530	150 (5.91)	300 (11.81)	148 (5.83)	330 (12.99)	75 (2.95)	117 (4.61)	20 (0.79)	90 - 110V	0.6 A	23 kg / 51 lb
EMM-1535	150 (5.91)	350 (13.78)	148 (5.83)	380 (14.96)	75 (2.95)	117 (4.61)	20 (0.79)	90 - 110V	0.7 A	27 kg / 59 lb
EMM-1540	150 (5.91)	400 (15.75)	148 (5.83)	430 (16.93)	75 (2.95)	117 (4.61)	20 (0.79)	90 - 110V	0.8 A	31 kg / 68 lb
EMM-1545	150 (5.91)	450 (17.72)	148 (5.83)	480 (18.90)	75 (2.95)	117 (4.61)	20 (0.79)	90 - 110V	0.9 A	34 kg / 75 lb
EMM-2040	200 (7.87)	400 (15.75)	198 (7.80)	430 (16.93)	75 (2.95)	165 (6.50)	20 (0.79)	90 - 110V	1.0 A	41 kg / 90 lb
EMM-2045	200 (7.87)	450 (17.72)	198 (7.80)	480 (18.90)	75 (2.95)	165 (6.50)	20 (0.79)	90 - 110V	1.2 A	46 kg / 101 lb
EMM-2050	200 (7.87)	500 (19.69)	198 (7.80)	530 (20.87)	75 (2.95)	165 (6.50)	20 (0.79)	90 - 110V	1.5 A	51 kg / 112 lb
EMM-2550	250 (9.84)	500 (19.69)	248 (9.76)	530 (20.87)	75 (2.95)	214 (8.43)	20 (0.79)	90 - 110V	1.7 A	64 kg / 141 lb
EMM-3060	300 (11.81)	600 (23.62)	298 (11.73)	630 (24.80)	75 (2.95)	260 (10.24)	20 (0.79)	90 - 110V	1.9 A	94 kg / 207 lb
EMM-4080	400 (15.75)	800 (31.50)	398 (15.67)	830 (32.68)	75 (2.95)	354 (13.94)	20 (0.79)	90 - 110V	2.8 A	171 kg / 376 lb

Unit: mm(in)

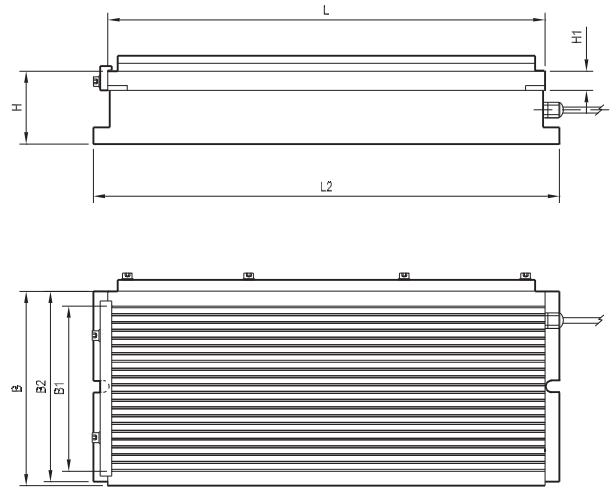

● **Micropitch electro-permanent magnetic chuck with longitudinal poles**

Use:

Clamping of longitudinal placed thin plate shaped workpieces

Features:

- EPM with pole pitch 1+3 mm
- Highest uniform clamping force up to 120 N/cm²
- Electro-permanent magnetic technology with no deformation owing to the rise of temperature
- Top plate with micropitch longitudinal lamination
- Full surface magnetic power
- Minimum mechanical deformation with solid one-piece housing

Model	Width(B)	Length(L)	B2	L2	Height(H)	B1	H1	Controller (400V)	Controller (220V)	Net Weight
EPM-1530	150 (5.91)	300 (11.81)	148 (5.83)	330 (12.99)	75 (2.95)	117 (4.61)	20 (0.79)	CGA	CGA	23 kg / 51 lb
EPM-1535	150 (5.91)	350 (13.78)	148 (5.83)	380 (14.96)	75 (2.95)	117 (4.61)	20 (0.79)	CGA	CGA	27 kg / 59 lb
EPM-1540	150 (5.91)	400 (15.75)	148 (5.83)	430 (16.93)	75 (2.95)	117 (4.61)	20 (0.79)	CGA	CGA	31 kg / 68 lb
EPM-1545	150 (5.91)	450 (17.72)	148 (5.83)	480 (18.90)	75 (2.95)	117 (4.61)	20 (0.79)	CGA	CGA	34 kg / 75 lb
EPM-2040	200 (7.87)	400 (15.75)	198 (7.80)	430 (16.93)	75 (2.95)	165 (6.50)	20 (0.79)	CGA	CGA	41 kg / 90 lb
EPM-2045	200 (7.87)	450 (17.72)	198 (7.80)	480 (18.90)	75 (2.95)	165 (6.50)	20 (0.79)	CGA	CGA	46 kg / 101 lb
EPM-2050	200 (7.87)	500 (19.69)	198 (7.80)	530 (20.87)	75 (2.95)	165 (6.50)	20 (0.79)	CGA	CGA	51 kg / 112 lb
EPM-2550	250 (9.84)	500 (19.69)	248 (9.76)	530 (20.87)	75 (2.95)	214 (8.43)	20 (0.79)	CGA	CGA	64 kg / 141 lb
EPM-3060	300 (11.81)	600 (23.62)	298 (11.73)	630 (24.80)	75 (2.95)	260 (10.24)	20 (0.79)	CGA	CGA	94 kg / 207 lb
EPM-4080	400 (15.75)	800 (31.50)	398 (15.67)	830 (32.68)	75 (2.95)	354 (13.94)	20 (0.79)	CGA	CGA	171 kg / 376 lb

Unit: mm(in)



• Square pole electro-permanent magnetic chuck with standard density

Use:

Clamping for grinding of medium to large work pieces

Features:

- Full metallic surface, no resin, coolant and water proof
- Square pole size 50x50 mm
- Magnetic force higher than 200 kg per pole
- Electro-permanent magnetic technology with no deformation owing to the rise of temperature
- Distortion free clamping with auto-shim pole extensions
- No residual magnetism
- Workpiece larger than the table size are possible
- Multiple magnet combinations can provide clamping for larger sizes
- Magnetic flux depth 12.5 mm



ES-5052 Fix pole extensions

ES fixed and ET self shimming pole extensions using the built in threaded rod which does not require tools to install or remove.

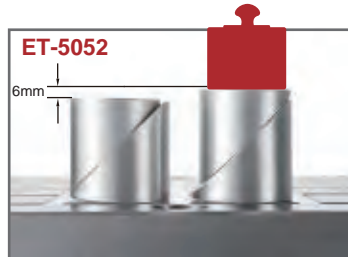

ET-5052 Mobile pole extensions

The new and improved ET pole extension has increased the performance of the original ET by 20%. Total adjustment is 6 mm.

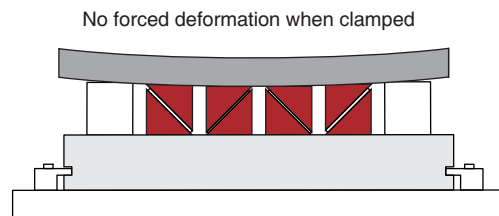
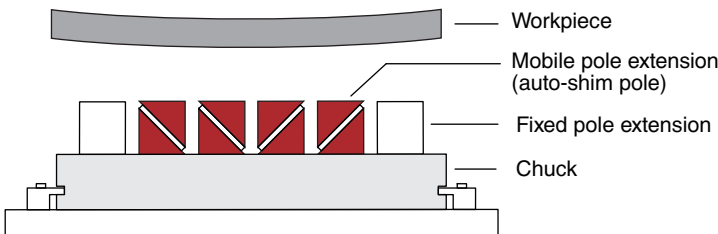

Model	Width	Length	Height	Pole No.	Controller (400/480V)	Controller (220V)	Net Weight
EPS-3049	300 (11.82)	490 (19.29)	59 (2.32)	24	CGA	CGA	75 kg / 165 lb
EPS-3064	300 (11.82)	640 (25.20)	59 (2.32)	32	CGA	CGA	98 kg / 216 lb
EPS-3649	360 (14.17)	490 (19.29)	59 (2.32)	30	CGA	CGA	78 kg / 172 lb
EPS-3664	360 (14.17)	640 (25.20)	59 (2.32)	40	CGA	CGA	101 kg / 222 lb
EPS-3679	360 (14.17)	790 (31.10)	59 (2.32)	50	CGA	CGA	125 kg / 276 lb
EPS-4279	420 (16.54)	790 (31.10)	59 (2.32)	60	CGA	CGD	146 kg / 322 lb
EPS-4894	480 (18.90)	940 (37.00)	59 (2.32)	84	CGA	CGD	199 kg / 439 lb
EPS-48109	480 (18.90)	1090 (42.91)	59 (2.32)	98	CGD	CGD	230 kg / 507 lb
EPS-5494	540 (21.26)	940 (37.00)	59 (2.32)	96	CGD	CGD	258 kg / 569 lb
EPS-54109	540 (21.26)	1090 (42.91)	59 (2.32)	112	CGD	CGD	300 kg / 661 lb
EPS-60139	600 (23.62)	1390 (54.72)	59 (2.32)	162	CGD	CGF	367 kg / 809 lb
EPS-60154	600 (23.62)	1540 (60.63)	59 (2.32)	180	CGF	CGF	407 kg / 897lb
EPS-66139	660 (25.98)	1390 (54.72)	59 (2.32)	170	CGF	CGF	404 kg / 899lb
EPS-66154	660 (25.98)	1540 (60.63)	59 (2.32)	188	CGF	CGF	450 kg / 992lb

Unit: mm(in)



Grinding

● Full metallic electro-permanent magnetic chuck

Use:

Clamping for grinding of small or thin work pieces

Features:

- Full metallic surface, no resin, coolant and water proof
- Highest clamping force up to 120 N/cm²
- Electro-permanent magnetic technology with no deformation owing to the rise of temperature
- No residual magnetism
- Workpiece larger than the table size are possible
- Multiple magnet combinations can provide clamping for larger sizes
- Magnetic flux depth 10 mm



Model	Width	Length	Height	Pole No.	Controller (400)	Net Weight
EPN-2142	210 (8.27)	415 (16.34)	40 (1.57)	50	CGA	26 kg / 57 lb
EPN-2145	210 (8.27)	452 (17.80)	40 (1.57)	55	CGA	28 kg / 62 lb
EPN-2149	210 (8.27)	489 (19.25)	40 (1.57)	60	CGA	30 kg / 66 lb
EPN-2153	210 (8.27)	526 (20.71)	40 (1.57)	65	CGA	33 kg / 73 lb
EPN-2156	210 (8.27)	563 (22.17)	40 (1.57)	70	CGA	35 kg / 77 lb
EPN-2160	210 (8.27)	600 (23.62)	40 (1.57)	75	CGA	37 kg / 82 lb
EPN-2549	247 (9.72)	489 (19.25)	40 (1.57)	72	CGA	36 kg / 79 lb
EPN-2553	247 (9.72)	526 (20.71)	40 (1.57)	78	CGA	38.5 kg / 85 lb
EPN-2556	247 (9.72)	563 (22.17)	40 (1.57)	84	CGA	41.5kg / 93 lb
EPN-2560	247 (9.72)	600 (23.62)	40 (1.57)	90	CGA	44 kg / 97 lb
EPN-2853	284 (11.18)	526 (20.71)	40 (1.57)	91	CGA	44.5 kg / 98 lb
EPN-2856	284 (11.18)	563 (22.17)	40 (1.57)	98	CGA	47.5 kg / 105 lb
EPN-2860	284 (11.18)	600 (23.62)	40 (1.57)	105	CGA	51 kg / 112 lb
EPN-3256	321 (12.64)	563 (22.17)	40 (1.57)	112	CGA	54 kg / 119 lb
EPN-3260	321 (12.64)	600 (23.62)	40 (1.57)	120	CGA	57.5 kg / 127 lb

Unit: mm(in)

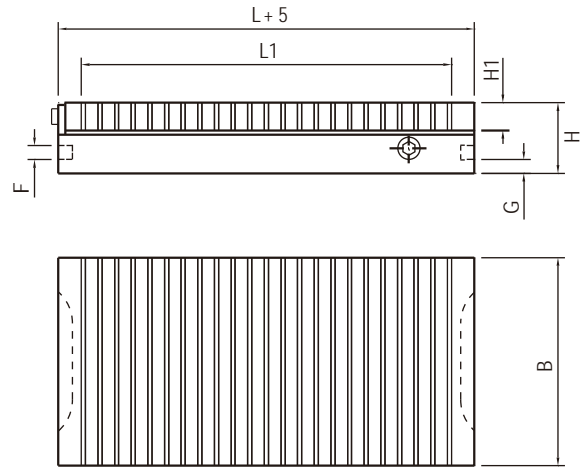

• Permanent magnetic chuck

Use:

General purpose low profile grinding magnet

Features:

- PMF with pole pitch 0.5+1.5 mm
- Highest uniform magnetic clamping force up to 120 N/cm²
- Coolant and water proof structure
- Easy to activate and de-activate
- High precision with no residual magnetism

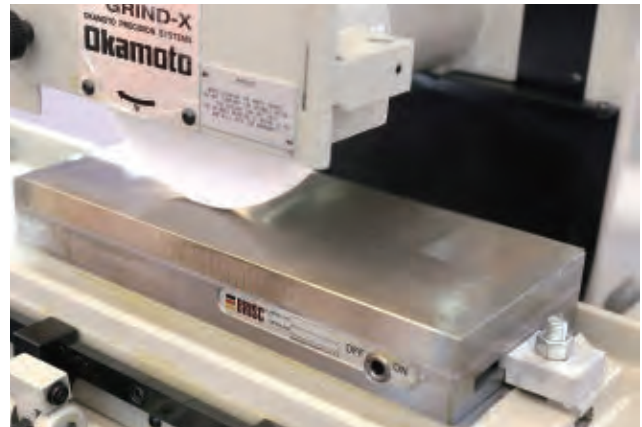

Model	Width(B)	Length(L)	Height(H)	L1	H1	F	G	Net Weight
PMF-0713	70 (2.76)	130 (5.12)	49 (1.93)	101 (3.98)	20 (0.79)	10 (0.39)	10 (0.39)	3 kg / 8 lb
PMF-10175	100 (3.94)	175 (6.90)	49 (1.93)	140 (5.51)	20 (0.79)	10 (0.39)	10 (0.39)	7 kg / 15 lb
PMF-1025	100 (3.94)	250 (9.84)	49 (1.93)	206 (8.11)	20 (0.79)	10 (0.39)	10 (0.39)	10 kg / 21 lb
PMF-1325	130 (5.12)	255 (10.03)	49 (1.93)	206 (8.11)	20 (0.79)	10 (0.39)	10 (0.39)	12 kg / 27 lb
PMF-1340	130 (5.12)	400 (15.75)	49 (1.93)	357 (14.06)	20 (0.79)	10 (0.39)	10 (0.39)	20 kg / 44 lb
PMF-1426	140 (5.52)	260 (10.24)	51 (2.01)	216 (8.50)	20 (0.79)	10 (0.39)	10 (0.39)	14 kg / 32 lb
PMF-1515	150 (5.90)	150 (5.91)	51 (2.02)	108 (4.25)	20 (0.79)	10 (0.39)	10 (0.39)	9 kg / 20 lb
PMF-1525	150 (5.91)	250 (9.84)	51 (2.01)	206 (8.11)	20 (0.79)	10 (0.39)	10 (0.39)	15 kg / 33 lb
PMF-1530	150 (5.91)	300 (11.81)	51 (2.01)	257 (10.12)	20 (0.79)	10 (0.39)	10 (0.39)	18 kg / 39 lb
PMF-1535	150 (5.91)	350 (13.78)	51 (2.01)	305 (12.01)	20 (0.79)	10 (0.39)	10 (0.39)	21 kg / 46 lb
PMF-1540	150 (5.91)	400 (15.75)	51 (2.01)	357 (14.06)	20 (0.79)	10 (0.39)	10 (0.39)	24 kg / 53 lb
PMF-1545	150 (5.91)	450 (17.72)	51 (2.01)	407 (17.34)	20 (0.79)	10 (0.39)	10 (0.39)	27 kg / 59 lb
PMF-2030	200 (7.88)	300 (11.81)	51 (2.01)	257 (10.12)	20 (0.79)	10 (0.39)	10 (0.39)	24 kg / 53 lb
PMF-2035	200 (7.88)	350 (13.78)	51 (2.01)	305 (12.01)	20 (0.79)	10 (0.39)	10 (0.39)	28 kg / 61 lb
PMF-2040	200 (7.88)	400 (15.75)	51 (2.01)	357 (14.06)	20 (0.79)	10 (0.39)	10 (0.39)	32 kg / 70 lb
PMF-2045	200 (7.88)	450 (17.72)	51 (2.01)	407 (17.34)	20 (0.79)	10 (0.39)	10 (0.39)	36 kg / 79 lb
PMF-2050	200 (7.88)	500 (19.69)	51 (2.01)	454 (17.87)	20 (0.79)	10 (0.39)	10 (0.39)	40 kg / 88 lb
PMF-2060	200 (7.88)	600 (23.62)	51 (2.01)	556 (21.89)	20 (0.79)	10 (0.39)	10 (0.39)	48 kg / 105 lb
PMF-2063	200 (7.88)	630 (24.80)	51 (2.01)	586 (23.07)	20 (0.79)	10 (0.39)	10 (0.39)	50 kg / 110 lb
PMF-2535	250 (9.85)	350 (13.79)	56 (2.20)	305 (12.01)	22 (0.87)	10 (0.39)	10 (0.39)	38 kg / 84 lb
PMF-2540	250 (9.85)	400 (15.76)	56 (2.20)	357 (14.06)	23 (0.87)	10 (0.39)	10 (0.39)	44 kg / 96 lb
PMF-2550	250 (9.85)	500 (19.70)	56 (2.20)	454 (17.87)	24 (0.87)	10 (0.39)	10 (0.39)	55 kg / 120 lb
PMF-2563	250 (9.85)	630 (24.82)	56 (2.20)	586 (23.07)	25 (0.87)	10 (0.39)	10 (0.39)	69 kg / 151 lb
PMF-3030	300 (11.82)	300 (11.82)	56 (2.20)	257 (10.12)	26 (0.87)	10 (0.39)	10 (0.39)	36 kg / 79 lb
PMF-3040	300 (11.82)	400 (15.76)	56 (2.20)	357 (14.06)	27 (0.87)	10 (0.39)	10 (0.39)	52 kg / 115 lb
PMF-3050	300 (11.82)	500 (19.70)	56 (2.20)	454 (17.87)	28 (0.87)	10 (0.39)	10 (0.39)	66 kg / 144 lb
PMF-3060	300 (11.82)	600 (23.64)	56 (2.20)	556 (21.89)	29 (0.87)	10 (0.39)	10 (0.39)	79 kg / 173 lb
PMF-3063	300 (11.82)	630 (24.82)	56 (2.20)	586 (23.07)	30 (0.87)	10 (0.39)	10 (0.39)	83 kg / 182 lb
PMF-4060	400 (15.76)	600 (23.64)	56 (2.20)	556 (21.89)	31 (0.87)	10 (0.39)	10 (0.39)	106 kg / 233 lb

Unit: mm(in)

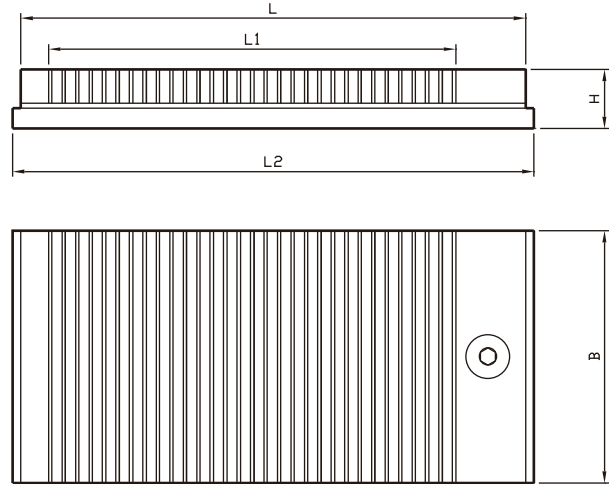

Grinding

● Permanent magnetic low profile chuck

Use:
For spark erosion and precision grinding of small and thin workpieces

- Features:**
- Pole pitch 0.5+1.5 mm
 - Max. magnetic clamping force up to 120 N/cm²
 - Low profile with activation from top surface
 - Suitable for adaption on zero reference system
 - Low flux depth of 6mm and no residual magnetism
 - EDM can be performed close to surface without magnetic interference

Model	Width(B)	Length(L)	Base Length(L2)	Height(H)	L1	Net Weight
PMT-0713	70 (2.76)	130 (5.12)	140 (5.51)	32 (1.26)	67(2.64)	4 kg / 9 lb
PMT-10175	100 (3.94)	175 (6.89)	185 (7.28)	32 (1.26)	117(4.61)	5 kg / 11 lb
PMT-1325	130 (5.12)	250 (9.84)	260 (10.24)	35 (1.38)	192 (7.56)	9 kg / 20 lb
PMT-1515	150 (5.91)	150 (5.91)	160 (6.30)	35 (1.38)	92(3.62)	6 kg / 13 lb
PMT-1525	150 (5.91)	250 (9.84)	260 (10.24)	35 (1.38)	192 (7.56)	10 kg / 22 lb
PMT-1530	150 (5.91)	300 (11.81)	310 (12.20)	35 (1.38)	242 (9.53)	12 kg / 26 lb
PMT-1535	150 (5.91)	350 (13.78)	360 (14.17)	35 (1.38)	292 (11.50)	14 kg / 31 lb
PMT-1545	150 (5.91)	450 (17.72)	460 (18.11)	35 (1.38)	392 (15.43)	18 kg / 40 lb
PMT-2030	200 (7.87)	300 (11.81)	310 (12.20)	35 (1.38)	242 (9.53)	16 kg / 35 lb
PMT-2040	200 (7.87)	400 (15.75)	410 (16.14)	35 (1.38)	342 (13.46)	23 kg / 51lb
PMT-2050	200 (7.87)	500 (19.69)	510 (20.08)	35 (1.38)	442 (17.40)	27 kg / 59 lb
PMT-2535	250 (9.84)	350 (13.78)	360 (14.17)	35 (1.38)	292 (11.50)	24 kg / 53 lb
PMT-3030	300 (11.81)	300 (11.81)	310 (12.20)	35 (1.38)	242 (9.53)	24 kg / 53 lb
PMT-3040	300 (11.81)	400 (15.75)	410 (16.14)	35 (1.38)	342 (13.46)	32 kg / 70 lb

Unit: mm(in)

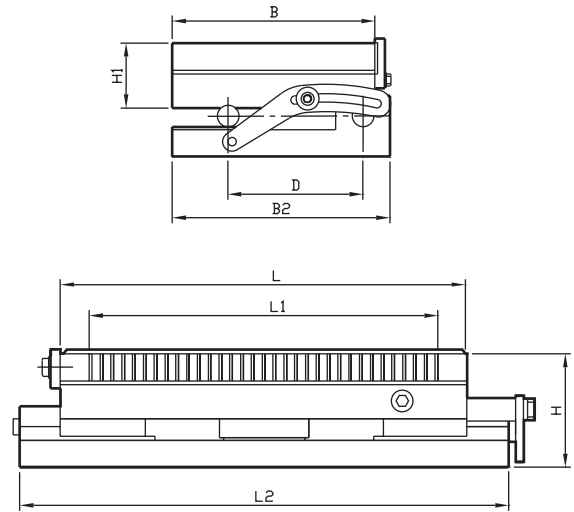

● Precision sine table chuck

Use:

Clamping for grinding, EDM and measuring angle accuracy and quality

Features:

- Pole pitch 0.5+1.5 mm
- Highest clamping force up to 120 N/cm²
- Single piece, hardened (HRC60), precision ground base offering extreme rigidity
- Stable locking of chuck by means of bearing covers and slotted link at the side
- Maximum angular accuracy: ±5"
- Parallelism: ±0.002 mm / 100 mm
- Angle range: 0-45°

Model	Weight (B)	Length (L)	Base Width (B2)	Base Length (L2)	Height (H)	L1	H1	D	Net Weight
PMA-0713	70 (2.76)	130 (5.12)	81 (3.19)	171 (6.73)	84 (3.31)	101 (3.98)	48 (1.89)	50 (1.97)	5 kg / 11 lb
PMA-10175	100 (3.94)	175 (6.89)	115 (4.53)	216 (8.50)	84 (3.31)	140 (5.51)	48 (1.89)	75 (2.95)	10 kg / 22 lb
PMA-1325	130 (5.12)	250 (9.84)	141 (5.55)	311 (12.24)	84 (3.31)	206 (8.11)	48 (1.89)	100 (3.94)	19 kg / 42 lb
PMA-1515	150 (5.91)	150 (5.91)	161 (6.34)	191 (7.52)	84 (3.31)	108 (4.25)	48 (1.89)	125 (4.92)	13 kg / 29 lb
PMA-1525	150 (5.91)	250 (9.84)	161 (6.34)	311 (12.24)	84 (3.31)	206 (8.11)	48 (1.89)	125 (4.92)	22 kg / 48 lb
PMA-1530	150 (5.91)	300 (11.81)	161 (6.34)	361 (14.21)	84 (3.31)	257 (10.12)	48 (1.89)	125 (4.92)	26 kg / 57 lb
PMA-1535	150 (5.91)	350 (13.78)	161 (6.34)	411 (16.18)	84 (3.31)	305 (12.01)	48 (1.89)	125 (4.92)	30 kg / 66 lb
PMA-1540	150 (5.91)	400 (15.75)	161 (6.34)	461 (18.15)	84 (3.31)	357 (14.06)	48 (1.89)	125 (4.92)	35 kg / 77 lb

Unit: mm(in)

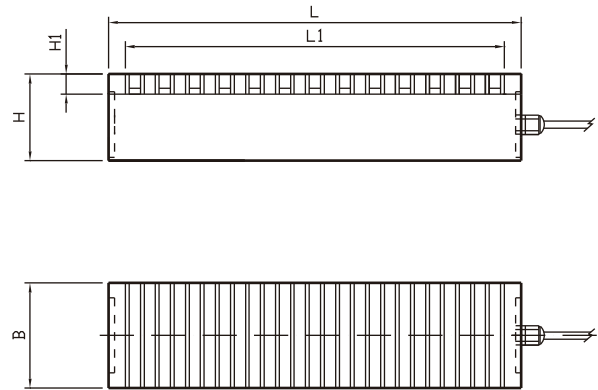

Grinding

● Standard pitch electromagnetic chuck

Use:

Clamping for knife grinding

Features:

- Pole pitch 3+16 mm
- Highest clamping force up to 150 N/cm²
- Solid top plate with high precision
- Real magnetic poles
- Minimum mechanical deformation with solid one-piece housing
- Low current with minimum power consumption

Model	Width (B)	Length (L)	Height (H)	L1	H1	Voltage	Current	Net Weight
EMK-1167	128 (5.04)	665 (26.18)	96 (3.78)	574 (22.60)	21 (083)	90-110V	0.9A	61 kg / 133 lb
EMK-16160	160 (6.30)	1600 (62.99)	150 (5.91)	1542 (60.71)	30 (1.18)	90-110V	1.0A	285 kg / 626 lb
EMK-18160	180 (7.09)	1600 (62.99)	150 (5.91)	1542 (60.71)	30 (1.18)	90-110V	1.1A	320 kg / 704 lb
EMK-20100	200 (7.87)	1000 (39.37)	150 (5.91)	934 (36.77)	30 (1.18)	90-110V	1.1A	223 kg / 491 lb
EMK-20150	200 (7.87)	1500 (59.06)	150 (5.91)	1433 (56.42)	30 (1.18)	90-110V	1.2A	333 kg / 734 lb
EMK-20180	200 (7.87)	1800 (70.87)	150 (5.91)	1732 (68.19)	30 (1.18)	90-110V	1.5A	400 kg / 880 lb

Unit: mm(in)

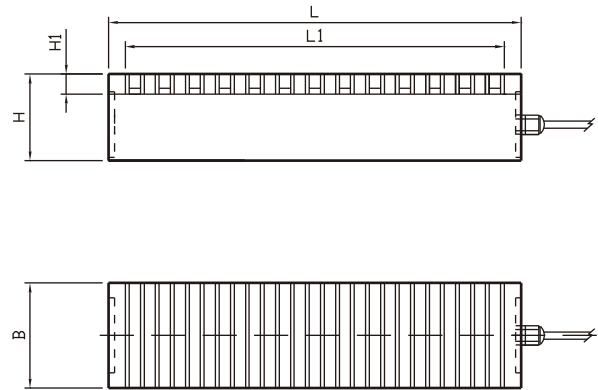

● **Standard pitch electro-permanent magnetic chuck**

Use:

Clamping for knife grinding

Features:

- Pole pitch 3+16 mm
- Highest clamping force up to 150 N/cm²
- Electro-permanent magnetic technology with no deformation owing to the rise of temperature
- Solid top plate with high precision
- Real magnetic poles
- Minimum mechanical deformation with solid one-piece housing

Model	Width (B)	Length (L)	Height (H)	L1	H1	Net Weight	Controller(400V)
EPZ-1167	128 (5.04)	665 (26.18)	96 (3.78)	574 (22.60)	21 (083)	61 kg / 133 lb	CGA
EPZ-16160	160 (6.30)	1600 (62.99)	150 (5.91)	1542 (60.71)	30 (1.18)	285 kg / 626 lb	CGA
EPZ-18160	180 (7.09)	1600 (62.99)	150 (5.91)	1542 (60.71)	30 (1.18)	320 kg / 704 lb	CGA
EPZ-20100	200 (7.87)	1000 (39.37)	150 (5.91)	934 (36.77)	30 (1.18)	223 kg / 491 lb	CGA
EPZ-20150	200 (7.87)	1500 (59.06)	150 (5.91)	1433 (56.42)	30 (1.18)	333 kg / 734 lb	CGA
EPZ-20180	200 (7.87)	1800 (70.87)	150 (5.91)	1732 (68.19)	30 (1.18)	400 kg / 880 lb	CGA

Unit: mm(in)

PPN / PPA



● Pallet chuck

Use:
Clamping for heavy machining for medium to large work pieces

- Features:**
- Square pole size 50x50 mm
 - Magnetic force higher than 350 kg per pole
 - Electro-permanent technology with no deformation owing to the rise of temperature
 - Distortion free clamping with auto-shim pole extensions
 - No residual magnetism
 - Controlled flux prevents magnetization of the tool
 - Workpiece larger than the table size are machinable

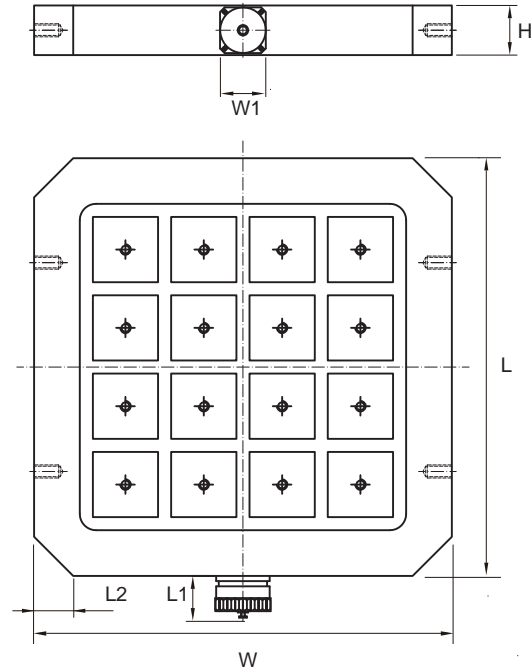

Model	Width	Length	Height	W1	L1	L2	Net Weight
PPN-3232	320 (12.60)	320 (12.60)	38 (1.50)	35 (1.38)	35 (1.38)	30 (1.18) x 45°	30 kg / 66 lb

Unit: mm(in)



● Pallet chuck

Use:
For zero point clamping systems

- Features:**
- Aluminium housing
 - Pole pitch 5+3 mm
 - Two switchable sections
 - Max magnetic clamping force up to 160 N/cm²
 - Low magnetic flux

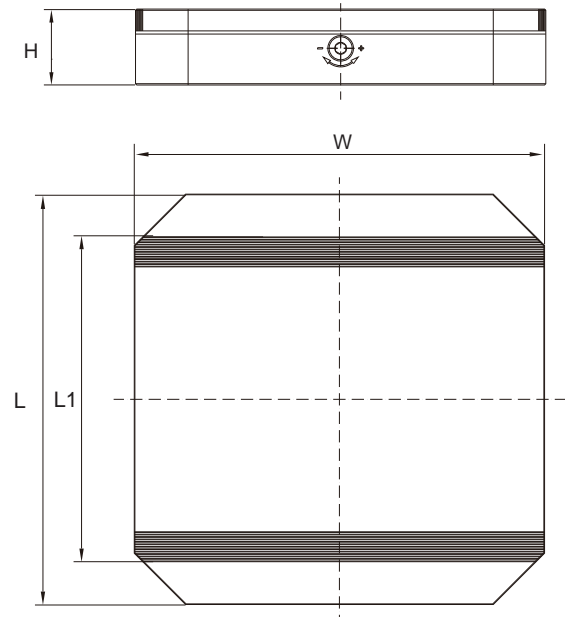

Model	Width	Length	Height	L1	Net Weight
PPA-2424	240 (9.45)	240 (9.45)	60 (2.36)	174 (6.85)	19.5 kg / 43 lb
PPA-2828	280 (11.02)	280 (11.02)	60 (2.36)	214 (8.43)	22 kg / 49 lb
PPA-3232	320 (12.60)	320 (12.60)	60 (2.36)	254 (10)	26 kg / 57 lb

Unit: mm(in)

PPC / PPM

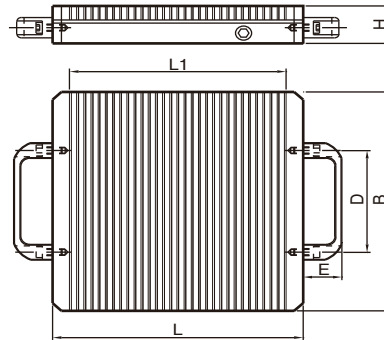

● Pallet chuck

Use:
Clamping for palletizing system

- Features:**
- Pole pitch 0.5+1.5 mm
 - Max magnetic clamping force up to 120 N/cm²
 - No residual magnetism
 - High precision and low flux depth 6 mm
 - Very light switching force
 - High accuracy guaranteed through entire service life



Model	Width	Length	Height	L1	D	E	Net Weight
PPC-2424/40	240 (9.45)	240 (9.45)	40 (1.57)	197 (7.76)	130 (5.12)	40 (1.57)	16 kg / 35 lb
PPC-2828/40	280 (11.02)	280 (11.02)	40 (1.57)	237 (9.33)	130 (5.12)	40 (1.57)	22 kg / 48 lb
PPC-3232/40	320 (12.60)	320 (12.60)	40 (1.57)	279 (10.98)	130 (5.12)	40 (1.57)	28 kg / 62 lb

Unit: mm(in)

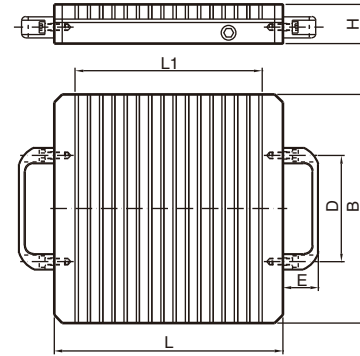

● Pallet chuck

Use:
Clamping for palletizing system

- Features:**
- Pole pitch 4+11 mm
 - Max. Magnetic clamping force up to 180 N/cm²
 - No residual magnetism
 - Strong clamping force with low flux depth 12 mm
 - Easy to activate and de-activate
 - High accuracy guaranteed through entire service life

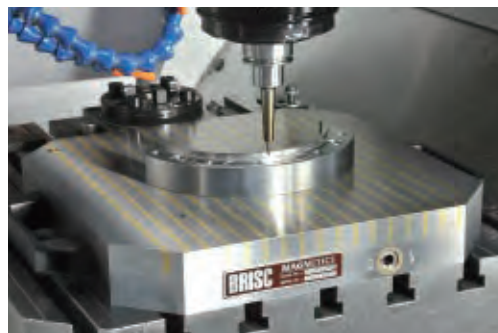

Model	Width	Length	Height	L1	D	E	Net Weight
PPM-2424-48	240 (9.45)	240 (9.45)	48 (1.89)	184 (7.24)	130 (5.12)	40 (1.57)	19 kg / 42 lb
PPM-2828-48	280 (11.02)	280 (11.02)	48 (1.89)	214 (8.43)	130 (5.12)	40 (1.57)	20 kg / 57 lb
PPM-3232-48	320 (12.60)	320 (12.60)	48 (1.89)	259 (10.20)	130 (5.12)	40 (1.57)	35 kg / 77 lb

Unit: mm(in)

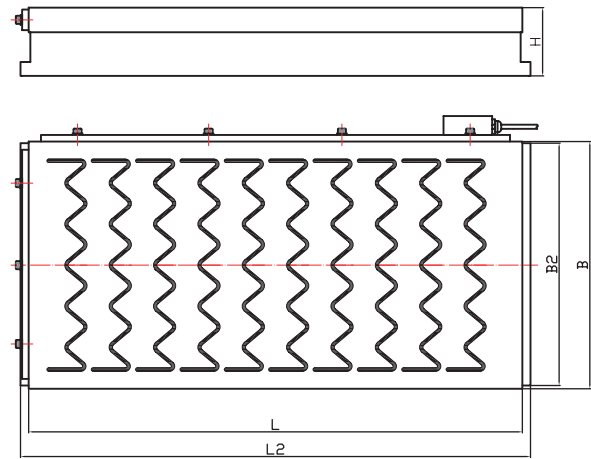
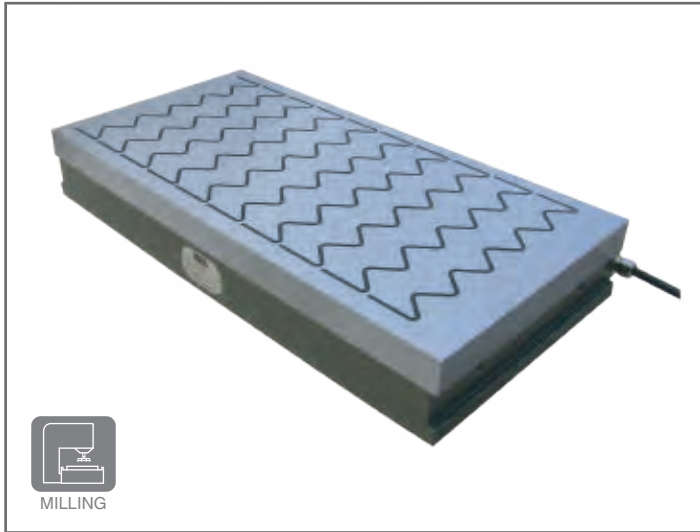

● Powerful electromagnetic chuck

Use:

Clamping for heavy machining operation

Features:

- Highest clamping force up to 180 N/cm²
- Can eliminate residual magnetism
- Coolant and water proof structure
- Solid top plate with high precision and real magnetic poles
- Minimum mechanical deformation with solid one-piece housing
- Low current with minimum power consumption

Model	Width (B)	Length (L)	Height (H)	B2	L2	Voltage	Current	Net Weight
EMI-3060	300 (11.81)	600 (23.62)	85 (3.35)	298 (11.73)	620 (24.41)	110 V	1.5 A	120 kg / 264 lb
EMI-3090	300 (11.81)	900 (35.43)	85 (3.35)	298 (11.73)	920 (36.22)	110 V	2.1 A	180 kg / 396 lb
EMI-4080	400 (15.75)	800 (31.50)	85 (3.35)	398 (15.67)	820 (32.28)	110 V	2.5 A	213 kg / 469 lb
EMI-40100	400 (15.75)	1000 (39.37)	85 (3.35)	398 (15.67)	1020 (40.16)	110 V	3.1 A	266 kg / 585 lb
EMI-50100	500 (19.69)	1000 (39.37)	85 (3.35)	498 (19.61)	1020 (40.16)	110 V	3.9 A	333 kg / 733 lb
EMI-50150	500 (19.69)	1500 (59.06)	85 (3.35)	498 (19.61)	1520 (59.84)	110 V	5.8 A	500 kg / 1100 lb
EMI-60100	600 (23.62)	1000 (39.37)	85 (3.35)	598 (23.54)	1020 (40.16)	110 V	4.7 A	400 kg / 800 lb
EMI-60150	600 (23.62)	1500 (59.06)	85 (3.35)	598 (23.54)	1520 (59.84)	110 V	7.0 A	600 kg / 1320 lb
EMI-70150	700 (27.56)	1500 (59.06)	85 (3.35)	698 (27.48)	1520 (59.84)	110 V	7.7 A	700 kg / 1540 lb

Unit: mm(in)



● Square pole electro-permanent magnetic chuck with standard density

Use:

Clamping for heavy machining for medium to large work pieces

Features:

- Square pole size 50x50 mm
- Magnetic force higher than 350 kg per pole
- Electro-permanent technology with no deformation owing to the rise of temperature
- Distortion free clamping with auto-shim pole extensions
- No residual magnetism
- Controlled flux prevents magnetization of the tool
- Flux depth 12 mm
- Workpiece larger than the table size are machinable
- Multiple magnet combinations can provide clamping for any table size, large or small

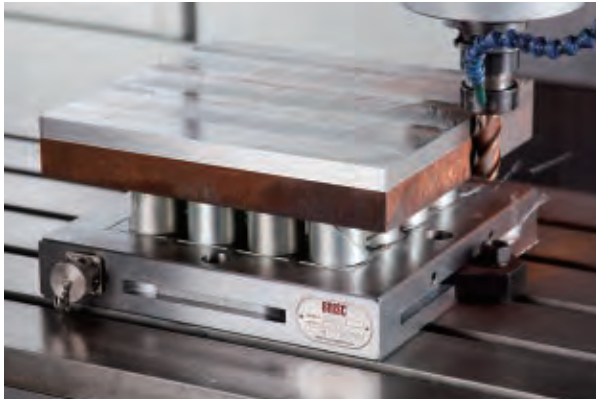

Model	Width	Length	Height	Pole No.	Net Weight	Controller (220V)	Controller (220/480V)	Controller (400/480V)
PSP-3634	360 (14.17)	340 (13.39)	59 (2.32)	20	56 kg / 123 lb	CUA	CUA-CP	CUA
PSP-3649	360 (14.17)	490 (19.29)	59 (2.32)	30	82 kg / 180 lb	CUA	CUA-CP	CUA
PSP-3664	360 (14.17)	640 (25.20)	59 (2.32)	40	107 kg / 235 lb	CUA	CUA-CP	CUA
PSP-3679	360 (14.17)	790 (31.10)	59 (2.32)	50	133 kg / 293 lb	CUA	CUD-CP	CUA
PSP-4264	420 (16.54)	640 (25.20)	59 (2.32)	48	126 kg / 277 lb	CUA	CUD-CP	CUA
PSP-4279	420 (16.54)	790 (31.10)	59 (2.32)	60	156 kg / 343 lb	CUD	CUD-CP	CUA
PSP-4294	420 (16.54)	940 (37.01)	59 (2.32)	72	186 kg / 410 lb	CUD	CUD-CP	CUA
PSP-42109	420 (16.54)	1090 (42.91)	59 (2.32)	84	215 kg / 473 lb	CUD		CUA
PSP-4864	480 (18.90)	640 (25.20)	59 (2.32)	56	144 kg / 317 lb	CUA	CUD-CP	CUA
PSP-4879	480 (18.90)	790 (31.10)	59 (2.32)	70	178 kg / 392 lb	CUD	CUD-CP	CUA
PSP-4894	480 (18.90)	940 (37.01)	59 (2.32)	84	212 kg / 467 lb	CUD		CUA
PSP-48109	480 (18.90)	1090 (42.91)	59 (2.32)	98	246 kg / 542 lb	CUD		CUD
PSP-6064	600 (23.62)	640 (25.20)	59 (2.32)	72	180 kg / 396 lb	CUD	CUD-CP	CUA
PSP-6079	600 (23.62)	790 (31.10)	59 (2.32)	90	223 kg / 491 lb	CUD		CUD
PSP-6094	600 (23.62)	940 (37.01)	59 (2.32)	108	265 kg / 584 lb	CUD		CUD
PSP-60109	600 (23.62)	1090 (42.91)	59 (2.32)	126	308 kg / 679 lb			CUD

Unit: mm(in)

Pole Extension

• Fix pole extensions

• Auto-shim pole extensions

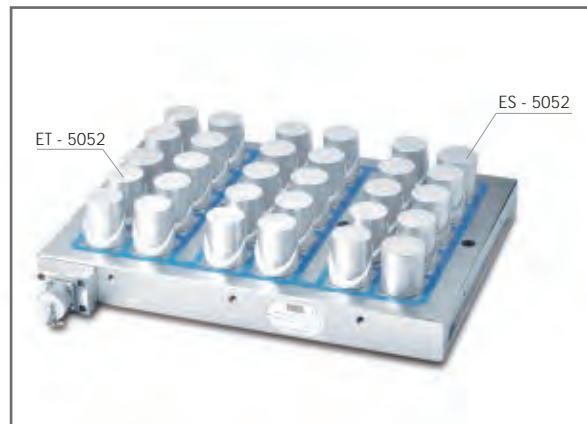
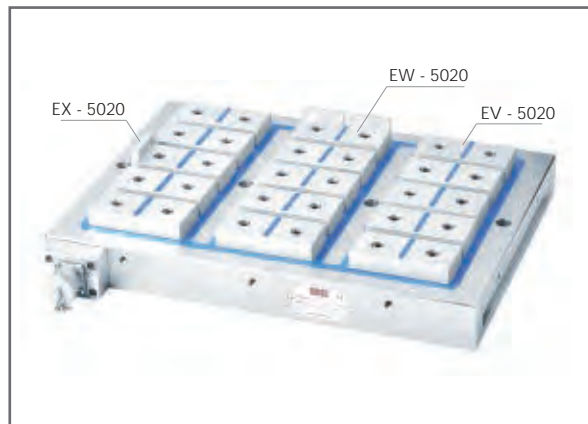

EV-5020
50x50 mm fix pole extension with height 20 mm



EW-5020
50x50 mm fix pole extension with height 20 mm and step



EX-5020
50x50 mm fix pole extension with height 20 mm and step



ES-5052
Diameter 50 mm auto-shim pole extension with height 52 mm



ET-5052
Diameter 50 mm auto-shim pole extension with height 52 mm



EE-5020
50x50 mm fix pole extension with height 20 mm and step



EA-5020
50x50 mm fix pole extension with height 20 mm



EA-5050
50x50 mm fix pole extension with height 50 mm



EC-5050
50x50 mm auto-shim pole extension with height 50 mm



ES-5052

Fix pole extensions

ES fixed and ET self shimming pole extensions using the built in threaded rod which does not require tools to install or remove.

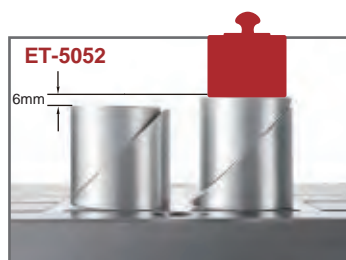

ET-5052

Mobile pole extensions

The new and improved ET pole extension has increased the performance of the original ET by 20%. Total adjustment is 6 mm.

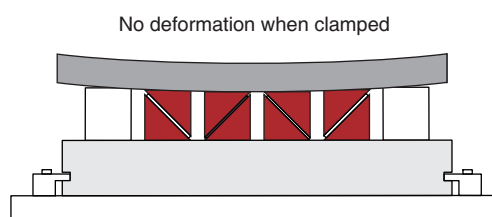
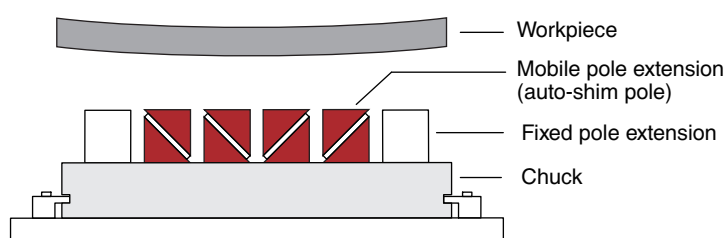



● **Square pole electro-permanent magnetic chuck with standard density**

Use:

Clamping for heavy machining for medium to large work pieces

Features:

- Square pole size 50x50 mm
- Magnetic force higher than 350 kg per pole
- Electro-permanent technology with no deformation owing to the rise of temperature
- Distortion free clamping with auto-shim pole extensions
- No residual magnetism
- Controlled flux prevents magnetization of the tool
- Flux depth 12 mm
- Workpiece larger than the table size are machinable

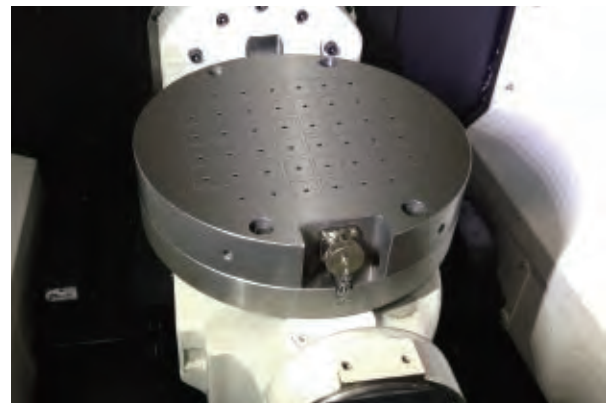

Model	Diameter	Height	Pole No.	Net Weight	Controller (220V)	Controller (400/480V)
PRP-400	400 (15.75)	45 (1.77)	21	42 kg / 92.6 lb	CUA	CUA
PRP-500	500 (19.69)	45 (1.77)	32	66 kg / 145.5 lb	CUA	CUA
PRP-600	600 (23.62)	45 (1.77)	52	95 kg / 209.4 lb	CUA	CUA
PRP-700	700 (27.56)	45 (1.77)	68	130 kg / 286.6 lb	CUD	CUA
PRP-800	800 (31.50)	45 (1.77)	96	170 kg / 374.8 lb	CUD	CUD
PRP-900	900 (35.43)	45 (1.77)	120	214 kg / 471.7 lb	CUF	CUD
PRP-1000	1000 (39.37)	45 (1.77)	156	265 kg / 584.2 lb	CUF	CUD

Unit: mm(in)

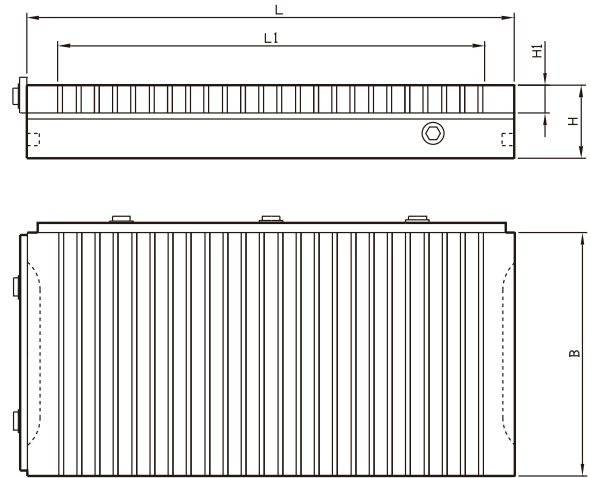

Milling

● Permanent magnetic chuck for milling

Use:

Clamping for heavy machining operation

Features:

- Pole pitch 4+11 mm
- Max. magnetic clamping force up to 180 N/cm²
- Highly concentrated magnetic field with low flux depth 6 mm
- Low flux depth prevents magnetization of the tooling
- Coolant and water proof structure
- Easy to activate and de-activate
- High precision with no residual magnetism



Model	Width	Length	Effective Length	Height	H1	Net Weight
PMM-1525	150 (5.91)	250 (9.84)	199 (7.83)	60 (2.36)	23 (0.91)	17 kg / 37 lb
PMM-1530	150 (5.91)	300 (11.81)	259 (10.20)	60 (2.36)	23 (0.91)	20 kg / 44 lb
PMM-1535	150 (5.91)	350 (13.78)	304 (11.97)	60 (2.36)	23 (0.91)	24 kg / 53 lb
PMM-1545	150 (5.91)	450 (17.72)	409 (16.10)	60 (2.36)	23 (0.91)	31 kg / 68 lb
PMM-2030	200 (7.87)	300 (11.81)	259 (10.20)	60 (2.36)	23 (0.91)	29 kg / 64 lb
PMM-2040	200 (7.87)	400 (15.75)	349 (13.74)	60 (2.36)	23 (0.91)	37 kg / 81 lb
PMM-2045	200 (7.87)	450 (17.72)	409 (16.10)	60 (2.36)	23 (0.91)	41 kg / 90 lb
PMM-2050	200 (7.87)	500 (19.69)	454 (17.84)	60 (2.36)	23 (0.91)	46 kg / 101 lb
PMM-2060	200 (7.87)	600 (23.62)	559 (22.01)	60 (2.36)	23 (0.91)	55 kg / 121 lb
PMM-2530	250 (9.84)	300 (11.81)	259 (10.20)	60 (2.36)	23 (0.91)	35 kg / 77 lb
PMM-2535	250 (9.84)	350 (13.78)	304 (11.97)	60 (2.36)	23 (0.91)	41 kg / 90 lb
PMM-2540	250 (9.84)	400 (15.75)	349 (13.74)	60 (2.36)	23 (0.91)	47 kg / 103 lb
PMM-2545	250 (9.84)	450 (17.72)	409 (16.10)	60 (2.36)	23 (0.91)	52 kg / 342 lb
PMM-3030	300 (11.81)	300 (11.81)	259 (10.20)	60 (2.36)	23 (0.91)	39 kg / 86 lb
PMM-3040	300 (11.81)	400 (15.75)	349 (13.74)	60 (2.36)	23 (0.91)	52 kg / 114 lb
PMM-3050	300 (11.81)	500 (19.69)	459 (18.07)	60 (2.36)	23 (0.91)	65 kg / 143 lb
PMM-3060	300 (11.81)	600 (23.62)	559 (22.01)	60 (2.36)	23 (0.91)	80 kg / 176 lb
PMM-4040	400 (15.75)	400 (15.75)	349 (13.74)	60 (2.36)	23 (0.91)	71 kg / 156 lb

Unit: mm(in)

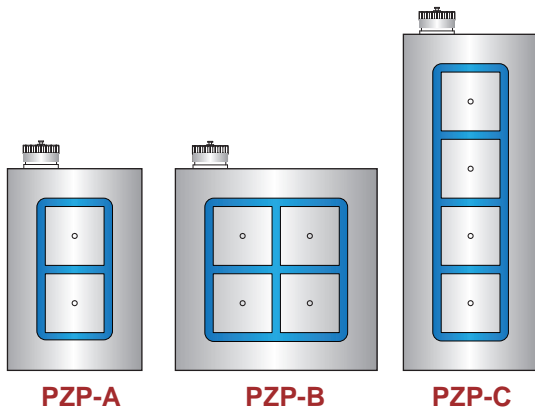

● Electro-permanent magnetic module with double sided clamping surfaces

Use:
Clamping for heavy machining for medium to large work pieces

- Features:**
- With double sided clamping surfaces
 - Can be self-clamped on the machine table
 - Top surface clamping and bottom surface clamping can be controlled by different channels
 - Channel 1 for top surface clamping, Channel 2 for bottom surface clamping
 - Square pole size 70x70 mm
 - Magnetic force higher than 690 kg per pole
 - With no deformation owing to the rise of the temperature
 - No residual magnetism
 - Workpiece larger than the table size are machinable
 - Multiple magnet combinations can provide clamping for any table size

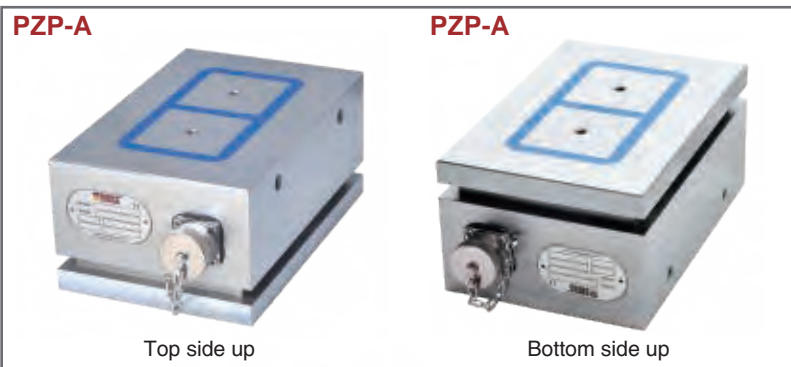

CUT-A with channel selection function
Channel 1 for top, Channel 2 for bottom



Application 1

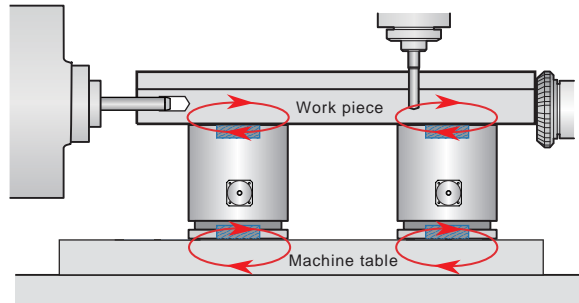

Application 2

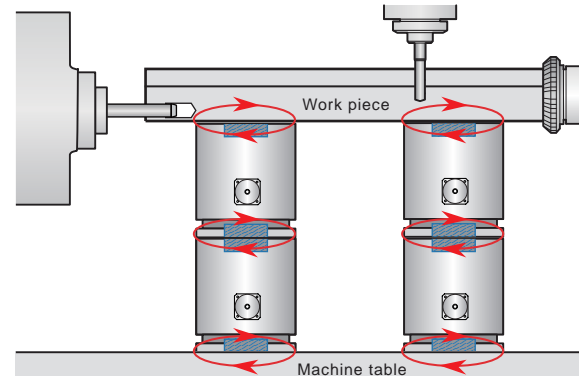

Model	Width	Length	Height	Pole No.	Net Weight	Control Unit (220 / 400V)	Clamping Force per side
PZP-A	160 (6.29)	240 (9.44)	110 (4.33)	2 x 2	33 kg / 62 lb	CUT-A	13.8 kN
PZP-B	240 (9.44)	240 (9.44)	110 (4.33)	4 x 2	49 kg / 62 lb	CUT-A	27.6 kN
PZP-C	160 (6.29)	400 (15.74)	110 (4.33)	4 x 2	59 kg / 62 lb	CUT-A	27.6 kN

Unit: mm(in)

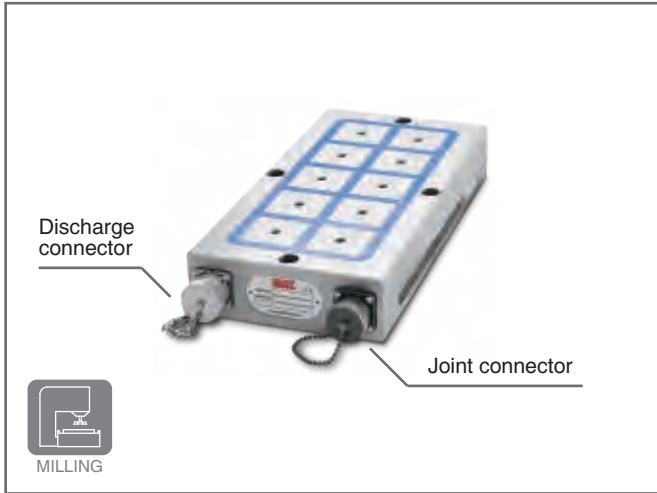

● Electro-permanent magnetic chuck

Use:
Clamping for heavy machining for medium to large work pieces

- Features:**
- Square pole size 50x50 mm
 - Magnetic force higher than 350 kg per pole
 - Electro-permanent technology with no deformation owing to the rise of the temperature
 - Distortion free clamping with auto-shim pole extensions
 - No residual magnetism
 - Controlled flux prevents magnetization of the tool
 - Workpiece larger than the table size are machinable
 - Multiple magnet combinations can provide clamping for any table size, large or small
 - Length of connection cable can be made to order

Milling

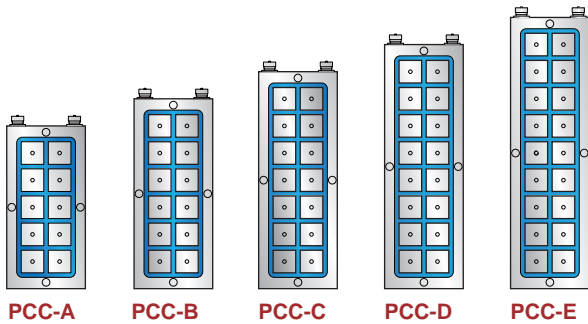

Model	Width	Length	Heigh	Pole No.	Max Plate No.	Net Weight	Control Unit	Clamping Force
PCC-A	174 (6.85)	360 (14.17)	59 (2.32)	10	6	24 kg / 53 lb	CUA	35 kN
PCC-B	174 (6.85)	420 (16.54)	59 (2.32)	12	6	33 kg / 73 lb	CUA	42 kN
PCC-C	174 (6.85)	480 (18.90)	59 (2.32)	14	5	38 kg / 84 lb	CUA	49 kN
PCC-D	174 (6.85)	540 (21.26)	59 (2.32)	16	5	43 kg / 95 lb	CUA	56 kN
PCC-E	174 (6.85)	600 (23.62)	59 (2.32)	18	4	48 kg / 106 lb	CUA	63 kN

Unit: mm(in)

Application A

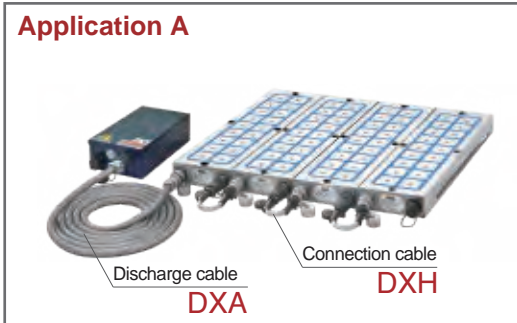

- Can be used next to each other

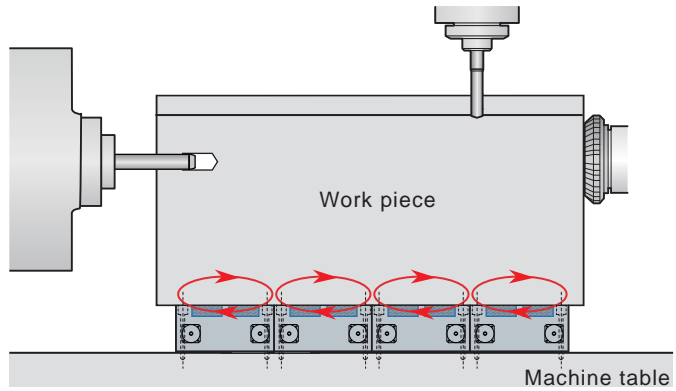

Application B



- Can be used with space in between

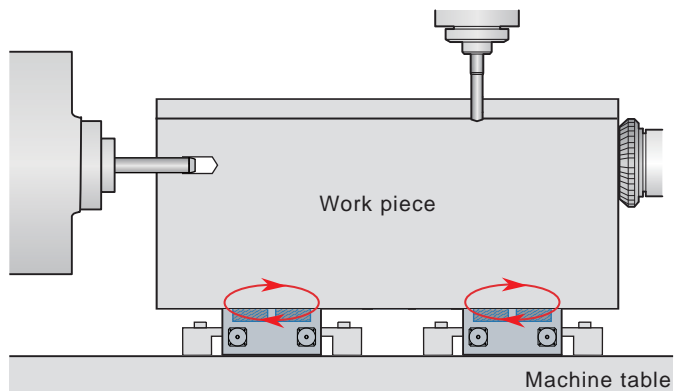

Application C

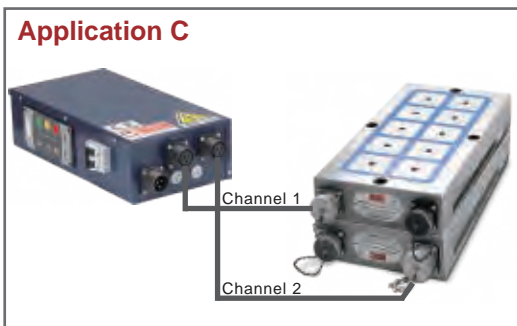

- Can bolt-together two PCC and make it two clamping surface separately

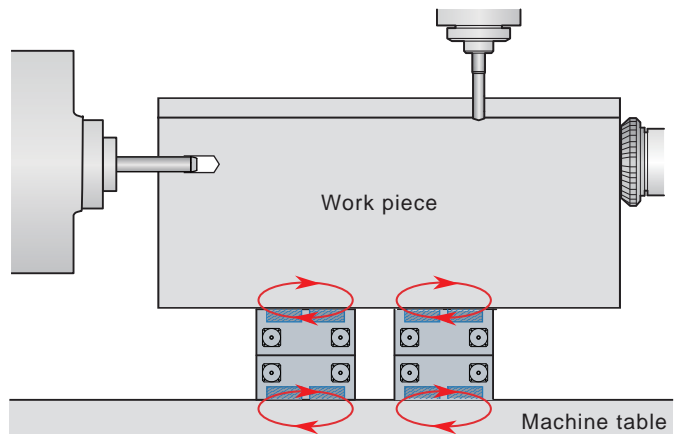

Extension cable

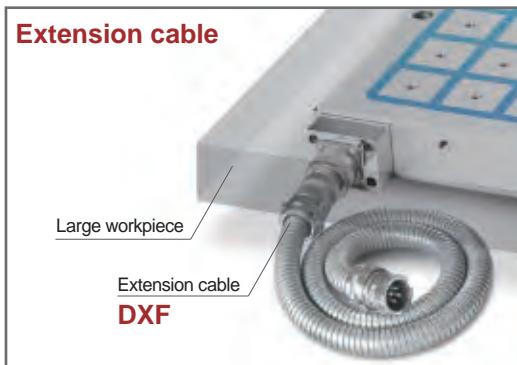

Model	Cable length	Space between chucks	Description
DXH-300	300 (11.8)	0 - 50 (0 - 1.96)	connection cable
DXH-1000	1000 (39.4)	0 - 600 (0 - 23.62)	connection cable

Unit: mm(in)

Model	Cable length	Description
DXF-1000	1000 (39.4)	extension cable
DXF-3000	3000 (118.1)	extension cable
DXA-5	5000 (196.9)	discharge cable
DXA-10	10000 (393.7)	discharge cable

Unit: mm(in)

Different length cable is available upon request.

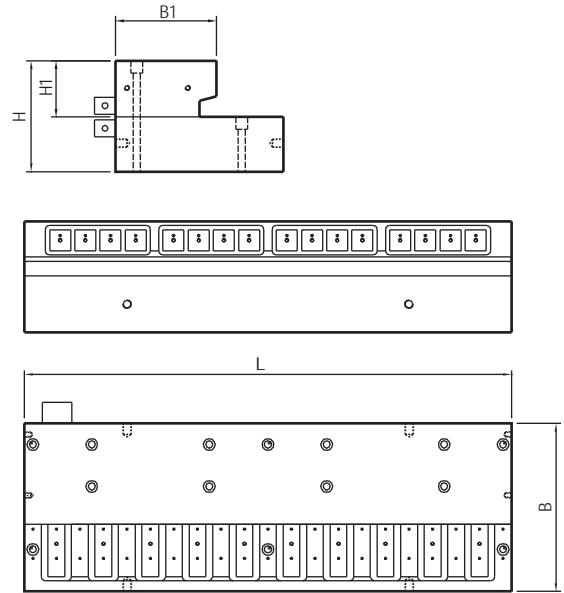

Milling

● Rail milling magnetic clamping system

Use:

Clamping for machining on rail crossings and switches

Features:

- Highest clamping force up to 18t/m
- No electricity needed for the system when machining
- Strong and uniform clamping, no vibrations when machining
- Quick clamping with high efficiency
- Complete machining in one set up
- Without stray magnetic fields and no magnetization of the tool
- Modules can be used jointly

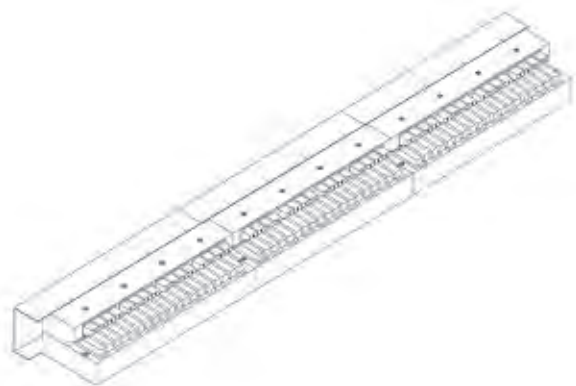

Model	Width(B)	Length(L)	Height(H)	H1	B1	Net Weight
EPK04011	400 (15.75)	1160 (45.67)	268 (10.55)	134 (5.28)	240 (9.45)	734 kg / 1616 lb

Unit: mm(in)

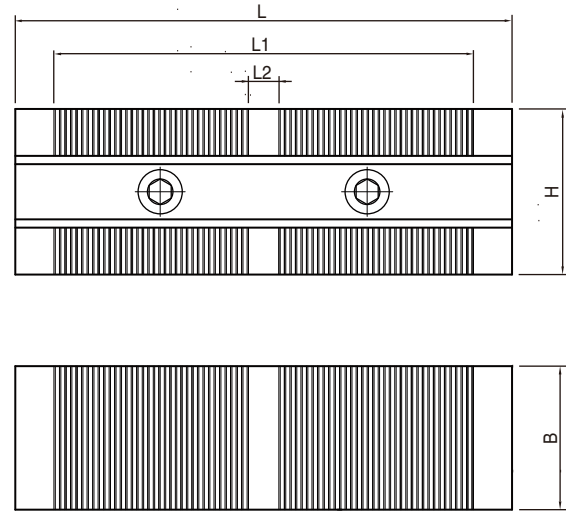

• Permanent magnetic chuck

Use:

Clamping device for holding workpieces securely on spark erosion machines (EDM) or other machining applications, or as part of a fixture.

Features:

- Two clamping surfaces on opposite and individually switchable
- PFD with pole pitch 0.5+1.5 mm
- Max. magnetic uniform clamping force up to 120 N/cm²
- Easy to activate and de-activate
- Coolant and water proof structure
- High precision and no residual magnetism
- Can be supplied in pairs

Model	Width(B)	Length(L)	Height(H)	L1	L2	P	Net Weight
PFD-0513	52 (2.05)	125 (4.92)	60 (2.36)	99 (3.90)	-	1.5+0.5	3.0 kg / 6.6 lb
PFD-0518	52 (2.05)	180 (7.09)	60 (2.36)	152.5 (6.00)	11 (0.43)	1.5+0.5	4.2 kg / 9.3 lb
PFD-0525	52 (2.05)	250 (9.84)	60 (2.36)	224.5 (8.84)	11 (0.43)	1.5+0.5	5.8 kg / 12.8 lb

Unit: mm(in)

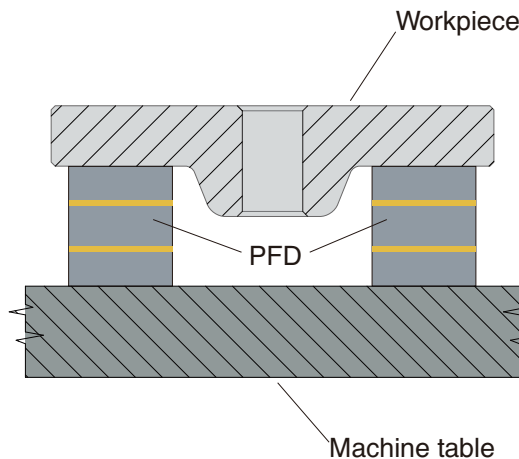

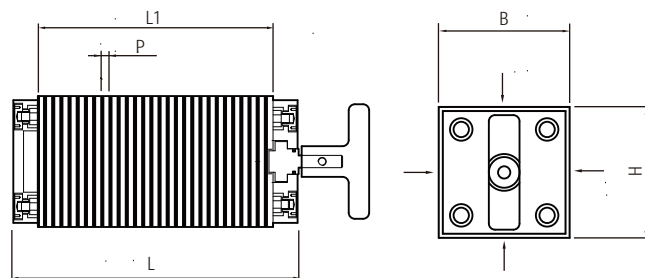

EDM

● Permanent magnetic chuck

Use:
Angular and parallel EDM of small and medium-sized workpieces

- Features:**
- Robust construction with good holding force
 - Pole pitch 2 mm bass / 2 mm steel
 - Nominal holding force standard: 50 N/cm²
 - Nominal holding force stainless 30 N/cm²
 - Magnetic field height : 2 mm
 - Polar plate re-grind of 4 mm
 - Stainless, chrome steel polar plates available for use in wire EDM



Model	Width(B)	Length(L)	Height(H)	L1	P	Net Weight
MBF-140	64 (2.52)	140 (5.51)	64 (2.52)	115 (4.53)	2+2	3.0 kg / 6.6 lb
MBF-160	64 (2.52)	160 (6.30)	64 (2.52)	135 (5.31)	2+2	4.0 kg / 8.8 lb

Unit: mm(in)

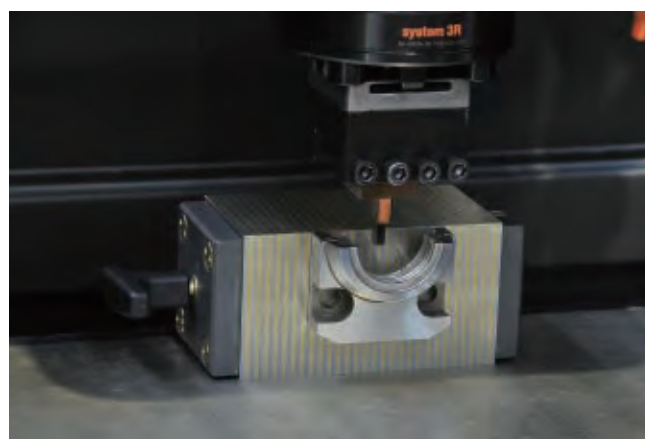
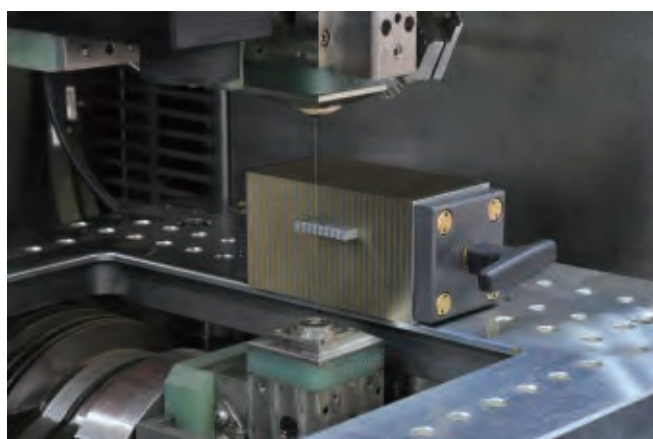

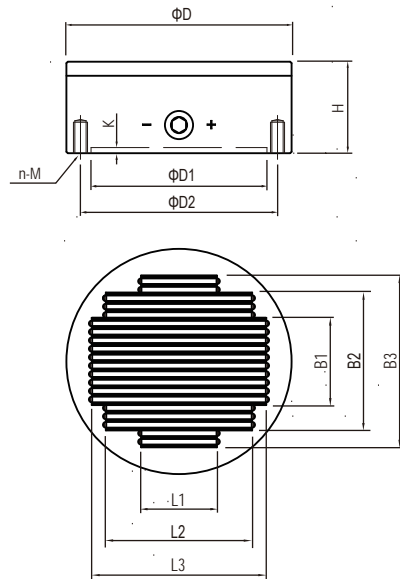

● Permanent magnetic chuck

Use:

For hard to hold parts requiring exceptionally high power, such as high alloyed tool steels and materials containing cobalt.

Features:

- Aluminium housing, pole plate made from tool steel. Extremely high clamping force through neodymium-iron-boron magnets
- Available with flange on request
- NF with pole pitch 2 + 4 mm
- Max. uniform magnetic clamping force up to 180N/cm²
- Best for small and thin workpiece
- Magnetic field height : 4 mm
- Polar plate re-grind of 3mm
- High precision with no residual magnetism

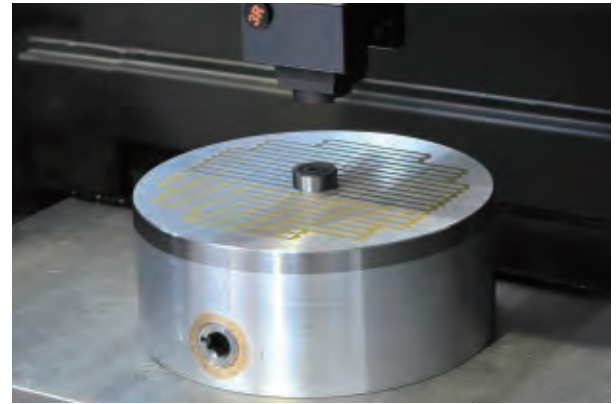

Model	Dia(D)	Height(H)	L1	L2	L3	B1	B2	D1	D2	n	M	K	Net Weight
NF-100	100 (3.94)	65 (2.56)	48 (1.89)	-	-	74 (2.91)	-	70 (2.76)	90 (3.54)	4	6	4	2.2 kg / 4.8 lb
NF-125	125 (4.92)	65 (2.56)	54 (2.13)	88 (3.46)	-	67 (2.64)	98 (3.86)	95 (3.74)	110 (4.33)	5	8	4	3.4 kg / 7.5 lb
NF-160	160 (6.30)	65 (2.56)	54 (2.13)	104 (4.09)	124 (4.88)	62 (2.44)	98 (3.86)	125 (4.92)	140 (5.51)	6	10	4	5.6 kg / 12.3 lb
NF-180	180 (7.09)	65 (2.56)	64 (2.59)	104 (4.09)	124 (4.88)	62 (2.44)	98 (3.86)	125 (4.92)	160 (6.30)	7	10	4	7.1 kg / 15.6 lb
NF-200	200 (7.87)	65 (2.56)	74 (2.91)	104 (4.09)	134 (5.28)	73 (2.87)	110 (4.33)	125 (4.92)	180 (5.51)	8	10	4	8.7 kg / 19.2 lb

Unit: mm(in)

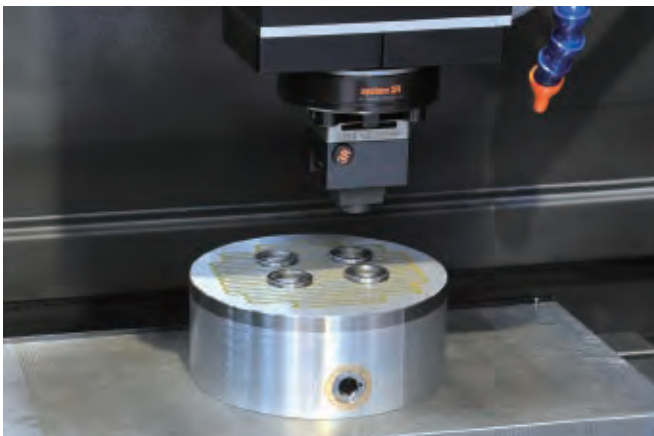

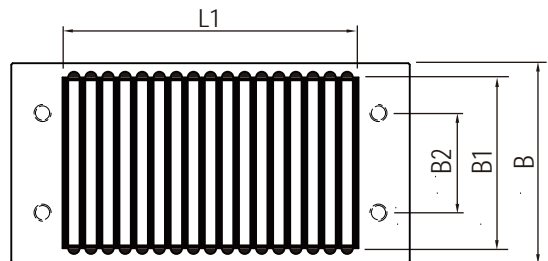
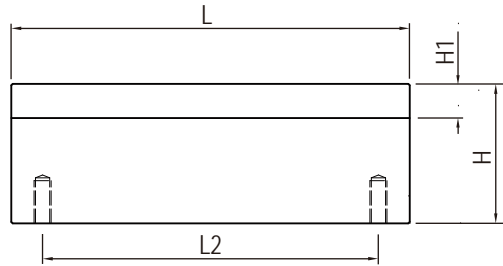

• Permanent magnetic chuck

Use:

For complex, small, hard to hold parts requiring extra accuracy and power

Features:

- PMB with pole pitch 2 + 4 mm
- High polar plate stability of ± 0.002 mm
- Bigger sizes available on request
- Highest uniform clamping force up to 180 N/cm²
- Magnetic field height : 10 mm
- Polar plate re-grind of 3 mm
- Clamping of more than one workpiece is possible

Model	Width(B)	Length(L)	L1	L2	Height(H)	H1	B1	B2	Net Weight
PMB-714	70 (2.76)	140 (5.51)	118 (4.65)	100 (3.94)	49 (1.93)	12 (0.47)	60 (2.36)	35 (1.38)	3.5 kg / 7.7lb
PMB-720	70 (2.76)	200 (7.87)	170 (7.00)	150 (5.91)	49 (1.93)	12 (0.47)	60 (2.36)	35 (1.38)	5 kg / 11lb

Unit: mm(in)

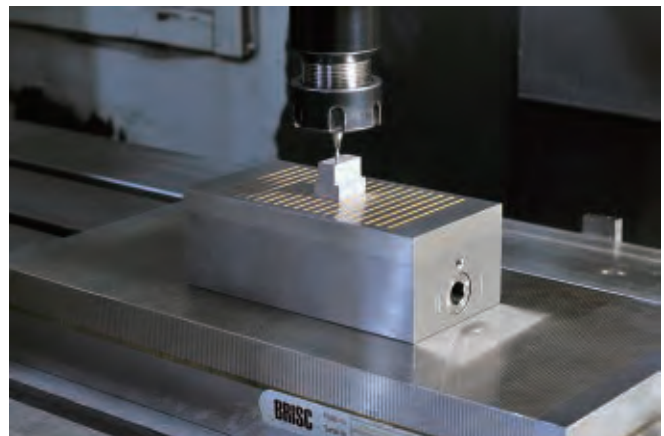

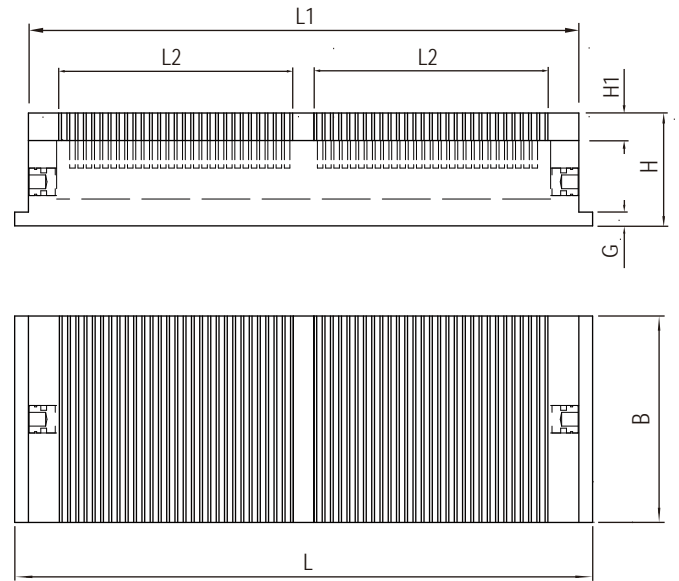
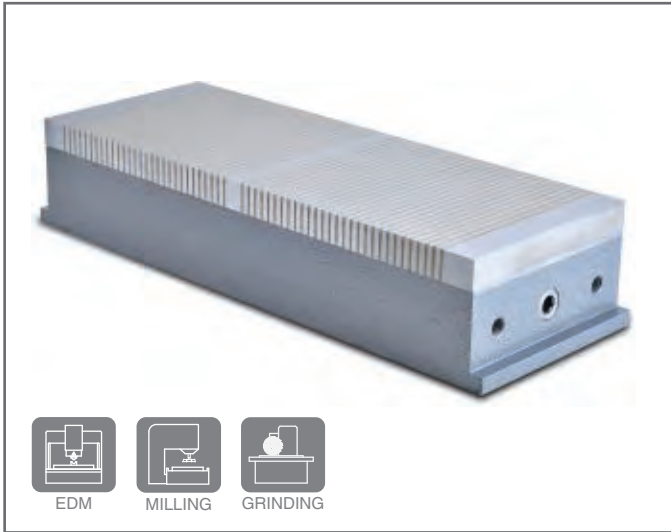

● Permanent magnetic chuck

Use:

For hard to clamp parts requiring exceptionally high power, such as high alloyed tool steels and materials containing cobalt

Features:

- Extremely high clamping force due to a specially developed construction, stable all-steel body
- ON-OFF control on both ends
- Larger models with power-operated switching mechanism available on request
- Pole pitch 4 mm ST and 2 mm with extra NdFeB between the poles
- Max. uniform magnetic clamping force up to 180 N/cm²
- Magnetic field height : 10 mm
- Polar plate re-grind of 3 mm

Model	Width(B)	Length(L)	Height(H)	L1	L2	H1	G	Net Weight
PMG-1540	150 (5.91)	420 (16.54)	82 (3.23)	400 (15.75)	170 (6.69)	20 (0.79)	10 (0.39)	33 kg / 73 lb

Unit: mm(in)

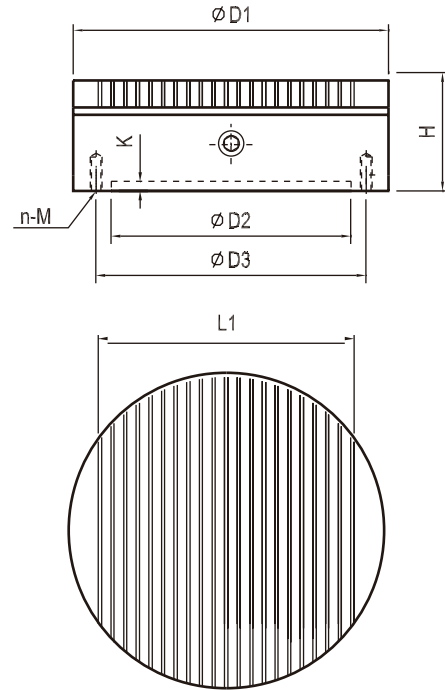

● Circular permanent magnetic chuck with micropitch poles

Use:

Clamping for grinding

Features:

- PMY with pole pitch 0.5+1.5 mm
- Max. uniform magnetic clamping force up to 120 N/cm²
- Best for small and thin workpiece
- Low height and light weight
- High precision with no residual magnetism

Model	Diameter(D)	Height	L1	D2	D3	n	M	K	Net Weight
PMY-100	100 (3.94)	50 (1.97)	76.5 (3.01)	60 (2.36)	85 (3.35)	4	8	4 (0.16)	3 kg / 7 lb
PMY-130	130 (5.12)	50 (1.97)	100 (3.94)	90 (3.54)	115 (4.53)	4	8	4 (0.16)	5 kg / 11 lb
PMY-150	150 (5.91)	50 (1.97)	117 (4.61)	110 (4.33)	132 (5.20)	4	8	4 (0.16)	7 kg / 15 lb
PMY-160	160 (6.30)	52 (2.05)	129 (5.08)	120 (4.72)	140 (5.51)	4	10	4 (0.16)	8 kg / 18 lb
PMY-200	200 (7.87)	52 (2.05)	169 (6.65)	160 (6.30)	180 (7.09)	4	10	4 (0.16)	12 kg / 26 lb
PMY-250	250 (9.84)	52 (2.05)	213 (8.39)	200 (7.87)	230 (9.06)	4	10	4 (0.16)	19 kg / 42 lb
PMY-300	300 (11.81)	54 (2.13)	265 (10.43)	250 (9.84)	280 (11.02)	4	12	4 (0.16)	28 kg / 62 lb
PMY-400	400 (15.75)	58 (2.28)	360 (14.17)	320 (12.60)	360 (14.17)	6	12	4 (0.16)	57 kg / 125 lb
PMY-600	600 (23.62)	62 (2.44)	553 (21.77)	500 (19.69)	540 (21.26)	6	12	5 (0.20)	137 kg / 301 lb

Unit: mm(in)

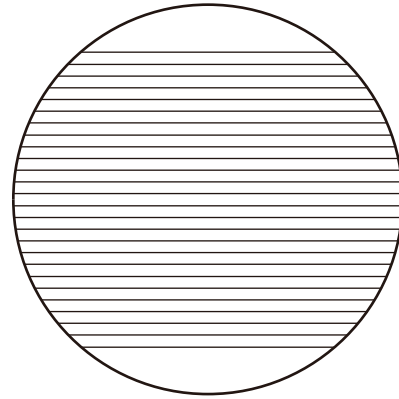
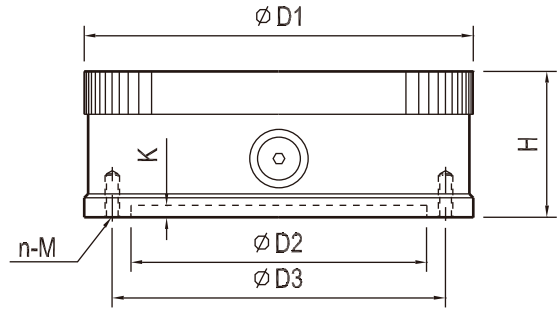

● **Circular permanent magnetic chuck with parallel poles**

Use:

Clamping for grinding and turning

Features:

- Pole pitch 5+8 mm
- Max. magnetic clamping force up to 140 N/cm²
- Concentric grooves simplify the centring of workpiece
- Variable magnetic clamping force
- Balanced for high RPM
- Centre drilling of locating hole is available on request
- High precision with no residual magnetism

Model	Diameter(D1)	Height(H)	D2	D3	n	M	K	Net Weight
NY-100	100 (3.94)	60 (2.36)	70 (2.76)	85 (3.35)	4	8	5 (0.2)	3.5 kg / 7.7 lb
NY-130	130 (5.12)	60 (2.36)	90 (3.54)	100 (3.94)	4	8	5 (0.2)	5.9 kg / 13 lb
NY-150	150 (5.91)	60 (2.36)	110 (4.33)	115 (4.53)	4	8	5 (0.2)	8 kg / 224 lb
NY-160	160 (6.30)	60 (2.36)	120 (4.72)	140 (5.51)	4	8	5 (0.2)	9 kg / 19.8 lb
NY-200	200 (7.87)	80 (3.15)	150 (6.30)	180 (7.09)	6	8	5 (0.2)	13 kg / 29 lb
NY-250	250 (9.84)	80 (3.15)	200 (7.87)	230 (9.06)	6	8	5 (0.2)	20 kg / 44 lb
NY-300	300 (11.81)	85 (3.35)	250 (9.84)	280 (11.02)	6	8	5 (0.2)	29 kg / 64 lb
NY-350	350 (13.78)	85 (3.35)	300 (11.81)	330 (12.99)	6	12	5 (0.2)	40 kg / 88 lb
NY-400	400 (15.75)	85 (3.35)	300 (11.81)	350 (47.24)	6	12	5 (0.2)	59 kg / 130 lb
NY-450	450 (17.72)	85 (3.35)	350 (13.78)	400 (59.06)	6	12	5 (0.2)	70 kg / 154 lb
NY-500	500 (19.69)	85 (3.35)	400 (15.75)	450 (17.72)	6	12	5 (0.2)	90 kg / 198 lb

Unit: mm(in)

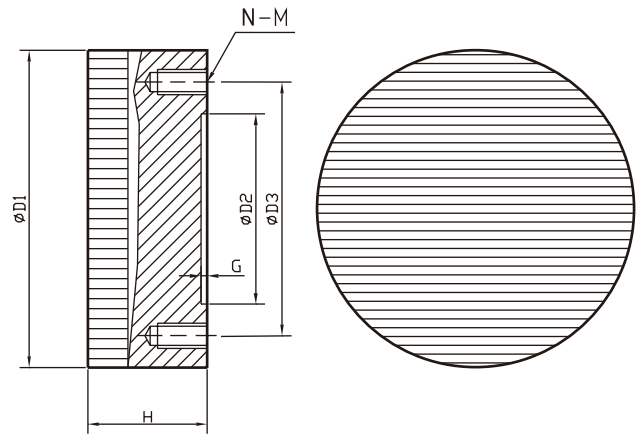

Turning

● **Circular electro-permanent magnetic**

Use:
Clamping for grinding of disc shaped workpieces on internal and external grinders with rotary tables

- Features:**
- Pole pitch 1+3 mm
 - Max. magnetic clamping force up to 120 N/cm²
 - Electro-permanent technology with no deformation owing to the rise of temperature
 - Can eliminate residual magnetism from the workpiece
 - Coolant and water proof structure
 - Mono-block housing for maximum stability

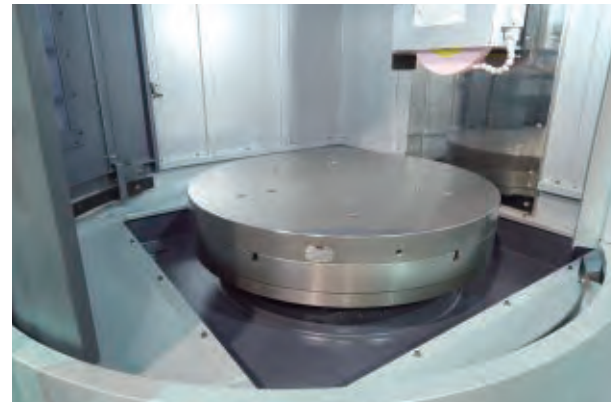

Model	Diameter(D1)	Height(H)	D2	D3	n	M	G	Net Weight	Controller (400V)	
EPY-300	300(11.81)	75(2.95)	160(6.30)	190(7.48)	4	10	4 (0.16)	40 kg / 88 lb	CGA	
EPY-400	400(11.75)	75(2.95)	210(7.87)	250(9.84)	6	12	4 (0.16)	73 kg / 161 lb	CGA	
EPY-500	500(19.69)	75(2.95)	320(12.60)	380(14.96)	6	12	4 (0.16)	115 kg / 254 lb	CGA	
EPY-600	600(23.62)	75(2.95)	350(13.78)	390(15.35)	6	12	4 (0.16)	165 kg / 364 lb	CGA	
EPY-700	700(27.56)	75(2.95)	400(15.75)	450(17.72)	6	16	4 (0.16)	265 kg / 584 lb	CGD	
EPY-800	800(31.50)	75(2.95)	450(17.72)	500(19.69)	6	16	4 (0.16)	295 kg / 650 lb	CGD	
EPY-1000	1000(39.37)	75(2.95)	550(21.65)	620(24.41)	8	16	4 (0.16)	460 kg / 1014 lb	CGD	
EPY-1200	1200(47.24)	80 (3.15)	Upon request						590 kg / 1298 lb	CGF
EPY-1500	1500(59.06)	80 (3.15)	Upon request						922 kg / 2028 lb	CGF

Unit: mm(in)



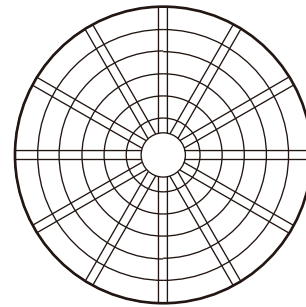
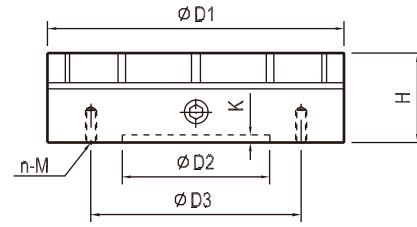

● **Circular permanent magnetic chuck with radial poles**

Use:

Clamping for grinding and turning of ring-shaped workpieces

Features:

- Max. magnetic clamping force up to 180 N/cm²
- Concentric grooves simplify the centring of workpiece
- Centre through hole is available on request for workpiece
- T-slots available on request for pole extensions allowing 3 sided access in single set-up

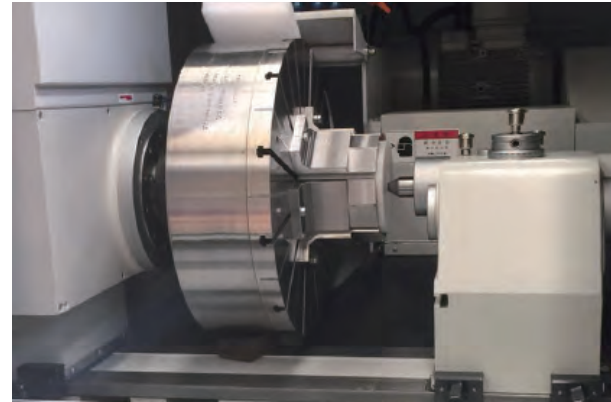

Model	Diameter(D)	Height	D2	D3	n	M	K	Net Weight
NR-100	100 (3.94)	60 (2.36)	60 (2.36)	85 (3.35)	4	6	4 (0.16)	3.3 kg / 7.26 lb
NR-130	130 (5.12)	60 (2.36)	50 (1.97)	100 (3.94)	4	6	4 (0.16)	6 kg / 13 lb
NR-150	150 (5.91)	60 (2.36)	90 (3.54)	115 (4.53)	4	8	4 (0.16)	8 kg / 18 lb
NR-160	160 (6.30)	60 (2.36)	120 (4.72)	140 (5.51)	4	8	4 (0.16)	10 kg / 22 lb
NR-200	200 (7.87)	60 (2.36)	160 (6.30)	180 (7.09)	4	8	4 (0.16)	14 kg / 31 lb
NR-250	250 (9.84)	60 (2.36)	200 (7.87)	230 (9.06)	4	10	4 (0.16)	23 kg / 51 lb
NR-300	300 (11.81)	80 (3.15)	250 (9.84)	270 (10.63)	7	12	4 (0.16)	43 kg / 95 lb
NR-320	320 (12.60)	80 (3.15)	250 (9.84)	270 (10.63)	6	12	4 (0.16)	50 kg / 110 lb
NR-350	350 (13.78)	80 (3.15)	250 (9.84)	280 (11.02)	6	12	4 (0.16)	59 kg / 130 lb
NR-400	400 (15.75)	80 (3.15)	200 (7.87)	260 (10.24) / 340 (13.39)	12	10	6 (1.81)	78 kg / 172 lb
NR-500	500 (19.69)	95 (3.74)	200 (7.87)	300 (11.81) / 400 (15.75)	12	10	8 (0.31)	146 kg / 321 lb
NR-600	600 (23.62)	95 (3.74)	250 (9.84)	350 (13.78) / 450 (17.72)	12	10	8 (0.31)	210 kg / 462 lb

Unit: mm(in)

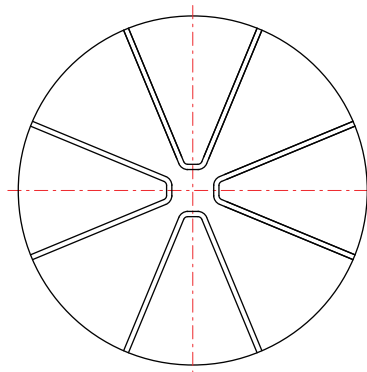
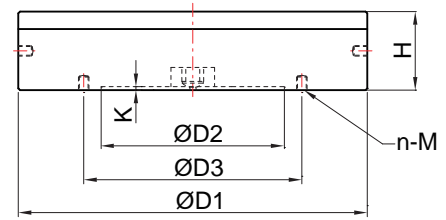

Turning

• Circular electromagnetic chuck with radial poles

Use:

Clamping for grinding of ring shaped work pieces

Features:

- Highest clamping force up to 160 N/cm²
- T-slot can be available as an option with pole extension for grinding wheel at three side operation
- Magnetic force cover the edge
- Real magnetic poles
- Coolant and water proof structure
- Minimum mechanical deformation with solid one-piece housing

Model	Diameter	Height	D2	D3	K	n	M	Voltage	Current	Net Weight
EMW-400	400 (15.75)	90 (3.54)	210 (8.27)	250 (9.84)	4 (0.16)	6	12	DC90-110V	1.4 A	76 kg / 167 lb
EMW-500	500 (19.69)	90 (3.54)	280 (11.02)	320 (12.60)	4 (0.16)	6	12	DC90-110V	1.8 A	120 kg / 264 lb
EMW-600	600 (23.62)	100 (3.94)	350 (13.78)	390 (15.35)	4 (0.16)	6	12	DC90-110V	2.5 A	195 kg / 429 lb
EMW-700	700 (27.56)	100 (3.94)	400 (15.75)	450 (17.72)	4 (0.16)	6	16	DC90-110V	3.2 A	265 kg / 583 lb
EMW-800	800 (31.50)	100 (3.94)	450 (17.72)	500 (19.69)	4 (0.16)	6	16	DC90-110V	4.0 A	365 kg / 803 lb
EMW-900	900 (35.43)	100 (3.94)	500 (21.65)	550 (23.62)	4 (0.16)	8	16	DC90-110V	5.0 A	474 kg / 1043 lb
EMW-1000	1000 (39.37)	100 (3.94)	550 (21.65)	600 (23.62)	4 (0.16)	8	16	DC90-110V	6.0 A	550 kg / 1210 lb
EMW-1250	1250 (49.21)	125 (4.92)						DC90-110V	8.8 A	1143 kg / 2515 lb
EMW-1350	1350 (53.15)	125 (4.92)						DC90-110V	10.0 A	1334 kg / 2934 lb
EMW-1500	1500 (59.06)	125 (4.92)			Upon request			DC90-110V	13.1 A	1646 kg / 3622 lb
EMW-1600	1600 (62.99)	125 (4.92)						DC90-110V	14.8 A	1873 kg / 4121 lb
EMW-1800	1800 (70.87)	125 (4.92)						DC90-110V	16.0 A	2371 kg / 5216 lb

Unit: mm(in)

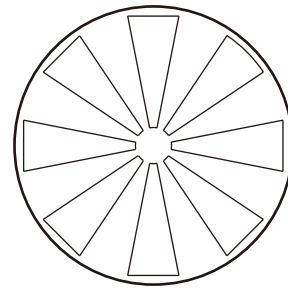
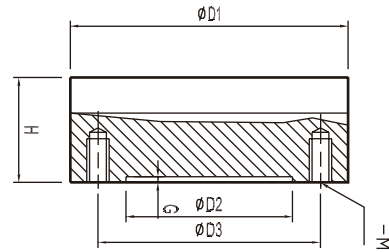

• **Circular electro-permanent magnetic chuck with radial poles**

Use:

Clamping for turning or grinding of ring shaped workpieces

Features:

- Max. magnetic clamping force up to 160 N/cm²
- Electro-permanent technology with no deformation owing to the rise of temperature
- Can eliminate the residual magnetism from the workpiece
- T-slot available on request for pole extensions allowing 3 sided access in single set-up
- Mono-block housing for maximum stability



Model	Size (D1)	Height (H)	D2	D3	n	M	G	Pole No.	Net weight	Controller (400V)
EPW-G/S	300 (11.81)	105 (4.13)	160 (6.30)	190 (7.48)	5	12	4 (0.16)	10	55 kg / 121 lb	CGA
EPW-G/S	400 (11.75)	115 (4.53)	200 (7.87)	280 (11.02)	6	12	4 (0.16)	12	107 kg / 236 lb	CGA
EPW-G/S	500 (19.68)	120 (4.72)	280 (11.02)	320 (12.6)	7	12	4 (0.16)	14	158 kg / 348 lb	CGA
EPW-G/S	600 (23.62)	120 (4.72)	350 (13.78)	390 (15.35)	8	12	4 (0.16)	16	227 kg / 499 lb	CGA
EPW-G/S	700 (27.56)	120 (4.72)	400 (15.75)	450 (17.72)	8	16	4 (0.16)	16	310 kg / 682 lb	CGD
EPW-G/S	800 (31.50)	120 (4.72)	450 (17.72)	500 (19.69)	8	16	4 (0.16)	16	404 kg / 889 lb	CGD
EPW-G/S	1000 (39.37)	120 (4.72)	550 (21.65)	620 (24.41)	8	16	4 (0.16)	24	632 kg / 1391 lb	CGD
EPW-G/S	1250 (49.21)	125 (4.92)							1076 kg / 2367 lb	
EPW-G/S	1600 (62.99)	125 (4.92)							1763 kg / 3879 lb	Upon request
EPW-G/S	1800 (70.87)	125 (4.92)							2232 kg / 4910 lb	
EPW-G/S	2000 (78.74)	125 (4.92)							2755 kg / 6061 lb	

Upon request

Unit: mm(in)

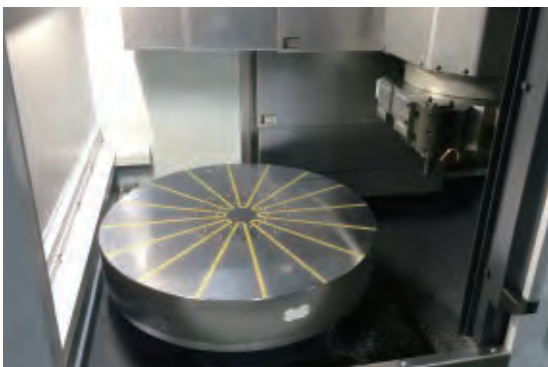

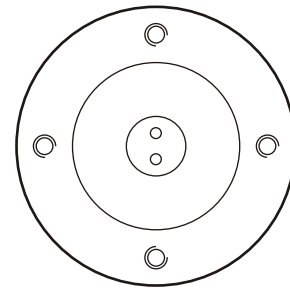
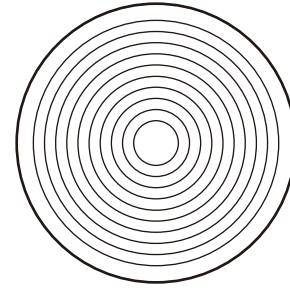
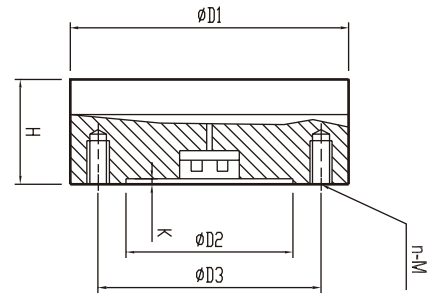

• Circular electromagnetic chuck with concentric poles

Use:

Clamping for grinding of disc shaped workpieces

Features:

- Pole pitch 4+12 mm
- Highest uniform clamping force up to 120 N/cm²
- Gap free construction pole plate
- Real magnetic poles
- Coolant and water proof structure
- Minimum mechanical deformation with solid one-piece housing

Model	Diameter	Height	D2	D3	K	n	M	Voltage	Current	Net Weight
EMY-300	300 (11.81)	90 (3.54)	160 (6.30)	190 (7.48)	3 (0.12)	4	12	110 V	0.82 A	45 kg / 99 lb
EMY-400	400 (15.75)	105 (4.13)	210 (8.27)	250 (9.84)	4 (0.16)	6	12	110 V	1.36 A	92 kg / 202 lb
EMY-500	500 (19.69)	105 (4.13)	280 (11.02)	320 (12.60)	4 (0.16)	6	12	110 V	1.73 A	144 kg / 317 lb
EMY-600	600 (23.62)	115 (4.53)	350 (13.78)	390 (15.35)	4 (0.16)	6	16	110 V	3.50 A	229 kg / 504 lb
EMY-700	700 (27.56)	120 (4.72)	400 (15.75)	450 (17.72)	4 (0.16)	6	16	110 V	4.00 A	326 kg / 717 lb
EMY-800	800 (31.50)	120 (4.72)	450 (17.72)	500 (19.69)	4 (0.16)	6	16	110 V	4.50 A	426 kg / 937 lb
EMY-900	900 (35.43)	120 (4.72)	550 (21.65)	600 (23.62)	4 (0.16)	6	16	110 V	5.50 A	539 kg / 1186 lb
EMY-1000	1000 (39.37)	120 (4.72)	550 (21.65)	620 (24.41)	4 (0.16)	8	16	110 V	6.00 A	665 kg / 1463 lb
EMY-1100	1100 (43.31)	125 (4.92)						110 V	7.50 A	839 kg / 1858 lb
EMY-1200	1200 (47.24)	125 (4.92)						110 V	8.73 A	998 kg / 2200 lb
EMY-1300	1300 (51.18)	125 (4.92)						110 V	10.00 A	1171 kg / 2576 lb
EMY-1400	1400 (55.12)	125 (4.92)						110 V	12.00 A	1358 kg / 2987 lb
EMY-1500	1500 (59.06)	125 (4.92)						110 V	13.09 A	1545 kg / 3399 lb
EMY-1600	1600 (62.99)	125 (4.92)						110 V	14.82 A	1760 kg / 3872 lb

Upon request

Unit: mm(in)

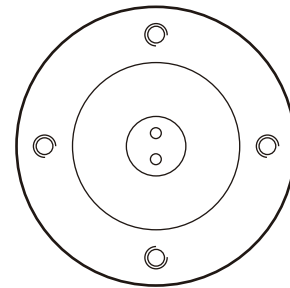
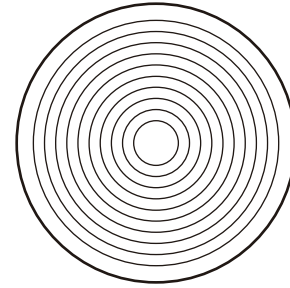
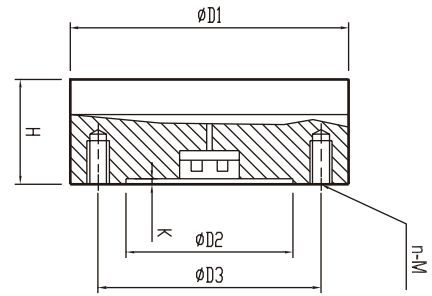

● **Circular electro-permanent magnetic chuck with concentric poles**

Use:

Clamping for grinding of disc shaped workpieces

Features:

- Pole pitch 4+12 mm
- Highest uniform clamping force up to 120 N/cm²
- Electro-permanent technology with no deformation owing to the rise of the temperature
- Gap free construction pole plate
- Real magnetic poles
- Coolant and water proof structure
- Minimum mechanical deformation with solid one-piece housing

Model	Diameter	Height	D2	D3	K	n	M	Net Weight	Controller Unit
EPQ-400	400 (15.75)	100 (3.94)	210 (8.27)	250 (9.84)	4 (0.16)	6	12	85 kg / 187 lb	CGA
EPQ-500	500 (19.69)	100 (3.94)	280 (11.02)	320 (12.60)	4 (0.16)	6	12	135 kg / 298 lb	CGA
EPQ-600	600 (23.62)	100 (3.94)	350 (13.78)	390 (15.35)	4 (0.16)	6	12	195 kg / 430 lb	CGA
EPQ-700	700 (27.56)	100 (3.94)	400 (15.75)	450 (17.72)	4 (0.16)	6	16	265 kg / 584 lb	CGA
EPQ-800	800 (31.50)	100 (3.94)	450 (17.72)	500 (19.69)	4 (0.16)	6	16	365 kg / 805 lb	CGD
EPQ-900	900 (27.56)	100 (3.94)	500 (19.69)	560 (22.05)	4 (0.16)	8	16	440 kg / 970 lb	CGD
EPQ-1000	1000 (39.37)	100 (3.94)	550 (21.65)	620 (24.41)	4 (0.16)	8	16	550 kg / 1213 lb	CGD
EPQ-1100	1100 (43.31)	125 (4.92)						830 kg / 1830 lb	CGD
EPQ-1200	1200 (47.24)	125 (4.92)						990 kg / 2183 lb	CGF
EPQ-1300	1300 (51.18)	125 (4.92)						1160 kg / 2557 lb	CGF
EPQ-1400	1400 (55.12)	125 (4.92)					Upon request	1350 kg / 2976 lb	CGF
EPQ-1500	1500 (59.06)	125 (4.92)						1550 kg / 3417 lb	CGF
EPQ-1600	1600 (62.99)	125 (4.92)						1760 kg / 3880 lb	CGF

Unit: mm(in)

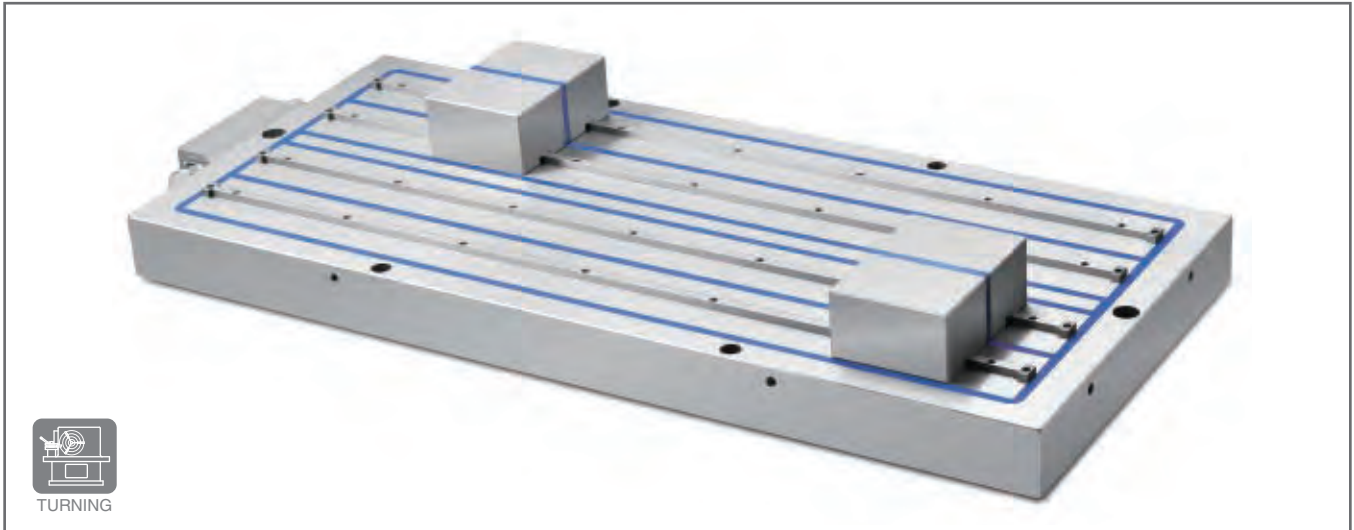

● Electro-permanent magnetic chuck for heavy turning

Use:

Universal clamping for heavy turning

Features:

- Sliding pole extension
- Max. magnetic clamping force up to 180 N/cm²
- Highly concentrated magnetic field with low flux depth
- Prevents magnetization of tooling
- Coolant proof structure
- Easy to deploy
- High precision with no residual magnetism
- Easy and economic to use with different modules combination

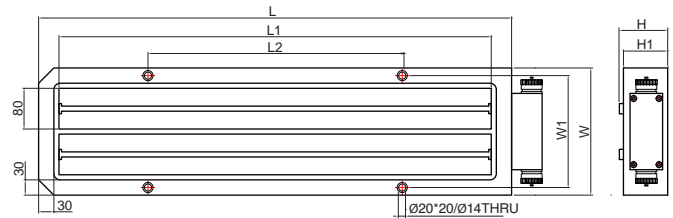

■ Sliding pole extensions

Model	Width(W)	Length(L)	L1	L2	W1	Height(H)	H	Net weight
PR80-2545	250 (9.8)	450 (17.7)	370 (14.6)	350 (13.8)	220 (8.7)	80 (3.1)	87 (3.4)	73 kg / 160 lb
PR80-25100	250 (9.8)	930 (36.6)	850 (33.5)	500 (19.7)	220 (8.7)	80 (3.1)	87 (3.4)	160 kg / 352 lb
PR80-46100	460 (18.1)	1040 (40.9)	950 (37.4)	500 (19.7)	430(16.9)	80 (3.1)	87 (3.4)	228 kg / 502 lb

Unit: mm(in)

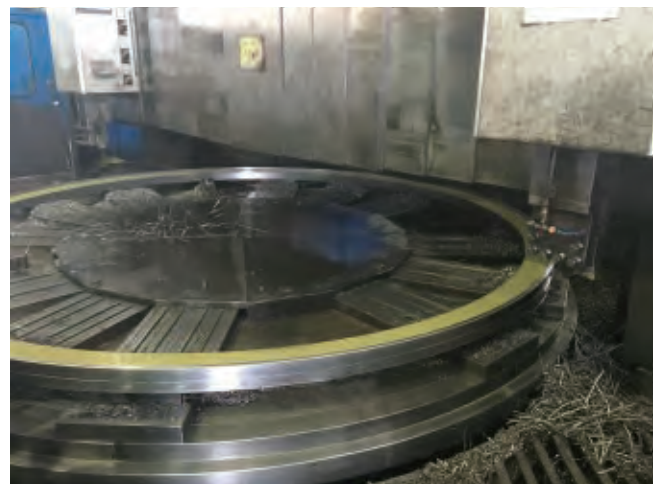
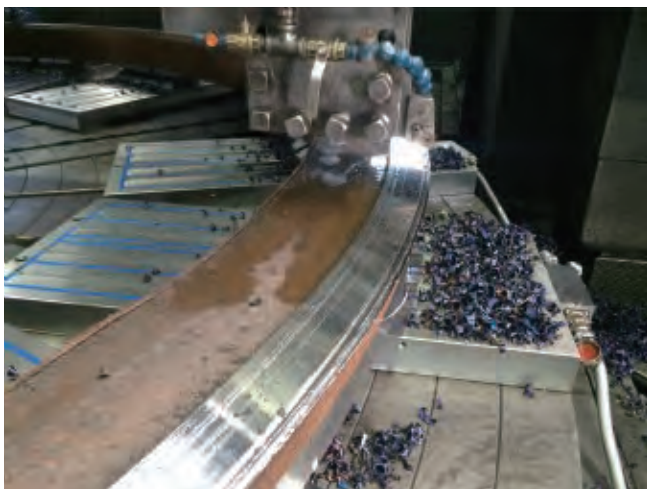

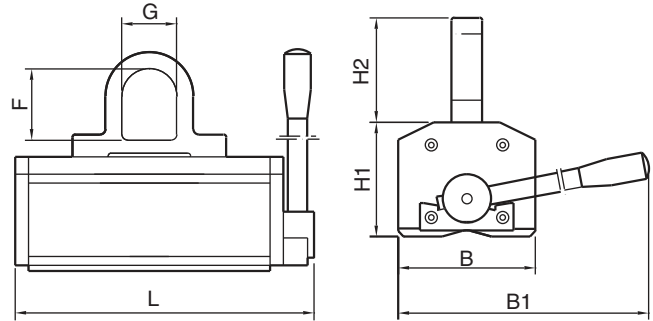

● Permanent lifting magnet

Use:

For lifting ferromagnetic material, bar stock, cold rolled

Features:

- High power to weight ratio
- Compact and light
- Minimum of 3X safety factor
- Suitable for flat and round material
- Maintenance free design
- Safety device prevent accidental deactivation
- Can be switched off by one hand only



Model	Safe Working Load	Width	Length	H1	H2	B1	F	G	Net Weight
PLM-100	100 kg / 220 lb	70 (2.76)	130 (5.12)	60 (2.36)	53 (2.09)	176 (6.93)	35 (1.38)	28 (1.10)	3.5 kg / 8 lb
PLM-300	300 kg / 660 lb	95 (3.74)	205 (8.07)	83 (3.27)	70 (2.76)	220 (8.66)	47 (1.85)	40 (1.57)	10 kg / 22 lb
PLM-600	600 kg / 1320 lb	125 (4.92)	272 (10.71)	104 (4.09)	95 (3.74)	296 (11.65)	64 (2.52)	50 (1.97)	23 kg / 51 lb
PLM-1000	1000 kg / 2200 lb	160 (6.30)	318 (12.52)	140 (5.51)	95 (3.74)	410 (16.14)	64 (2.52)	50 (1.97)	44 kg / 97 lb
PLM-2000	2000 kg / 4400 lb	160 (6.30)	496 (19.53)	140 (5.51)	120 (4.72)	508 (20.00)	80 (3.15)	60 (2.36)	72 kg / 158 lb
PLM-3000	3000 kg / 6600 lb	230 (9.06)	510 (20.08)	212 (8.35)	155 (6.10)	600 (23.62)	100 (3.94)	70 (2.76)	160 kg / 352 lb
PLM-5000	5000 kg / 11000 lb	360 (14.17)	725 (28.54)	261 (10.28)	180 (7.09)	980 (38.58)	100 (3.94)	70 (2.76)	450 kg / 990 lb

Model	Load Plate Max	Plate Min Thickness	Plate Max Length	Load Round Max Round	Min Thickness	Round Max Dia.
PLM-100	100 kg / 220 lb	15 (0.59)	1000 (39.37)	40 kg / 88 lb	8 (0.31)	150 (5.9)
PLM-300	300 kg / 660 lb	20 (0.79)	1500 (59.06)	120 kg / 264 lb	12 (0.47)	180 (7.09)
PLM-600	600 kg / 1320 lb	25 (0.98)	2000 (78.74)	240 kg / 528 lb	20 (0.79)	250 (9.84)
PLM-1000	1000 kg / 2200 lb	40 (1.57)	3000 (118.11)	400 kg / 880 lb	25 (0.98)	280 (11.02)
PLM-2000	2000 kg / 4400 lb	55 (2.17)	3000 (118.11)	800 kg / 1760 lb	35 (1.38)	350 (13.78)
PLM-3000	3000 kg / 6600 lb	70 (2.76)	3500 (137.8)	1200 kg / 2640 lb	45 (1.77)	400 (15.75)
PLM-5000	5000 kg / 11000 lb	85 (3.35)	4000 (157.48)	2000 kg / 4400 lb	55 (2.17)	450 (17.7)

Unit: mm(in)

PLM-T

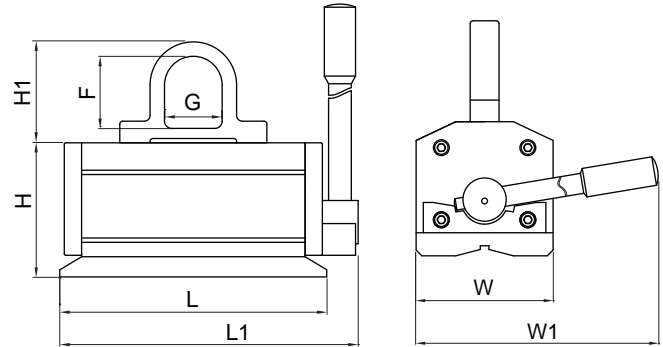

Lifting magnets

● **Permanent lifting magnet for safe handling of thin plates**

Use:

Plate handling for thin plates
De-stack down to 10 mm plates

Features:

- Special design allows controlled depth of flux
- High power with shallow flux depth, Specifically designed for de-stacking thin plates
- High capacity with low flux depth



Model	Width(W)	Length(L)	Height(H)	H1	W1	L1	G	F	Net Weight
PLM-T-150	95 (3.74)	185 (7.28)	93 (3.66)	70 (2.76)	160 (6.30)	208 (8.19)	40 (1.57)	50 (1.97)	10 kg / 22 lb
PLM-T-300	125 (4.92)	250 (9.84)	114 (4.49)	95 (3.74)	296 (11.65)	275 (10.83)	50 (1.97)	65 (2.56)	19 kg / 42 lb

Model	Flat load Max	Min Thickness	Max Length	Load Round Max	Round Min Dia.	Round Max Dia.
PLM-T-150	150 kg / 330 lb	10 (0.39)	1200 (47.24)	60 kg / 132 lb	60 (2.36)	180 (7.09)
PLM-T-300	300 kg / 660 lb	12 (0.47)	1500 (59.06)	120 kg / 264 lb	60 (2.36)	180 (7.09)

Unit: mm(in)

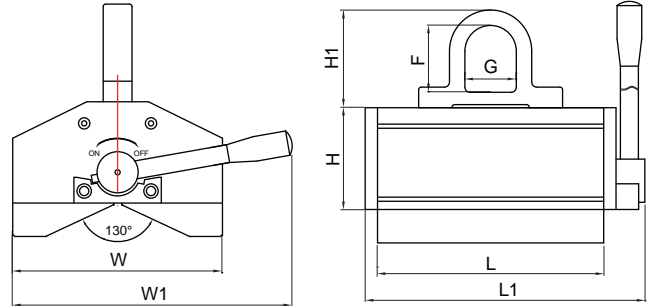

Permanent lifting magnet for safe handling of round work piece

Use:

Round or flat, the "safest" way to handle a load.

Features:

- Larger V shape pole shoes than standard PLM to ensure safer conditions
- Higher performance on rounds than standard PLM
- Larger V for higher stability on round stock
- Low flux depth allowing de-stacking of thin loads



Model	Width(W)	Length(L)	Height(H)	H1	W1	L1	G	F	Net Weight
PLM-R-300	123 (4.84)	155 (6.10)	94 (3.70)	70 (2.76)	220 (8.66)	215 (8.46)	40 (1.57)	50 (1.97)	15 kg / 33 lb
PLM-R-600	204 (8.03)	220 (8.66)	131 (5.16)	95 (3.74)	296 (11.65)	272 (10.71)	50 (1.97)	65 (2.56)	38 kg / 84 lb
PLM-R-1000	280 (11.02)	252 (9.92)	178 (7.01)	95 (3.74)	410 (16.14)	252 (9.92)	50 (1.97)	65 (2.56)	85 kg / 187 lb
PLM-R-2000	280 (11.02)	252 (9.92)	178 (7.01)	95 (3.74)	508 (20.00)	496 (19.53)	60 (2.36)	80 (3.15)	150 kg / 330 lb
PLM-R-3000	444 (17.48)	429 (16.89)	293 (11.54)	155 (6.10)	600 (23.62)	509 (20.04)	70 (2.76)	100 (3.94)	340 kg / 748 lb

Model	Flat load Max	Min Thickness	Max Length	Load Round Max	Round Min Dia.	Round Max Dia.
PLM-R-300	300 kg/660 lb	20 (0.79)	1500 (59.06)	150 kg/330 lb	60 (2.36)	200 (7.87)
PLM-R-600	600 kg/1320 lb	25 (0.98)	2000 (78.74)	300 kg/660 lb	60 (2.36)	300 (11.81)
PLM-R-1000	1000 kg/2200 lb	40 (1.57)	3000 (118.11)	500 kg/1100 lb	80 (3.15)	360 (14.17)
PLM-R-2000	2000 kg/4400 lb	55 (2.17)	3000 (118.11)	1000 kg/2200 lb	80 (3.15)	460 (18.11)
PLM-R-3000	3000 kg/6600 lb	70 (2.76)	3500 (137.8)	1500 kg/3300 lb	100 (3.94)	560 (22.05)

Unit: mm(in)

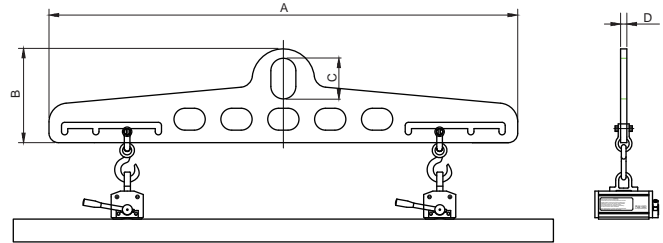
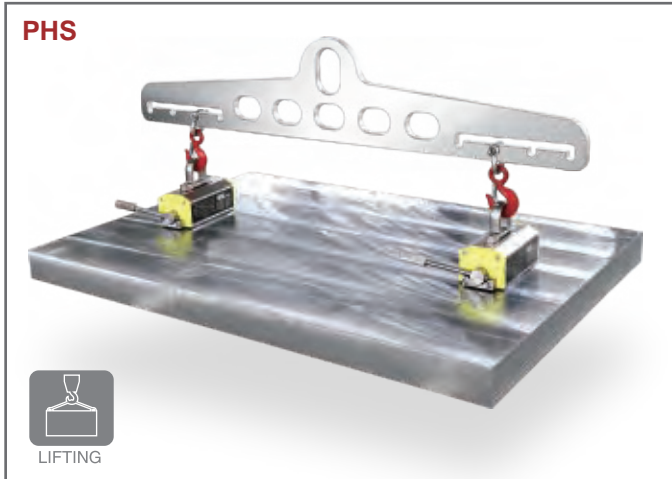

● PHS - PLM Fixed Beam

Features:

- The PHS spreader beam allows for the mounting of 2 PLM lifters increasing the load handling characteristics without complicating the overall simplicity of the process.
- PHS 500 handles loads up to 500 kgs and 3000mm while PHS 2000 handles loads up to 2000kg and 5000mm in length.

	PHS 500	PHS 2000
A (mm)	1500	1900
B (mm)	300	415
C (mm)	130	160
D (mm)	15	20
Weight (kg)	34	75

	PHS 500	PHS 500	PHS 2000	PHS 2000
In Combination with:	2 x PLM-300	2 x PLM-600	2 x PLM-600	2 x PLM-1000
Load (kg)	480	960	960	1600
Max Length (mm)	3000	3000	3000	3000
Max Width (mm)	1500	1500	1500	1500
Plates				
Load (kg)	240	480	480	750
Rounds				
Max Length (mm)	3000	3000	3000	3000

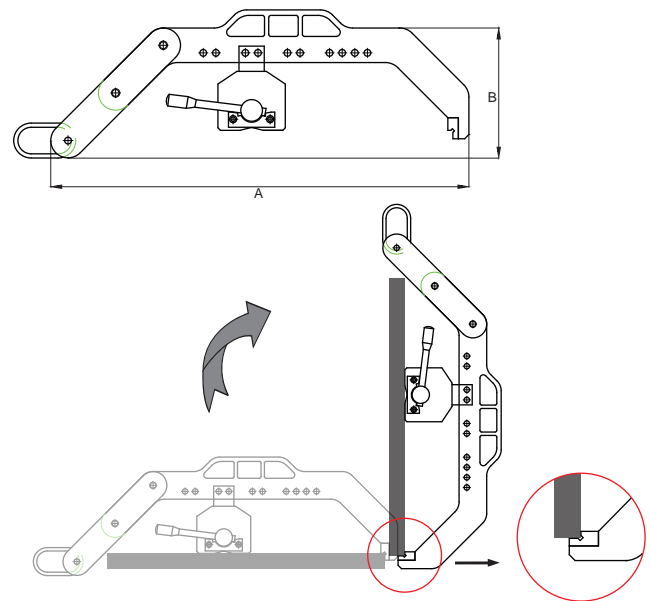

● PVS - PLM Vertical System

Features:

- PVS system is designed to rotate flat plates from horizontal to vertical and back.
- Can be used to flip parts over in a safe manner using simple stalls
- PVS is adaptable to workpieces of different sizes, changing the position of locking pins.
- PVS is available for PLM 300/600/1000.

Technical characteristics

Model	PVS 300	PVS 600	PVS 1000
A (mm)	695	892	995
B (mm)	250	320	352
C (mm)	110	140	140
D (mm)	100	160	252
Weight (kg)	20	41	63
Load Max (kg)	210	420	700
Max length plate (mm)	800	1000	1000
Max height plate (mm)	550	700	800



CUA / CUD / CUT

BRISC®

Control unit



● One channel control unit

Use:
Electro-permanent magnetics modules for milling

Features:

- Multiple input voltage choices
- Micro computer controls self testing and magnetizing detection
- Good for both 50 Hz and 60 Hz
- PLC connection built in
- Safe and reliable
- Including 5 meters power cable and 5 meters discharge cable

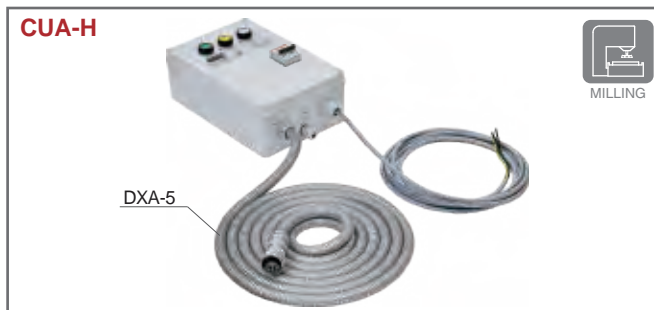

Model	Length	Width	Height	Net weight	Box
CUA-A	325 (12.80)	170 (6.69)	90 (3.54)	3.4 kg / 7.5 lb	Metal
CUA-H	250 (9.84)	150 (5.91)	100 (3.94)	1.6 kg / 3.5 lb	Plastic

Voltage	Max. Pole No. / channel	Pole size
220 V	56	50 x 50 mm
400 / 480 V	84	50 x 50 mm



● Two channels control unit

Use:
Electro-permanent magnetics modules for milling

Features:

- Multiple input voltage choices
- Micro computer controls self testing and magnetizing detection
- Good for both 50 Hz and 60 Hz
- PLC connection built in
- Safe and reliable
- Including 5 meters power cable and 5 meters discharge cable

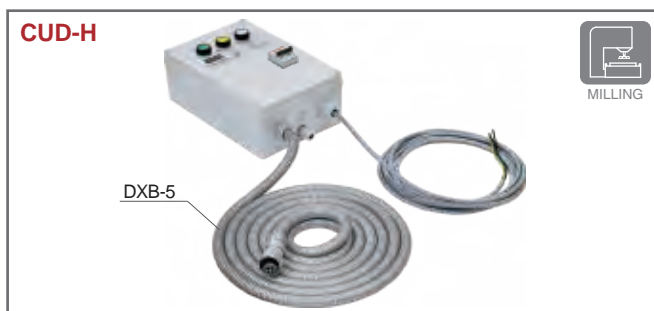

Model	Length	Width	Height	Net weight	Box
CUD-A	325 (12.80)	170 (6.69)	90 (3.54)	3.4 kg / 7.5 lb	Metal
CUD-H	300 (11.81)	200 (7.87)	105 (4.13)	2.0 kg / 4.4 lb	Plastic

Voltage	Max. Pole No. / channel	Pole size
220 V	56	50 x 50 mm
400 / 480 V	84	50 x 50 mm



Model	Length	Width	Height	Net weight	Box
CUT-A	325 (12.80)	170 (6.69)	90 (3.54)	3.4 kg / 7.5 lb	Metal

● Two channels control unit

Use:
Electro-permanent magnetics modules for milling

Features:

- Multiple input voltage choices
- Micro computer controls self testing and magnetizing detection
- Good for both 50 Hz and 60 Hz
- PLC connection built in
- Safe and reliable
- Including 5 meters power cable and 5 meters discharge cable
- With channel selection function

Voltage	Max. Pole No. / channel	Pole size
220 V	56	50 x 50 mm
400 / 480 V	84	50 x 50 mm



● One channel control unit

Use:
Electro-permanent magnetics modules for grinding

- Features:**
- Multiple input voltage choices
 - Micro computer controls self testing and magnetizing detection
 - Good for both 50 Hz and 60 Hz
 - PLC connection built in
 - Safe and reliable
 - Strength adjustable

Model	Length	Width	Height	Net weight	Applicatin
CGA-DT	250 (9.84)	150 (5.91)	100 (3.94)	1.6 kg / 3.5 lb	external
CGA-M	210 (8.27)	110 (4.33)	100 (3.94)	1 kg / 2.2 lb	internal

Voltage	Max. current per channel	Max. Pole No. per channel	Pole size
220 V	50 A	56	50 x 50 mm
400 / 480 V	50 A	84	50 x 50 mm



● Two channels control unit

Use:
Electro-permanent magnetics modules for grinding

- Features:**
- Multiple input voltage choices
 - Micro computer controls self testing and magnetizing detection
 - Good for both 50 Hz and 60 Hz
 - PLC connection built in
 - Safe and reliable
 - Strength adjustable

Model	Length	Width	Height	Net weight	Applicatin
CGD-DT	300 (11.81)	200 (7.87)	105 (4.13)	2.0 kg / 4.4 lb	external
CGD-M	260 (8.27)	110 (4.33)	100 (3.94)	1 kg / 2.2 lb	internal

Voltage	Max. current per channel	Max. Pole No. per channel	Pole size
220 V	50 A	56	50 x 50 mm
400 / 480 V	50 A	84	50 x 50 mm



● Eight channels junction box

Use:
Fast connections between chucks and control unit

- Features:**
- Die cast aluminum box
 - IP65 water resistant
 - HARTING connector for quick connection

Model	Length	Width	Height	Net weight
JB-22	280 (11.02)	230 (9.06)	110 (4.33)	4.5 kg / 9.9 lbs

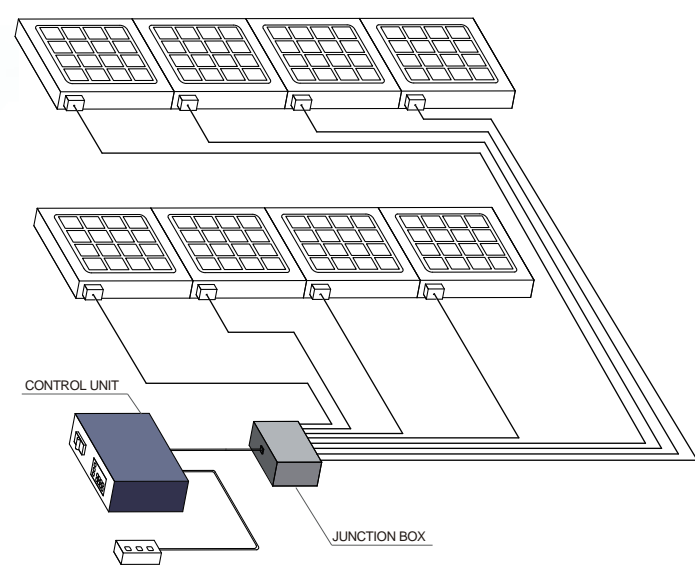



• Multi-channels control unit

Use:
Selectable channel multi-channel controller for electro-permanent magnets

- Features:**
- Multiple input voltage choices
 - Micro computer controls self testing and magnetizing detection
 - Good for both 50 Hz and 60 Hz
 - PLC connection built in
 - Safe and reliable
 - With channel selection function
 - Can be used jointly

Model	Length	Width	Height	Net weight	Channels
CUF	383 (15.08)	289 (11.38)	129 (5.08)	8 kg / 17.6 lb	4
CUS	383 (15.08)	289 (11.38)	129 (5.08)	8 kg / 17.6 lb	6
CUE	383 (15.08)	289 (11.38)	129 (5.08)	8 kg / 17.6 lb	8
CGF	383 (15.08)	289 (11.38)	129 (5.08)	8 kg / 17.6 lb	4
CGS	383 (15.08)	289 (11.38)	129 (5.08)	8 kg / 17.6 lb	6
CGE	383 (15.08)	289 (11.38)	129 (5.08)	8 kg / 17.6 lb	8

Voltage	Max. Pole No. / channel	Pole size
220 V	56	50 x 50 mm
400 / 480 V	84	50 x 50 mm



• Remote control

Use:
For wire remote control

- Features:**
- Small and compact
 - With magnetic plate on the rear for ease of attachment

Model	Length	Width	Height	Strength adjustable	Channel Selection
RMC-1	136 (5.35)	66 (2.60)	41 (1.61)	Yes	No
RMC-2	136 (5.35)	66 (2.68)	55 (2.17)	Yes	No
RMC-3	136 (5.35)	66 (2.60)	41 (1.61)	No	No
RMC-9	136 (5.35)	66 (2.60)	41 (1.61)	Yes	Yes
RMC-10	136 (5.35)	66 (2.60)	41 (1.61)	No	Yes





● Control unit for electromagnetic chucks

Model	Length	Width	Height	Strength adjustable
CEB	260 (10.2)	160 (6.3)	90 (3.5)	Yes

Use:

Use with any electromagnetic chucks with input of 130 VAC and output 115 VDC and capacity of up to 500 watts

Features:

- External use design
- Push button control allows easy selection of full, residual, variable, and release positions
- Automatic release cycle assures workpiece release, while freeing machine operators from manual demagnetizing operations
- Current sense and E-stop interlock with machine
- Up to 16 pole reversal programs



● Control unit for electro-permanent magnetic chucks

Model	Length	Width	Height	Net weight
CUK-A	250 (9.8)	195 (7.7)	106 (4.2)	3.2 kg / 7.1 lb

Use:

Electro-permanent magnetics modules for grinding and milling

Features:

- Universal use for all magnet types
- Multiple input voltage choices
- Micro computer controls self testing and magnetizing detection
- Good for both 50 Hz and 60 Hz
- PLC connection built in
- Safe and reliable
- Multi-demag pattern for different material

PTA / PTB

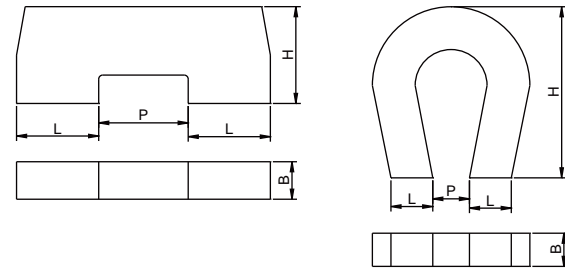
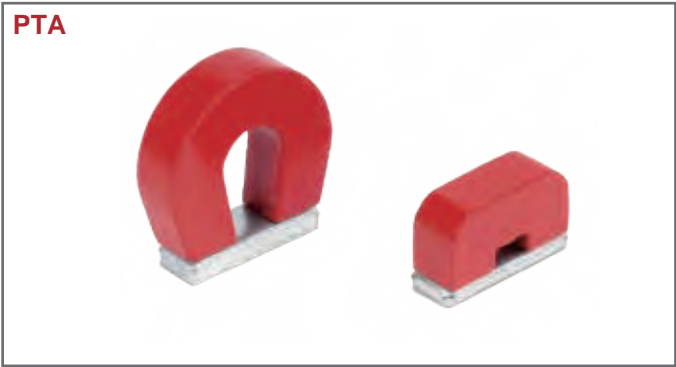

• Pocket magnet

Use:
For lifting, sorting out, positioning

- Features:**
- Handy bridge magnet with strong clamping force
 - Material alnico
 - Maximum operating temperature to 450 °C

Model	Height	Magnetic Pitch(P)	Cross-section(L)	Cross-section(B)	Clamping Force	Net Weight
PTA-1	11 (0.43)	9 (0.35)	9 (0.35)	8 (0.31)	13 N	17 g / 0.04 lb
PTA-2	25 (0.98)	6.5 (0.26)	8.5 (0.33)	6.5 (0.26)	24 N	32 g / 0.07 lb

Unit: mm(in)

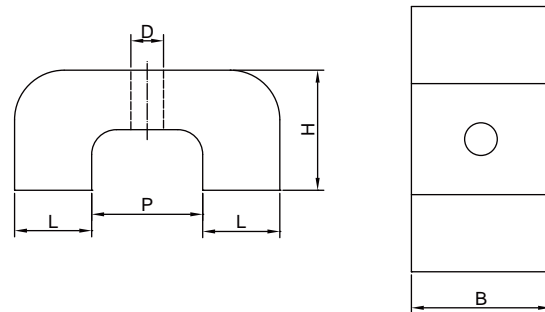

• Strong magnet

Use:
For lifting, sorting out, positioning

- Features:**
- Bridge shape magnet
 - Through hole for mounting
 - High clamping force
 - Maximum operating temperature to 450 °C

Model	Height(H)	Magnetic Pitch(P)	Cross-section(L)	Cross-section(B)	Diameter	Clamping Force	Net Weight
PTB-1	20 (0.79)	15 (0.59)	8 (0.31)	20 (0.79)	5 (0.20)	45N	65 g / 0.14 lb
PTB-2	25 (0.98)	20 (0.79)	10 (0.39)	25 (0.98)	5 (0.20)	90N	150 g / 0.33 lb
PTB-3	30 (1.18)	22 (0.87)	11 (0.43)	30 (1.18)	5 (0.20)	120N	220 g / 0.49 lb
PTB-4	35 (1.38)	35 (1.38)	11 (0.43)	44.5 (1.75)	2 * 8 (0.31)	230N	380 g / 0.84 lb
PTB-5	41 (1.61)	41 (1.61)	15 (0.59)	57 (2.24)	2 * 8 (0.31)	320N	1600 g / 3.53 lb
PTB-6	54.5 (2.15)	48 (1.89)	15 (0.59)	82 (3.23)	2 * 11 (0.43)	470N	2000 g / 4.41 lb

Unit: mm(in)

PTC / PTD



● Bar magnet

Use:
To line up individual magnet in any desired length

- Features:**
- Cross section around
 - Maximum operating temperature to 450 °C
 - Axially magnetized
 - Material alnico

Model	Diameter	Height(H)	Net Weight
PTC-1	6 (0.24)	20 (0.79)	10 g / 0.02 lb
PTC-2	8 (0.31)	25 (0.98)	15 g / 0.03 lb
PTC-3	10 (0.39)	30 (1.18)	30 g / 0.07 lb
PTC-4	4 (0.16)	10 (0.39)	2 g / 0.004 lb
PTC-5	5 (0.20)	10 (0.39)	3 g / 0.007lb
PTC-6	6 (0.24)	10 (0.39)	3 g / 0.0007 lb

Unit: mm(in)

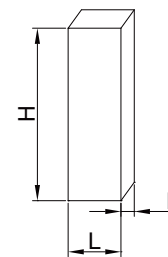
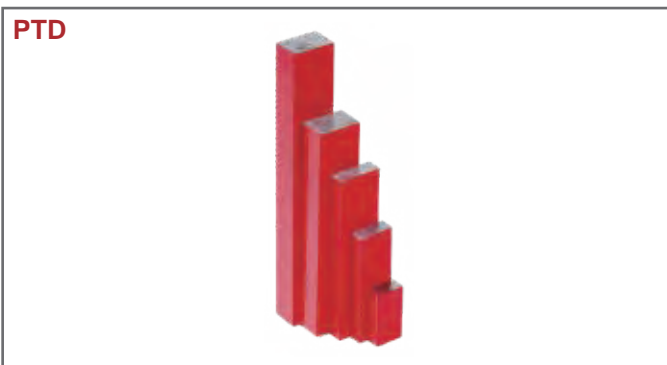

● Rectangular bar magnet

Use:
To line up individual magnet in any desired length

- Features:**
- Rectangular cross-section
 - Maximum operating temperature to 450 °C
 - Axially magnetized
 - Material alnico

Model	Length(L)	Width(B)	Height(H)	Net Weight
PTD-1	10 (0.39)	5 (0.20)	20 (0.79)	16 g / 0.04 lb
PTD-2	12.5 (0.49)	5 (0.20)	40 (1.57)	37 g / 0.08 lb
PTD-3	12 (0.47)	5 (0.20)	60 (2.36)	50 g / 0.11 lb
PTD-4	15 (0.59)	10 (0.39)	51 (2.01)	120 g / 0.26 lb
PTD-5	15 (0.59)	10 (0.39)	75 (2.95)	168 g / 0.37 lb
PTD-6	15 (0.59)	5 (0.20)	60 (2.36)	66 g / 0.15 lb
PTD-7	15 (0.59)	10 (0.39)	100 (3.94)	230 g / 0.51 lb

Unit: mm(in)

PTE / PTF / PTG



● Pot magnet with inner thread

Use:
For installation in apparatus, hold, position

- Features:**
- Maximum operating temperature to 450 °C
 - Material alnico

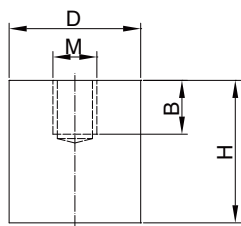

Model	Diameter (D)	Height (H)	Thread (M)	Clamping Force	Thread Height (B)	Net Weight
PTE-1	17 (0.67)	16 (0.63)	M6	18 N	4 (0.16)	26 g / 0.04 lb
PTE-2	21 (0.83)	19 (0.75)	M6	28 N	5 (0.20)	50 g / 0.07 lb
PTE-3	27 (1.06)	25 (0.98)	M6	65 N	6 (0.24)	110 g / 0.07 lb
PTE-4	35 (1.38)	30 (1.18)	M6	115 N	9 (0.35)	215 g / 0.07 lb
PTE-5	65 (2.56)	43 (1.69)	M12	400 N	13 (0.51)	1080 g / 0.07 lb

Unit: mm(in)



● Shallow pot magnet with through hole

Use:
For installation in apparatus

- Features:**
- Maximum operating temperature to 450 °C
 - Material alnico

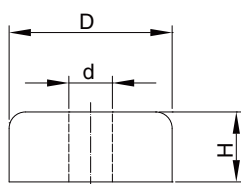

Model	Diameter (D)	Height (H)	Hole Diameter (d)	Clamping Force	Net Weight
PTF-1	19 (0.75)	8 (0.31)	3.5 (0.14)	30 N	18 g / 0.04 lb
PTF-2	29 (1.14)	9 (0.35)	5 (0.20)	55 N	46 g / 0.10 lb
PTF-3	38 (1.50)	10.5 (0.41)	5 (0.20)	95 N	97 g / 0.21 lb

Unit: mm(in)



● Button magnet with through hole

Use:
For laboratory use, measure, position

- Features:**
- Shared flat way through hole for mounting
 - Maximum operating temperature to 450 °C
 - Material alnico

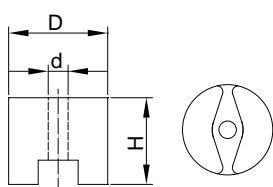

Model	Diameter (D)	Height (H)	Hole Diameter (d)	Clamping Force	Net Weight
PTG-1	13 (0.51)	10 (0.39)	4.2 (0.17)	7 N	7 g / 0.01 lb
PTG-2	19 (0.75)	13 (0.51)	5.4 (0.21)	19 N	20 g / 0.04 lb
PTG-3	25 (0.98)	16 (0.63)	5.4 (0.21)	29 N	56 g / 0.12 lb
PTG-4	32 (1.26)	25 (0.98)	7 (0.28)	66 N	133 g / 0.29 lb

Unit: mm(in)

PTH / PTJ

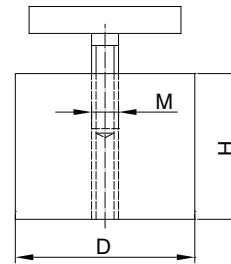

● Strong pot magnet with inner thread

Use:

As holding magnet

Features:

- Strong clamping force
- Grab bar also serves to facilitate the magnets and pull the trigger from the workpiece
- Maximum operating temperature to 350 °C

Model	Diameter(D)	Height(H)	Thread	Clamping Force	Net Weight
PTH-1	26 (1.02)	25 (0.98)	M6	100 N	80 g / 0.17 lb
PTH-2	30 (1.18)	25 (0.98)	M6	150 N	110 g / 0.24 lb
PTH-3	40 (1.57)	40 (1.57)	M8	300 N	240 g / 0.53 lb
PTH-4	50 (1.97)	40 (1.57)	M8	500 N	500 g / 1.10 lb

Unit: mm(in)

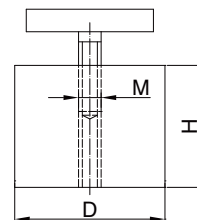

● Strong pot magnet with inner thread

Use:

As holding magnet

Features:

- Strong clamping force
- Grab bar also serves to facilitate the magnets and pull the trigger from the workpiece
- Maximum operating temperature to 350 °C

Model	Diameter(D)	Height(H)	Thread	Clamping Force	Net Weight
PTJ-1	44 (1.73)	44 (1.73)	M8	320 N	900 g / 1.98 lb
PTJ-2	54 (2.12)	50 (1.97)	M8	470 N	1200 g / 2.65 lb
PTJ-3	70 (2.76)	63 (2.48)	M8	980 N	2600 g / 5.73 lb

Unit: mm(in)

PTN / PTP

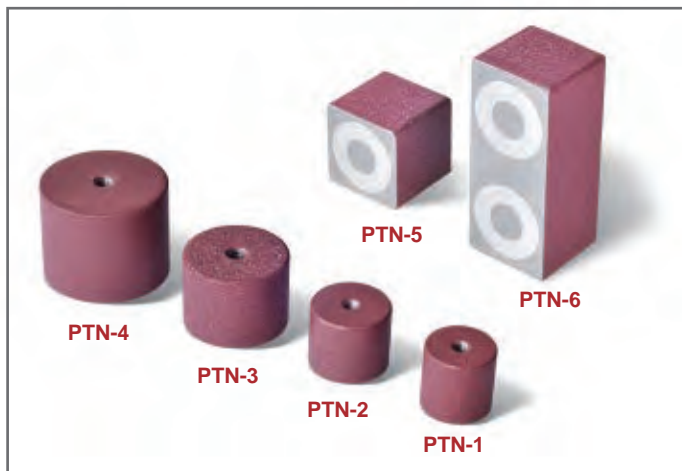

● Holding magnet

Use:

Can be used to hold down drawings, rules and paper patterns.
Can be incorporated in press dies.
Can hold workpieces during wire cutting.

Features:

- For specifications, OD tolerance, plating, painting and peripheral knurling, are available for selection according to applications.
- When tapped holes are made on the back, they can be used in various applications.



Model	Holding Power	Dimensions	Tapped Hole	Magnet type
PTN-1	150 N	Φ26(1.02) x 25(0.98)	M6 x 1.0	NdFeB
PTN-2	180 N	Φ30(1.18) x 26(1.02)	M6 x 1.0	NdFeB
PTN-3	300 N	Φ40(1.57) x 30(1.18)	M8 x 1.25	NdFeB
PTN-4	500 N	Φ50(1.97) x 40(1.57)	M8 x 1.25	NdFeB
PTN-5	140 N	26(1.02) x 26(1.02) x 25(0.98)	N/A	NdFeB
PTN-6	200 N	26(1.02) x 60(2.36) x 25(0.98)	M6 x 1.0	NdFeB

Model	Tapped Hole
PTN-7	M6 x 1.0
PTN-8	M8 x 1.25

Unit: mm(in)

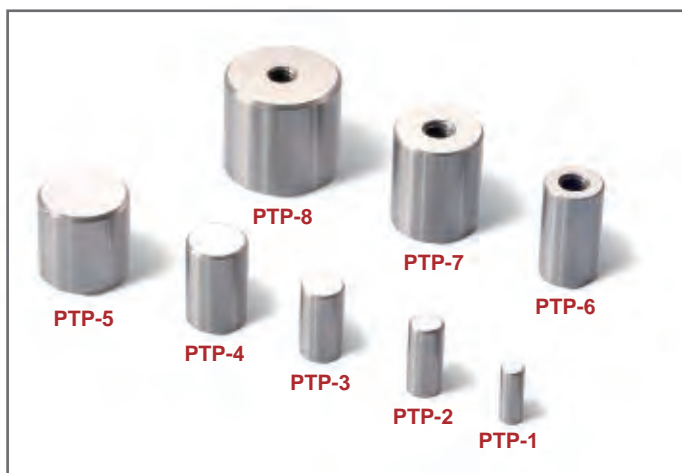

● Holding magnet

Use:

Can be used to hold down drawings, rules and paper patterns.
Can be incorporated in press dies.
Can hold workpieces during wire cutting.

Features:

- For specifications, OD tolerance, plating, painting and peripheral knurling, are available for selection according to applications.
- When tapped holes are made on the back, they can be used in various applications.

Model	Holding Power	Dimensions	Tapped Hole	Magnet type
PTP-1	1.8 N	Φ5(0.20) x 13(0.51)	-	Alnico
PTP-2	4.0 N	Φ7(0.26) x 13(0.51)	-	Alnico
PTP-3	8.0 N	Φ10(0.39) x 15(0.59)	-	Alnico
PTP-4	20 N	Φ15(0.59) x 15(0.59)	-	Alnico
PTP-5	40 N	Φ20(0.79) x 15(0.59)	-	Alnico
PTP-6	8.0 N	Φ10(0.39) x 18(0.71)	M5 x 0.8	Alnico
PTP-7	20 N	Φ15(0.59) x 18(0.71)	M5 x 0.8	Alnico
PTP-8	40 N	Φ20(0.79) x 18(0.71)	M5 x 0.8	Alnico

Unit: mm(in)

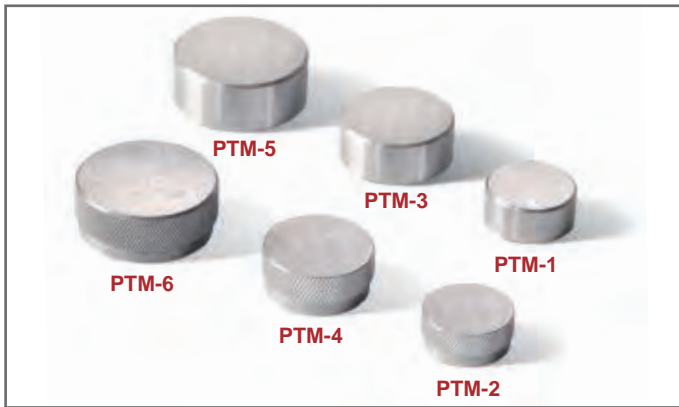

● Holding magnet

Use:

Can be used to hold down drawings, rules and paper patterns.
Can be incorporated in press dies.
Can hold workpieces during wire cutting.

Features:

- For specifications, OD tolerance, plating, painting and peripheral knurling, are available for selection according to applications.

Example of Application

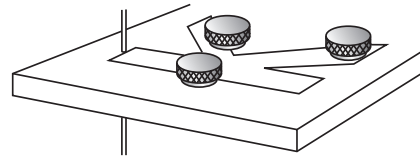

These holding magnets can be used to hold pieces cut out by wire cutting to prevent them from moving or falling from the securing area.

Model	Holding Power	Dimensions	Knurl	Magnet type
PTM-1	30 N	φ10(0.39) x 8(0.31)	NO	SmCo
PTM-2	30 N	φ10(0.39) x 8(0.31)	YES	SmCo
PTM-3	50 N	φ18(0.71) x 8(0.31)	NO	SmCo
PTM-4	50 N	φ18(0.71) x 8(0.31)	YES	SmCo
PTM-5	90 N	φ25(0.98) x 10(0.39)	NO	SmCo
PTM-6	90 N	φ25(0.98) x 10(0.39)	YES	SmCo

Unit: mm(in)

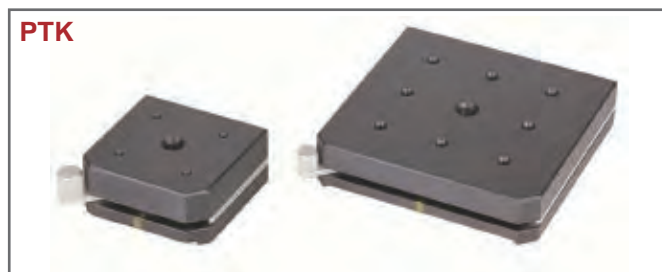

● Thin type magnetic holder

Use:

For installation in apparatus, hold, position

Features:

- Thin and powerful magnetic force
- Material alnico 500

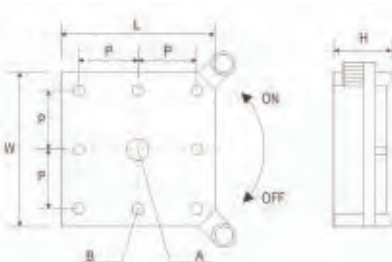

Model	Diameter (D)	W	L	H	A	B	P	Net Weight
PTK-1	17 (0.67)	16 (0.63)	16 (0.63)	16 (0.63)	18 N	4 (0.16)	18 N	26 g / 0.04 lb
PTK-2	21 (0.83)	19 (0.75)	19 (0.75)	19 (0.75)	28 N	5 (0.20)	28 N	50 g / 0.07 lb
PTK-3	27 (1.06)	25 (0.98)	25 (0.98)	25 (0.98)	65 N	6 (0.24)	65 N	110 g / 0.07 lb
PTK-4	35 (1.38)	30 (1.18)	30 (1.18)	30 (1.18)	115 N	9 (0.35)	115 N	215 g / 0.07 lb

Unit: mm(in)



● Thin type magnetic holder

Use:

For installation in apparatus, hold, position

Features:

- Thin and powerful magnetic force
- Material alnico 500

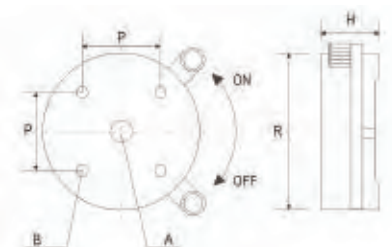

Model	Diameter (D)	W	L	H	A	B	P	Net Weight
PTL-1	17 (0.67)	16 (0.63)	16 (0.63)	16 (0.63)	18 N	4 (0.16)	18 N	26 g / 0.04 lb
PTL-2	21 (0.83)	19 (0.75)	19 (0.75)	19 (0.75)	28 N	5 (0.20)	28 N	50 g / 0.07 lb

Unit: mm(in)

MB / MSA



• Magnetic base

Use:
Using as a clamping base

- Features:**
- Can be used as a register base or a measuring base
 - Additional magnetic surface at the rear

Model	Holding Power	Length	Width	Height	Tapped Hole	Net Weight
MB-17	170 N	30 (1.18)	30 (1.18)	30 (1.18)	M5 x 0.8 x 5	0.2 kg / 0.44 lb
MB-40	400 N	36 (1.42)	30 (1.18)	35 (1.38)	M5 x 0.8	0.2 kg / 0.44 lb
MB-60	600 N	55 (2.17)	50 (1.97)	73 (2.87)	M8 x 1.25 x 7	1.2 kg / 2.64 lb
MB-80	800 N	60 (2.28)	50 (1.97)	55 (2.17)	M8 x 1.25 x 7	1 kg / 2.2 lb
MB-100	1000 N	73 (2.87)	50 (1.97)	55 (2.17)	M8 x 1.25 x 7	1.3 kg / 2.86 lb
MB-130	1300 N	117 (4.61)	50 (1.97)	55 (2.17)	M8 x 1.25 x 7	2 kg / 4.4 lb
MB-150	1500 N	120 (4.72)	60 (2.36)	52 (2.05)	M8 x 1.25 x 7	2.5 kg / 5.5 lb

Unit: mm(in)

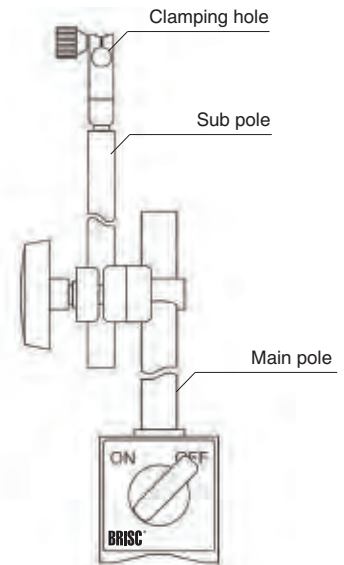

• Magnetic stand

Use:
Holding a measuring device such as dial gauge

- Features:**
- Improved precision and efficiency
 - Can be held on vertical, upsidedown or round bar surface

Model	Clamping Force	Base Dimension	Dia. (Main Pole)	Length (Main Pole)	Dia. (Sub Pole)	Length (Sub Pole)	Dia. (Clamp hole)	Net Weight
MSA-A	800 N	60 (2.28) x 50 (1.97) x 55 (2.17)	12 (0.47)	180 (7.09)	10 (0.39)	205 (8.07)	8 (0.31)	1.6 kg / 3.53 lb
MSA-B	800 N	60 (2.28) x 50 (1.97) x 55 (2.17)	14 (0.55)	205 (8.07)	12 (0.47)	210 (8.27)	8 (0.31)	1.7 kg / 3.75 lb
MSA-C	1000 N	73 (2.87) x 50 (1.97) x 55 (2.17)	16 (0.63)	250 (9.84)	16 (0.63)	245 (9.65)	8 (0.31)	2.5 kg / 5.51 lb
MSA-D	1300 N	117 (4.61) x 50 (1.97) x 55 (2.17)	18 (0.71)	350 (13.78)	16 (0.63)	245 (9.65)	8 (0.31)	3.4 kg / 7.50 lb

Unit: mm(in)



MSB-A



MSB-B



MSB-C



MSB-D



MSB-E

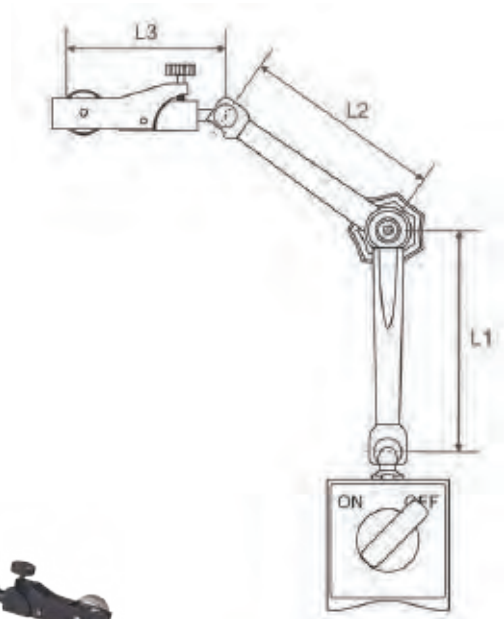

• Magnetic stand

Use:
Holding a measuring device such as dial gauge

- Features:**
- Mechanical universal arm
 - Fine adjustment high precision clamp

Model	Clamping Force	Base Dimension	Arm Length	L1	L2	L3	Dia. (Clamp hole)	Net Weight
MSB-A	300 N	35 (1.38) x 30 (1.18) x 35 (1.38)	158 (6.22)	56 (2.2)	51 (2.01)	17 (0.67)	8 (0.31)	0.4 kg / 0.88 lb
MSB-B	300 N	35 (1.38) x 30 (1.18) x 35 (1.38)	205 (8.07)	56 (2.2)	51 (2.01)	73 (2.87)	8 (0.31)	0.4 kg / 0.88 lb
MSB-C	800 N	60 (2.28) x 50 (1.97) x 55 (2.17)	310 (12.2)	110 (4.33)	101 (3.98)	73 (2.87)	8 (0.31)	1.4 kg / 3.09 lb
MSB-D	1000 N	73 (2.87) x 50 (1.97) x 55 (2.17)	385 (15.16)	147 (5.79)	130 (5.12)	76 (2.99)	8 (0.31)	1.8 kg / 3.97 lb
MSB-E	1300 N	117 (4.61) x 50 (1.97) x 55 (2.17)	635 (25)	285 (11.22)	225 (8.86)	76 (2.99)	8 (0.31)	5.0 kg / 11 lb

Unit: mm(in)



COMPLETE METALWORKING SOLUTIONS

(800) 991-4225

www.ahbinc.com

ISO Certified

customerservice@ahbinc.com

BRISC[®]

© 1998-2018, SOPH GmbH, Hamburg, Germany

Copyright

All text, drawings, photos and product illustrations are subject to copyright and are the property of SOPH GmbH

Technical Changes

The data and illustrations in this catalogue are not binding and only provide an approximate description. We reserve the right to make changes to the product delivered compared with the data and illustrations in this catalogue, e.g. in respect of technical data, design, fittings, material and external appearance.

SOPH GmbH

Hermann-Buck-Weg 8, 22309 Hamburg

Tel: +49-40-609 46 36 70 Fax: +49-40-609 46 36 79

SOPH Inc

195 South Alloy Dr. Fenton MI 48430

Tel: +1-810-750-1120 Fax: +1-810-750-1141

SOPH Ltd

No. 6, 555 Jin Du Xi Road, Shanghai 201612

Tel: +86-21-67649948 Fax: +86-21-67649973

www.soph-magnet.com