

30 Years

SCHUNK

Grippers

1983 – 2013

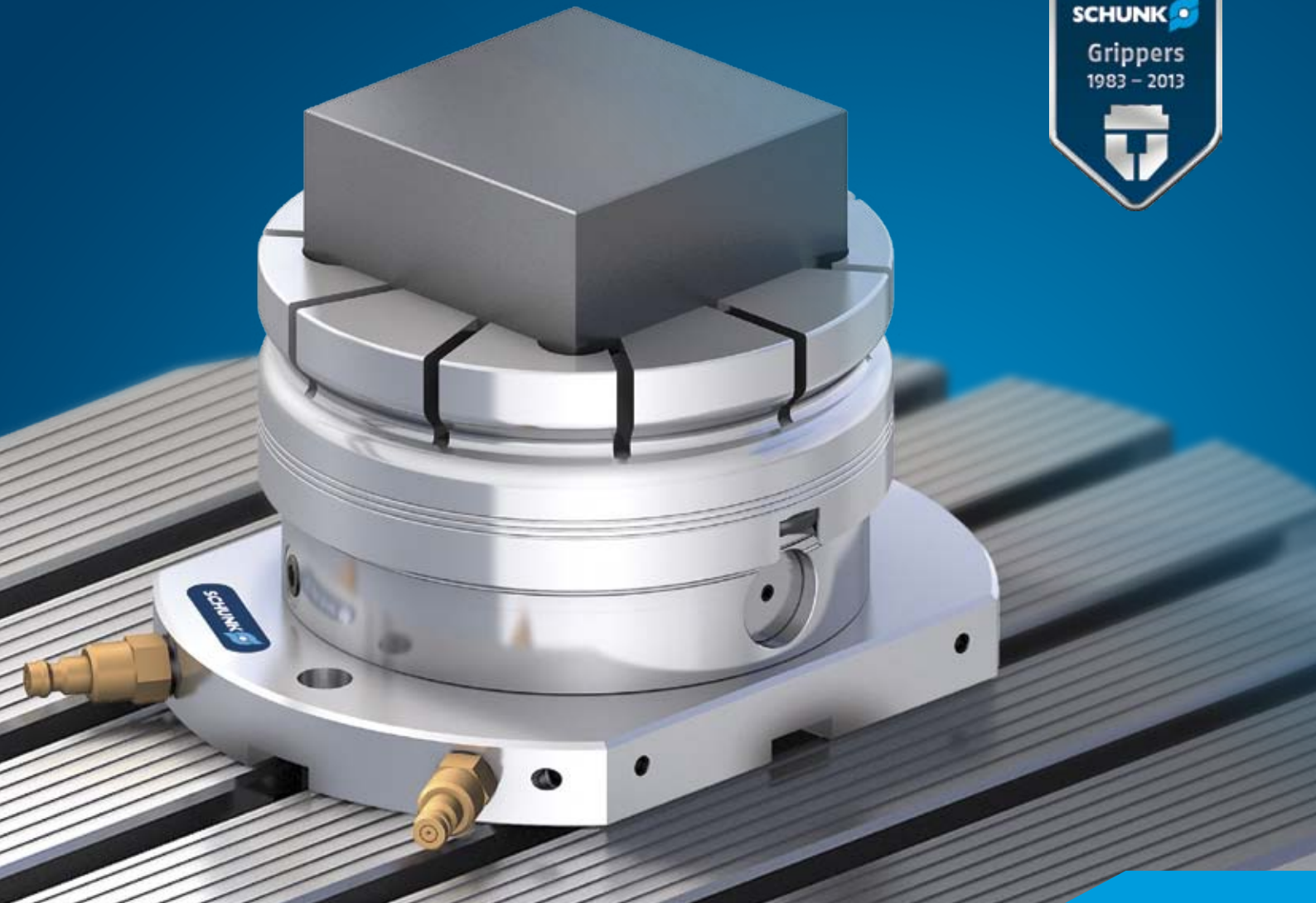

Superior Clamping and Gripping

SCHUNK 

VERO-S

SPM Fixture Membrane

Perfect adaptation to
workpiece contour

100 % Adaptation to your workpiece



Automated handling



Lathe

Automated handling



Machining center

Automatic machine loading



Mobile gripping systems

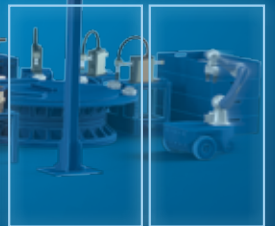

Modular assembly automation

Superior clamping and gripping – it's time to make use of your machine's full potential.

With superior components, we awake reserves where you would never expect to find them. In your machine. SCHUNK SYNERGY – the perfectly harmonized interplay of clamping technology and gripping systems makes our customers a champion of productivity.

The VERO-S SPM plus 138 fixture membrane: Direct clamping of workpieces for stationary use

Enormous savings in set-up costs for your production!

With the VERO-S SPM plus 138 fixture membrane we offer you a multi-functional and economical solution which is also suitable for complex clamping tasks. High clamping forces due to the high pull-in forces of the VERO-S SPM enable perfect adaptation to the contour of your workpiece – simple, safe and reliable!

Applications

- Especially suitable for thin workpieces
- For clamping filigree workpieces
- For maximum dimension and shape accuracy
- For light to medium machining



Maximum ratio of clamping diameter to workpiece height (projecting length): 1 : 1
Recommended clamping depth: approx. 4 mm

Your advantages

- Active pull-down function
- Multiple uses in almost all stationary machining tasks
- Suitable for all workpiece geometries
- For all types of material



Our promise of performance. Your benefit.

Lighter	Base body made of aluminum
More sustainable	Multiple uses due to readjustable clamping contour
More powerful	High clamping force also for cylindrical clamping contours
Safer	Active pull-down function for optimal holding of the workpiece
More comprehensive	Suitable for the standard modules VERO-S NSE plus 138-V1 with torque pin and VERO-S NSL plus 150-VT (turbo function required)

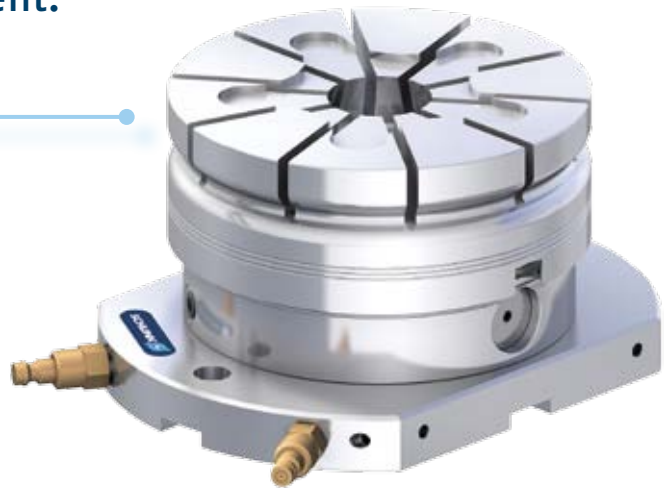

Technical data

Scope of delivery	ID number	Max. clamping force	Workpiece size Ø* max/min	Clamping stroke	Weight
Fixture membrane with indexing pin and SPC clamping pin	0471158	50 kN	125 - 36	0.5 mm	1.5 kg
Fixture membrane with indexing pin as torque pin	0471159	50 kN	125 - 36	0.5 mm	1.5 kg

*Workpiece shape freely selectable

Dimensions

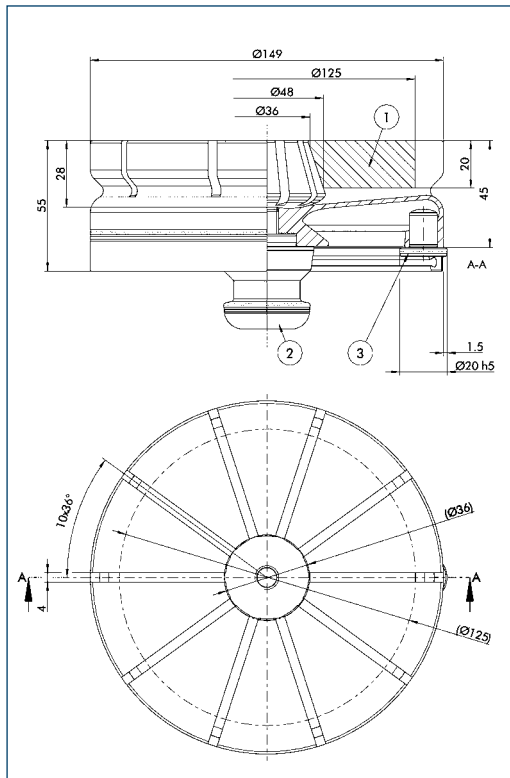

Centering function creates an optimal machining situation

Centering on the ground module's outer diameter and in the precision torque slot ensures the perfect repeatable positioning accuracy of the fixture membrane on the clamping module.



Workpieces can be reliably machined by direct clamping:



1 The fixture membrane is individually adapted to the workpiece contour. The adjusting ring and the fixture membrane blank are inserted into the unlocked quick-change pallet system.



2 The air supply of the turbo function is connected and afterwards disconnected with a short pressure pulse.

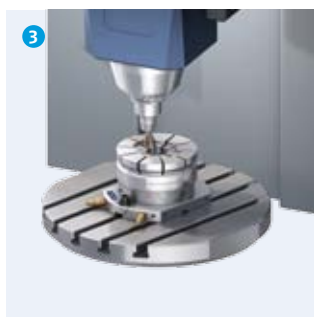

3 While the fixture membrane is preclamped by the adjusting ring, the precise workpiece contour is milled out of the fixture membrane blank.



4 The unlocking connection is actuated.



5 This means that the fixture membrane and adjusting ring can be removed from the quick-change pallet system.



6 The prepared fixture membrane is placed onto the quick-change pallet system without adjusting ring for the machining of the workpiece.



7 The workpiece is inserted precisely into the deepened workpiece geometry.



8 Before machining, the air connection is to be disconnected from the unlocking connection. The pull-in force can be increased by switching on the turbo function.

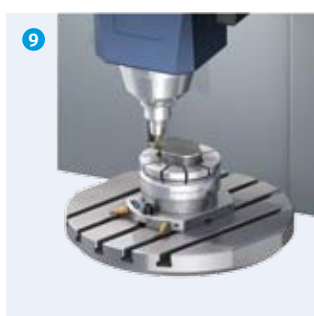

9 The workpiece is now clamped and can be machined.





10 When the operation is complete, the air connection can be disconnected, and the workpiece can be removed.

Accessories

You can find our accessories for using the VERO-S SPM and for optimal machining results here.

	Description	ID number
	Clamping pin SPC 40RF	0471153
	Adjusting ring	8508288
	VERO-S NSL plus 150-VT	0471047

	Description	ID number
	Indexing pin IXB VI NSE PLUS	0471980
	Screw	9937667

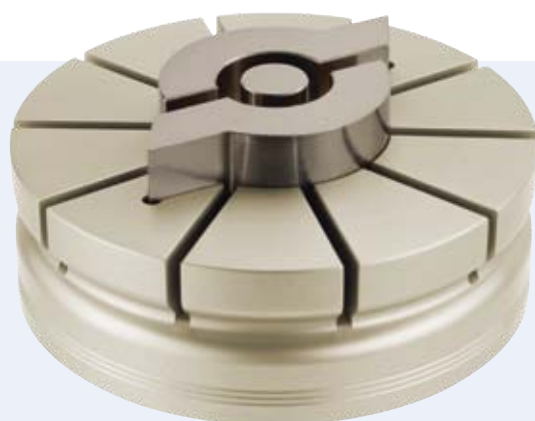

VERO-S SPM fixture membrane

With the VERO-S SPM, SCHUNK, the competence leader for clamping technology and gripping systems, offers a clamping device that perfectly adapts to the workpiece contour.

J. Lehmann

Jens Lehmann,
German goalkeeper legend,
brand ambassador of SCHUNK,
the family-owned company
since 2012



For further information visit:
www.schunk.com/qr/vero-s/en