

SOWA

TOOLING
YOUR
WORLD.

AHB

TOOLING & MACHINERY

COMPLETE METALWORKING SOLUTIONS

(800) 991-4225

www.ahbinc.com

ISO Certified

customerservice@ahbinc.com

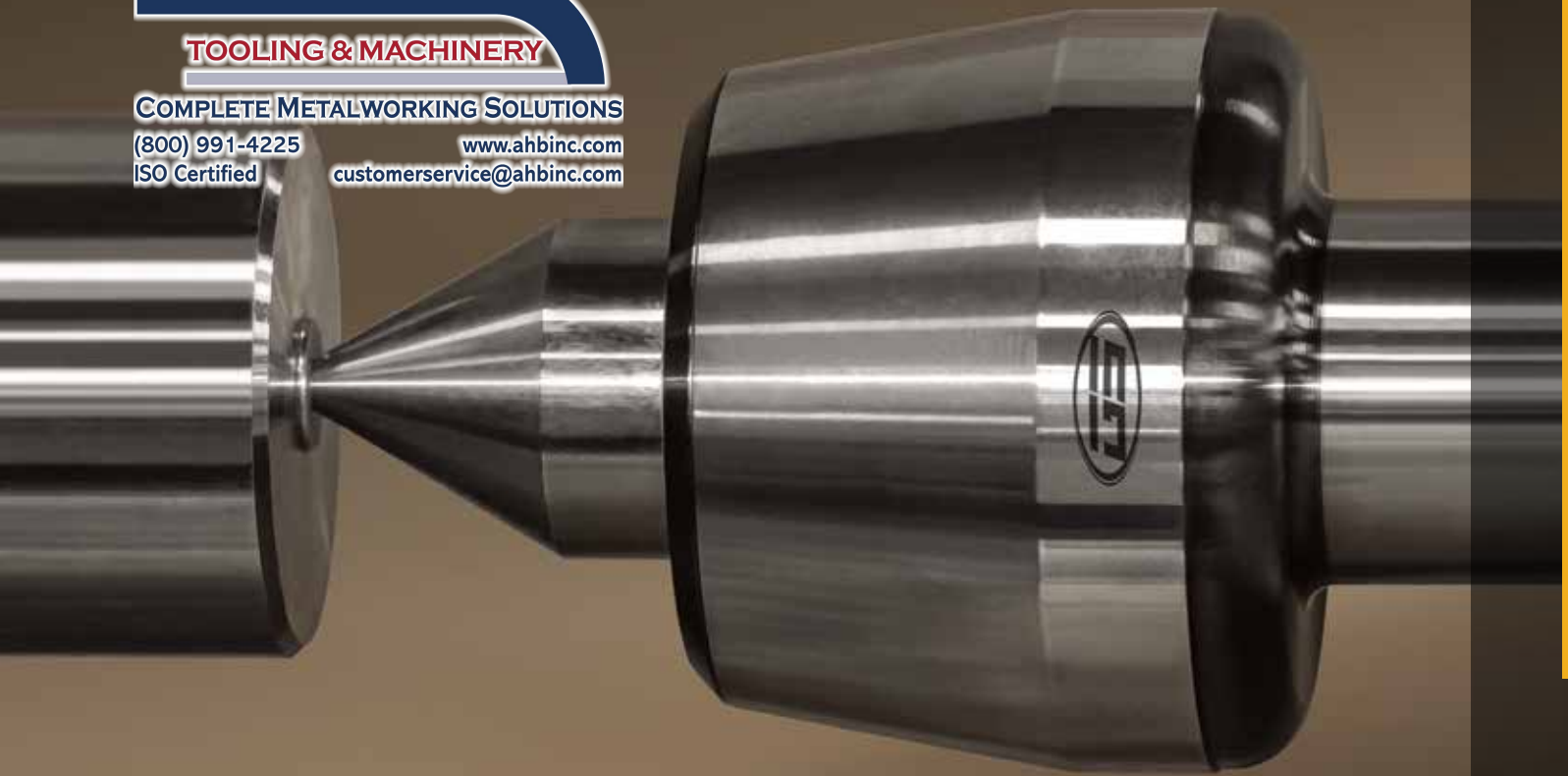

High Performance Live Centers



GS Live Centers	3-8
Skoda Live Centers	9-13
STM Live Centers	10
Skoda Live Center Sets	14
STM Carbide Tipped Dead Lathe Centers	14



Superior performance tool holding and workholding solutions when speed and accuracy matter most.

GS Tooling is an industry leader in precision tooling where high-performance and stringent quality standards are paramount. Tool your World with GS Tooling End Mill Holders, Collet Chucks & Collets, Retention Knobs, Vises & Workholding, Live Centers, Angle Heads, Carbide End Mills and more!



Tool Holding



Angle Heads & Driven Tooling



Cutting Tools



Vises & Workholding





High Performance Live Centers

As a leading manufacturer of rotary tooling and machine vises, GS Tooling is known for providing the highest quality tooling, manufactured to the industry's tightest specifications. Our new GS Live Centers are no exception, if you haven't tried them now is the time!

PRECISION • QUALITY • PERFORMANCE



✓ Each GS Live Center uses either a 3, 4, or the incredible 5-bearing system. Each bearing system has been individually and specifically designed for the applications in which that live center is meant to be used. This specificity of design provides superior performance and tool life across the entire GS line of centers.

✓ An additional special coating process is applied to the lip seal contact area. This coating offers a higher sealing ability and reduces rotational friction, both contributing to longer tool life.

✓ If roller bearings are used at high temperatures, the hardness of the bearing steel decreases. Consequently, the basic load rating, which depends on the physical properties of the material, also decreases. GS Live Centers are designed to prevent excessive heat. Live center temperatures are controlled even when rotating at maximum RPM.

✓ Every single center has passed at least four different accuracy tests to ensure our customers the highest quality available in the market today.

✓ GS Tooling is committed to delivering outstanding value to our customers. In fact, we are so confident with the quality and performance of these live centers that we are offering a **30-day money back guarantee** against manufacturers defects.

CNC High Speed Live Centers — Standard Point



Features

- Accuracy guaranteed to 0.003mm TIR (0.0001")
- Excellent for CNC and conventional machines
- Heat treated point to 60±2HRC
- High performance lip seal and deflected shaft design protects bearing space from ingress by dust and coolant
- 4-Bearing System: a double row angular contact bearing, a radial ball bearing, and a rear needle roller bearing combine to provide excellent rigidity and high precision point concentricity
- Heat treated drop-forged body (50±2HRC) for extra strength, rigidity, and long life
- Shaft borehole for easy dismounting

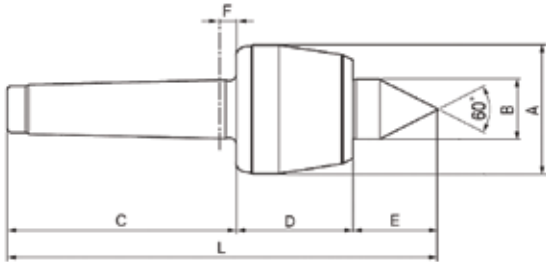

- MT2-3
- MT4
- MT5

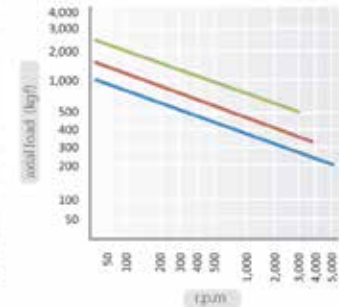
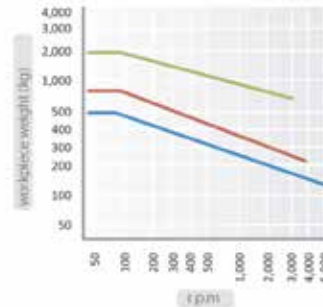

Dimensions

MT	A (mm)	B (mm)	C (mm)	D (mm)	E (mm)	F (mm)	L (mm)	Workpiece Weight	Max RPM	Weight	Max Runout	Code No.
2	50	25	68	43.5	29.5	6	141	500 kg	5,000	0.7 kg	0.003mm	311011
3	50	25	85	43.5	29.5	6	158	500 kg	5,000	0.8 kg	0.003mm	311012
4	69	32	108	55	40	8	203	800 kg	3,800	1.85 kg	0.003mm	311013
5	88	40	136	70	50.5	8	256.3	2,000 kg	3,000	4.2 kg	0.003mm	311014
6	105	50	189	81.5	57.5	10	328	3,500 kg	2,800	8.7 kg	0.005mm	311015

CNC High Speed Live Centers — Extended A Type Point



Features

- Accuracy guaranteed to 0.003mm TIR (0.0001")
- Excellent for CNC and conventional machines
- Specially shaped elongated centre point improves tool clearance and machining flexibility for cramped area work
- Heat treated point to 60±2HRC
- High performance lip seal and deflected shaft design protects bearing space from ingress by dust and coolant
- 4-Bearing System: a double row angular contact bearing, a radial ball bearing, and a rear needle roller bearing combine to provide excellent rigidity and high precision point concentricity
- Heat treated body for extra strength, rigidity, and long life

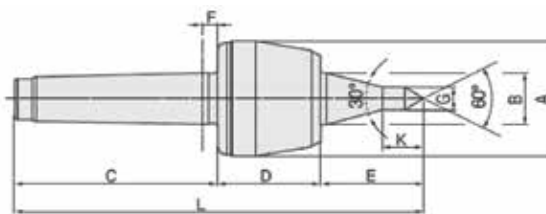

- MT2-3
- MT4
- MT5

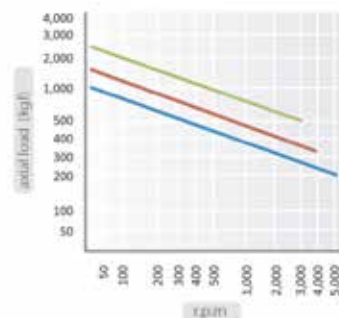
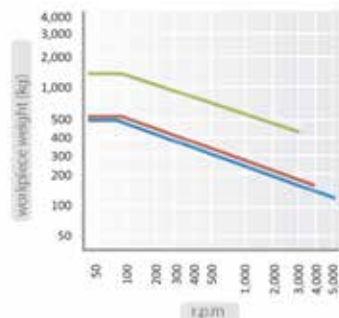

Dimensions

MT	A (mm)	B (mm)	C (mm)	D (mm)	E (mm)	F (mm)	G (mm)	K (mm)	L (mm)	Workpiece Weight	Max RPM	Weight	Max Runout	Code No.
2	50	25	68	43.5	50	6	10	19	161.5	500 kg	5,000	0.7 kg	0.003mm	311016
3	50	25	85	43.5	50	6	10	19	178.5	500 kg	5,000	0.8 kg	0.003mm	311017
4	69	32	108	55	63.5	8	12.5	23.5	226.5	550 kg	3,800	1.9 kg	0.003mm	311018
5	88	40	136	70	80	8	12.5	23.5	286	1,500 kg	3,000	4.4 kg	0.003mm	311019

High Performance Live Centers

Features

- Accuracy guaranteed to 0.003mm TIR (0.0001")
- Excellent for light/medium duty work on conventional lathe machines
- Heat treated point to 60±2HRC
- Slim diameter improves tool clearance
- Triple Bearing System: 2 radial ball bearings and a thrust bearing provide good overall load ratings and improved performance
- Rear bearing is sealed, protecting the assembly from coolant and chips
- Live centre made of wear-resistant, drop-forged tool steel

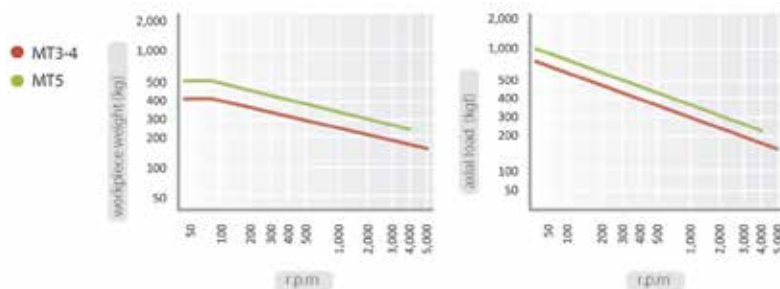
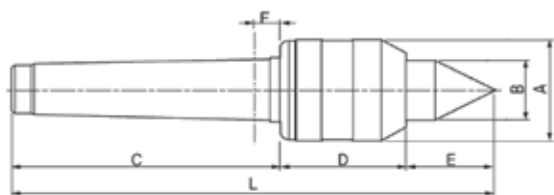

Dimensions

MT	A (mm)	B (mm)	C (mm)	D (mm)	E (mm)	F (mm)	L (mm)	Workpiece Weight	Max Axial Load	Max RPM	Weight	Max Runout	Code No.
3	44.5	25	85	44	32.5	5.3	161.5	400 kg	600 kg	5,000	1 kg	0.003mm	311024
4	44.5	25	108	44	32.5	5.3	184.5	400 kg	600 kg	5,000	1.2 kg	0.003mm	311025
5	63	28	136	58	35	6.3	229	500 kg	750 kg	4,000	2.8 kg	0.003mm	311031

High Speed Live Centers

Features

- Accuracy guaranteed to 0.002mm TIR (0.0001")
- Excellent for grinders, CNC machines, and high speed light duty machining
- Heat treated point to 60±2HRC
- High RPM (up to 6,000)
- Five Bearing System: A double row angular contact bearing, two single row angular contact bearings, and a rear needle roller bearing combine to provide improved runout, greater stability, longer tool life, and superior performance
- Anti-friction seal for coolant deflection and high speed
- Heat treated body for extra strength, rigidity, and long life
- Shaft borehole for easy, efficient dismounting
- Drop forged body (50±2HRC) for long life

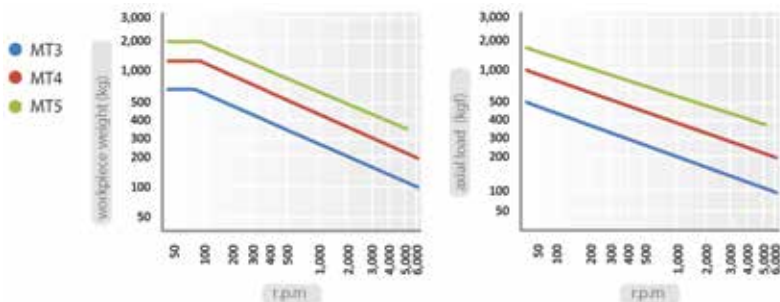
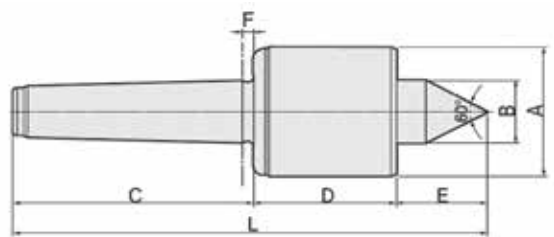

Dimensions

MT	A (mm)	B (mm)	C (mm)	D (mm)	E (mm)	F (mm)	L (mm)	Workpiece Weight	Max RPM	Weight	Max Runout	Code No.
3	50	20	85	58	23	4.5	166	750 kg	6,000	1.9 kg	0.002mm	311034
4	66	30	108	71	35	5.3	214	1,300 kg	6,000	2.4 kg	0.002mm	311026
5	80	35	136	76	38	6.3	250	2,000 kg	5,000	5.3 kg	0.002mm	311027

High Speed Live Centers — Extended A Type Point



Features

- Accuracy guaranteed to 0.002mm TIR (0.0001")
- Excellent for grinders, CNC machines, and high speed light duty machining
- Heat treated point to 60±2HRC
- High RPM (up to 6,000)
- Five Bearing System: A double row angular contact bearing, two single row angular contact bearings, and a rear needle roller bearing combine to provide improved runout, greater stability, longer tool life, and superior performance
- Anti-friction seal for coolant deflection and high speed
- Heat treated body for extra strength, rigidity, and long life
- Shaft borehole for easy, efficient dismounting
- Drop forged body (50±2HRC) for long life

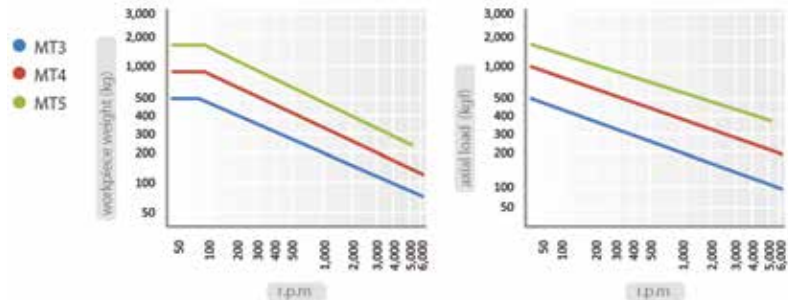
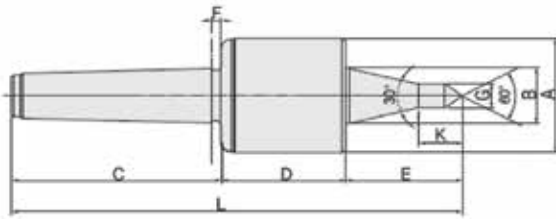

Dimensions

MT	A (mm)	B (mm)	C (mm)	D (mm)	E (mm)	F (mm)	G (mm)	K (mm)	L (mm)	Workpiece Weight	Max RPM	Weight	Max Runout	Code No.
3	50	20	85	58	37	4.5	10	15	180	500 kg	6,000	1.9 kg	0.002mm	311028
4	66	31	107	71	63.5	5.3	12.5	23	241.5	900 kg	6,000	2.4 kg	0.002mm	311029
5	80	35	136	78	70	6.3	12.5	23.5	284	1,700 kg	5,000	5.3 kg	0.002mm	311030

60° Bull Head Live Centers — Extended A Type Point



Features

- Accuracy guaranteed to 0.003mm TIR (0.0001")
- Heat treated point to 60±2HRC
- For pipe work, tube work, and parts with extra-large centre holes
- 4-Bearing System: double row angular contact bearing, thrust ball bearing, and a radial ball bearing combine to provide excellent rigidity and high precision point concentricity
- Used both as a centering taper for hollow bodies and as a centre for machining standard workpieces
- Elongated centre point is specially shaped for improved tool clearance

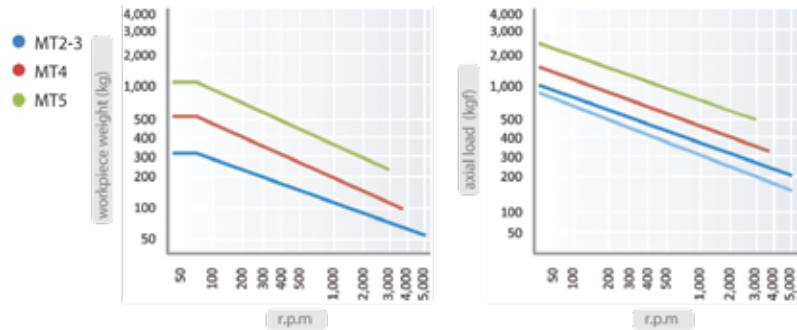
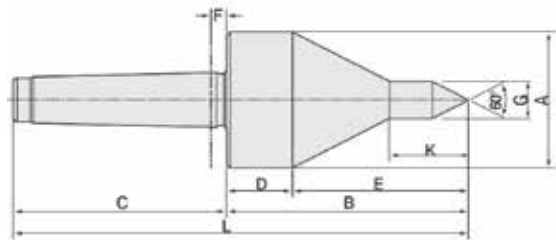

Dimensions

MT	A (mm)	B (mm)	C (mm)	D (mm)	E (mm)	F (mm)	G (mm)	K (mm)	L (mm)	Workpiece Weight	Max RPM	Weight	Max Runout	Code No.
3	56	86	85	28.9	57.1	6	12	19	171	320 kg	5,000	1.0 kg	0.003mm	311032
4	78	103.5	108	26.3	77.2	8	16	23.5	211.5	560 kg	3,800	2.3 kg	0.003mm	311023
5	96	140	136	41.6	98.4	8	19	30	276	1,200 kg	3,000	5.0 kg	0.003mm	311033

80° Bull Nose Live Centers — Standard Point

Features

- Accuracy guaranteed to 0.003mm TIR (0.0001")
- Excellent for heavy duty lathe applications
- Heat treated point to 60±2HRC
- For pipe work, tube work, and part with extra-large centre holes
- Triple Bearing System: a taper roller bearing, thrust bearing, and a high-precision radial ball bearing combine to provide excellent rigidity and superior performance
- The design prevents ingress of coolant and chips
- Shaft borehole for easy, efficient dismounting
- Drop forged shaft (50±2HRC)

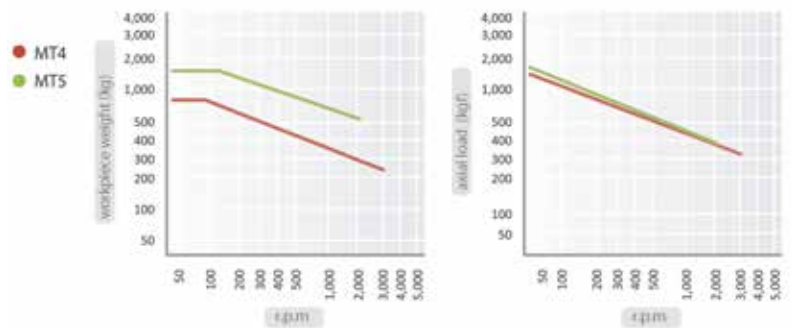
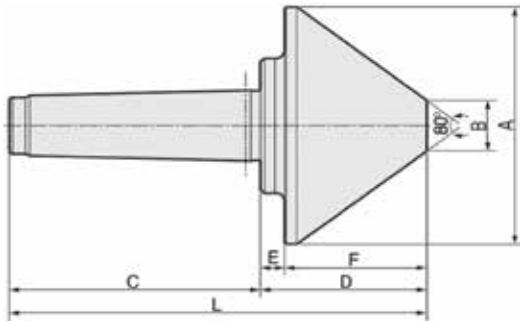

Dimensions

MT	A (mm)	B (mm)	C (mm)	D (mm)	E (mm)	F (mm)	L (mm)	Workpiece Weight	Max RPM	Weight	Max Runout	Code No.
4	125	29	108	77	13	64	185	800 kg	3,000	3.9 kg	0.003mm	311036
5	150	32	136	90	13	77	226	1,600 kg	2,000	6.9 kg	0.003mm	311035



Indexable External Turning Toolholders

Requires fewer tool changes than solid tools in high level metalworking.

Visit www.SowaTool.com for more information.

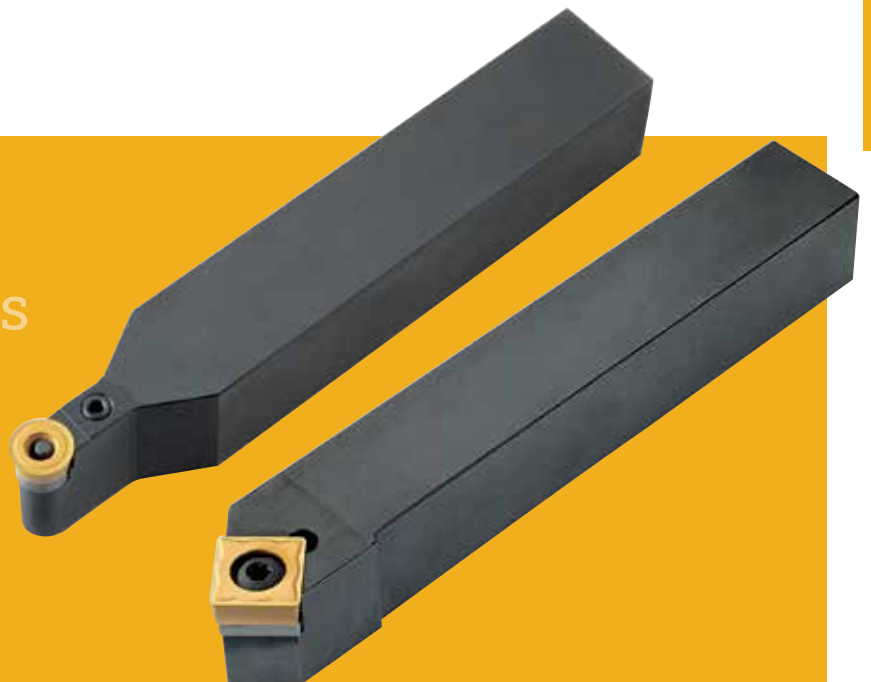



Interchangeable Points Live Centers

Features

Each holder comes with the 60° H insert. Other inserts available individually (see below)

- Accuracy for centre inner diameter guaranteed to 0.003mm
- Accuracy after point locking guaranteed to 0.005mm
- Excellent for individual production of various workpieces through different insert shafts
- Heat treated point to 60±2HRC
- 4 types of standard point are available
- 4-Bearing System: a double row angular contact bearing, a radial ball bearing, and a rear needle roller bearing combine to provide excellent rigidity and superior performance
- Because of the insert shafts the allowed workpiece weight is limited
- Mounting taper of point is 1/10
- Drop forged (50±2HRC) body
- Shaft borehole for easy, efficient dismounting

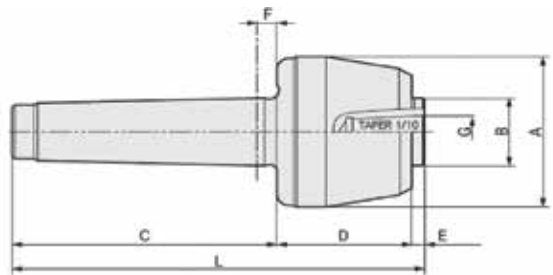

- MT3
- MT4
- MT5

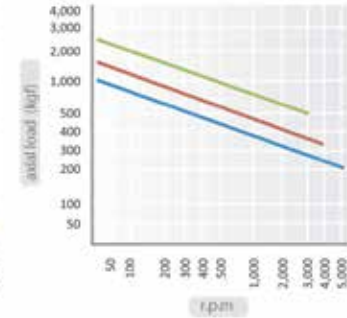
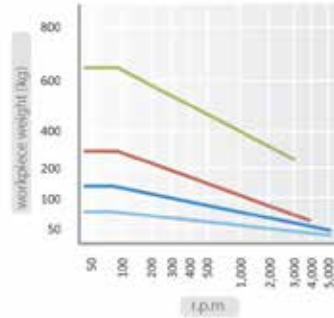

Dimensions

MT	A (mm)	B (mm)	C (mm)	D (mm)	E (mm)	F (mm)	G (mm)	L (mm)	Workpiece Weight	Max RPM	Weight	Max Runout	Code No.
3	50	25	85	43.5	5	6	12	133.5	150 kg	5,000	0.8 kg	0.005mm	311020
4	69	32	108	55	5	8	15	168	250 kg	3,800	1.7 kg	0.005mm	311021
5	88	40	136	70	6	8	22	212	650 kg	3,000	3.9 kg	0.005mm	311022

Interchangeable Points



Features

Each holder comes with the 60° H insert and a point lever.

Other inserts available individually (see below)

- Accuracy for centre inner diameter guaranteed to 0.003mm
- Accuracy after point locking guaranteed to 0.005mm
- Mounting taper of point is 1/10



MT	Inserts	a (mm)	b (mm)	c (mm)	d (mm)	Code No.
3	H	24	51.5	20	-	311037
	K	18	54	25	8	311038
	L	45	51	17.5	25	311039
	M	22	60	18	6.5	311040
	Disassembling Tool					311068
4	H	28	61.5	23.5	-	311041
	K	26	73	36	12	311042
	L	55	61.5	21.5	30.2	311043
	M	40	55	35	16.5	311044
	Disassembling Tool					311069
5	H	38	78	32	-	311045
	K	32	90	46	13	311046
	L	70	74	20	40	311047
	M	52	65	45	25.4	311048
	Disassembling Tool					311070

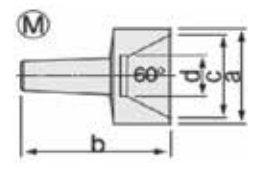
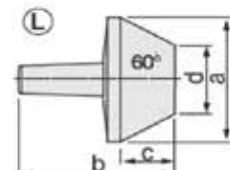
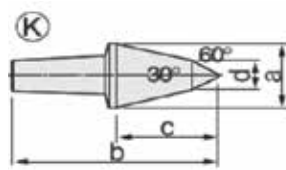
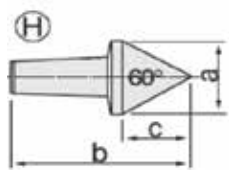



High value production grade live centers, points, parts and kits.

The most popular live centers in the USA!



- ✓ The technical construction of Skoda products connects a high level of useful properties with aesthetic and elegant design.
- ✓ Maximum robustness and wear resistance of the MORSE taper.
- ✓ Self-grip MORSE taper (MT) and Metric (Me) series.
- ✓ Long-term constant accuracy of the tolerance thanks to unique option for fine and precise clearance adjustment.
- ✓ Easy maintenance of the bearings using lithium grease.
- ✓ Special static seal ensuring dustproof and waterproof tightness.
- ✓ Optimal slenderness ratio guarantees maximum rigidity and long-term functionality.
- ✓ Top professional service, a wide range of products available, and environmentally friendly packaging guarantees the maximum satisfaction of our all customers.

High Performance Live Centers

Skoda Heavy Duty Silver Line Live Centers — CSN 243324/CSN 243324M



Features

- The rotating spindle is extended right through the tapered shank
- Two specially designed adjustable needle-roller bearings carry all radial loads
- A heavy duty ball thrust bearing takes all axial thrust
- Complete protection of bearings from the ingress of coolant, dirt or swarf is provided by the built-in oil-seal, which also prevents loss of lubricant



Morse Taper	Center				Maximum RPM	Maximum Weight of Work Piece	SKODA Code No.	STM Code No.
	Point Angle	Body Dia. (in)	Body Dia. (in)	Body Length (in)				
1	60°	5/8	1-3/8	4-3/8	6,000	200 lb	310105	-
2	60°	7/8	1-1/2	5	6,000	750 lb	310110	320110
3	60°	1-1/8	1-7/8	6-1/4	5,000	880 lb	310115	320115
4	60°	1-1/2	2-3/16	7-1/2	4,000	2860 lb	310120	320120
5	60°	1-3/4	2-3/4	9-1/2	3,500	4400 lb	310125	320125
6	60°	2-3/8	3-1/2	12-3/4	2,500	8800 lb	310130	-

PARTS FOR HEAVY DUTY LIVE CENTRES

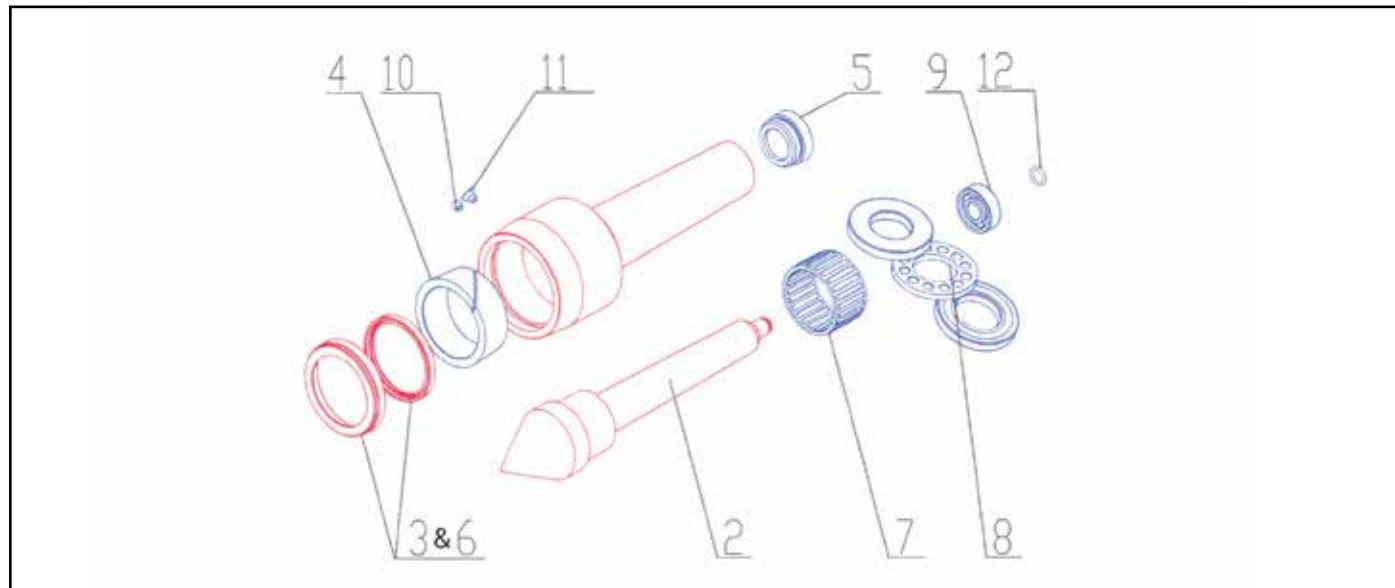

Parts For Heavy Duty Live Centres



Morse Taper	2-Point Code No.	3 & 6-Ring & Seal Code No.	4-Sleeve Code No.	5-End Plug Code No.	7-Roller Bearing Code No.	8-Thrust Bearing Code No.	9-Ball Bearing Code No.	10-Set Screw Code No.	11-Slot Screw Code No.	12-Ring Code No.
2	310205M	310211	310215	310220	310230	310235	310240	310245	310250	310255
3	310305M	310311	310315	310320	310330	310335	310340	310345	310350	310355
4	310405M	310411	310415	310420	310430	310435	310440	310445	310450	310455
5	310505M	310511	310515	310520	310530	310535	310540	310545	310550	310555
6	310605M	310611	310615	310620	310630	310635	310640	310645	310650	310655

Skoda Extra Heavy Duty Live Centers — CSN 243325



For clamping of heavy workpieces at lathes.

- The rigid structure and seating of the turning part is characterized by long service life
- The model EXTRA is commonly used for work at grinding machines
- Centers with the apex angle of 60° for reduction of deformations of the machine (tailstock, bed, headstock) from axial clamping forces
- The live centers are provided with shanks according to DIN 228 and ISO 296 (without clamping thread)

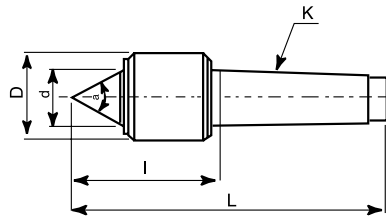

Morse Taper	D (in.)	d (in.)	a	l (in.)	L (in.)	Maximum RPM	Load (lb)	Weight (lb)	Code No.
4	3.14	1.58	60°	4.10	7.85	3,200	3300	5	310920
5	3.54	1.65	60°	5.60	9.48	2,700	5500	9	310925
6	4.92	2.16	60°	6.42	13.38	1,900	11000	27	310930
7	5.70	2.56	60°	7.80	15.25	1,600	17600	45	310935

SPARE PARTS FOR EXTRA HEAVY DUTY LIVE CENTERS

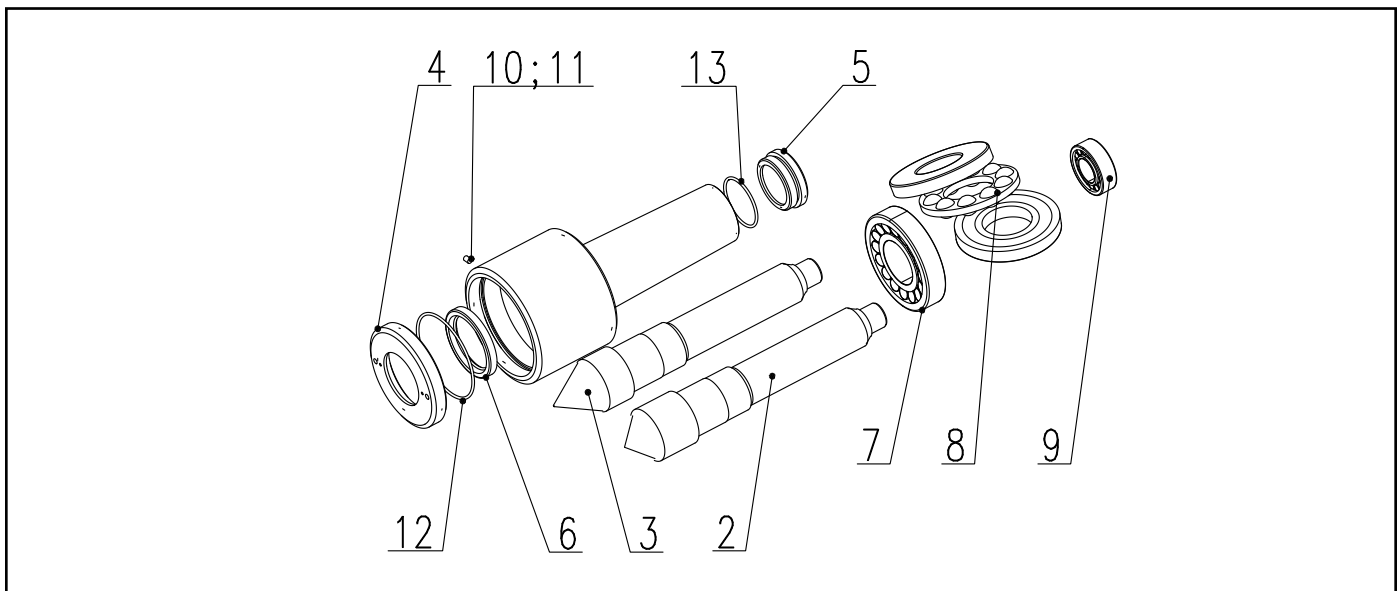

Spare Parts For Extra Heavy Duty Live Centers



Parts No.	Description	Code No.
MT 4-02	90° Point	310802
4-03	60° Point	310803
4-04	Ring	310804
4-05	End Plug	310805
4-06	Sealing	310806
4-07	Roller Bearing	310807
4-08	Thrust Bearing	310808
4-09	Radial Bearing	310809
4-10	Lock Screw	310810
4-11	Packing Piece	310811
4-12	Packing Ring	310812
4-13	Packing Ring	310813
MT 5-02	90° Point	310816
5-03	60° Point	310817
5-04	Ring	310818
5-05	End Plug	310819
5-06	Sealing	310820
5-07	Roller Bearing	310821
5-08	Thrust Bearing	310822
5-09	Radial Bearing	310823
5-10	Lock Screw	310824
5-11	Packing Piece	310825
5-12	Packing Ring	310826
5-13	Packing Ring	310827

Spare Parts For Extra Heavy Duty Live Centers



Parts No.	Description	Code No.
MT 6-02	90° Point	310830
6-03	60° Point	310831
6-04	Ring	310832
6-05	End Plug	310833
6-06	Sealing	310834
6-07	Roller Bearing	310835
6-08	Thrust Bearing	310836
6-09	Radial Bearing	310837
6-10	Lock Screw	310838
6-11	Packing Piece	310839
6-12	Packing Ring	310840
6-13	Packing Ring	310841

High Performance Live Centers

Skoda Precision CNC Silver Line Live Centers — CSN 243327-II



- The centres are intended for NC lathes. Their face parts are formed to allow easy access of the tool to the workpiece, which is an advantage with workpieces of complex shapes
- A special ring is used to set the radial clearance of the centre. It also prevents cutting lubricant from leaking into the centre bearing space, and so extends the centre's operational life
- Spindle-like point extends into shank where it is supported by a needle bearing, increasing rigidity, reducing point deflection and dampening vibration

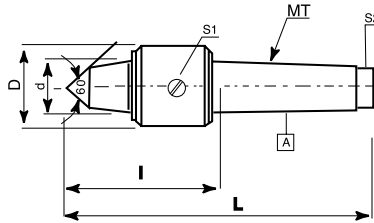

Morse Taper	D (in.)	d (in.)	L (in.)	l (in.)	Maximum RPM	Load (lb)	Code No.
2	1.5	0.695	5.25	2.65	6,000	594	310010
3	1.85	0.750	6.75	3.50	5,000	704	310015
4	2.20	1.125	8.15	3.95	4,000	2200	310020
5	3.10	1.375	10.50	4.85	3,500	3520	310025

SPARE PARTS FOR CNC LIVE CENTERS

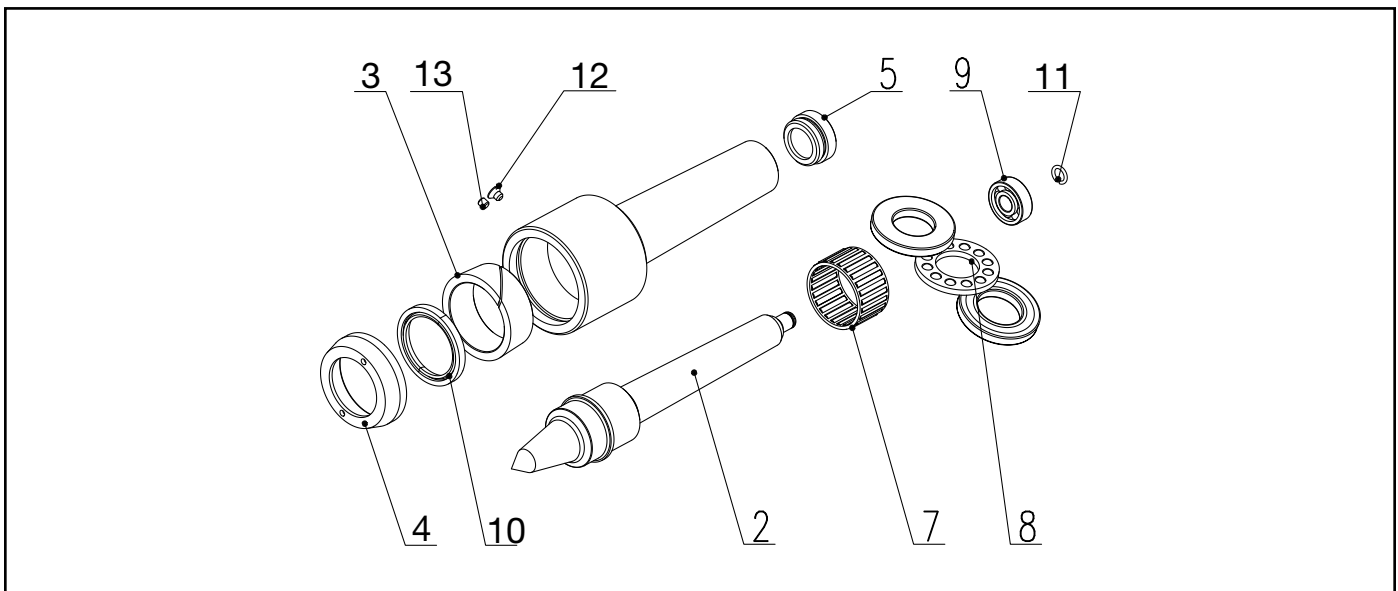

Spare Parts For CNC Live Centers



Parts No.	Description	Code No.
MT 2-02	Point	310855
2-03	Ring	310857
2-04	Set Ring	310856
2-05	End Plug	310858
2-07	Needle Bearing	310860
2-08	Thrust Bearing	310861
2-09	Radial Bearing	310862
2-10	Packing Piece	310859
2-11	Snap Ring	310865
2-12	Countersink Screw	310863
2-13	Lock Screw	310864
MT 3-02	Point	310869
3-03	Ring	310871
3-04	Set Ring	310870
3-05	End Plug	310872
3-07	Needle Bearing	310874
3-08	Thrust Bearing	310875
3-09	Radial Bearing	310876
3-10	Packing Piece	310873
3-11	Snap Ring	310879
3-12	Countersink Screw	310877
3-13	Lock Screw	310878

Spare Parts For CNC Live Centers



Parts No.	Description	Code No.
MT 4-02	Point	310882
4-03	Ring	310884
4-04	Set Ring	310883
4-05	End Plug	310885
4-07	Needle Bearing	310887
4-08	Thrust Bearing	310888
4-09	Radial Bearing	310889
4-10	Packing Piece	310886
4-11	Snap Ring	310892
4-12	Countersink Screw	310890
4-13	Lock Screw	310891
MT 5-02	Point	310895
5-03	Ring	310897
5-04	Set Ring	310896
5-05	End Plug	310898
5-07	Needle Bearing	310900
5-08	Thrust Bearing	310901
5-09	Radial Bearing	310902
5-10	Packing Piece	310899
5-11	Snap Ring	310905
5-12	Countersink Screw	310903
5-13	Lock Screw	310904

Skoda Extended Point Silver Line Live Centers — CSN 243328



- Designed to keep dust, chips and coolant from coming inside the bearings
- Hardened and ground to 61-65 Rockwell
- Concentricity within 0.0002"

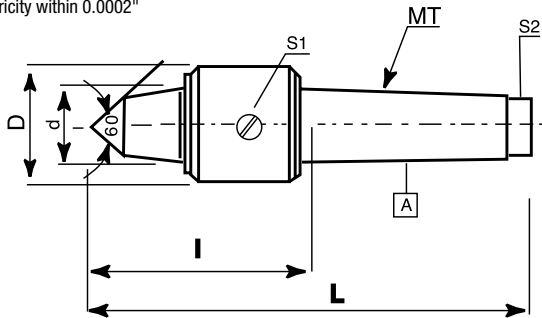

Morse Taper	D (in.)	d (in.)	L (in.)	I (in.)	Maximum RPM	Load (lb)	Weight (lb)	Point Angle	Code No.
2	1.417	0.866	5.059	2.560	6,000	594	0.79	60°	310160
3	1.850	1.181	6.575	3.386	5,000	704	1.85	60°	310165
4	2.165	1.378	8.169	4.094	4,000	2200	3.19	60°	310170
5	2.736	1.772	10.197	5.078	3,500	3960	7.04	60°	310175
6	3.504	2.362	13.425	6.319	2,500	7040	17.05	60°	310180

Extended Points



Morse Taper	Code No.
2	310200
3	310300
4	310400
5	310500
6	310600



Skoda Heavy Duty Bull Nose Silver Line Live Centers — CSN 243319



Designed to hold pipe and hollow work. Pipe head can be used as an all-round centre for light work. Two matched angular contact bearings preloaded at the factory. This achieves good thrust and radial capacities. Bearings are protected by a combination steel shield and neoprene seal.

- Accuracy: ± 0.0001 "

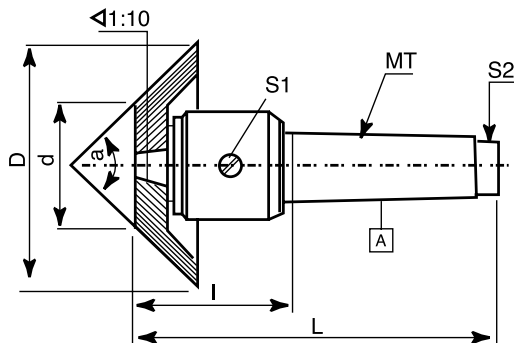

Morse Taper	a	D (in.)	d (in.)	L (in.)	I (in.)	Maximum RPM	Load (lb)	Weight (lb)	Code No.
3	60°	3.150	1.378	6.380	3.189	5,000	880	4.62	310140
4	60°	4.527	1.732	7.637	3.622	4,000	2860	9.68	310145
5	60°	5.314	1.811	9.449	4.331	3,500	4400	17.60	310150
6	60°	6.693	2.520	12.125	4.961	2,500	8800	51.70	310155

High Performance Live Centers

Skoda Silver Line Live Center Sets — CSN 243326



Features

- The rotating spindle is extended right through the tapered shank
- Two specially designed adjustable needle-roller bearings carry all radial loads
- A heavy duty ball thrust bearing takes all axial thrust
- Complete protection of bearings from the ingress of coolant, dirt or swarf is provided by the built-in oil-seal, which also prevents loss of lubricant



Morse Taper	All		A	B-G	A		B		C		D			E			F		G	Code No.
	d	l	L	L	D	D1	D	D1	D	D1	D	D1	D2	D	D1	D2	D	D1	D	
3	0.590	0.984	1.968	1.771	0.787	0.019	1.417	0.236	2.480	1.299	1.417	1.102	0.472	1.771	1.496	0.866	0.787	0.098	0.984	310705
4	0.784	1.181	2.362	2.086	0.984	0.019	1.771	0.393	2.755	1.378	1.771	1.456	0.669	2.480	2.086	1.181	0.984	0.196	1.259	310710
5	0.984	1.496	2.874	2.559	1.259	0.039	2.204	0.551	3.149	1.496	2.204	1.732	0.787	2.775	2.362	1.417	1.259	0.196	1.771	310715
6	1.181	1.811	3.543	3.149	1.417	0.039	2.755	0.708	3.937	1.968	2.755	2.283	0.950	3.937	3.464	2.126	1.417	0.315	2.204	310720

Morse Taper	Max Load (lb)
3	880
4	2860
5	4400
6	8800

Maximum weight of workpiece is independent of the individual point being used.

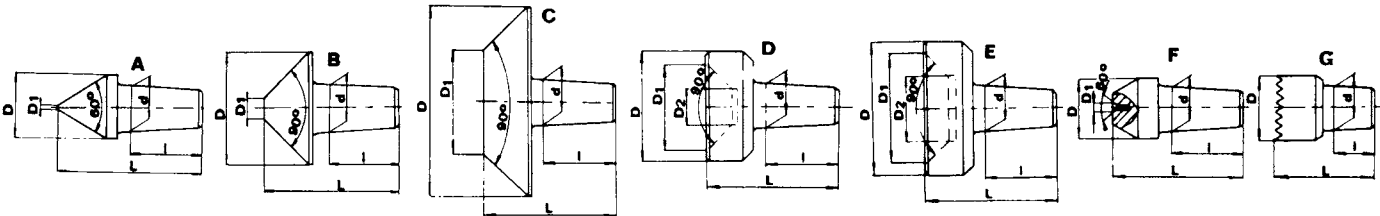

Parts For Skoda Live Center Sets



Morse Taper	Part A Code No.	Part B Code No.	Part C Code No.	Part D Code No.	Part E Code No.	Part F Code No.	Part G Code No.
3	310724	310726	310728	310730	310732	310734	310736
4	310744	310746	310748	310750	310752	310754	310756
5	310764	310766	310768	310770	310772	310774	310776
6	310784	310786	310788	310790	310792	310794	310796

Additional Items For Skoda Live Center Sets



Morse Taper	Live Center Only Code No.	Internal Point Code No.	Wooden Case Code No.	Drift Key Code No.
3	310722	310723	310738	310740
4	310742	310743	310758	310760
5	310762	310763	310778	310780
6	310782	310783	310798	310800

STM Carbide Tipped Dead Lathe Center



With Morse Taper. Included angle is 60°. They are precision made, hardened and ground to closest tolerances.



Morse Taper	Length	Code No.
1	3-3/16	420905
2	3-15/16	420910
3	4-15/16	420915
4	6-5/16	420920
5	7-7/8	420925
6	11	420930

Sowa Tool has been serving the metalworking industry since 1960.

Your world is full of challenges and worrying about having the right tools for the job should not be one of them. With a three-generation legacy of family-style customer service, Sowa Tool & Machine has been trusted by manufacturers and distributors throughout North America to supply some of the industry's best metalworking solutions since 1960.

Our mission has been and continues to be to provide the broadest range of metalworking solutions in the industry. We accomplish this through the continuous development of our family of brands that include items within the Tool Holding, Workholding, Measuring & Inspecting, and Cutting Tool categories. This allows you to secure all these solutions from one place, reducing your total number of purchase orders and consolidating your freight charges in this increasingly expensive market.

Our wide array of metalworking products come in stock with same-day shipping if ordered before 3:00 pm EST. Our customer service team is just a call or click away, available to offer technical help or source hard-to-find products. Over the decades we've fine-tuned the balance between inventory, pricing and customer service, and can help you select precisely what you need to get the job done right. Our manufactured products are designed to meet the highest quality standards or provide the best price on the market, sometimes both!

26,000+

INDUSTRIAL PRODUCTS

6

INDUSTRY BRANDS

1960

YEAR FOUNDED

5

WAREHOUSES

90+

ASSOCIATES

23,000+

STOCKED SKU'S IN THE USA



**Depend on us to tool your world and deliver
the competitive edge your business needs to stay ahead!**

Welcome to the **Sowa** family!



Superior performance tool holding and workholding solutions when speed and accuracy matter most.

ASIMETO

High-performance precision measuring and inspecting solutions.



High-performance cutting tools including end mills, drills, taps and indexables.

SKODA

High Value production grade live centers.

narex

Exclusive line of value boring heads.



A wide product range of economic tooling for general purpose applications.



With this line-up, Sowa Tool is uniquely qualified to serve all your needs under one roof. Ask us how Sowa can tool your world and provide the competitive edge for your business.

Distributed by:



COMPLETE METALWORKING SOLUTIONS

(800) 991-4225

www.ahbinc.com

ISO Certified

customerservice@ahbinc.com

Sowa
TOOLING YOUR WORLD.

Sowa Tool & Machine Co. Ltd.

Canadian Head Office
500 Manitou Drive, Kitchener, ON, N2C 1L3

North Carolina Office
101-137 Overhill Drive, Mooresville, NC 28117