



GS160 6" Precision
Milling Machine Vise
327320



Get the Most Out of **Your Workspace**

With the **GS100G** 4" Precision Milling Machine Vise, a smaller version of the 6" Vise we know you love.

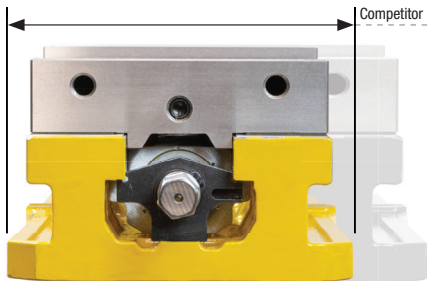

NARROW BODY STYLE*
to allow more vises on a machine table.
*compared to the competition

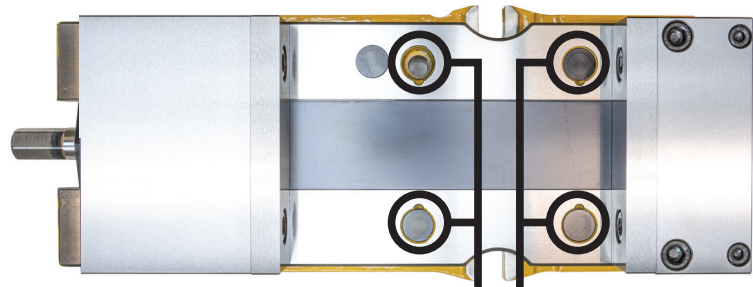

HOLD DOWN BOLT HOLES
allow for easy side by side mounting of multiple vises on a table.

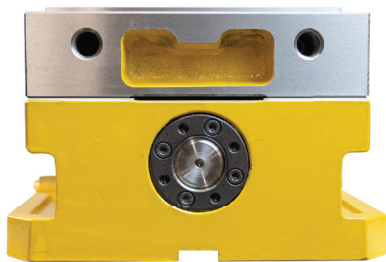

A larger, more durable
BEARING PACK
that does not protrude from
the end of the vise body.

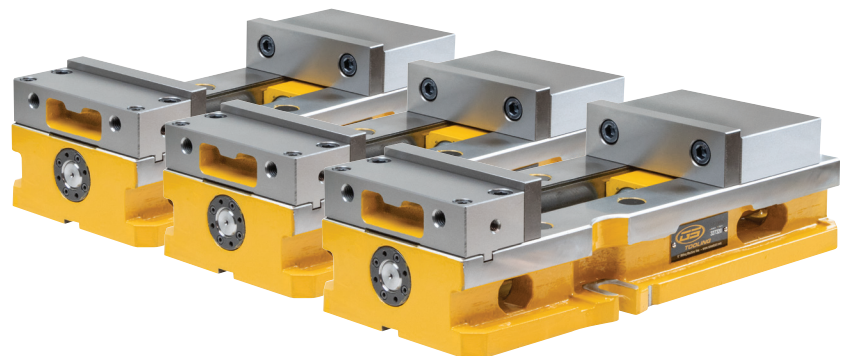

MATCHED BED HEIGHTS within $\pm 0.0005"$
allow for multiple vises to be easily used in parallel.



GS100G

4" Precision Milling Machine Vise

This Vise is packed with industry-leading workholding features

- Larger, more durable **bearing pack** engineered to deliver a highly stable workholding system that is stronger under pressure.
- A new brush seal design **keeps debris from penetrating the nut** due to a more efficient **chip evacuation system** through both the body and ends of the vise, while not compromising on the strength of the body.
- Spherical Segment creates an **all directional alignment** and **reduces jaw lift** of the movable jaw, while the 4-bolt design of the fixed jaw enables **stable clamping**.
- **Reduced stress on body** as a result of the pull-type design features also includes a **spindle nut that does not protrude** past the end of the body during clamping.

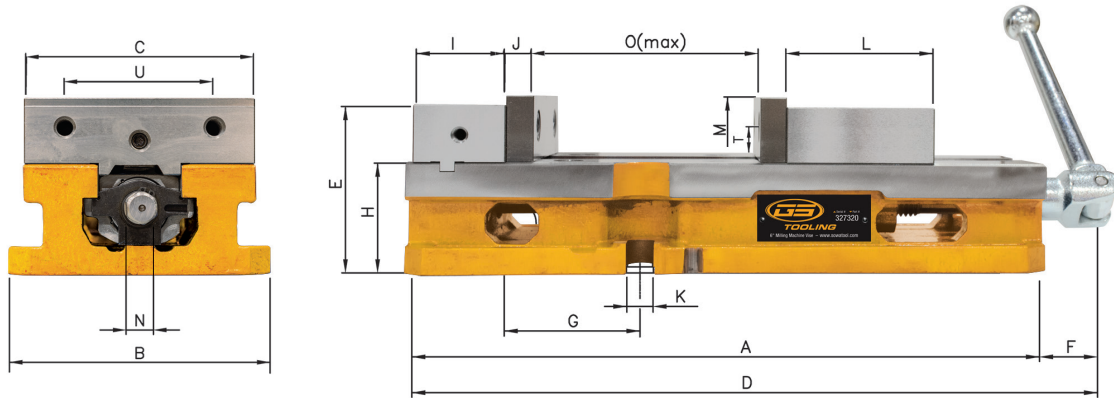

Compare the new GS100G with the GS160G

Model	A	B	C	D	E	F	G	H	I	J	K	L	M	N	O	T	U	Weight	Code No.
GS100G	12.5	5	4	13.7	3.37	1.14	2.56	2.25	1.75	0.55	0.5	3.1	1.24	0.55	6.5	0.69	2.5	30.86lbs	327319
GS160G	16.8	7.3	6	18.4	4.37	1.54	3.56	2.875	2.31	0.725	0.725	4	1.75	0.75	9.1	0.94	3.875	68.34lbs	327320

Selection of other GS Tooling matched machine vises

Matched With **GS675**

Code No: 327320

GS160G
6" Precision Milling Machine Vise
2.875" Matched Bed Height

Matched With **GS160G**

Code No: 327275M

GS675
6" Precision Milling Machine Vise
2.875" Matched Bed Height

Code No: 382620

GSV60
6" Versatile Machine Vise
3.189" Matched Bed Height

Code No: 327300

GS810
8" Precision Milling Machine Vise
3.310" Matched Bed Height



Sowa Tool & Machine Co. Ltd.

Canadian Headquarters
500 Manitou Drive, Kitchener, ON, N2C 1L3
US Headquarters
101-137 Overhill Drive, Mooresville, NC 28117