



ENGINEERED WORKHOLDING MECHANISMS



TOOLING & MACHINERY

COMPLETE METALWORKING SOLUTIONS
(800) 991-4225 www.ahbinc.com
ISO Certified customerservice@ahbinc.com



EXPERIENCE AND CAPABILITY



Speedgrip Chuck has been designing and building precision workholding products for customers for over 70 years. Although we have often been copied, we have not been equaled in the experience or capability we offer our customers in addressing their needs. Whether you are looking for standard I.D. collet workholding components or special design and build Collet Chucks, Diaphragm Chucks, Mechanical or Hydraulic Arbors, Speedgrip is prepared to meet your requirements. Our sales and engineering departments look forward to reviewing your machining or inspection applications and providing you with quality Workholding Solutions.



QUALITY

Speedgrip manufactures workholding mechanisms and components to meet customers exacting specifications. After manufacture and during assembly our Quality Control Inspectors evaluate every part and chucking mechanism to insure that customers receive products that meet their workholding needs every time.

SPECIALS, DESIGN AND BUILD WORKHOLDING

Whether your parts require workholding for high volume production or they are just special enough that they exceed our standards capability, Speedgrip's sales and engineering departments have the experience to provide you with the solutions to your workholding applications.



SALES

Our Sales Estimators are not just people who calculate costs and take orders, they are project managers involved from your request for quotation to final assembly and shipping. All our estimators have hands-on shop manufacturing experience. They use this experience in reviewing operations and processes to insure the best possible pricing and expedient delivery of your workholding assemblies.



ENGINEERING

With a full time staff of experienced Engineers and state-of-the-art 3D CAD design hardware and software to support and enhance their capabilities, Speedgrip is able to offer customers complete engineering and design service. No matter what the challenge, a speciality part, modified standard or special design chuck, Speedgrip Engineers are directly accessible to assist customers in creating Workholding Solutions to meet their needs.



MANUFACTURING

Speedgrip is a 50,000 Sq. Ft. facility fully staffed and equipped to provide customers with workholding products on site and on time. We maintain a large inventory of raw material in stock sizes to 17' and full machining capability of turning, milling and grinding up to 48' diameter. With this size, inventory, and capabilities, no jobs are delayed for lack of material or production capacity.

TABLE OF CONTENTS



6



8



10



12



15



16

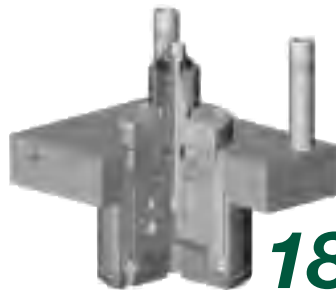

18



20

Process Capability and Applications 5

Internal Diameter Workholding 6

External Diameter Collet Workholding 8

Diaphragm Chucks
Internal and External Gripping 10

Clamp and Finger Chucks 12

Expanding Mandrels for Machining, Balancing, and Inspection 14

Gear Application Workholding 16

Fixturing Applications 18

Special Use Workholding 20

Thru-Hole Collet Chuck 22

Collet Actuators 23

Air and Hydraulic Rotating Cylinders 24-25

Standard Chucking Components 26

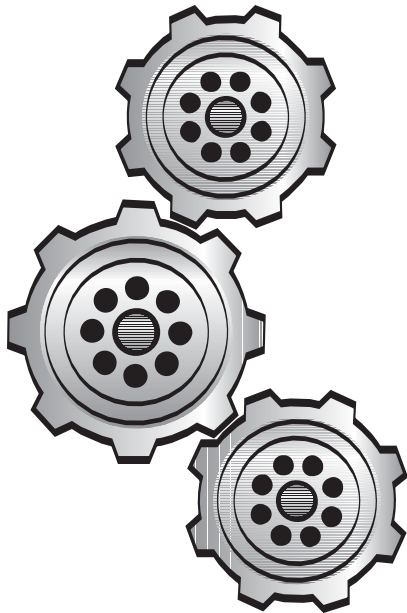
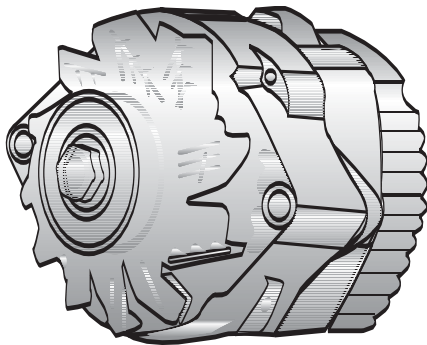
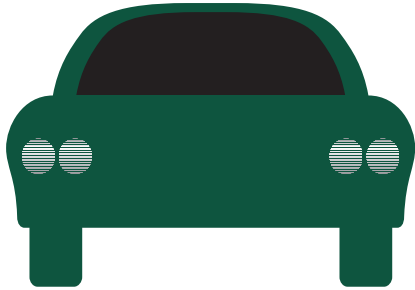
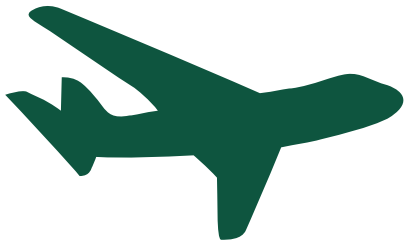

Capable of addressing your process needs—

Whether you are a small, medium, or large **Production Facility**, a **Product Manufacturer**, an **Outsource Supplier**, an **Original Equipment Manufacturer** or a **Machine Tool Distributor**, Speedgrip Chuck can service your needs.

Engineered workholding solutions for:

- **Turning • Milling • Grinding • Hobbing**
- **Shaving • Welding • Balancing • Inspection**
- **Fixture Building • Your Unique Use**

Experienced in Industry's Applications

Automotive Industry:

Dealing with Engine, Transmission, or Drive Train components...

Aerospace Industry:

Parts relating to Turbines, Landing Gear, or Armament components...

Electric Motor Industry:

Holding tools for Strators, Armatures, or Housings...

Gear Industry, Manufacturing Gears, Inspecting Gears, or Manufacturing and Selling Machines for those tasks...

Whatever your needs, Speedgrip Chuck offers you the experience and expertise to provide you with

Engineered Workholding Solutions

INTERNAL DIAMETER WORKHOLDING

Speedgrip experience in internal workholding goes far beyond our line of standard product components. Engineered workholding mechanisms using single, double taper, split from one end and other collet configurations can be designed and engineered to meet your workholding needs.

SELF CONTAINED DOUBLE COLLET

Automotive disk brake rotors require machining accuracy to establish good concentricity, squareness and satisfactory "in-balance" condition. All too often, rotors are totally machined and the remaining non-functional cast surfaces cause balance problems.

A leading rotor manufacturer instituted an inspection process for the balance problem. Out-of-balance castings could be recognized prior to the machining operation by using a self-contained double collet chuck.

The chuck, produced by Speedgrip, grips one end of the rotor for certain checks and then can be reversed and gripped on the opposite end. This end-to-end check then allows determination of casting quality prior to the investment of expensive machining operations.



REF# B-15961



REF# B-22184

Split From One End Collet Chuck used by an automotive engine manufacturer in a gear cutting operation.



REF# B-32367

Self Contained Balancing Chuck Assembly with alternately slotted collet produced for a balancing machine manufacturer dealing with a transmission component balancing operation.



REF# B-33006

Split From One End Collet Chuck used by an "off road" automotive equipment manufacturer in a face milling operation of frame castings.



REF# 7A-EWM

Dual I.D. Collet Chuck Part Ejector w/ Stir-Around feature for drawbar actuation. This chuck was designed for manufacture of a part requiring holding on two bores simultaneously.



REF# B-33581

Double Taper Collet Chuck with auxiliary and manual swing Clamp for Manual Actuation. It is used in a Casting and machining operation for use on long blind, or stepped bored parts.

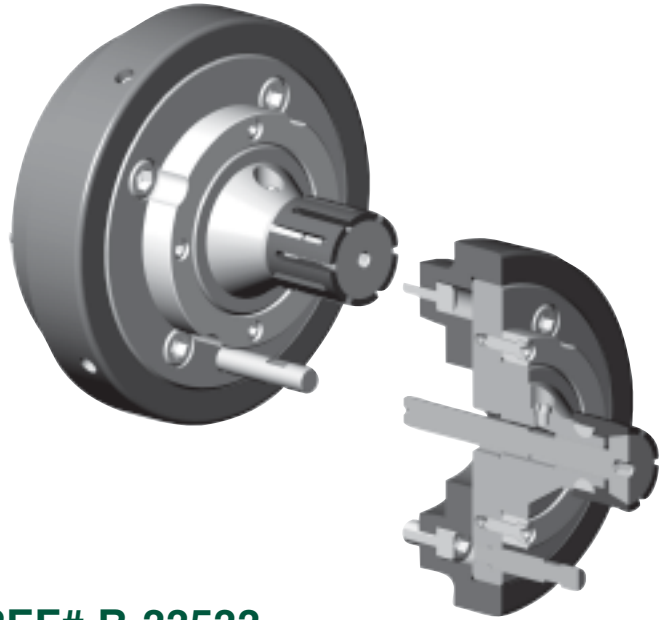

REF# B-33533

Reverse Taper Collet Chuck for dead length positioning and drawbar actuation is used by an O.E.M. manufacturer for use on parts where pull-back is not desired due to possible distortion.

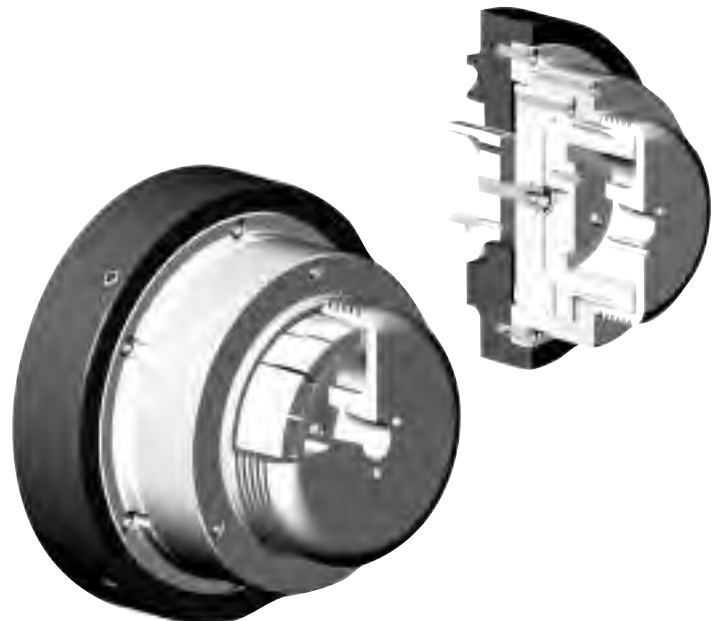

REF# B-33153

Split From One End Collet Chuck for drawtube mount to Okuma Turning Center. It is used by an electric motor manufacturer in a grooving operation on step end motor caps.

EXTERNAL DIAMETER COLLET WORKHOLDING

When you need to grip the O.D. surface for I.D. machining applications, Speedgrip provides External diameter Collet Chucks in a variety of configurations to meet your specifications.



REF# B-30286

Split From One End Collet Chuck with internal workstop used in a turning operation.



REF# B-33198

Split From One End Collet Chuck drawbar actuated, with flush slots for chip removal used in a turning operation.



REF# B-33226

Split From One End Collet Chuck with Adjustable Throw used by a major small engine manufacturer in a crankshaft grinding operation



REF# B-30629

Split From One End Collet Chuck with Radial Load Pin and access slots for an autoloader. This collet is used by an air conditioner compressor manufacturer in a turning operation.



REF# C-9124

Split From One End Collet Chuck for clutch/hub transmission part used by an auto manufacturer in a turning, facing and boring operation.



REF# B-33494

Split From One End Collet Chuck for drawbar actuation used by a major heavy equipment manufacturer in shaping I.D. and O.D. of teeth for a ring gear.

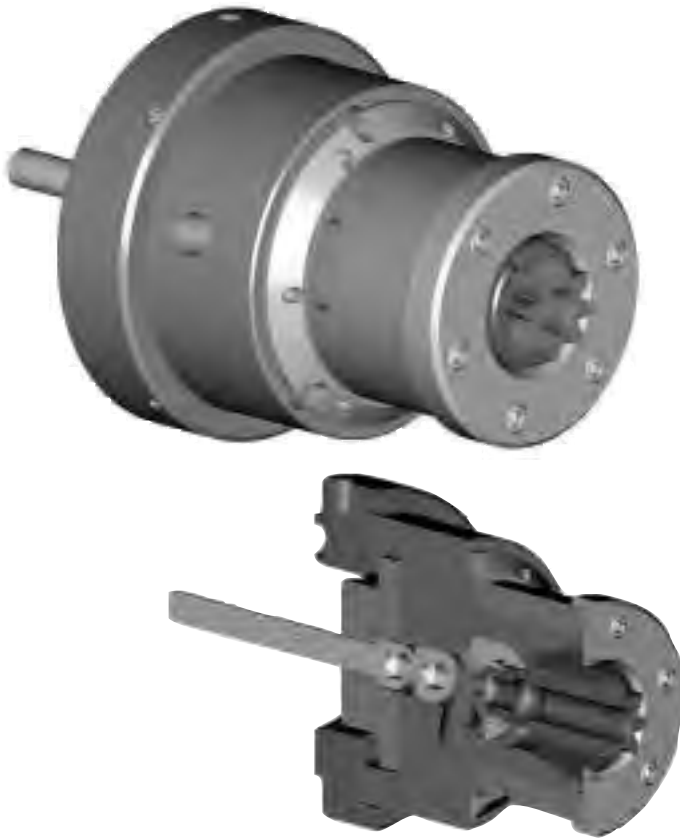

REF# B-27975

Single Taper Collet Chuck for drawbar actuation built for an O.E.M. machine manufacturer for boring and facing gear components.

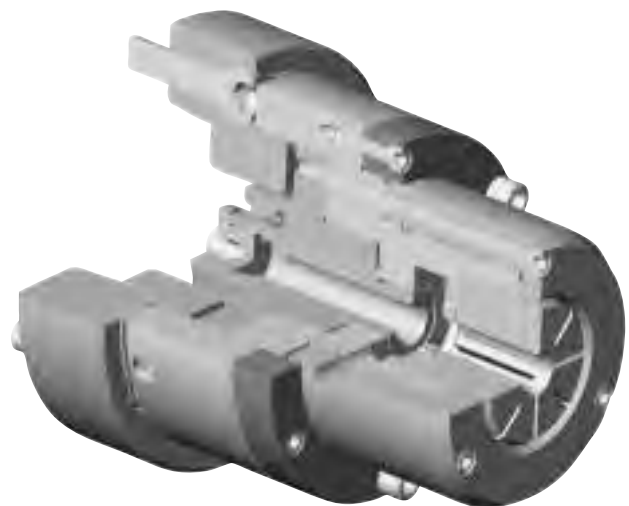

REF# Q-33562

Single Taper O.D. Collet Chuck with interchangeable collets to address a family of parts for second operation machining.

DIAPHRAGM CHUCKS

The diaphragm principle of chucking can be used for many different applications.

Parts can be held internally or externally. Depending on the design of the diaphragm, parts can be chucked lightly or with extreme pressure. In all applications it is necessary to chuck on a machined surface. In many applications the natural spring tension of the diaphragm material provides the grip force for chucking the work piece. In some applications the use of drawbar pressure can provide additional grip force. Many chucks are self-contained, having a built-in air cylinder. Air usually reaches the cylinder by means of a rotary coupling and an air line.



REF# 10A-EWE

O.D. Diaphragm Chuck used on a gear shaver in the production of automotive gears. Drawbar action is used to open the chuck and to provide additional power for chucking. The chuck is equipped with replaceable, hardened, ground pads. A hardened ground ring is used to rest the work part on. Mounting holes are capped to keep out dirt.

REF# B-15553

REF# B-15553 (unloaded)

Gear Pitch Diaphragm Chuck used for Grinding Transmission Gears. Many transmission parts require that inner bearing diameters be ground concentric to outer gear pitch diameters. When helical outer gear configurations are involved, it is difficult to allow gripping jaws to travel toward the chuck center and simultaneously follow the helical angles of the piece part teeth. Speedgrip design engineers elected to utilize a 3 jaw diaphragm type chuck due to its inherent high degree of accuracy. Each jaw contained a rotating pitch pin which could turn slightly to match the helix as it traveled in toward the center to grip the part, thus concentricity within tenths of a thousandth, could be held within the desired specifications.



QUALITY CRAFTED, COST EFFICIENT AND CAPABLE...



REF# 33286

Double Diaphragm Chuck with combination spring and drawbar assist used to grip O.D. for I.D. machining operation.



REF# 32903

O.D. Diaphragm Chuck w/ jaw inserts, spring assist to grip and a drawbar for release. This chuck is used by a major gear manufacturer for face drilling of holes in a gear blank.



REF# B4380

O.D. Diaphragm Chuck w/Self Contained Actuation for use in grinding aircraft engine parts. The gauge shown in chuck was used to check accuracy and chucking power before shipping.

CLAMP AND FINGER CHUCKS

When gripping a part on the diameter means that stress will be induced, creating distortion, Clamp Finger Chucks allow for linear holding so that these parts can be machined in their relaxed state.

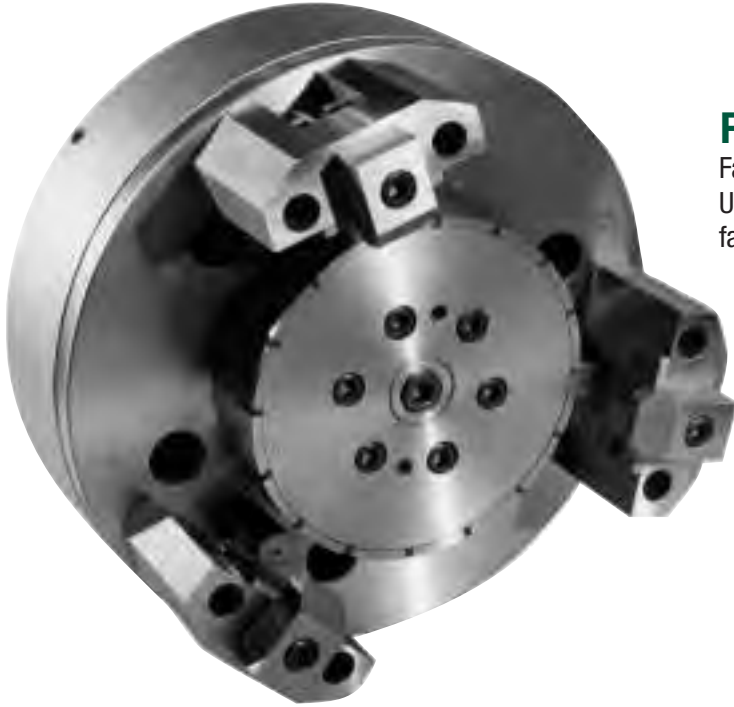

REF# Q-25152

Face Clamping Chuck with I.D. Collet for Centralizing Part. Used by an electric motor manufacturer for a turning and facing operation on aluminum end bell housings.



REF# B-15771

Pull Back Clamp Chuck with Center Face Driver. It is used by a truck transmission manufacturer for a shaft turning operation.

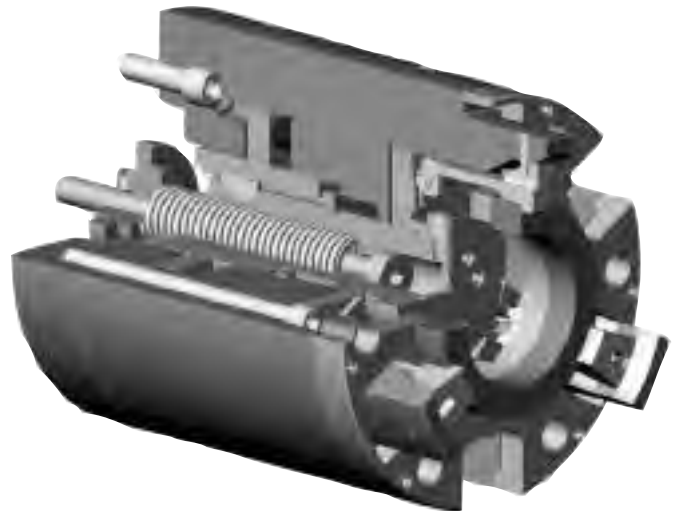

REF# Q-33866

Finger Chuck with Drawbar Actuation. It is designed to grip a sleeve component. The part is loaded on center plug when the fingers engage and the plug retreats.



REF# B-32180

Face Clamping Chuck with Radial Locator Mechanism. Used by a truck engine manufacturer to locate part radially and face clamp for wrist pin bore cross drill.

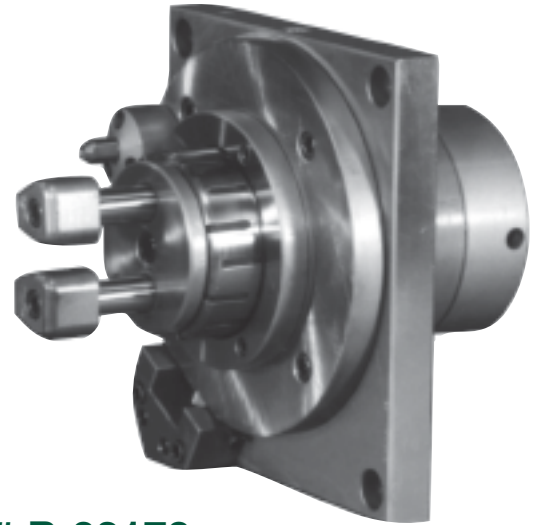

REF# B-32178

This Chuck was built for a machine tool manufacturer who was supplying tooling to a steering assembly manufacturer. It centralizes the steering knuckle with a collet, then has a swing clamp actuated by a drawbar to grip the part for an O.D. machining operation.

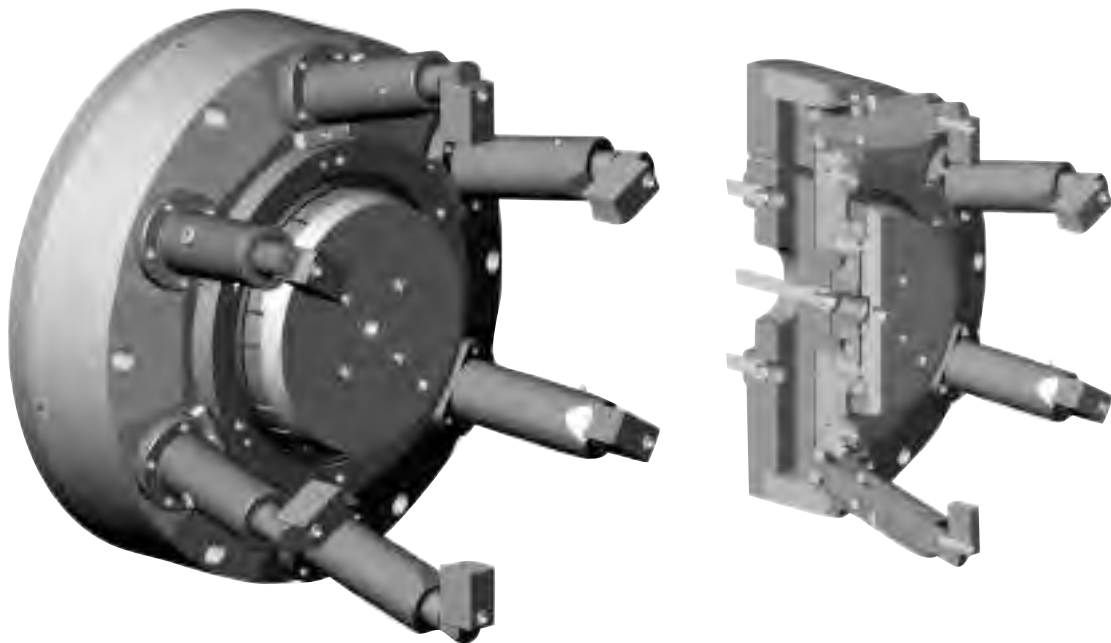

REF# Q-33173

This mechanism was designed to grip I.D. bore and with extended clamping arms to dampen casting for I.D. machining operation.

EXPANDING MANDRELS FOR MACHINING...

Speedgrip mandrels are fast, accurate, and are used for inspection as well as the machining of parts. Expandable mandrels often eliminate the necessity of holding close tolerances in a bore just to accommodate old style solid mandrels.

DOUBLE TAPER MANDRELS AND CHUCKS

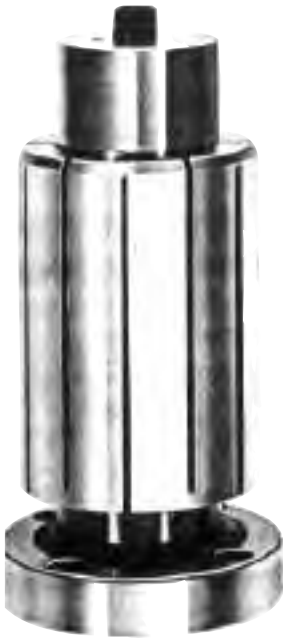

REF# 14A-EWE



REF# 14B-EWE



REF# 14C-EWE

REF# 14A-EWE

Draw bar actuated No. 4 double taper, Speedgrip Chuck. The double taper collet is sealed to protect bearing surfaces, and is 5 1/2" in diameter and 8" long. The top end of the collet is chamfered for ease of loading.

REF# 14B-EWE

Manually actuated No. 3, double taper mandrel that was designed to meet the requirements of a specific job. The work-parts are positioned against the ground flange face of the mandrel to insure machined surfaces are square with the bore.

REF# 14C-EWE

Tailstock actuated special double taper mandrel with the collet removed, thus two of the four husky keys that are used for driving the collet can be seen. The keys are inserted in milled pockets in the mandrel. The large hole through the shank accommodates a driving pin. These features are used on applications where heavy cuts require greater driving power. This particular mandrel is used on an automatic lathe where several tools are cutting simultaneously. The double taper collet is expanded with pressure from an air operated tailstock.

SPECIAL SINGLE TAPER MANDRELS



REF# 15A-EWE

Balancing mandrel. Speedgrip designs hundreds of mandrels and chucks for manufacturers and users of dynamic and static balancing equipment.



REF# 15D-EWS

Machining mandrel. The above figure shows a 22" long mandrel that is used in machining pump components.



REF# 15B-EWE REF# 15C-EWE

Inspection mandrels. The above figures show special mandrels used to inspect tractor parts.



REF# B-33476

Machining mandrel for a 12" x 60" cylinder housing for an In-line piston pump manufacturer. The mandrel has the part loaded at a separate station. It would then be placed between centers of a lathe for O.D. turn operations.

GEAR APPLICATION WORKHOLDING

Whether you need to grip on the pitch diameter, the major or minor diameter, Speedgrip can provide you with the collets and tooling to produce qualified gear components.



REF# B-33187
REF# B-33187 (unloaded)

Upper/ Lower clamp Hobbing Arbor used by a hobbing machine manufacturer to centralize gear with collet and grip part between upper and lower clamp.



REF# B-33492

This Drawbar Operated Hobbing Arbor using a double taper Collet and upper/lower clamp assembly was made for an O.E.M. machine manufacturer to produce automotive gears.



REF# B-33475

Push on Collet Hobbing Arbor used by a major heavy equipment manufacturer. Upper assembly guided by lower. Collet expands centralizing part and then clamp.

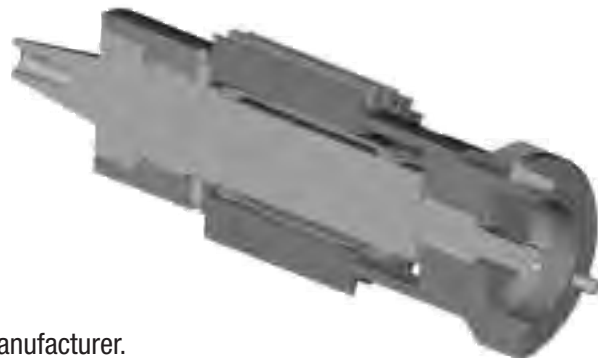

QUALITY CRAFTED, COST EFFICIENT AND CAPABLE...



REF# B-1845

Large 23" Diameter Spline Collets for gripping on the pitch diameter of a part.

REF# 17A-EWE-2

I.D. Gripping Chuck for gripping on the pitch diameter of a part.

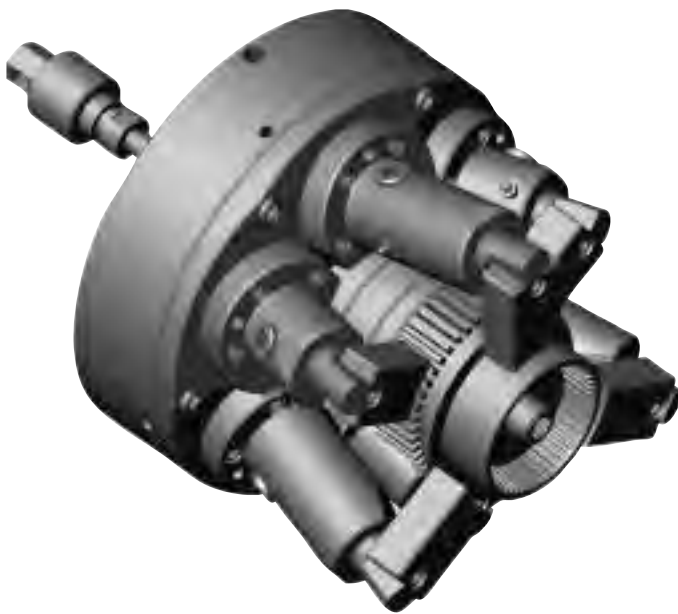

REF# Q-32750

Spring Clamp/Collet Chuck w/Air Release used by a truck transmission manufacturer. The ring gear is centralized on the internal diameter collet then gripped by spring clamps for turning and facing.



REF# B-33468

I.D. Collet chuck w/Manual Actuation & Tailstock Clamp Top Plate used by a heavy equipment manufacturer in shaping O.D. gear teeth.

FIXTURING APPLICATIONS

When workholding needs go beyond a chucking mechanism, Speedgrip has the capability to incorporate fixturing concepts into tooling to address specific machining requirements.

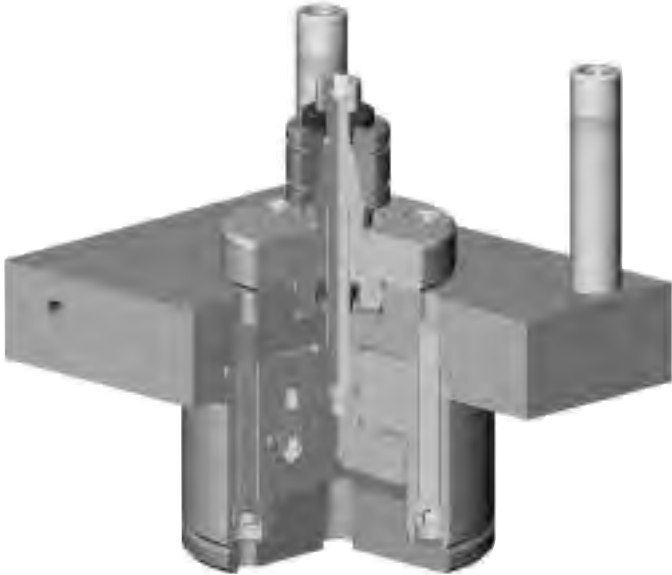

REF# Q-33512

Fixture Assembly with I.D. Collet Chuck using a segmented collet. Hydraulic cylinder integrated for actuation. Used by an original equipment machine builder in a facing operation.

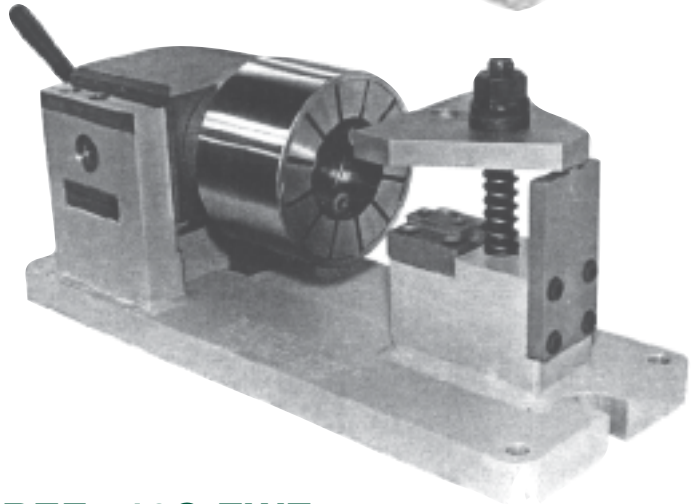
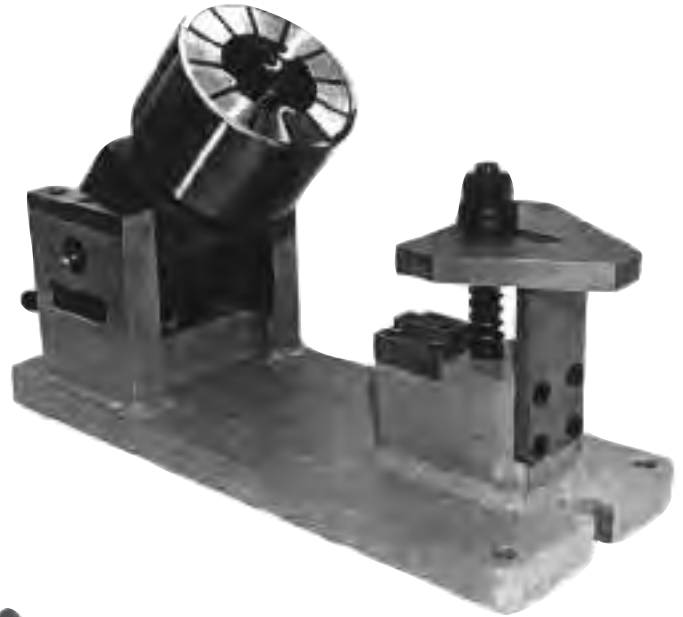

REF# 18C-EWE REF# 18D-EWE

In order to grip a universal joint yoke while boring its (2) cross trunnion holes, a problem of loading was encountered. Machine space and necessary clamping area prohibited the piece part from being loaded straight into the collet. The problem was solved by tilting the collet assembly at an upward angle as shown in 18C. The piece part was easily loaded into the collet then pivoted downward to horizontal position, as shown in 18D. The collet was activated and the clamp secured to provide a rigid and accurate means for part holding.

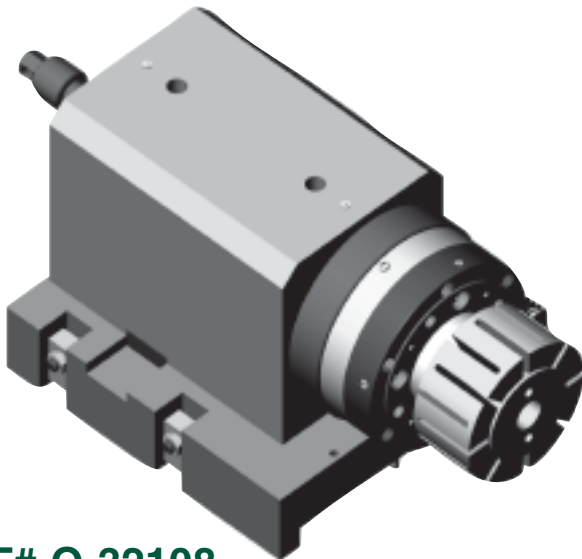

REF# Q-32108

Tailstock Chuck Assembly with built-in actuation used by a hydraulic cylinder manufacturer for use in a headstock/tailstock chucking application.

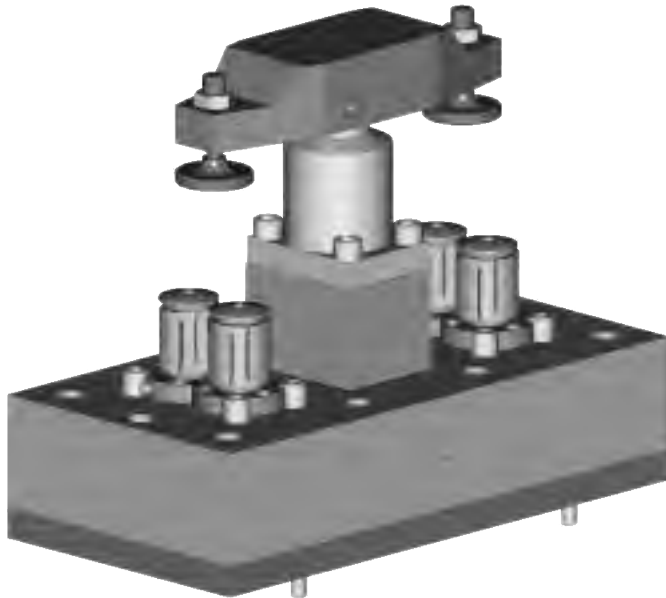

REF# Q-33213

Fixture using Two I.D. Collet chucks, one round, one diamond and hydraulic swing clamp. Actuation is hydraulic/spring release. Used by a marine engine manufacturer for holding engine block and boring crankshaft holes.

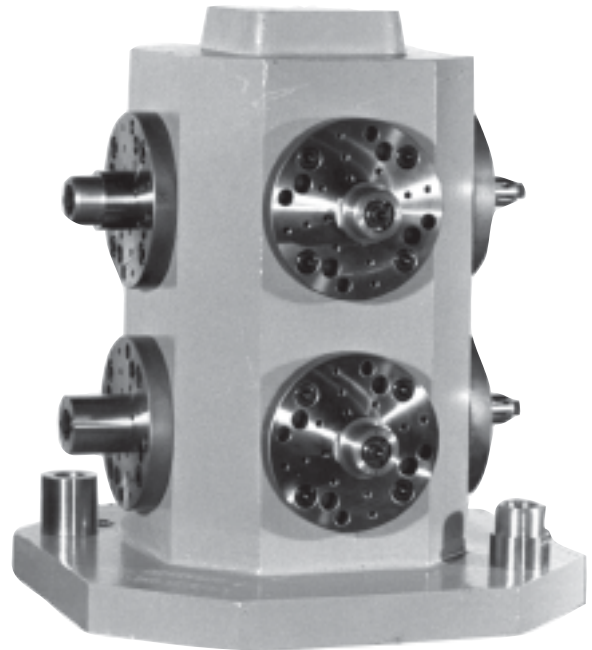

REF# 19C-EWE

8 Station Tombstone for Manual Actuation on a Horizontal Machining Center. Ideal for multi-load and presentation of parts to the cutting tool.



REF# B-16446

Sub-Plate Fixture w/ Two I.D. Diaphragm Chucks mounted for piston application. This arrangement is ideal for a horizontal machining center with a shuttle pallet or vertical machining centers.

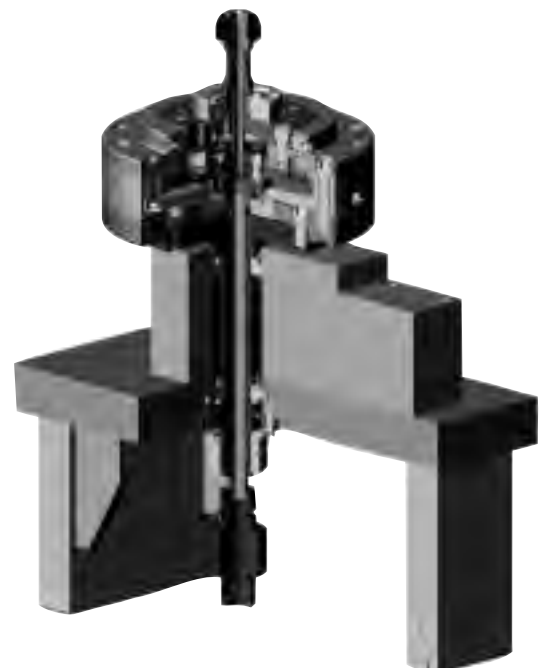

REF# B-33534

Inspection Stand with Double Taper Collet mechanism and self-contained actuator for hand spinning and checking part concentricity.

SPECIAL USE WORKHOLDING

Not all applications can be addressed by standard workholding concepts. Speedgrip has the engineering capability and experience to look beyond conventional solutions to meet your particular workholding needs.



REF# 20A-EWE

Finger Chuck used by a small engine manufacturer to locate and grip pistons for an O-ring groove operation.



REF# B-33370

This Chuck was designed for an automotive manufacturer to locate the power steering rack off its teeth so that the internal worm could be form ground.



REF# B-15329

Key Chuck used by an auto engine manufacturer to grip piston casting for first operation machining.



REF# 21A-EWE

Compensating Cyl-Chuck designed for use on thin wall first operation parts. An air bladder allows the jaws to float independently so that the part can be gripped and machined without inducing stress.



REF# 21B-EWE

Self-Centering Cyl-Chuck used by an aircraft manufacturer to perform second turning on turbine rings.



REF# Q-33230

A Special Chuck designed for a customer using centrifugal casting in their manufacturing process. The mold is gripped and spun at 400 RPM then cast iron at 1500 degrees centigrade is poured into it.



THRU-HOLE COLLET CHUCK

The Thru-Hole Collet Chuck is designed primarily for gripping of bar or tube stock. It features a master collet with interchangeable collet pads to accommodate a wide range of bar sizes.

Actuation can be accomplished by drawtube or through spindle hydraulics. The chuck utilizes this draw force plus spring pressure to securely grip the part. In the event of system failure, springs continue applying holding force, resulting in a fail-safe feature.

This chuck is designed for quick-changeover, maximum freedom from chip and coolant entry, high RPM operation and close tolerance repeatability.

The Thru-Hole Collet Chuck emphasizes quick and easy serviceability and is built to traditionally high levels of workmanship and quality. Part sizes available from 1/2" to 3" and 4 1/2" to 6" using standard pads.

Speedgrip inspection standards call for T.I.R. reading of within .0005 prior to shipment. This repeatability is measured at the insert pad mounting seat. Final accuracy is dependent upon the accuracy inherent in the collet pads.

QUICK CHANGE CAPABILITY



LARGE BAR CAPACITY



Specials Quoted Pending Application...

SPRING CHUCKING AIR OR HYDRAULIC RELEASE

Standard, Self-contained Speedgrip Actuators are practical for hundreds of applications. Spring pressure is utilized for chucking the work, thus minimizing the possibility of part loss resulting from air failure. Air or hydraulic pressure releases the work. The actuator mounts to an intermediate ADAPTER which mounts to the spindle nose. Prices for intermediate adapters will be quoted upon application. Actuators for AIR chucking and SPRING release can also be supplied if desired. Special actuators larger or smaller than standard sizes listed, are available. Special front plates can also be supplied for standard Actuators to accept our JF locators or other special chucks. Various size chuck assemblies that cover a range of sizes from 1/2" to 17" can be mounted in the four different size actuators.

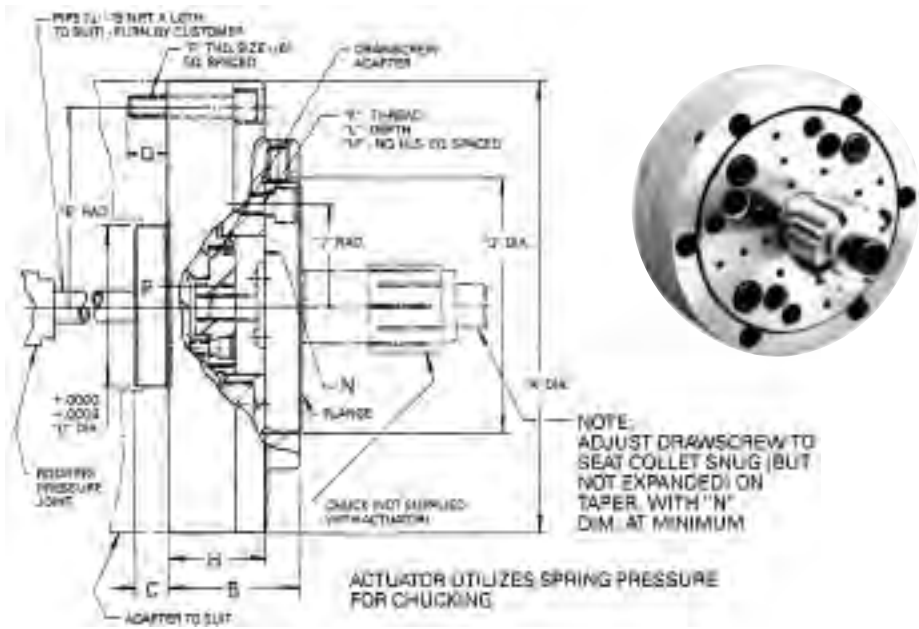

DRAWSCREW ADAPTER SIZES		
ACTUATOR NO.	ADAPTER NO.	THD. SIZE
C-8358 & C-8360	D-8416	#10-32
	D-8417	1/4-20
	D-8418	3/8-16
	D-8419	1/2-13
	D-8420	3/8-11
C-8369	D-8421	3/4-16
	D-8424	3/8-16
	D-8425	1/2-13
C-8369 & C-8370	D-8426	5/8-11
	D-8427	3/4-16
	D-6428	1"-8

FLANGE SIZE	ACTUATOR NO.	A	B	C	D	E	F	G	H	J	K	L	M	N		P	Q
														MIN	MAX		
4"	C-8358	7-3/4	2-7/32	9/16	2-3/4	3-7/16	3/8-16	4-3/8	1-5/8	1-3/4	3/8-16	1/2	3	7/16	19/32	5/8	5/8
6"	C-8360	7-3/4	2-15/16	9/16	2-3/4	3-7/16	3/8-16	6-3/8	1-5/8	2-1/2	1/2-13	1/2	4	7/16	19/32	5/8	5/8
10"	C-8369	11-1/2	3-27/32	13/16	3-3/4	5	1/2-13	10	2-7/8	3-3/4	5/8-11	15/16	4	9/16	3/4	1-1/2	7/8
13"	C-8370	14-1/2	3-27/32	13/16	3-3/4	6	1/2-13	13	2-7/8	4-7/8	5/8-11	1"	4	9/16	3/4	1-1/2	7/8

NOTE—WHEN ORDERING, SPECIFY: 1) ACTUATOR NO. 2) DRAWSCREW ADAPTER NO. 3) AIR OR HYDRAULIC RELEASE
 ACTUATOR WILL ACCEPT ANY STANDARD SINGLE, DOUBLE, OR REVERSE TAPER SPEEDGRIP CHUCK HAVING THE CORRESPONDING FLANGE SIZE.
 SPRING COMBINATION CAN BE ALTERED IF NEEDED DUE TO AVAILABLE RELEASE PRESSURE.

AIR AND HYDRAULIC ROTATING CYLINDERS

Speedgrip Chuck introduces...

The New Generation of rotating air and hydraulic cylinders.

Features:

- High speed rotation up to 7000 RPMs
- Higher operating pressure up to 1000 PSI (hyd)
- Directly interchangeable with most existing cylinder models
- Enhanced reliability with accompanying limited warranty.

Options:

- Third port for fluid distribution
- Tail rod
- Safety check valves
- Proximity switches/trip dogs
- Special stroke lengths
- Special piston rods



Service available for most competitors' models

The New Generation of rotating cylinders is built to the highest quality standards with expanded service for complete customer satisfaction.

MODEL DESIGNATION

Develop model number by selecting the symbols that represent the cylinder with the features and options required.

Place them in the sequence as shown.

Feature	Description	Symbol
Bore	Specify in inches	
Style	Air	A
	Hydraulic	H
Safety Checks	With	W
	Without	O
Options	Third Porting	P
	Tail Rod	R
	Proximity Brackets <small>(available with third port and tail rod models only)</small>	B

(ordering example)
SG 4-1/2 A W P B

SPECIALS, DESIGN AND BUILD WORKHOLDING

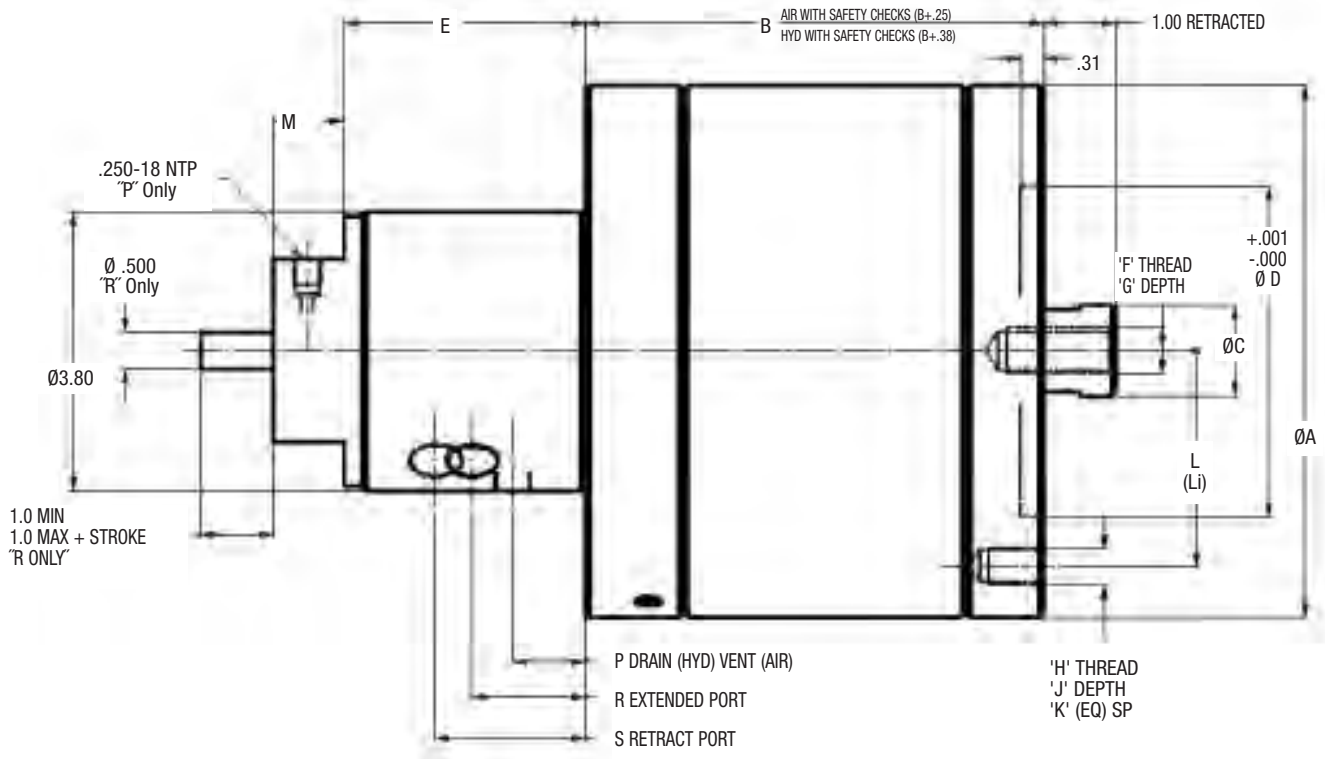

Ø BORE (in)	DIMENSIONAL DATA																	
	A	B	C	D	E				F	G	H	J	K	L	Li	M		
					'O' MODEL	'W' MODEL	'P' MODEL	'R' MODEL								'P' MODEL	'R' MODEL	
HYDRAULIC	*3	5.75	9.25	1.00	3.000	2.91	2.91	3.09	3.03	.750-16	1.80	.500-13	1.0	4	3.750	n/a	1.23	.63
	4-1/2	5.75	9.25	1.25	3.000	2.91	2.91	3.09	3.03	.750-16	1.80	.500-13	1.0	4	3.750	n/a	1.23	.63
	6	7.40	9.76	1.50	4.500	2.91	2.91	3.09	3.03	1.000-14	2.00	.500-13	1.0	4	5.500	n/a	1.23	.63
	8	9.40	9.76	1.75	4.500	2.91	2.91	3.09	3.03	1.250-12	2.30	.500-13	1.0	8	5.500	n/a	1.23	.63
	10	11.40	9.76	2.0	6.000	2.91	2.91	3.09	3.03	1.500-14	2.30	.625-11	1.1	8	9.500	n/a	1.23	.63
AIR	*3	4.60	8.33	1.00	3.000	2.91	2.91	3.09	3.03	.750-16	1.75	.375-16	.75	4	3.750	n/a	1.23	.63
	4-1/2	5.80	8.33	1.00	3.000	2.91	2.91	3.09	3.03	.750-16	1.75	.375-16	.75	4	3.750	n/a	1.23	.63
	6	7.40	8.83	1.25	4.500	2.91	2.91	3.09	3.03	.750-16	1.75	.500-13	1.00	4	5.500	n/a	1.23	.63
	8	9.60	8.83	1.25	4.500	2.91	2.91	3.09	3.03	.750-16	1.75	.500-13	1.00	4	5.500	n/a	1.23	.63
	10	11.60	8.83	1.50	6.000	2.91	2.91	3.09	3.03	1.000-14	2.00	.625-11	1.00	6	7.000	9.500	1.23	.63
12	13.50	8.83	1.50	6.000	2.91	2.91	3.09	3.03	1.000-14	2.00	.625-18	1.12	6	7.000	9.500	1.23	.63	

Ø BORE (in)	DIMENSIONAL DATA			PORTING DATA			RETRACTED AREA (sq in)	EXTENDED AREA (sq in)	SPEED (rpm)	PRESSURE (psi)	STROKE (in)	
	P	R	S	EXTEND PORT	RETRACT PORT	DRAIN VENT PORT						
HYDRAULIC	*3	1.56	1.56	2.09	SAE #10	SAE #10	SAE #6	6.1	6.8	7,000	1,000	1.0
	4-1/2	1.56	1.56	2.09	SAE #10	SAE #10	SAE #6	14.3	15.5	7,000	1,000	1.5
	6	1.56	1.56	2.09	SAE #10	SAE #10	SAE #6	25.9	27.7	7,000	1,000	2.0
	8	1.56	1.56	2.09	SAE #10	SAE #10	SAE #6	47.3	49.6	7,000	1,000	2.0
	10	1.56	1.56	2.09	SAE #10	SAE #10	SAE #6	74.8	77.9	7,000	1,000	2.0
AIR	*3	.63	1.13	1.69	.375-18 NPTF	.375-18 NPTF	.375-18 NPTF	6.3	7.1	7,000	150	1.0
	4-1/2	.63	1.13	1.69	.375-18 NPTF	.375-18 NPTF	.375-18 NPTF	15.1	15.9	7,000	150	1.0
	6	.63	1.13	1.69	.375-18 NPTF	.375-18 NPTF	.375-18 NPTF	27.0	28.3	7,000	150	1.5
	8	.63	1.13	1.69	.375-18 NPTF	.375-18 NPTF	.375-18 NPTF	49.0	50.3	7,000	150	1.5
	10	.63	1.13	1.69	.375-18 NPTF	.375-18 NPTF	.375-18 NPTF	76.8	78.5	7,000	150	1.5
12	.63	1.13	1.69	.375-18 NPTF	.375-18 NPTF	.375-18 NPTF	111.3	113.1	7,000	150	1.5	

*Safety checks not available for 3" models.

STANDARD CHUCKING COMPONENTS



Speedgrip manufactures a full line of standard I.D. Collet Chucks and Locators for manual or drawbar actuation, and Between Center Mandrels, with many items in stock. Various Single Taper, Double Taper, and Reverse Taper collets in various sizes from .500 to 17" diameter are standard with special sizes and configurations available by quote.



Air and hydraulic actuators with spring chucking feature available for stationary or rotating applications.

Spindle adapters for various machines

Nose Plates in 4", 6", 10", and 13" diameters.
Nose Plates drilled and tapped to accommodate workstops.



Collets in various tapers with .0005 repeatability standard.



Draw Screw for manual or drawbar actuation.

QUALITY CRAFTED, COST EFFICIENT AND CAPABLE...

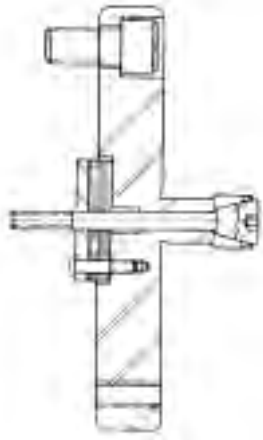

STANDARD CHUCKING ASSEMBLY

For use with spindle adapters which provide the “stir-around” feature for accuracy. Supplied for manual or drawbar actuation and applicable to turning, milling, grinding and many other uses.

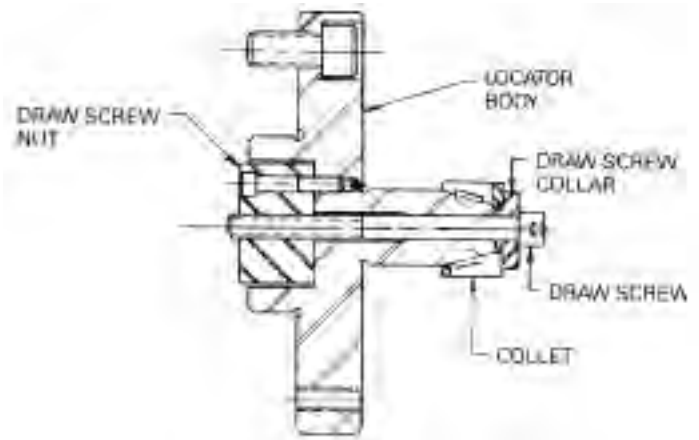

LOCATOR ASSEMBLY

For use as a fixture component with its ground pilot, for position accuracy. Designed for manual or drawbar actuation on subplates, angle plates and tombstones.

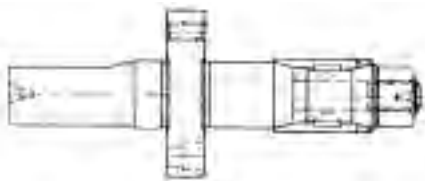

BETWEEN CENTER MANDREL ASSEMBLIES

Primarily for between center workholding applications but adaptable to hobbing, inspection and other applications.

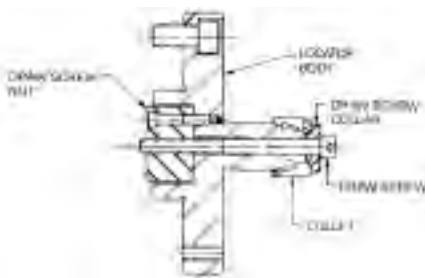

SINGLE TAPERS

Provide parts with radial grip force while pulling them back against a locating surface for zero position accuracy. Ideal for bores with longer diameter to length ratios, stepped bores or blind bores.

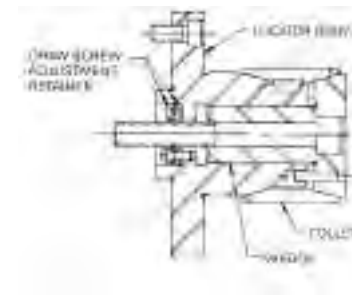

DOUBLE TAPERS

Ideal for bores with longer diameter to length ratios, stepped bores, or blind bores where radial grip force and “pull-back” action for locating the part is required.

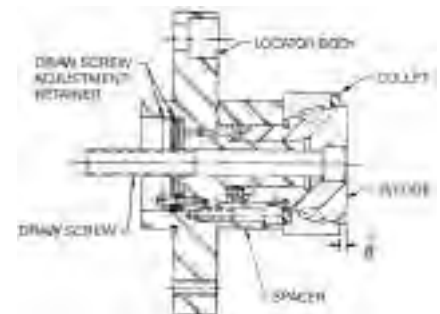

REVERSE TAPERS

For parts that require “dead length” positioning or parts that may be subject to distortion, this taper only provides radial grip force.



Cameron Sabertooth
& Hydraulic Arbors

Madison Face Driver
www.speedgrip.com

SPEEDGRIP CHUCK: Internal and external gripping collet chucks, diaphragm chucks, finger chucks, and between center mandrels.

CAMERON: Internal and external hydraulic chucks and arbors with collet chucks from our Sabertooth line.

MADISON FACE DRIVER: Standard drivers and pins along with special design face drivers and featuring our Hydra-Drive line for extreme accuracy requirements.

Our workholding equipment is very versatile and ideal for turning, drilling and milling operations, gear cutting and finishing, balancing, inspection equipment, and many uses on fixtures and tombstones.

Our standard lines offer in stock chucks, collets, mandrels, actuators, adapters, drivers, and pins for immediate delivery.

Many applications can be fully accommodated using our off-the-shelf standard items.

Our engineers will custom-design solutions for your special workholding applications and have a multitude of existing drawings available for your review.

www.speedgrip.com