



Speedgrip “Finger Collet”

A solution to part distortion during machining.



COMPLETE
METALWORKING
SOLUTIONS

(800) 991-4225
www.ahbinc.com
ISO Certified
customerservice@ahbinc.com

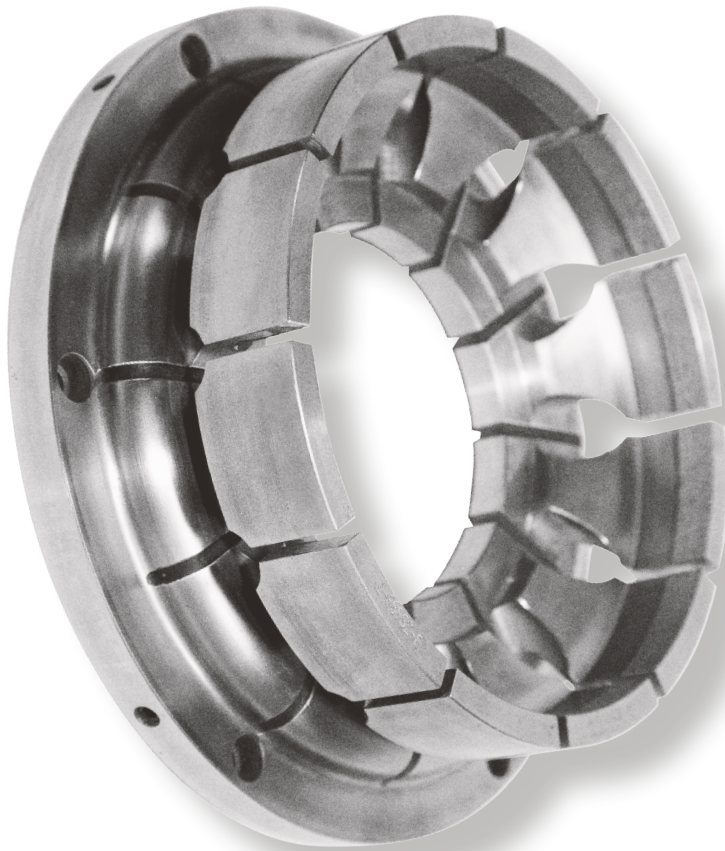

Finger Collet – a hybrid
Part Diaphragm and Part Collet

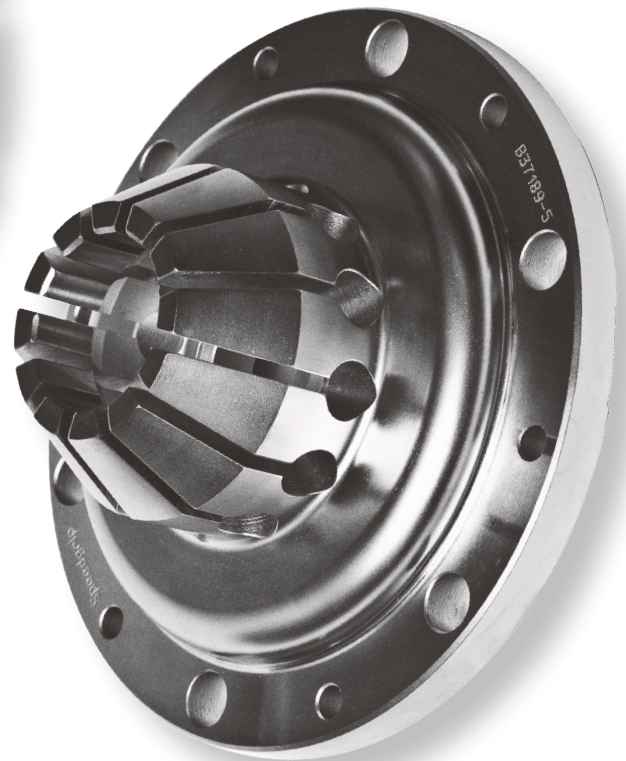

Individual grip fingers for part support and compensation

Speedgrip “Finger” chuck

The finger chuck is engineered to conform to the part rather than the part taking on the form of the workholding as most conventional chucks do.

- Merges the attributes of a diaphragm and collet chuck
- One piece “flex” plate provides excellent concentricity and repeatability
- 360 degree wrap for ultimate part support
- Individual fingers for contour compensation
- Engineered to hold with “just the right amount” of pressure for machining operation



B-36827
External Gripping Finger Chuck

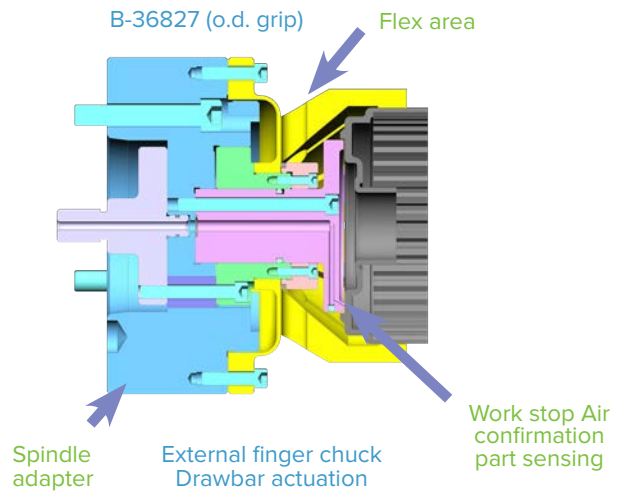
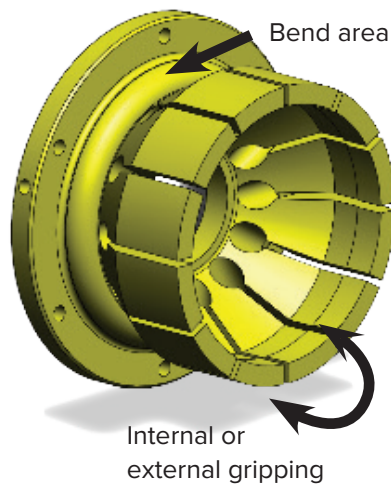

B-36827
Internal Gripping Finger Chuck

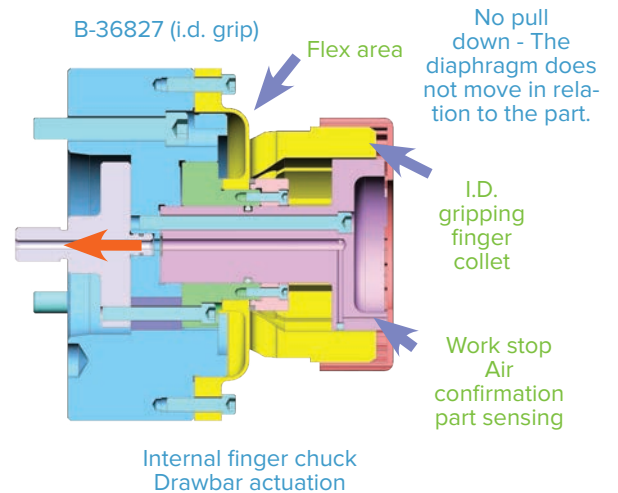
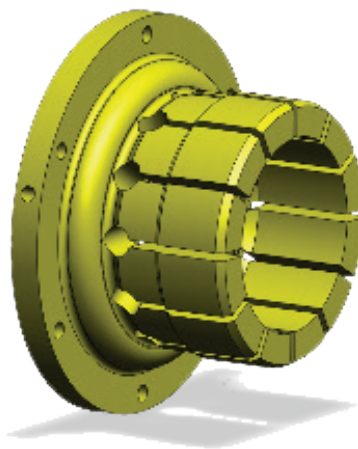

Although a chuck cannot truly be 100% distortion free the Speedgrip “Finger” Chuck is an amazing solution for meeting the ever increasing need for distortion reducing workholding.

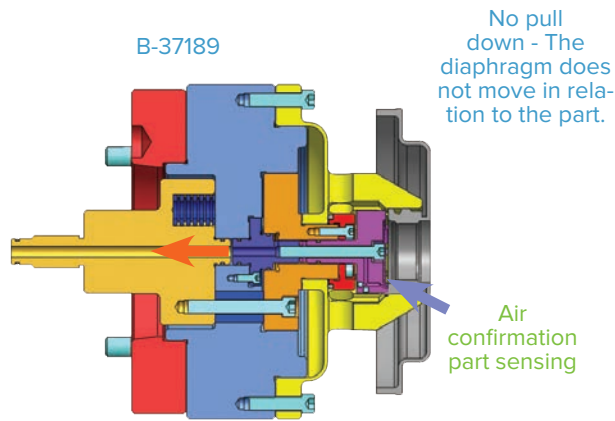
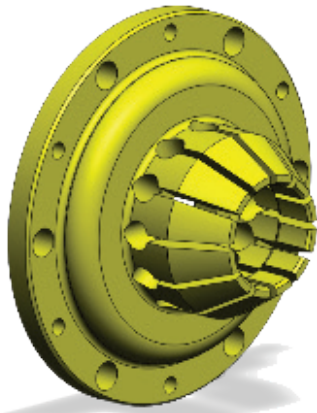

B-37189
External Gripping Finger
Chuck

External finger chuck
Drawbar actuation

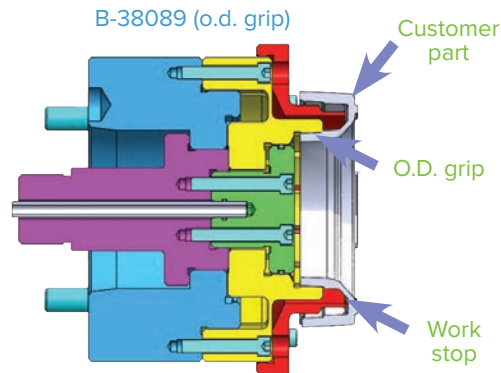
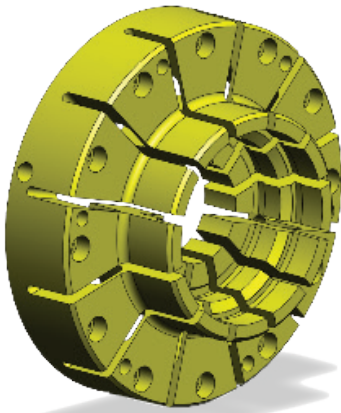

B-38089
External Gripping Finger
Chuck

External finger chuck
Drawbar actuation

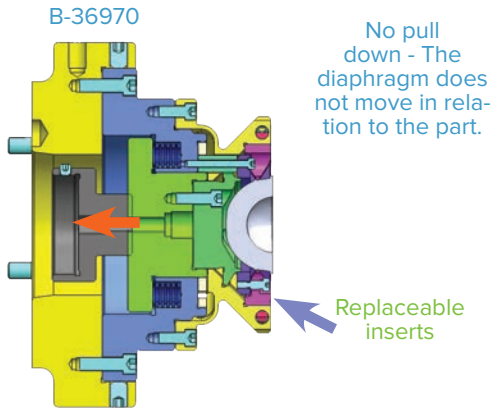

B-36970
External Gripping Finger
Chuck

External finger chuck
Drawbar actuation

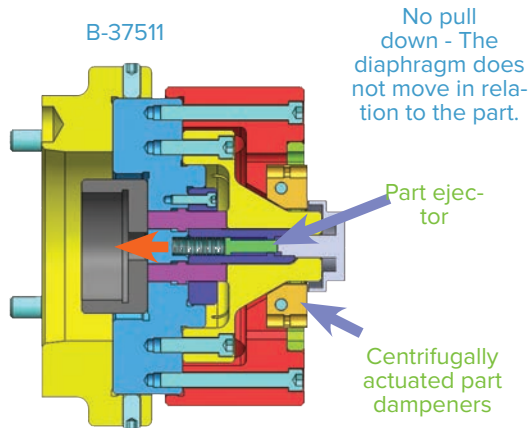
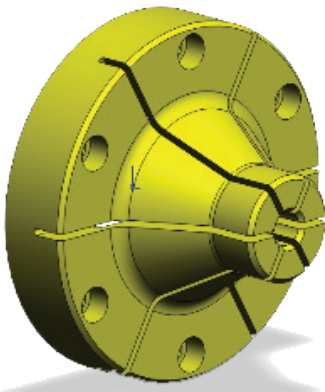

B-37511
External Gripping Finger
Chuck

External finger chuck
Drawbar actuation

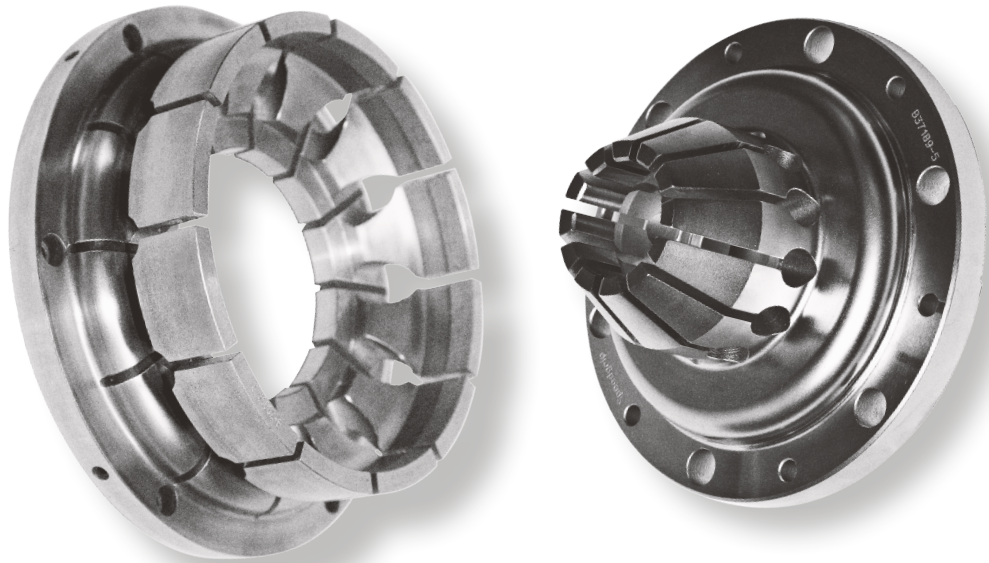

SPEEDGRIP CHUCK: Internal and external gripping collet chucks, diaphragm chucks, finger chucks, and between center mandrels.

CAMERON: Internal and external hydraulic chucks and arbors with collet chucks from our Sabertooth line.

MADISON FACE DRIVER: Standard drivers and pins along with special design face drivers and our Hydra-Drive line for extreme accuracy requirements.

Our workholding equipment is very versatile and ideal for turning, drilling and milling operations, gear cutting and finishing, balancing, inspection equipment, and many uses on fixtures and tombstones.

Our standard lines offer in stock chucks, collets, mandrels, actuators, adapters, drivers, and pins for immediate delivery.

Many applications can be fully accommodated using our off-the-shelf standard items.

Our engineers will custom-design solutions for your special workholding applications and have a multitude of existing drawings available for your review.