



# Hydra-Drive

## Madison Face Driver



**The Convenience of a Face Driver | The Accuracy of a Hydraulic Arbor**

**Accuracy | Efficiency | Quality | Flexibility**



**COMPLETE  
METALWORKING  
SOLUTIONS**

(800) 991-4225  
www.ahbinc.com  
ISO Certified  
customerservice@ahbinc.com

SPG1001 RR318

# Hydra-Drive Face Driver by Madison

## Hydra-Drive Face Driver by Madison

*.0002 T.I.R. with positive lateral positioning*

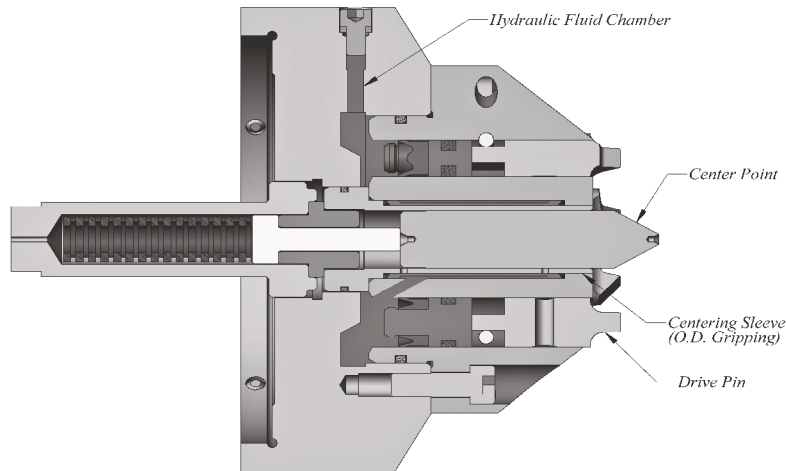

*The convenience of a face driver with the accuracy of a hydraulic arbor*

3 sizes to handle a range of part diameters from 1.000" to 6.000" diameter.

- HD 62 from 1.000" to 3.600" Diameter
- HD 63 from 1.400" to 4.800" Diameter
- HD 64 from 1.900" to 6.000" Diameter

All Drivers use standard quick change drive pins

## Features

### Accuracy

The precision ground hydraulic shell holds the center point on centerline within .0002" T.I.R. Lateral positioning of the part is constant since the center point is locked into position.

### Efficiency

Since part positioning is done by the center point, drive pin life is extended. Drive pins and center points are quickly changed from the front of the assembly. The new Hydra-Drive requires less tailstock pressure to maintain engagement.

### Quality

This new face driver combines the quality and innovation of our Madison Face Driver with Cameron hydraulic chucks and arbors.

### Flexibility

Adapts to American Standard, Morse Taper, and jaw chuck mountings. Ability to handle greater side loads during hobbing or grinding applications.