



Madison Face Driver

Max-Life[®]
D R I V E P I N S



COMPLETE
METALWORKING
SOLUTIONS

(800) 991-4225
www.ahbinc.com
ISO Certified
customerservice@ahbinc.com

The Longest Lasting Drive Pins on the Market



Durable
Cost effective
Saves set-up time
Cuts pin replacements



Interchangeable with Standard Pins

Madison Face Driver
Max-Life[®]
D R I V E P I N S

The Longest Lasting Drive Pins on the Market

Call Madison Face Driver or your Local Madison Sales Representative today for more information on our Max-Life[®] Drive Pins

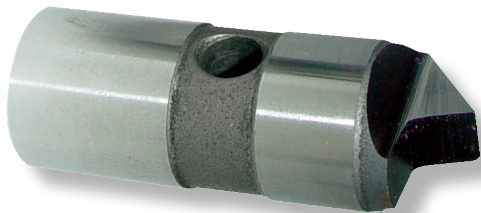
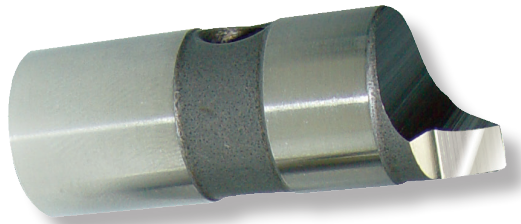
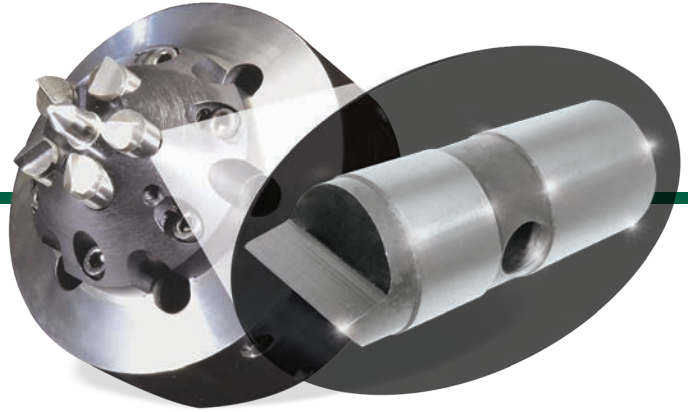

The Max-Life[®] Drive Pins, developed by Madison Face Driver, are engineered and manufactured using an all new concept that is unique to Madison drive pins. They are proven to be the longest lasting drive pins on the market today.

Tested by a leading automotive manufacturer, Max-Life[®] Drive Pins have performed with a life cycle that is 2 to 4 times greater than standard drive pins. The increased life span results in using fewer pins and saving costly set-up time making Max-Life[®] the most cost effective choice in drive pins available.

The Max-Life[®] Drive Pins are interchangeable with standard drive pins and are manufactured to the highest quality standards for complete customer satisfaction.

Check out our web site at: www.speedgrip.com or call today for more information on the new revolutionary Max-Life[®] Drive Pins.

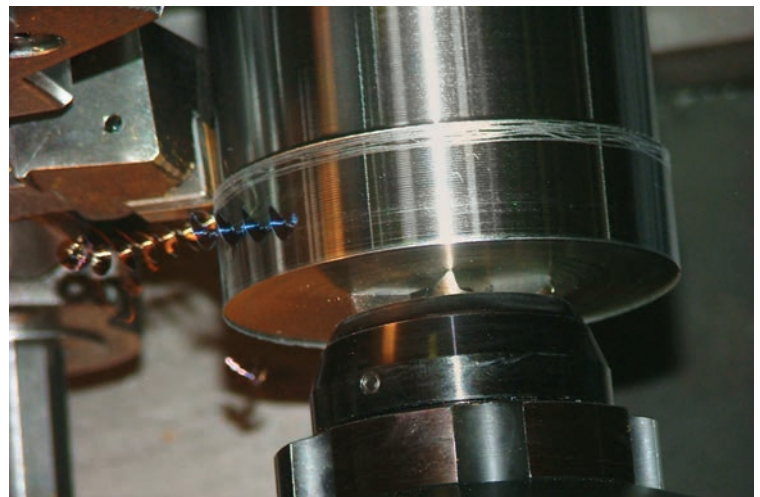

(800) 991-4225

www.ahbinc.com • customerservice@ahbinc.com

ISO Certified