



**COMPLETE
METALWORKING
SOLUTIONS**

(800) 991-4225

www.ahbinc.com

ISO Certified

customerservice@ahbinc.com

Mini Actuators

The "mini actuator" is a powerful actuator with the holding power of a conventional actuator in nearly half the space.

At only 4½ diameter, the actuator provides chucking forces for our standard chucks and many custom designs.

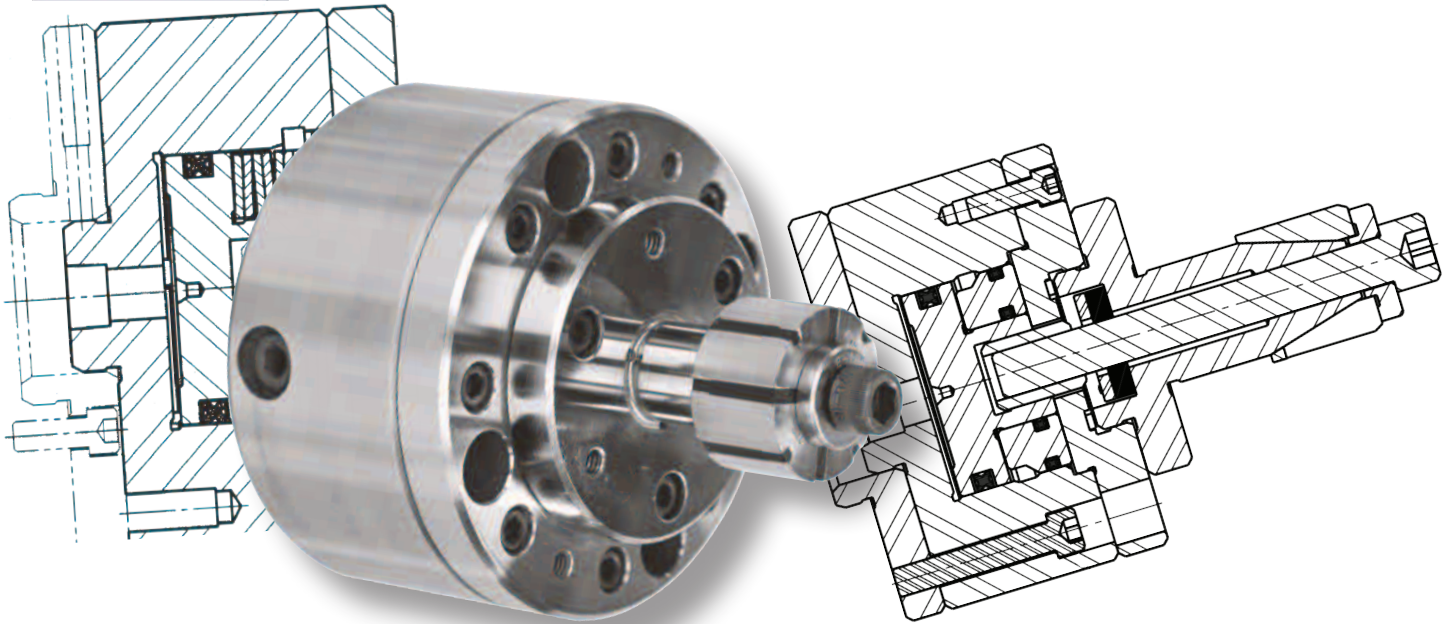

Ideal for tombstones, fixture plates, pallets, spindles, and more.

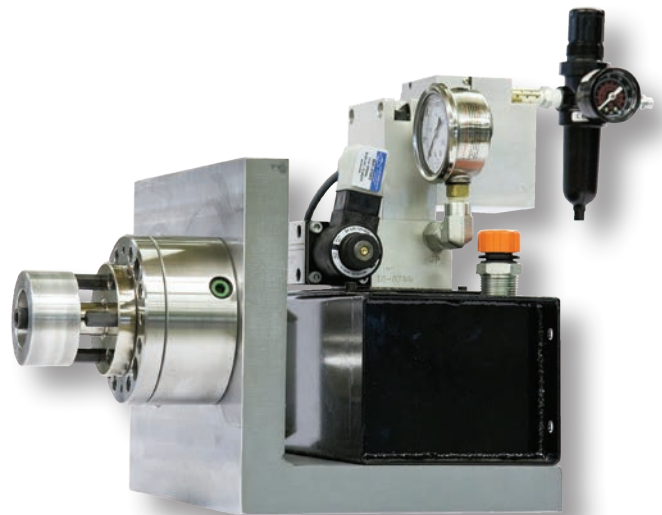
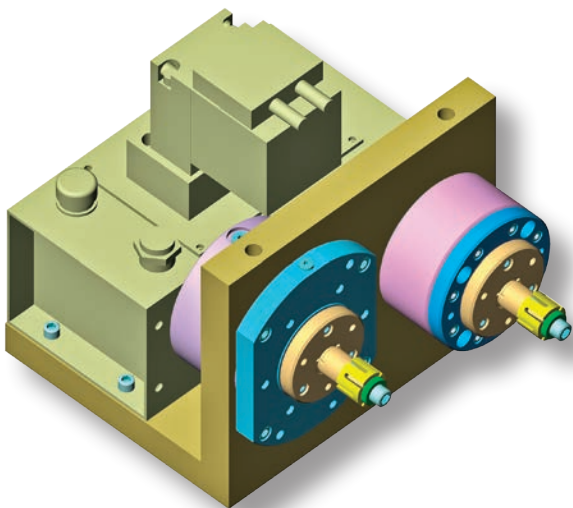

MINI ACTUATORS

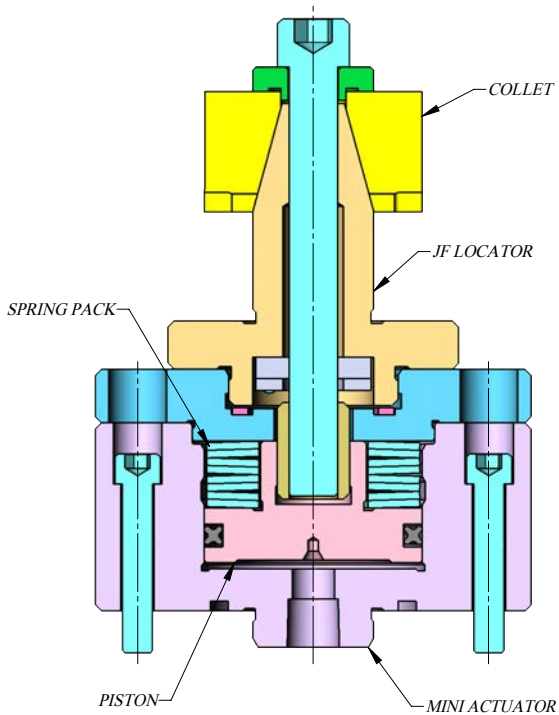

Mini actuators using spring washers to chuck are released via hydraulic port (side or bottom)

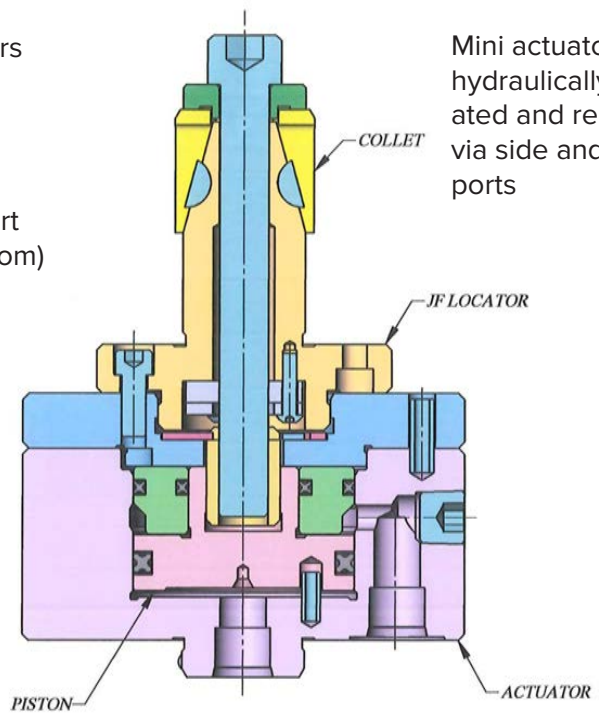

Mini actuator hydraulically actuated and released via side and bottom ports

The Speedgrip Mini Actuator provides chucking forces to accommodate standard locators as well as custom internal and external gripping chucks

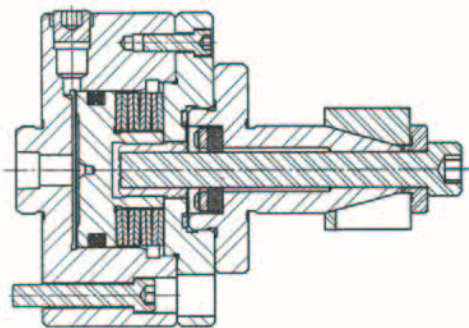

Mini Actuator with standard JF Locator (ID Grip-

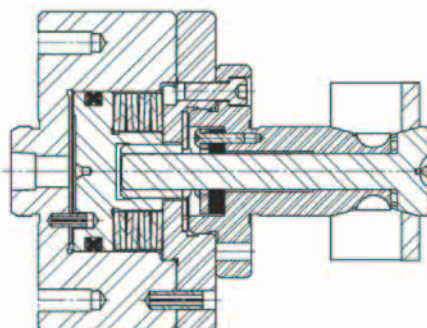

Mini Actuator with Double Taper Locator

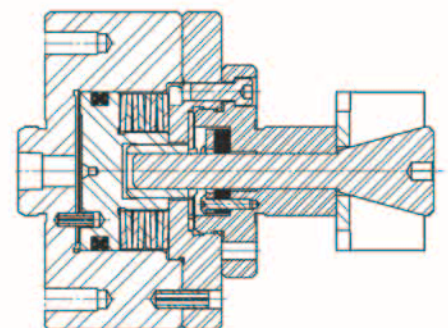

Mini Actuator with Reverse Taper Locator

Ideal for tombstones, fixture plates, pallets, spindles, and more.

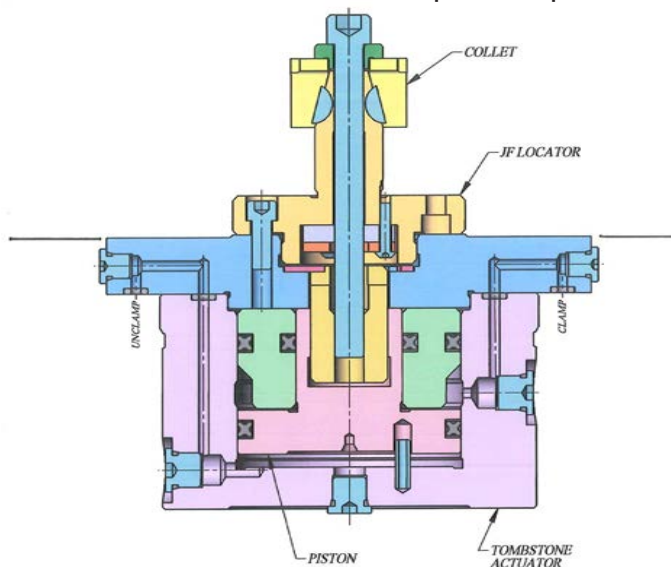

New version

Recesses completely into fixture, tombstone, or pallet and all actuation & release ports are accessible from inside or backside.

SPRING CHUCK WITH HYDRAULIC RELEASE

ACTUATOR	A	B	C	D	E	F	G	H	J	K	L	M
B-10489	4.50	1.7500	1.2500	.06	.44	2.50	(4) .313-18	1.813	1.813	(3) .250-20	1.125	.41
B-10499	4.88	2.7500	2.0000	.17	.46	3.28	(4) .375-16	2.000	2.000	(4) .375-16	2.000	.44

SPRING AND CYLINDER DATA					
ACTUATOR NUMBER	SPRING PRESSURE		CYLINDER AREA	VOLUME (cu. in.)	REQUIRED RELEASE PRESSURE
	RELAXED STATE	MAXIMUM STROKE			
B-10489	2,110 lbs	1,588 lbs	3.97 in ²	.294	610 psi
B-10499	3,170 lbs	2,386 lbs	6.49 in ²	1.103	525 psi

NOTE: UNITS BUILT WITH SPRINGS AS SHOWN; ADDITIONAL PRESSURES AVAILABLE UPON REQUEST

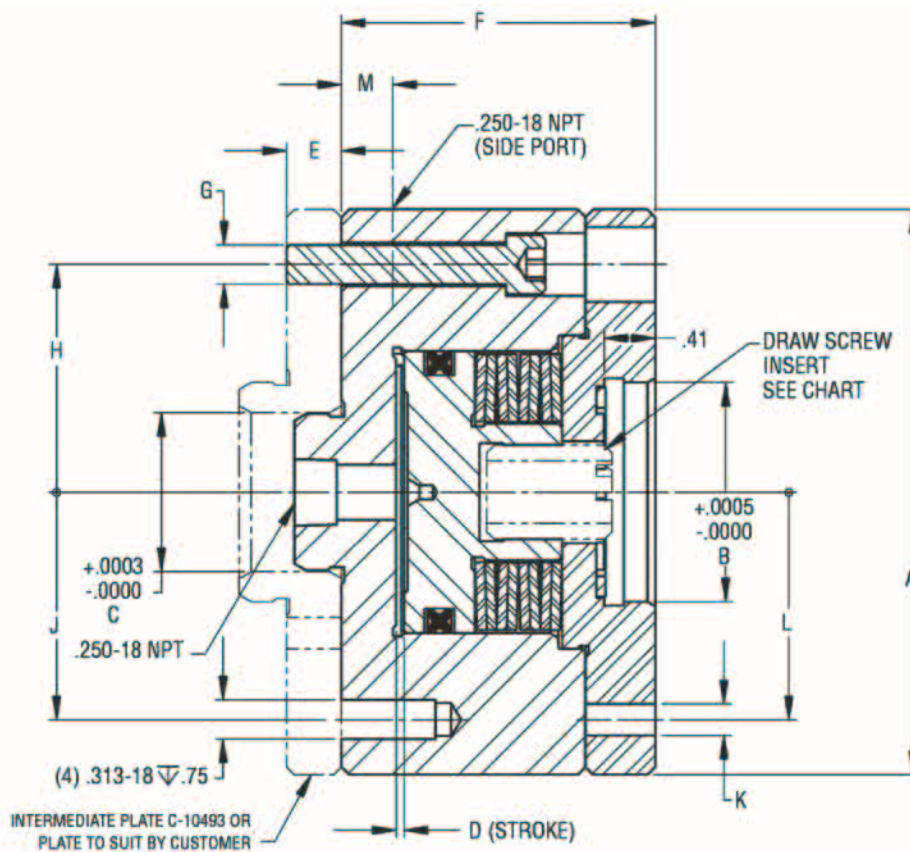

The mini actuators list below accommodates all taper sizes from #0 through #4

B-10489: locators with taper sizes 0, 1/2, 1, 2, and 2 1/2

B-10499: locators with taper sizes 3, 3 1/2, and 4

LOCATOR SIZE (JF, RTL, DTL, DTLL)	USE WITH ACTUATOR	DRAWSCREW INSERT	THREAD SIZE	NOSE SIZE	DRAWSCREW RETAINER
0, 1/2, 1, 2, 2 1/2	B-10489	E-10494	10-32	0	E-10498
		E-10495	.250-20	1/2, 1	
		E-10496	.375-16	2	
		E-10497	.500-13	2 1/2	
3, 3 1/2, 4	B-10499	E-10505	.625-11	3	E-10503
		E-10506	.750-16	3 1/2, 4	



SPEEDGRIP CHUCK: Internal and external gripping collet chucks, diaphragm chucks, finger chucks, and between center mandrels.

CAMERON: Internal and external hydraulic chucks and arbors with collet chucks from our Sabertooth line.

MADISON FACE DRIVER: Standard drivers and pins along with special design face drivers and our Hydra-Drive line for extreme accuracy requirements.

Our workholding equipment is very versatile and ideal for turning, drilling and milling operations, gear cutting and finishing, balancing, inspection equipment, and many uses on fixtures and tombstones.

Our standard lines offer in stock chucks, collets, mandrels, actuators, adapters, drivers, and pins for immediate delivery.

Many applications can be fully accommodated using our off-the-shelf standard items.

Our engineers will custom-design solutions for your special workholding applications and have a multitude of existing drawings available for your review.

www.speedgrip.com