

MagVISE Workholding Systems

Magnetic Chucks



We Provide Turn-Key Magnetic Workholding Solutions

Contact us for solutions to your workholding bottlenecks.

MagVISE
WORKHOLDING

Modular Chucks



Horizontal Chucks



Indexing Chucks

Round Chucks

For lathe and vertical turning or grinding

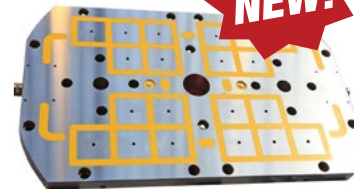
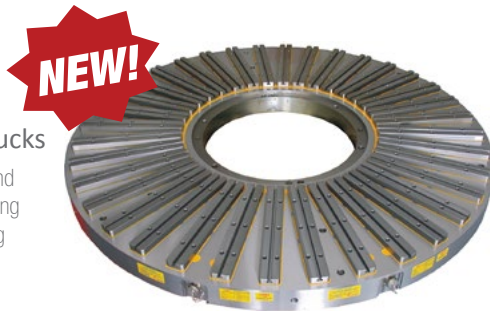

Injection Mold Clamping

Magnetic Vises



Surface Grinding



Built for Speed.



View Magnetic Workholding videos at:
<http://ow.ly/tL1Yo>

All Techniks products are backed by our 100% satisfaction guarantee!

Our People and Experience Make The Difference



Depend On Us

We're large enough to have the talent and resources you need, but small enough to respond quickly and get to know your business on a personal level.

Engineered Turn-Key Solutions

Our team has been doing magnetic workholding installations for over 10 years. Tap into our experience solving tough manufacturing process problems. We can help you become more competitive and improve your bottom line.

Our engineered solutions are proved-out at our Tech Center and are guaranteed to perform as advertised.

We Go The Extra Mile

Our "Roadshow" program brings the benefits of attending one of our trade show events right to your facility. We will provide live product demonstrations and answer your questions about magnetic workholding, material transport and CNC tooling. While we are there we can verify the holding power of your magnetic chucks (see below).

Call (800) 597-3921 to schedule a visit.

Magnetic Chuck Verification

Ever wonder if the magnetic chucks you own are still producing their maximum holding power?

Our experts will come to your facility and quickly perform a complimentary holding power check on ALL your magnetic chucks, and give you a detailed report on the condition and functionality of all your chucks and controls.



Our entire team is committed to providing the information and solutions you are looking for.

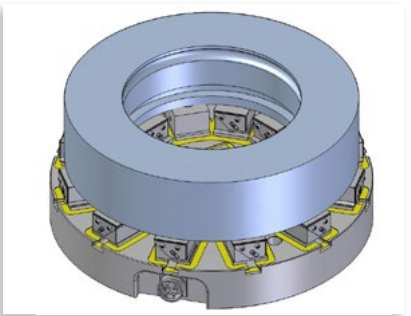
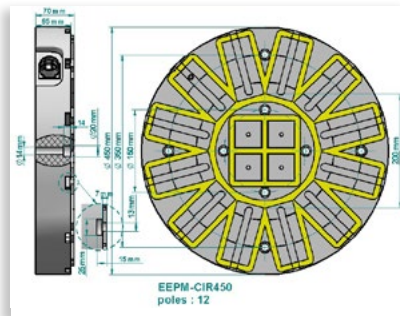

Design – Build – Install – We work closely with your team to ensure your complete satisfaction.



We'll bring a van chock-full of magnetic workholding , material lifting, and CNC tooling solutions for live demos.



Machine #	Model #	Date of Function	PS Reading	Machine #	Model #	Date of Function	PS Reading
Machine 007	Machine 007	Machine 007	Machine 007	Machine 007	Machine 007	Machine 007	Machine 007
Machine 008	Machine 008	Machine 008	Machine 008	Machine 008	Machine 008	Machine 008	Machine 008
Machine 009	Machine 009	Machine 009	Machine 009	Machine 009	Machine 009	Machine 009	Machine 009
Machine 010	Machine 010	Machine 010	Machine 010	Machine 010	Machine 010	Machine 010	Machine 010
Machine 011	Machine 011	Machine 011	Machine 011	Machine 011	Machine 011	Machine 011	Machine 011
Machine 012	Machine 012	Machine 012	Machine 012	Machine 012	Machine 012	Machine 012	Machine 012
Machine 013	Machine 013	Machine 013	Machine 013	Machine 013	Machine 013	Machine 013	Machine 013
Machine 014	Machine 014	Machine 014	Machine 014	Machine 014	Machine 014	Machine 014	Machine 014
Machine 015	Machine 015	Machine 015	Machine 015	Machine 015	Machine 015	Machine 015	Machine 015
Machine 016	Machine 016	Machine 016	Machine 016	Machine 016	Machine 016	Machine 016	Machine 016
Machine 017	Machine 017	Machine 017	Machine 017	Machine 017	Machine 017	Machine 017	Machine 017
Machine 018	Machine 018	Machine 018	Machine 018	Machine 018	Machine 018	Machine 018	Machine 018
Machine 019	Machine 019	Machine 019	Machine 019	Machine 019	Machine 019	Machine 019	Machine 019
Machine 020	Machine 020	Machine 020	Machine 020	Machine 020	Machine 020	Machine 020	Machine 020
Machine 021	Machine 021	Machine 021	Machine 021	Machine 021	Machine 021	Machine 021	Machine 021
Machine 022	Machine 022	Machine 022	Machine 022	Machine 022	Machine 022	Machine 022	Machine 022
Machine 023	Machine 023	Machine 023	Machine 023	Machine 023	Machine 023	Machine 023	Machine 023
Machine 024	Machine 024	Machine 024	Machine 024	Machine 024	Machine 024	Machine 024	Machine 024
Machine 025	Machine 025	Machine 025	Machine 025	Machine 025	Machine 025	Machine 025	Machine 025
Machine 026	Machine 026	Machine 026	Machine 026	Machine 026	Machine 026	Machine 026	Machine 026
Machine 027	Machine 027	Machine 027	Machine 027	Machine 027	Machine 027	Machine 027	Machine 027
Machine 028	Machine 028	Machine 028	Machine 028	Machine 028	Machine 028	Machine 028	Machine 028
Machine 029	Machine 029	Machine 029	Machine 029	Machine 029	Machine 029	Machine 029	Machine 029
Machine 030	Machine 030	Machine 030	Machine 030	Machine 030	Machine 030	Machine 030	Machine 030
Machine 031	Machine 031	Machine 031	Machine 031	Machine 031	Machine 031	Machine 031	Machine 031
Machine 032	Machine 032	Machine 032	Machine 032	Machine 032	Machine 032	Machine 032	Machine 032
Machine 033	Machine 033	Machine 033	Machine 033	Machine 033	Machine 033	Machine 033	Machine 033
Machine 034	Machine 034	Machine 034	Machine 034	Machine 034	Machine 034	Machine 034	Machine 034
Machine 035	Machine 035	Machine 035	Machine 035	Machine 035	Machine 035	Machine 035	Machine 035
Machine 036	Machine 036	Machine 036	Machine 036	Machine 036	Machine 036	Machine 036	Machine 036
Machine 037	Machine 037	Machine 037	Machine 037	Machine 037	Machine 037	Machine 037	Machine 037
Machine 038	Machine 038	Machine 038	Machine 038	Machine 038	Machine 038	Machine 038	Machine 038
Machine 039	Machine 039	Machine 039	Machine 039	Machine 039	Machine 039	Machine 039	Machine 039
Machine 040	Machine 040	Machine 040	Machine 040	Machine 040	Machine 040	Machine 040	Machine 040
Machine 041	Machine 041	Machine 041	Machine 041	Machine 041	Machine 041	Machine 041	Machine 041
Machine 042	Machine 042	Machine 042	Machine 042	Machine 042	Machine 042	Machine 042	Machine 042
Machine 043	Machine 043	Machine 043	Machine 043	Machine 043	Machine 043	Machine 043	Machine 043
Machine 044	Machine 044	Machine 044	Machine 044	Machine 044	Machine 044	Machine 044	Machine 044
Machine 045	Machine 045	Machine 045	Machine 045	Machine 045	Machine 045	Machine 045	Machine 045
Machine 046	Machine 046	Machine 046	Machine 046	Machine 046	Machine 046	Machine 046	Machine 046
Machine 047	Machine 047	Machine 047	Machine 047	Machine 047	Machine 047	Machine 047	Machine 047
Machine 048	Machine 048	Machine 048	Machine 048	Machine 048	Machine 048	Machine 048	Machine 048
Machine 049	Machine 049	Machine 049	Machine 049	Machine 049	Machine 049	Machine 049	Machine 049
Machine 050	Machine 050	Machine 050	Machine 050	Machine 050	Machine 050	Machine 050	Machine 050
Machine 051	Machine 051	Machine 051	Machine 051	Machine 051	Machine 051	Machine 051	Machine 051
Machine 052	Machine 052	Machine 052	Machine 052	Machine 052	Machine 052	Machine 052	Machine 052
Machine 053	Machine 053	Machine 053	Machine 053	Machine 053	Machine 053	Machine 053	Machine 053
Machine 054	Machine 054	Machine 054	Machine 054	Machine 054	Machine 054	Machine 054	Machine 054
Machine 055	Machine 055	Machine 055	Machine 055	Machine 055	Machine 055	Machine 055	Machine 055
Machine 056	Machine 056	Machine 056	Machine 056	Machine 056	Machine 056	Machine 056	Machine 056
Machine 057	Machine 057	Machine 057	Machine 057	Machine 057	Machine 057	Machine 057	Machine 057
Machine 058	Machine 058	Machine 058	Machine 058	Machine 058	Machine 058	Machine 058	Machine 058
Machine 059	Machine 059	Machine 059	Machine 059	Machine 059	Machine 059	Machine 059	Machine 059
Machine 060	Machine 060	Machine 060	Machine 060	Machine 060	Machine 060	Machine 060	Machine 060
Machine 061	Machine 061	Machine 061	Machine 061	Machine 061	Machine 061	Machine 061	Machine 061
Machine 062	Machine 062	Machine 062	Machine 062	Machine 062	Machine 062	Machine 062	Machine 062
Machine 063	Machine 063	Machine 063	Machine 063	Machine 063	Machine 063	Machine 063	Machine 063
Machine 064	Machine 064	Machine 064	Machine 064	Machine 064	Machine 064	Machine 064	Machine 064
Machine 065	Machine 065	Machine 065	Machine 065	Machine 065	Machine 065	Machine 065	Machine 065
Machine 066	Machine 066	Machine 066	Machine 066	Machine 066	Machine 066	Machine 066	Machine 066
Machine 067	Machine 067	Machine 067	Machine 067	Machine 067	Machine 067	Machine 067	Machine 067
Machine 068	Machine 068	Machine 068	Machine 068	Machine 068	Machine 068	Machine 068	Machine 068
Machine 069	Machine 069	Machine 069	Machine 069	Machine 069	Machine 069	Machine 069	Machine 069
Machine 070	Machine 070	Machine 070	Machine 070	Machine 070	Machine 070	Machine 070	Machine 070
Machine 071	Machine 071	Machine 071	Machine 071	Machine 071	Machine 071	Machine 071	Machine 071
Machine 072	Machine 072	Machine 072	Machine 072	Machine 072	Machine 072	Machine 072	Machine 072
Machine 073	Machine 073	Machine 073	Machine 073	Machine 073	Machine 073	Machine 073	Machine 073
Machine 074	Machine 074	Machine 074	Machine 074	Machine 074	Machine 074	Machine 074	Machine 074
Machine 075	Machine 075	Machine 075	Machine 075	Machine 075	Machine 075	Machine 075	Machine 075
Machine 076	Machine 076	Machine 076	Machine 076	Machine 076	Machine 076	Machine 076	Machine 076
Machine 077	Machine 077	Machine 077	Machine 077	Machine 077	Machine 077	Machine 077	Machine 077
Machine 078	Machine 078	Machine 078	Machine 078	Machine 078	Machine 078	Machine 078	Machine 078
Machine 079	Machine 079	Machine 079	Machine 079	Machine 079	Machine 079	Machine 079	Machine 079
Machine 080	Machine 080	Machine 080	Machine 080	Machine 080	Machine 080	Machine 080	Machine 080
Machine 081	Machine 081	Machine 081	Machine 081	Machine 081	Machine 081	Machine 081	Machine 081
Machine 082	Machine 082	Machine 082	Machine 082	Machine 082	Machine 082	Machine 082	Machine 082
Machine 083	Machine 083	Machine 083	Machine 083	Machine 083	Machine 083	Machine 083	Machine 083
Machine 084	Machine 084	Machine 084	Machine 084	Machine 084	Machine 084	Machine 084	Machine 084
Machine 085	Machine 085	Machine 085	Machine 085	Machine 085	Machine 085	Machine 085	Machine 085
Machine 086	Machine 086	Machine 086	Machine 086	Machine 086	Machine 086	Machine 086	Machine 086
Machine 087	Machine 087	Machine 087	Machine 087	Machine 087	Machine 087	Machine 087	Machine 087
Machine 088	Machine 088	Machine 088	Machine 088	Machine 088	Machine 088	Machine 088	Machine 088
Machine 089	Machine 089	Machine 089	Machine 089	Machine 089	Machine 089	Machine 089	Machine 089
Machine 090	Machine 090	Machine 090	Machine 090	Machine 090	Machine 090	Machine 090	Machine 090
Machine 091	Machine 091	Machine 091	Machine 091	Machine 091	Machine 091	Machine 091	Machine 091
Machine 092	Machine 092	Machine 092	Machine 092	Machine 092	Machine 092	Machine 092	Machine 092
Machine 093	Machine 093	Machine 093	Machine 093	Machine 093	Machine 093	Machine 093	Machine 093
Machine 094	Machine 094	Machine 094	Machine 094	Machine 094	Machine 094	Machine 094	Machine 094
Machine 095	Machine 095	Machine 095	Machine 095	Machine 095	Machine 095	Machine 095	Machine 095
Machine 096	Machine 096	Machine 096	Machine 096	Machine 096	Machine 096	Machine 096	Machine 096
Machine 097	Machine 097	Machine 097	Machine 097	Machine 097	Machine 097	Machine 097	Machine 097
Machine 098	Machine 098	Machine 098	Machine 098	Machine 098	Machine 098	Machine 098	Machine 098
Machine 099	Machine 099	Machine 099	Machine 099	Machine 099	Machine 099	Machine 099	Machine 099
Machine 100	Machine 100	Machine 100	Machine 100	Machine 100	Machine 100	Machine 100	Machine 100

We can perform a complimentary holding power check on all your magnetic chucks, with full report.



Questions about MagVISE Workholding?

Why should I consider magnetic workholding?

Compared to traditional fixturing methods, magnetic workholding frees up all five sides of your workpiece so you can machine the entire profile of the part in one set-up. Magnetic workholding greatly reduces set up and part change-over time, giving your spindle more time to make chips.

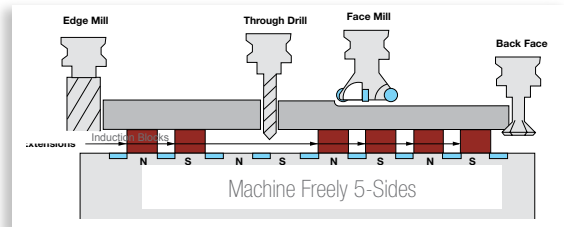

How long does magnetic workholding take to pay for itself?

Magnetic chucks pay for themselves very quickly because machine up-time and production output are increased. Every case is unique, but in most cases pay-off occurs in just a few months.

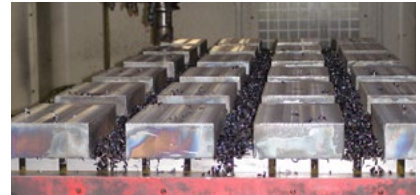

How does magnetic workholding simplify setups?

Once you have your part(s) indicated on the magnet, change-over only requires turning the magnet on/off to remove and load the parts.



What is magnetic workholding best suited for?

Thick or thin, large or small – just about any ferrous material can be held and machined magnetically. Bigger parts are easier to hold because there is more metal for the magnetism to be attracted to. For smaller parts, using work stops and nesting the part are options that work well. Magnetic workholding is used for just about any type of drilling, milling, and boring operation you can think of, on horizontal or vertical CNC machines.

How do I know magnetic workholding will work for me?

No matter what size parts you cut, we can verify your application on our “test bed” CNC so we can offer you a turn-key workholding solution. We will duplicate your application using magnetic workholding and machine your part to verify the process and document the time savings. All at no risk to you.



Should I get magnetic chucks or magnetic vises?

Magnetic vises have a smaller foot print, and are turned ON/OFF using a manual switch. Magnetic chucks require a controller to turn ON/OFF, but DO NOT require electrical connection to maintain holding power. Magnetic chucks provide more surface contact with the workpiece and feature a greater number of magnetic poles, so they can produce more holding power than magnetic vises. During a power outage magnetic chucks will not lose holding power, so they are just as safe to use as magnetic vises.



For more information you can call us at (800) 597-3921 or (317) 803-8000. Our team has been doing magnetic workholding installations for over 10 years, and in just a few minutes we can probably tell you everything you need to know.



MagVISE EEPM Magnetic Workholding Chucks

Features:

- Up to 86,625 lbs. holding power*
- Turn chuck ON/OFF in only a few seconds – chuck will not lose magnetism if a power loss occurs
- Induction blocks and subplates provide additional setup options for holding small parts or warped stock

Advantages:

- Machine freely on 5-sides & top so you can cut the full part profile in only 1 operation
- Reduce setup & part change-over time by 50% or more!
- Very uniform holding = No workpiece deformation

EEPM chucks includes control and remote



*26 sizes available
See page 218 for holding power ratings.
For workholding of ferrous materials only.

Use magnetic workholding to speed up drilling, milling, and boring operations on either thick or thin workpieces. Magnetic chucks make setup and part change-over faster and safer, and reduce the number of required operations.

Our magnetic chucks easily integrate with pallet changing and tombstone systems used in production cells. Choose magnetic workholding for uniform holding of the workpiece, without part distortion or dead spots. Uniform workholding reduces chatter and harmonics for improved surface finish and tool life.

Application Examples

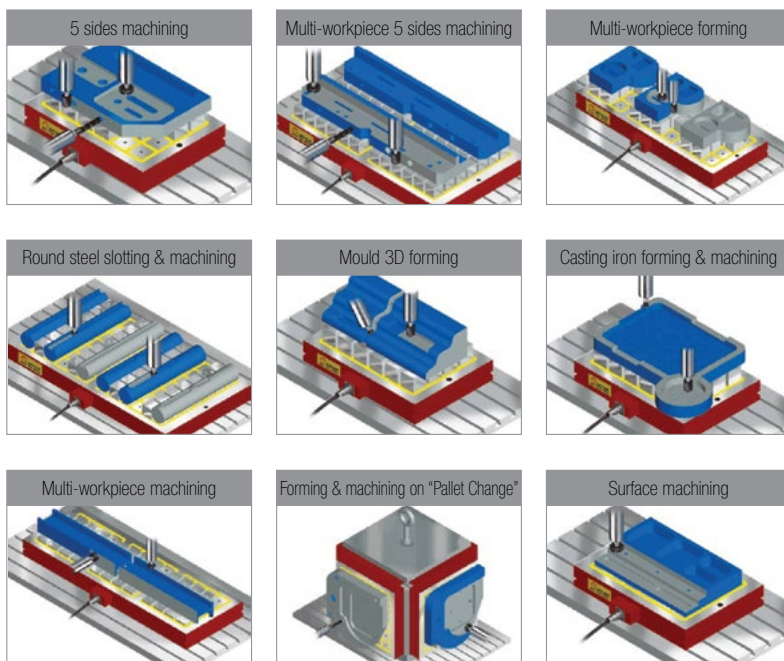

MagVISE
WORKHOLDING

Holding Power Example

EEPM 3040W chuck (left) has 20 poles, and produces 16,500 ft/lbs of holding power.

How It Works

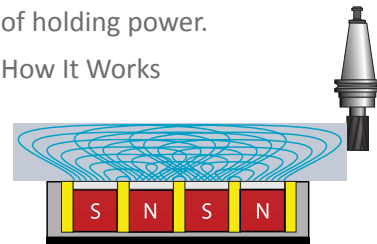

In the ON state, alnico and rare-earth magnets alternate poles, creating a powerful magnetic attraction. Holding power varies with type of material being held, surface finish, and part thickness.

Minimum recommended part size is 5" x 5" x 3/8" thick, so a minimum of 4 magnetic poles are covered by the part. Workstops, pins or part nesting techniques ensure the ability to hold small, thin parts without movement.

Induction Blocks & Subplates

We recommend using induction blocks or subplates at all times to preserve the precision ground finish and prevent damage to the face of the magnetic chuck. For more information see page 219.



Scan the QR code or enter the link below into your browser to view EEPM workholding application video.
<http://ow.ly/u1YX0>

MagVISE EEPM Application Examples



Gang part setups together and still machine



5-sides Easily hold over-size workpieces



Machining mold cavities

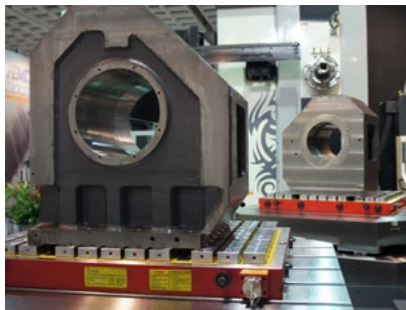

Easy integration with auto-loading systems

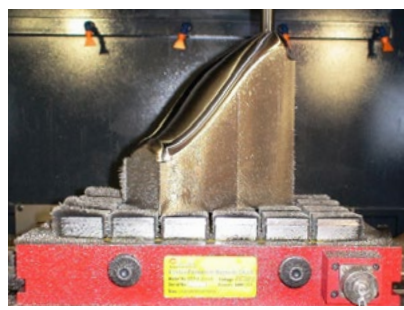

Slope milling unusual parts or 5-axis

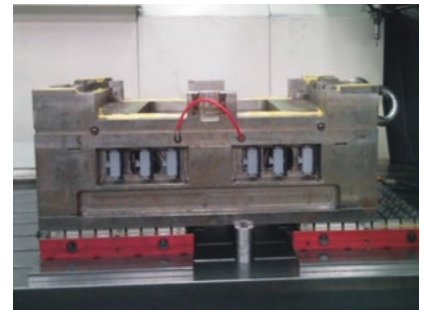

Machining injection mold application



Use spring-loaded blocks for warped stock

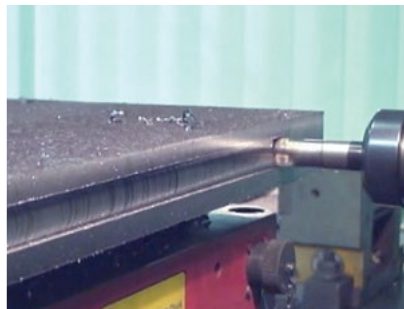

Powerful workholding for machining heavy side loads



Fast and easy to gang multiple setups together



Custom solution for holding large flat plates



High holding power for heavy cutting



Face milling on workpiece with work-stops installed

MagVISE EEPM Ordering Information

Ordering EEPM Workholding Chucks and Subplates

- Select a chuck larger than your part for maximum holding power
- Subplates are sized to match the chuck but are 1" thick – See table below
- Control is included and requires dedicated, 480v, single phase, 30A power

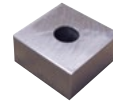

induction block

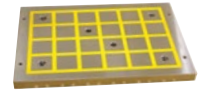

subplate

Use induction blocks or subplates at all times to preserve the precision ground finish and prevent damage to the face of the magnetic chuck.

$$S = 1.2" \quad S1 = 1" \quad G = 0.4 \quad M = 1.2"$$

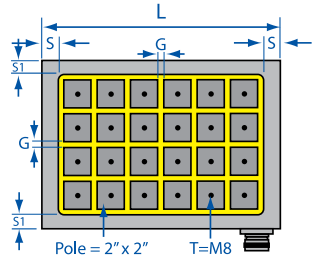

Fig. 1

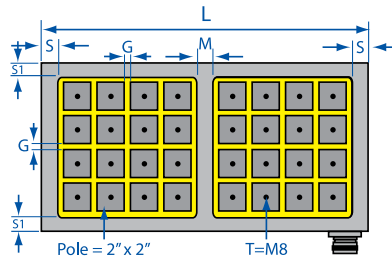

Fig. 2

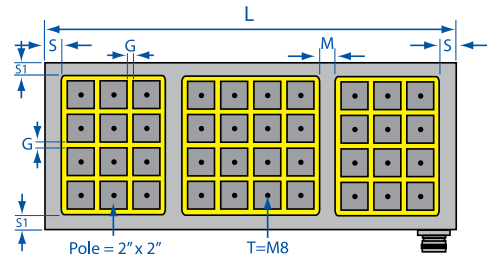

Fig. 3

MagVISE
WORKHOLDING

Model	Fig	L x W x H	Poles	Holding Power	Chuck Weight	Subplate	Controller
EEPM-2540W-480	1	16.9" x 9.4" x 2.8"	18	12,375 lbs.	110 lbs.	EEPM-2540ISP	EEPM-C1
EEPM-2560W-480	2	23.2" x 9.4" x 2.8"	24	16,500 lbs.	152 lbs.	EEPM-2560ISP	EEPM-C1
EEPM-2580W-480	3	31.9" x 9.4" x 2.8"	33	22,687 lbs.	202 lbs.	EEPM-2580ISP	EEPM-C1
EEPM-2590W-480	3	34.3" x 9.4" x 2.8"	36	24,750 lbs.	216 lbs.	EEPM-2590ISP	EEPM-C2
EEPM-25100W-480	3	39.0" x 9.4" x 2.8"	42	28,875 lbs.	244 lbs.	EEPM-25100ISP	EEPM-C2
EEPM-3030W-480	1	12.2" x 11.8" x 2.8"	16	11,000 lbs.	97 lbs.	EEPM-3030ISP	EEPM-C1
EEPM-3040W-480	1	16.9" x 11.8" x 2.8"	24	16,500 lbs.	134 lbs.	EEPM-3040ISP	EEPM-C1
EEPM-3060W-480	2	23.2" x 11.8" x 2.8"	32	22,000 lbs.	180 lbs.	EEPM-3060ISP	EEPM-C1
EEPM-3080W-480	3	31.9" x 11.8" x 2.8"	44	30,250 lbs.	255 lbs.	EEPM-3080ISP	EEPM-C2
EEPM-3090W-480	3	34.3" x 11.8" x 2.8"	48	33,000 lbs.	271 lbs.	EEPM-3090ISP	EEPM-C2
EEPM-30100W-480	3	39.0" x 11.8" x 2.8"	56	38,500 lbs.	304 lbs.	EEPM-30100ISP	EEPM-C2
EEPM-4040W-480	1	16.9" x 16.5" x 2.8"	36	24,750 lbs.	185 lbs.	EEPM-4040ISP	EEPM-C2
EEPM-4050W-480	1	18.9" x 16.9" x 2.8"	42	28,875 lbs.	209 lbs.	EEPM-4050ISP	EEPM-C2
EEPM-4060W-480	2	23.2" x 16.5" x 2.8"	48	33,000 lbs.	255 lbs.	EEPM-4060ISP	EEPM-C2
EEPM-4080W-480	3	31.9" x 16.5" x 2.8"	66	45,375 lbs.	350 lbs.	EEPM-4080ISP	EEPM-C2
EEPM-4090W-480	3	34.3" x 16.5" x 2.8"	72	49,500 lbs.	372 lbs.	EEPM-4090ISP	EEPM-C4
EEPM-40100W-480	3	39.0" x 16.5" x 2.8"	84	57,750 lbs.	425 lbs.	EEPM-40100ISP	EEPM-C4
EEPM-5060W-480	2	23.2" x 18.9" x 2.8"	56	38,500 lbs.	284 lbs.	EEPM-5060ISP	EEPM-C2
EEPM-5080W-480	3	31.9" x 18.9" x 2.8"	77	52,937 lbs.	407 lbs.	EEPM-5080ISP	EEPM-C4
EEPM-5090W-480	3	34.3" x 18.9" x 2.8"	84	57,750 lbs.	431 lbs.	EEPM-5090ISP	EEPM-C2
EEPM-50100W -480	3	39.0" x 18.9" x 2.8"	98	67,375 lbs.	482 lbs.	EEPM-50100ISP	EEPM-C4
EEPM-6060W-480	2	23.2" x 23.6" x 2.8"	72	49,500 lbs.	363 lbs.	EEPM-6060ISP	EEPM-C4
EEPM-6080W-480	3	31.9" x 23.6" x 2.8"	99	68,062 lbs.	473 lbs.	EEPM-6080ISP	EEPM-C4
EEPM-6090W-480	3	34.3" x 23.6" x 2.8"	108	74,250 lbs.	528 lbs.	EEPM-6090ISP	EEPM-C4
EEPM-60100W-480	3	39.0" x 23.6" x 2.8"	126	86,625 lbs.	603 lbs.	EEPM-60100ISP	EEPM-C4
EEPM-8080W-480	3	31.9" x 29.7" x 2.8"	121	83,187 lbs.	596 lbs.	EEPM-8080ISP	EEPM-C4

MagVISE Induction Blocks & Subplates For EEPM

Induction Blocks & Subplates

We recommend using induction blocks or subplates at all times to preserve the precision ground finish and prevent damage to the face of the magnetic chuck. Order subplates from the table on page 218.

Individual Induction Blocks

Use induction blocks to raise the workpiece above the surface of the magnet and permit machining 5 sides and thru-hole drilling. Individual induction blocks provide maximum flexibility for creating custom setups for holding difficult workpieces and warped stock.

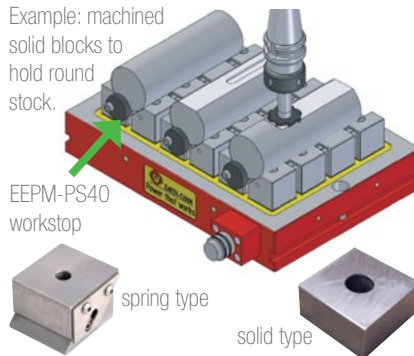
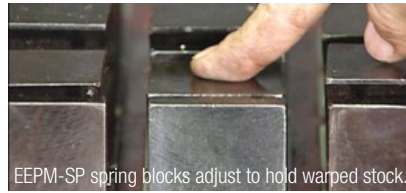

Part No.	Description	L	W	H
EEPM-SP	spring loaded (2 piece set, 8mm screw)	1.89"	1.89"	1.41"
EEPM-SPF	solid, machinable (8mm screw)	1.97"	1.97"	1.23"

Connected Induction Blocks

Makes setups faster and easier when large numbers of induction blocks are required. Choose from 2, 3, 4, or 6 pole configurations.



Part No.	Desc.	L	W	H
EEPM-IB225	2-pole block	4"	1.97"	.98"
EEPM-IB325	3-pole block	6"	1.97"	.98"
EEPM-IB425	4-pole block	8"	1.97"	.98"
EEPM-IB625	6-pole block	12"	1.97"	.98"

Angled Induction Blocks & Workstop

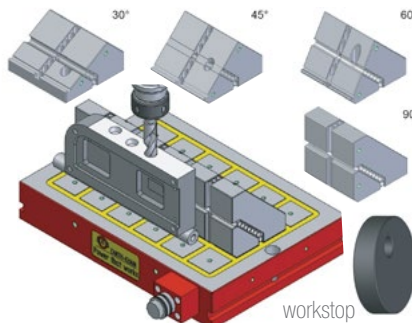

Part No.	Desc.
EEPM-IBT30	30° angle, 4-pole induction block
EEPM-IBT45	45° angle, 4-pole induction block
EEPM-IBT60	60° angle, 4-pole induction block
EEPM-IBT90	90° angle, 4-pole induction block
EEPM-PS40	round workstop (replacement)

Setup Notes

Always make sure you read, understand and follow all the Owner's Manual instructions and CAUTIONS that come with your EEPM Magnetic Chuck before setting it up and using it.

After installing your induction blocks we recommend cleanup milling the surface of your induction blocks before loading your work piece to insure that the surface height is uniform and parallel to the spindle. Subplates are precision ground and do not require cleanup milling.

Please note that the spring loaded induction blocks are NOT machineable, but the solid blocks are able to be drilled and machined as required.

Setup Examples

Machining All 5-Sides Freely



For full machining on all 5-sides (including thru-hole drilling or boring) induction blocks or subplates are required or damage to the magnetic chuck may occur.

Holding Warped Material

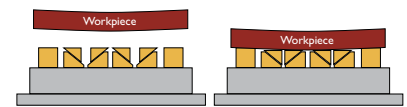

Use EEPM-SPF induction blocks on the corners and EEPM-SP spring loaded blocks everywhere else so the induction blocks adjust to match the warped stock.

Part Nesting Techniques



For machining small, thin, or irregular parts that do not have much metal to attract the magnet, you can create a shallow nest, or pocket in a subplate or induction blocks to secure the part and prevent lateral movement. For part nests that you will use over-and-over again on repeat jobs use subplates to save setup time.

MagVISE EEPM-C Modular Workholding Chucks

Features:

- Modular connection from 2, to 16 chucks as needed
- Operate as many as 16 chucks with 1 control
- 8,250 lbs. holding power (each chuck)*

Advantages:

- Easy to setup and adjust for large or irregular parts
- Reduced investment compared to larger EEPM chucks
- Easy to move and setup from machine to machine



For workholding of ferrous materials only.

EEPm-C chucks provide almost unlimited flexibility to hold workpieces of varying sizes. Use toe-clamps or bolts to position EEPm-C magnets anywhere on your machine bed or pallet to fit your workpiece.

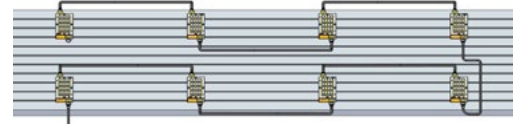

*Holding power varies with type of material being held, surface finish, and part thickness.

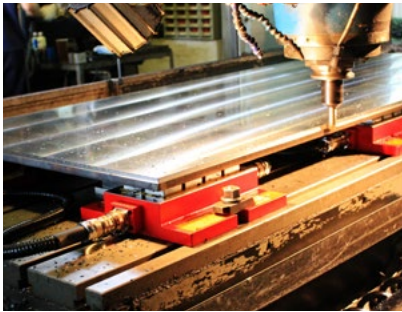

Use for fast setups on plate stock

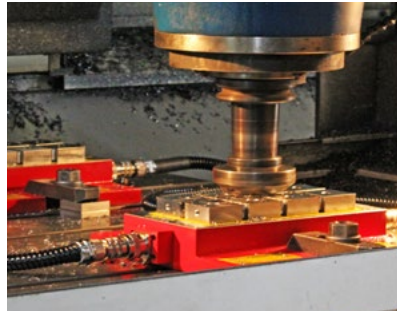

Clean up induction blocks prior to loading part

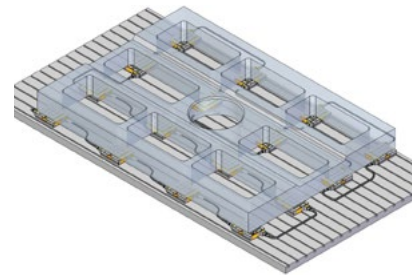

the possibilities are endless...

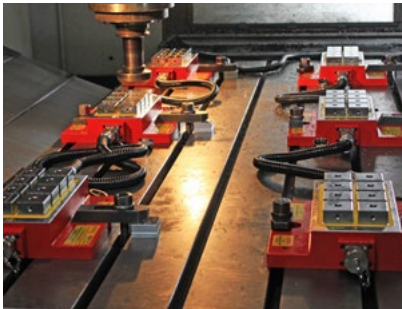

Modular setups adjust easily to part



Provides uniform workholding - no part distortion

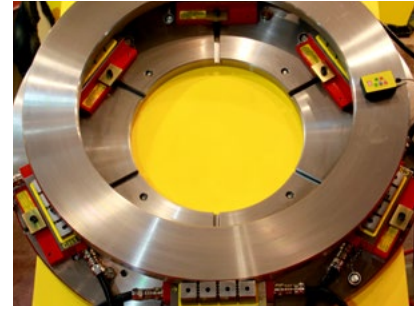

Circular applications are no problem



Large tooth sprocket being machined

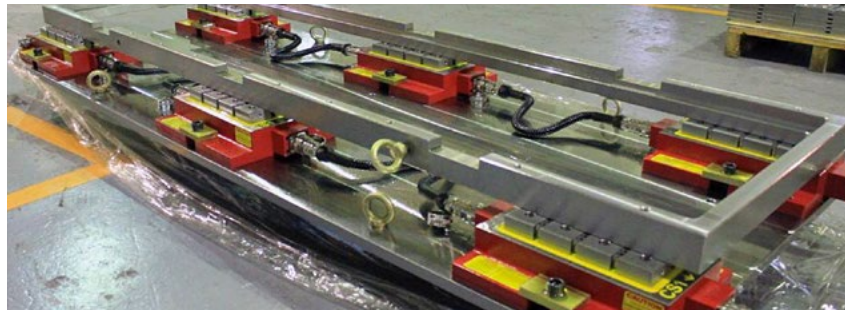

Palletized setup staged for loading

Operate up to 16 chucks using 1 control

MagVISE
WORKHOLDING

232 Call (800) 597-3921 or (317) 803-8000 for a fast friendly quote. • Fax: (317) 803-8001



MagVISE EEPM-C Ordering Information

Ordering EEPM-C Modular Chucks

- *Select the number of chucks required*
- *Select the control required to operate the number of chucks needed*
- *Select the number and length of connection cables required*

We recommend using induction blocks at all times to preserve the surface finish of your magnetic chuck, and prevent damage to the face of the magnetic chuck.

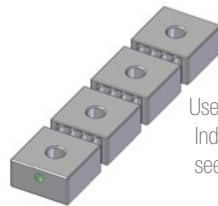

Use with EEPM-IB425 Induction Blocks see page 219

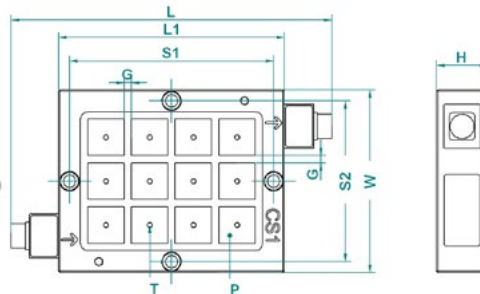
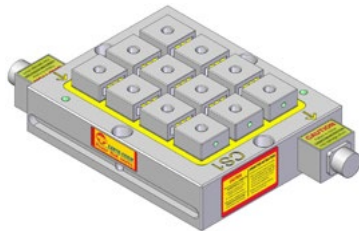

Chuck	L	W	L1	S1	S2	Poles	Holding Power*
EEPM-2530C	16.75"	9.84"	12.25"	11.0"	8.66"	12	8,250 lbs.

*Holding power varies with type of material being held, surface finish, and part thickness.

Control requires a dedicated 480V single phase, 30A power supply



C4 control features 4 channels to control up to 16 chucks. Control each channel independently.

Control	Description	L x W x H	Channels	Qty. Chucks
EEPM-C1C	Control for 1-4 EEPM-C magnetic chucks	10.6" x 7" x 5"	1	1-4
EEPM-C2C	Control for 1-8 EEPM-C magnetic chucks	10.6" x 7" x 5"	2	1-8
EEPM-C4C	Control for 1-16 EEPM-C magnetic chucks	10.6" x 7" x 5"	4	1-16



Connection Cables	Length
EEPM-CC03	11.8"
EEPM-CC05	19.6"
EEPM-CC10	39.37"
EEPM-CC15	59"



Installation Example

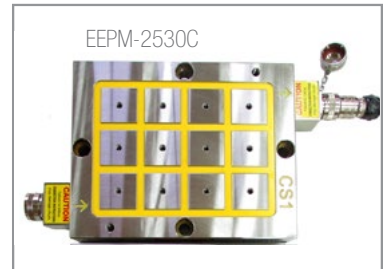

Up to 16 chucks can be operated from 1 control.



Position the chucks on the machine bed.



Lock them in position using bolts provided.



Connect the control cables to chucks and control

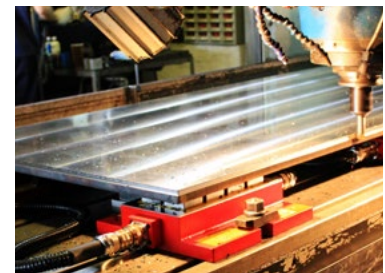

Position workpiece and start machining.

MagVISE EEPM-V For Horizontal Machining

Features:

- Up to 68,640 lbs. holding power*
- Choose from 2 or 4 sided chucks
- 36, 42, or 100 pole chucks, 16.9" to 29.9"

Advantages:

- Reduce setup & part change-over time by 50% or more!
- Machine freely on all 5-sides to reduce operations
- Very uniform holding = No workpiece deformation

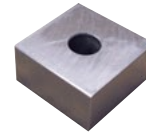

Induction Blocks
see page 219

Induction Blocks & Subplates

We recommend using induction blocks or subplates at all times to preserve the precision ground finish and prevent damage to the face of the magnetic chuck. For more information see page 219.

*4 sizes available

For workholding of ferrous materials only.
See page 223 for holding power ratings.

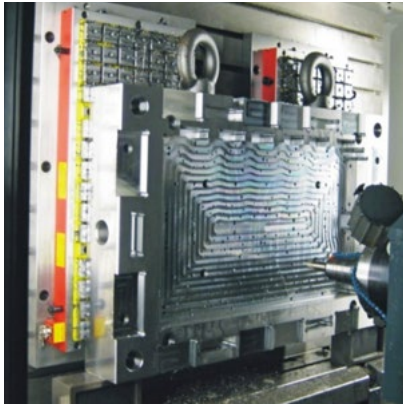

Mold making application



2-sided EEPM on palletized system

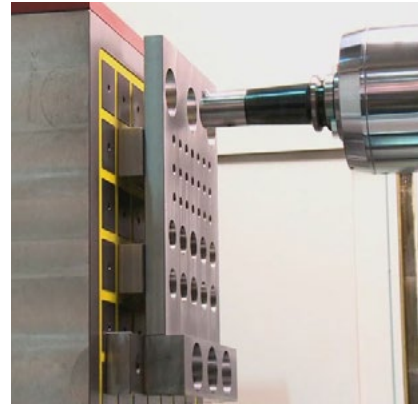

Hole-making applications are no problem



Complex part shapes - 5 sides machining

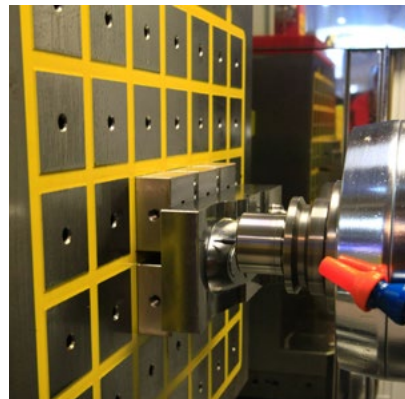

Finish pass using small tools

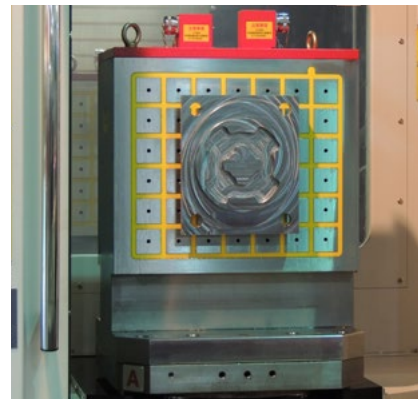

Palletized horizontal workholding chuck

MagVISE
WORKHOLDING

234 Call (800) 597-3921 or (317) 803-8000 for a fast friendly quote. • Fax: (317) 803-8001



MagVISE EEPM-V Ordering Information

Ordering EEPM-V Chucks

- Select the number of faces and chucks required
- Control is included with chuck
- Order induction blocks from page 219

We Manufacture Custom Tombstones

- Built to your specifications.
Call us to discuss your needs.
- (800) 597-3921 or local (317) 803-8000

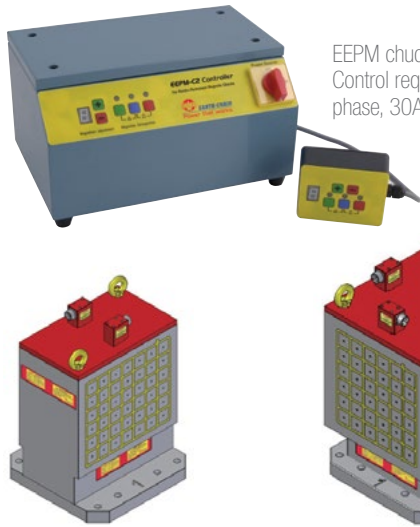

EEPM chucks includes controller and remote.
Control requires a dedicated 480V single phase, 30A power supply

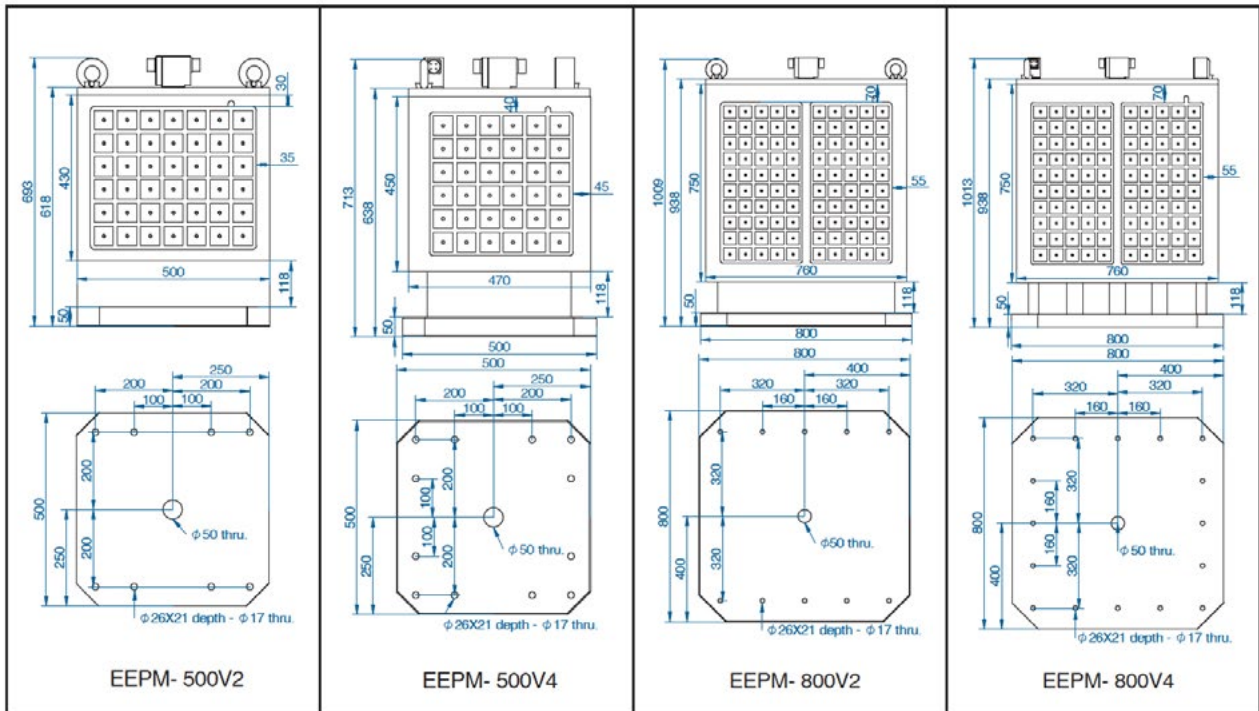
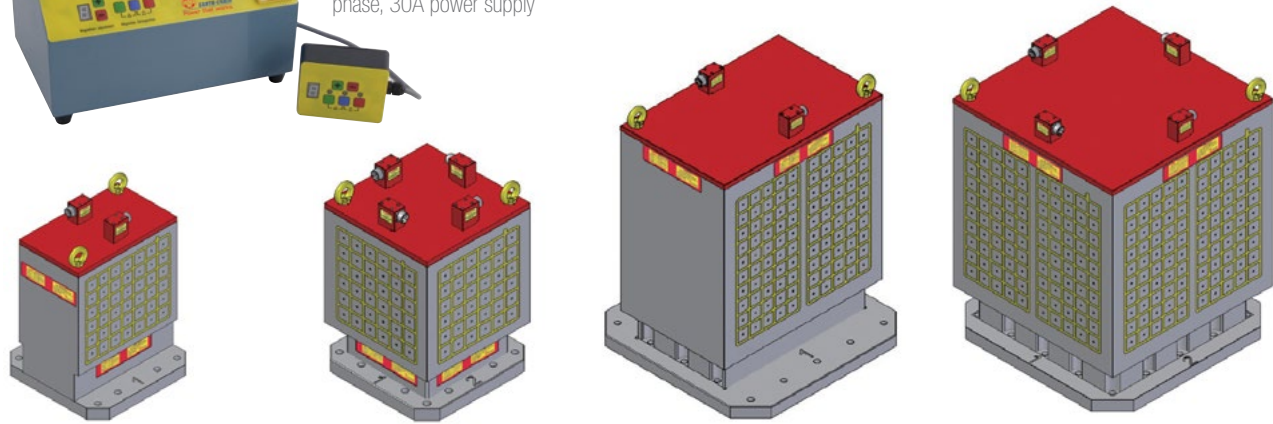

Model	Face (L x W)	No. Faces	No. Poles	Holding Power / Face	Chuck Wt.	Controller
EEPM-500V2	16.9" x 19.68"	2	42	28,820 lbs.	1,058 lbs.	EEPM-C2
EEPM-500V4	17.7" x 18.5"	4	36	24,640 lbs.	1,124 lbs.	EEPM-C2
EEPM-800V2	29.5" x 29.9"	2	100	68,640 lbs.	1,675 lbs.	EEPM-C2
EEPM-800V4	29.5" x 29.9"	4	100	68,640 lbs.	1,786 lbs.	EEPM-C2

MagVISE EEPM-CIR for Vertical Turning & 5-Axis



For workholding of ferrous materials only.
9 sizes to choose from. Custom sizes available. includes controller and remote

Advantages:

- Reduce setup & part change-over time by 50% or more!
- Machine freely on all 4-sides & top so you can cut the full part profile in only 1 operation
- Very uniform holding = No workpiece deformation

EEPМ-CIR chucks are a powerful and fast workholding solution optimized for horizontal or vertical turning centers and 5-axis machining. Using magnetic workholding you can clamp/unclamp the part in only seconds. Reduce setup down-time to increase machine up-time. Control is included with chuck.

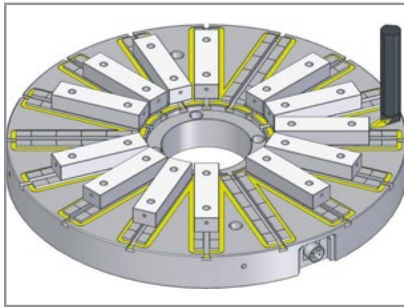

Machine induction blocks for easy part positioning

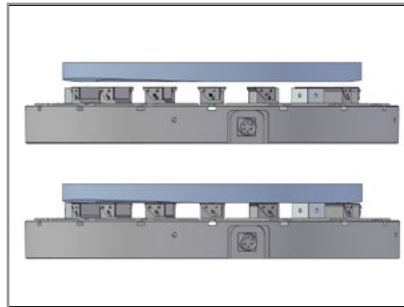

Use with EEPM-SP blocks to hold warped stock

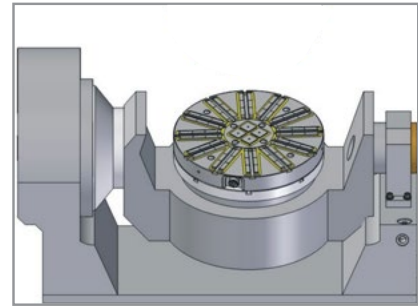

Speed up setups for 5-axis tables

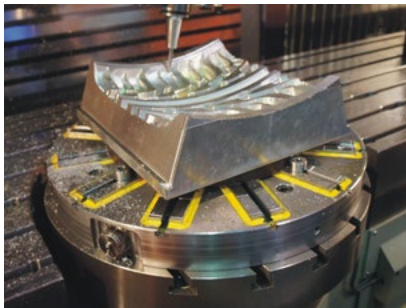

3, 4, and 5-axis applications



Even workholding - no part distortion

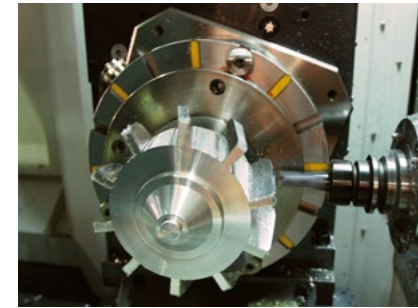

Off-axis rotation on horizontal mill

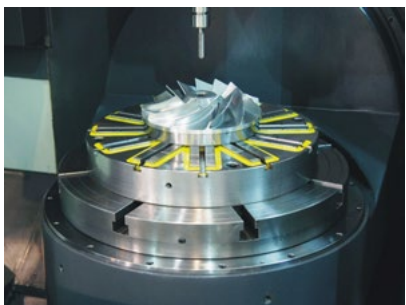

Holds very small or very large parts

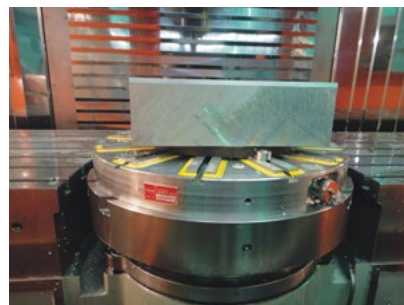

Custom chucks available to suit your machine

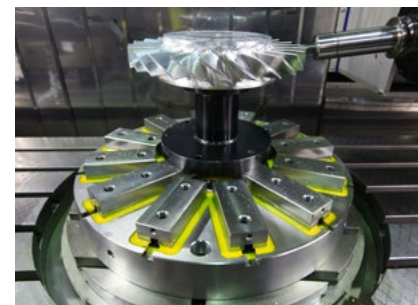

Hold complex parts without complicated setups!

MagVISE
WORKHOLDING

236 Call (800) 597-3921 or (317) 803-8000 for a fast friendly quote. • Fax: (317) 803-8001



MagVISE EEPM-CIR Ordering Information

Select the Chucks From Tables Below

- We build custom chucks for your specific needs. Call us to discuss.
- (800) 597-3921 or local (317) 803-8000

EEPM chucks includes controller and remote
Control requires a dedicated 480V single phase,
30A power supply

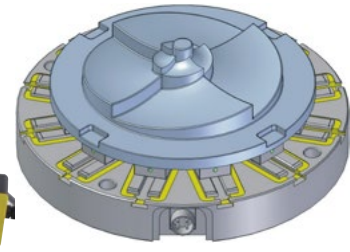

step and slope milling for an impeller

Induction Blocks & T-Slot Sliding Blocks for EEPM CIR Chucks



EEPM-SP



EEPM-SPF

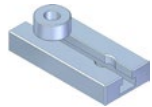

Sliding T-Slot

EEPM-CIRB120



EEPM-CIRB170

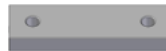

EEPM-CIRB245



EEPM-CIRB335



EEPM-CIRB220



EEPM-CIRB270



Use induction blocks to preserve the precision ground finish and prevent damage to the face of the chuck. Induction blocks to raise the workpiece above the surface of the magnet and permit machining 5 sides and thru-hole drilling.

Use T-Slot Sliding Blocks as adjustable workstops for part alignment. See pg. 219 for more induction block options and ideas.

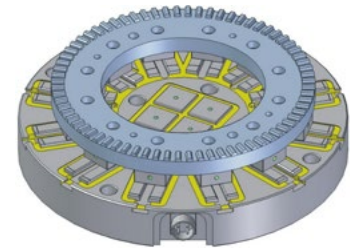

circular chuck setup for gear cutting

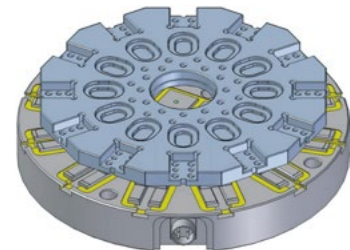

pocket milling and face milling

Part No.	Description	L	W	H
EEPM-SP	spring loaded (2 piece set, 8mm screw)	1.89"	1.89"	1.41"
EEPM-SPF	solid, machinable (8mm screw)	1.97"	1.97"	1.23"
EEPM-20T	sliding T-slot for use with EEPM-SPF	4.72"	1.97"	.78"
EEPM-30T	sliding T-slot for use with EEPM-SP blocks	4.72"	1.97"	1.18"
EEPM-CIRB120	induction block for CIR500 chuck	4.72"	1.97"	.78"
EEPM-CIRB170	induction block for CIR600 chuck	6.69"	1.97"	.78"
EEPM-CIRB245	induction block for CIR800 chuck	9.64"	1.97"	.78"
EEPM-CIRB335	induction block for CIR1000 chuck	13.18"	1.97"	.78"
EEPM-CIRB220	induction block for CIR500 chuck	8.66"	1.97"	.78"
EEPM-CIRB270	induction block for CIR600 chuck	10.62"	1.97"	.78"

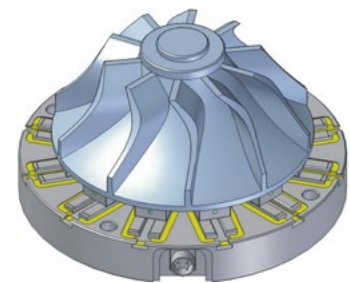

5-axis turbine blade machining

Model	Dim. (O.D. x I.D. x H)	No. Poles	Holding Power	Weight	Control
EEPM-CIR500	19.7" x 0" x 2.75"	12 + 4	12,345 lbs.	229 lbs.	C1
EEPM-CIR600	23.6" x 0" x 2.75"	12 + 4	17,636 lbs.	326 lbs.	C2
EEPM-CIR800	31.5" x 9.84" x 3.34"	16	28,219 lbs.	665 lbs.	C2
EEPM-CIR1000	39.4" x 9.84" x 3.34"	16	42,328 lbs.	1,038 lbs.	C4
EEPM-CIR1250	49.6" x 19.68" x 4.33"	24	52,910 lbs.	1,825 lbs.	C4
EEPM-CIR1500	59.0" x 19.68" x 4.72"	24	74,075 lbs.	2,921 lbs.	C8
EEPM-CIR1600	64.2" x 19.68" x 4.72"	24	84,657 lbs.	3,322 lbs.	C8
EEPM-CIR1800	71.6" x 31.49" x 4.72"	36	111,112 lbs.	5,048 lbs.	C8
EEPM-CIR2000	80.7" x 39.37" x 5.11"	36	111,112 lbs.	5,489 lbs.	C8

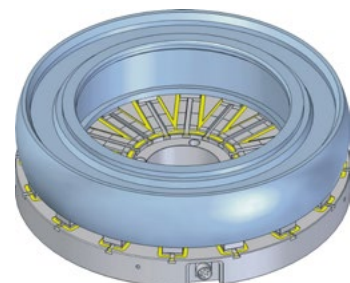

round part turning O.D. and I.D.

We stand behind all our CNC tooling solutions from spindle to workpiece.

www.techniksusa.com

MagVISE EEPM-CIRS for Machining & Grinding



For workholding of ferrous materials only.

EEPM chucks includes controller and remote. Control requires a dedicated 480V single phase, 30A power supply

Advantages:

- Versatile round chucks for many different applications
- Reduce setup & part change-over time by 50% or more!
- Machine freely on 5-sides so you can cut the full part profile in only 1 operation

There are 9 stock sizes of EEPM-CIRS chucks to choose from (see table below). We also can build custom chucks for your machine.

We recommend using induction blocks at all times to preserve the precision ground finish and prevent damage to the face of the chuck. You can easily modify induction blocks to your part requirements. Use EEPM-SP induction blocks for holding warped stock.

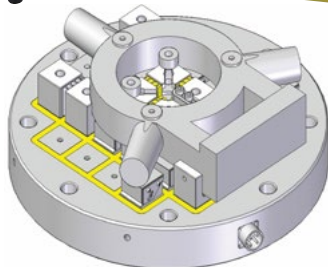

Use induction blocks as workstops to hold hard parts

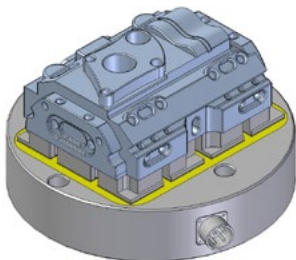

Machine full 5 sides using induction blocks

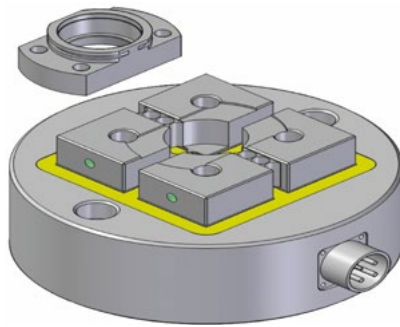

Machine nests to hold smaller parts

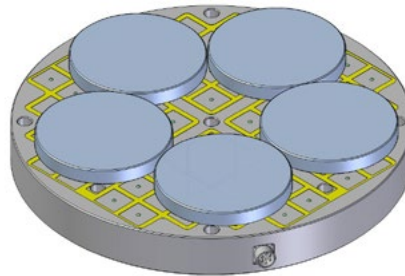

Gang parts together on larger chucks for efficiency

MagVISE
WORKHOLDING

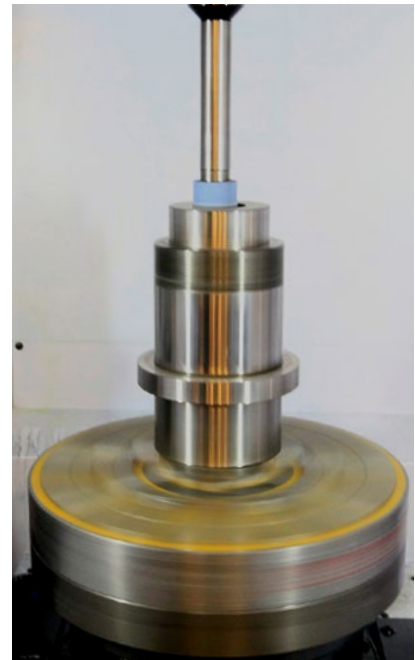

Honing application

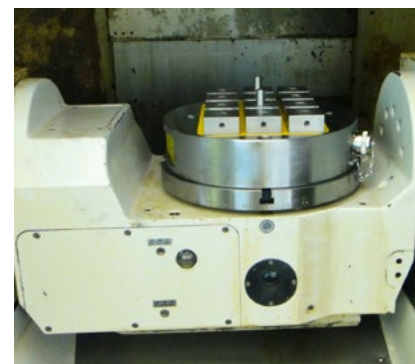

Easy integration with 5-axis tables

Model	Dim. (O.D. x H)	No. Poles	Holding Power	Weight	Control
EEPM-CIRS200	7.99" x 2.75"	4	2,204 lbs.	35 lbs.	C1
EEPM-CIRS300	12.0" x 2.75"	12	6,612 lbs.	77 lbs.	C1
EEPM-CIRS500	19.68" x 2.75"	32	17,632 lbs.	214 lbs.	C1
EEPM-CIRS600	24.4" x 2.75"	52	28,652 lbs.	330 lbs.	C2
EEPM-CIRS700	27.55" x 2.75"	76	41,876 lbs.	421 lbs.	C4
EEPM-CIRS800	32.28" x 2.75"	96	52,896 lbs.	578 lbs.	C4
EEPM-CIRS900	35.82" x 3.14"	120	66,120 lbs.	798 lbs.	C4
EEPM-CIRS1000	40.15" x 3.14"	164	90,364 lbs.	1,022 lbs.	C8
EEPM-CIRS1100	45.54" x 3.14"	204	112,404 lbs.	1,203 lbs.	C8

MagVISE EEPM-IT Index Table

Features:

- Pneumatic table makes rotation easy
- Indexed in 5 degree increments
- Full 360° rotation either left or right

Advantages:

- Add indexing capability to your horizontal mill
- Machine 5-sides freely and reduce setup time 50%
- Very uniform holding = No workpiece deformation



Pull the black knob out to unclamp table and rotate part. Push knob in to clamp. Index table requires 90 psi shop air for rotation.

We recommend using induction blocks or subplates at all times to preserve the precision ground finish and prevent damage to the face of the magnetic chuck.

For more information see page 219.



Scan QR code above or visit: <http://goo.gl/fb4nkk>



Use EZ-Lift lifting magnet to quickly load your workpiece

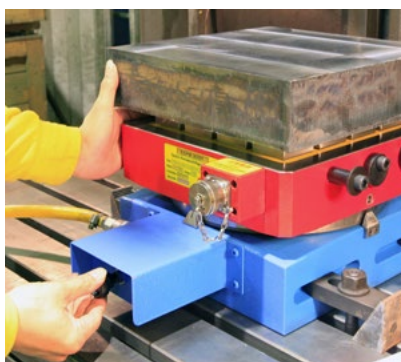

Pull knob to rotate part up to 360 degrees

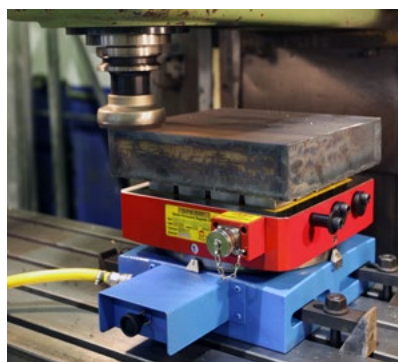

Use induction blocks to machine full 5 sides freely



Add indexing capability to your mill

Model	Face (L x W x H)	Max. Load	No. Poles	Holding Power	Squareness	Repeatability	Weight
EEPM-300IT	11.81" x 11.81" x 7.59"	1,100 lbs.	16	11,023 lbs.	.0004"	.0004"	229 lbs.
EEPM-470IT	18.5" x 18.5" x 7.36"	2,200 lbs.	49	33,730 lbs.	.0005"	.0004"	490 lbs.
EEPM-600IT	23.6" x 23.6" x 8.89"	4,400 lbs.	72	49,604 lbs.	.0007"	.0005"	996.5 lbs.
EEPM-800IT	31.5" x 31.5" x 11.88"	6,600 lbs.	144	99,208 lbs.	.0007"	.0005"	2,162.5 lbs.

All orders ship same day! Ground orders in by 2:00 and expedited orders in by 5:00 EST.

www.techniksusa.com

MagVISE EEPM-PIM Injection Mold Magnets

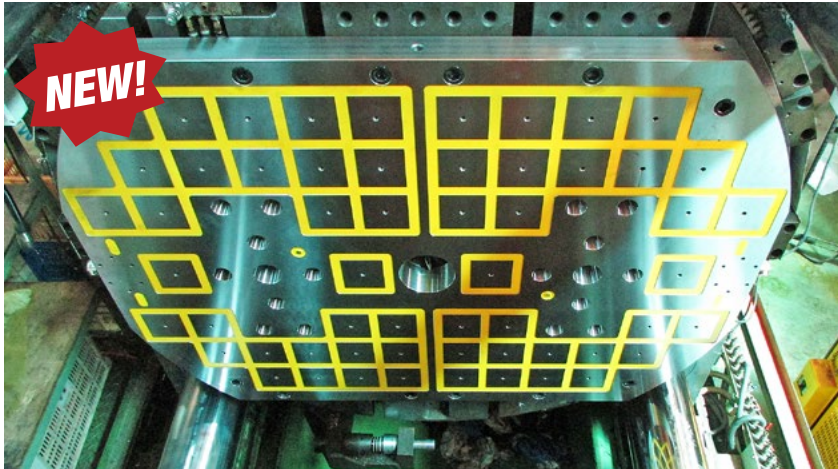

Magnetic mold clamping is much faster than other methods to save machine time.

Injection-mold magnets are quickly replacing traditional mold clamping methods world-wide. The investment in PIM magnets is quickly repaid by faster mold setup and change-over times.

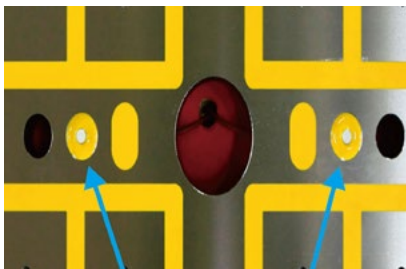

Proximity sensors ensure correct positioning.

Also, machine capacity increases by an average of 20% because PIM magnets require less room in the machine cube. Call us for custom size magnets.



Controls require operator to use both hands.

Features

- Position and clamp in just minutes!
- Proximity sensors ensure position
- Dual controls lock-out machine during operation for safety

Benefits

- Save 60% setup & change-over time
- Increase machine capacity 20%
- Greatly increase your productivity just by changing clamping method

MagVISE
WORKHOLDING



Watch the video demo at this url:
<http://ow.ly/tajls>



Load and install PIM magnet with bolts

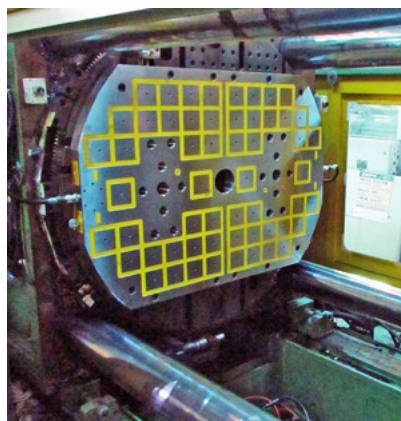

PIM & controls integrate with your machine.

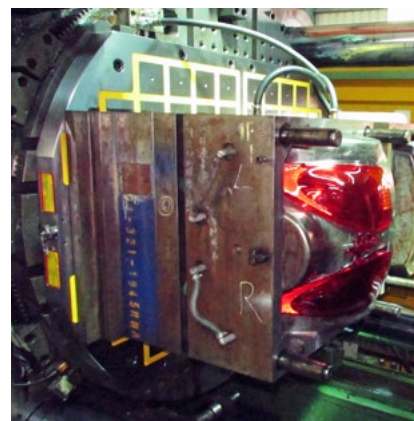

Mold is held perfectly, & change-over is fast.

Model	Face (L x W x H)	Max Temp (F)	Holding Power	Pole Size (mm)	Power Supply
EEPm-1200PIM	59" x 59" x 2.75"	248°	185,188 lbs.	92 x 92	35A, 480V single phase
EEPm-950PIM	57" x 41.3" x 2.75"	248°	148,150 lbs.	92 x 92	30A, 480V single phase
EEPm-400PIM	41.3" x 25.6" x 2.75"	248°	52,910 lbs.	92 x 92	40A, 480V single phase

MagVISE ECB Magnetic Workholding Vises



Features

- Powerful rare-earth magnets for up to 4,620 lbs. holding power (per vise)
- Gang multiple vises together and increase holding power as needed
- Quickly and easily adjust size of setup and number of chucks as needed

Benefits

- Reduce setup and change-over down time by 50%
- Freely machine on all 5-sides to reduce number of operations
- No workpiece deformation

4 sizes available

For workholding of ferrous materials only. Each ECB vise includes everything required to setup and begin workholding.

Scan the QR code or enter this link: <http://ow.ly/u21Nm> to view a video demo.

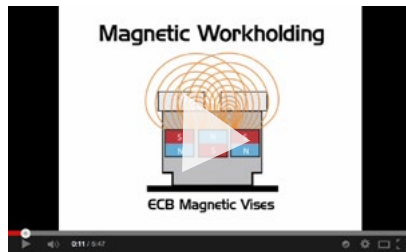

ECB Magnetic Vises provide fast, efficient workholding for all types of CNC machining applications. They are easy to install or move from machine to machine, and making changes to existing setups is fast.



ECB magnetic vises hold irregular stock sizes, warped stock, and large workpieces, without special fixturing.

Setup Examples

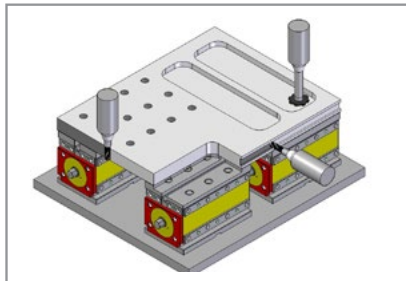

Machine freely on 5-sides using induction blocks

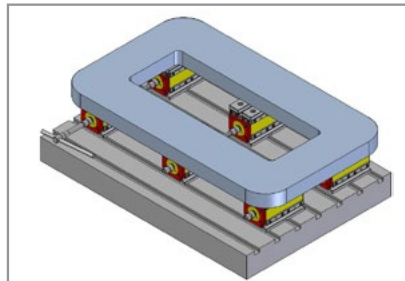

Switch-connect to turn ON/OFF multiple vises

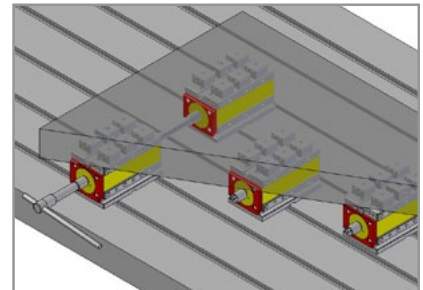

Position ECB vises just where you need them

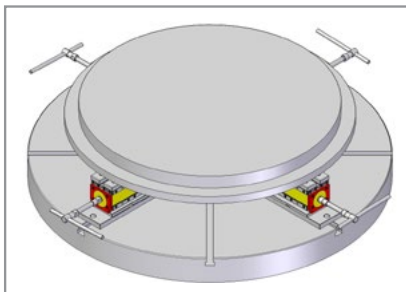

Vertical turning setups are faster with ECB vises

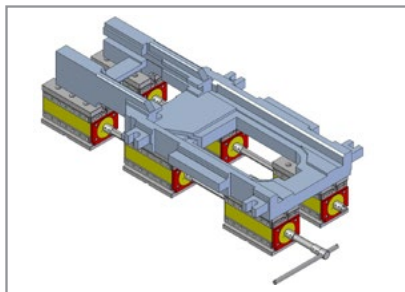

Cut complex part shapes O.D. and I.D.

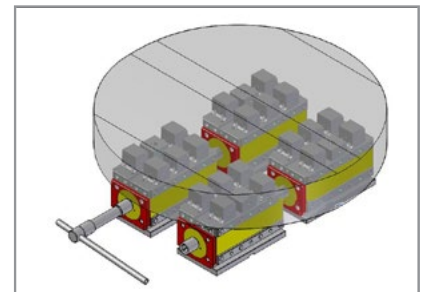

Hold large and small parts of all shapes

MagVISE ECB Applications



You can use 1 ECB vise for each part...



...or use multiple ECB vises positioned as needed to hold large parts.



Machine freely on 5-sides



Switch-connect ECB vises to turn ON/OFF simultaneously



Tombstones for horizontal milling

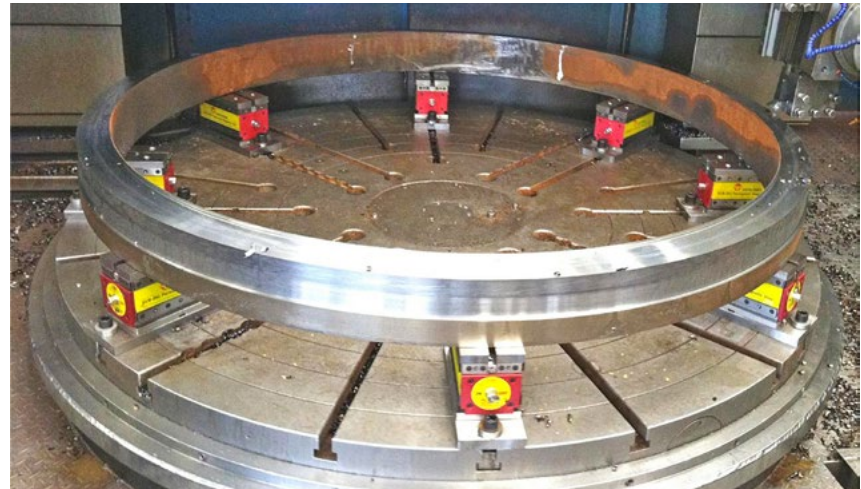

ECB magnetic vises are easy to setup for vertical turning. Machine both O.D. and I.D.

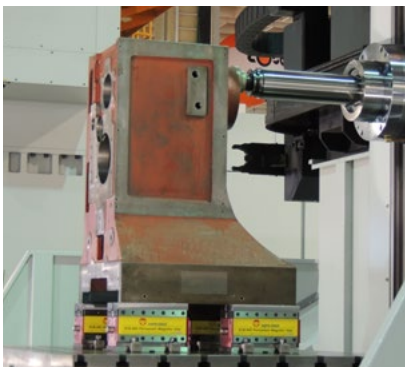

ECB vises are used for large or small parts



Even huge workpieces like this one are easily held and can be machined on 5-sides.

MagVISE
WORKHOLDING

242 Call (800) 597-3921 or (317) 803-8000 for a fast friendly quote. • Fax: (317) 803-8001



MagVISE ECB Ordering Information



4 sizes available

to fit your application needs. Each ECB vise includes 2 machinable induction blocks, wrench, extension and socket, switch-connect socket assembly, 2 stop plates, 4 toe clamps.



EEPM-SP spring type

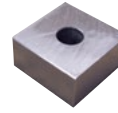

EEPM-SPF solid type



Use EEPM-SP spring-loaded induction blocks and EEPM-SPF blocks together to hold warped stock. See page 219.

Use induction blocks at all times to prevent damage to the face of the magnetic vise. You can easily modify induction blocks to adapt your setup to part requirements. Please note that the spring loaded induction blocks are NOT machineable, but the solid blocks are able to be drilled and machined as required. After installing your ECB vise we recommend cleanup milling the surface of your induction blocks before loading your work piece to insure that the surface height is uniform and parallel to the spindle.

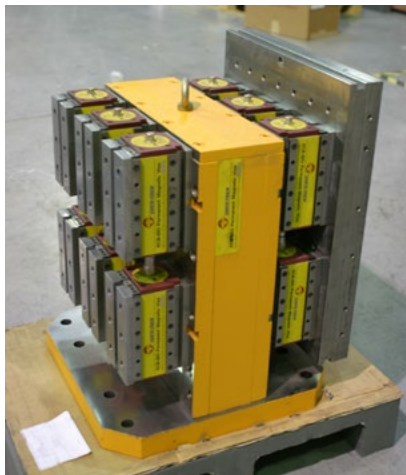

ECB magnetic vises easily integrate with pallet changing and tombstone systems used in production cells. Call us at (800) 597-3921 or (317) 803-8000 for a fast quote.

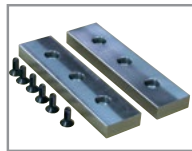

Induction blocks and work stops are included.

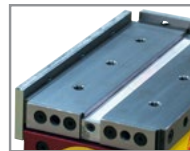

Switch-connect vises to turn them ON/OFF in unison.

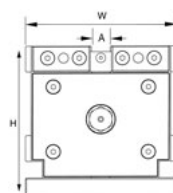

end view

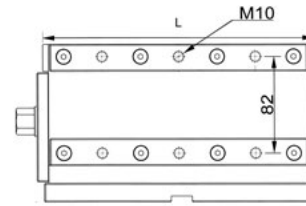

side view

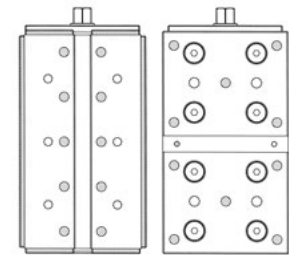

top and bottom view



Ordering Information

Part No.	L x W x H	A	B	Min. Stock Thickness	Holding Power	Weight
ECB-050	5" x 3" x 3"	.47"	.47"	0.4"	1,100 lbs.	15 lbs.
ECB-075	6.8" x 3" x 3"	.47"	.47"	0.4"	1,650 lbs.	19 lbs.
ECB-120	7.3" x 4.2" x 4.2"	.62"	.59"	0.6"	2,640 lbs.	40 lbs.
ECB-210	9.2" x 5.2" x 5.3"	.65"	.84"	0.8"	4,620 lbs.	80 lbs.

Part No.	Description	L x W x H
EEPM-SPF	1, soft fixed induction block, 8mm screw - use with ECB-SP50 spring blocks.	1.97" x 1.97" x 1.23"
EEPM-SP	2, spring loaded induction block, 8mm screw - use with ECB-SPF50 on corners.	1.89" x 1.89" x 1.41"

Note: Holding power depends on workpiece size, material, surface finish, contact area with magnet, and workpiece thickness. Always make sure your read, understand and follow the instructions that come with your ECB vise.

MagVISE EDMT Surface Grinding Chucks



For induction blocks see page 236.

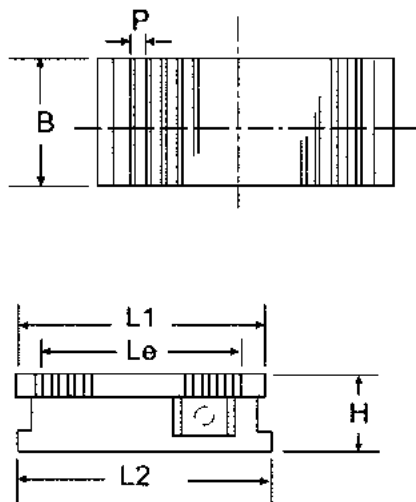

EDMT (All-Purpose Variable Pole Design)

Alternating thick/thin magnetic poles provides best holding power for both thick and thin workpieces.

- *EDM-READY: fully submersible, brass welded faceplate which can be machined if needed, and protects the magnetic system from penetration of coolant.*
- *Needs no electricity. Provides a constant source of workholding power.*
- *Low-profile design increases Z-axis stroke*
- *Housing and bottom plate are free of magnetism —will not magnetize machine bed or bearings.*

Variable Pole

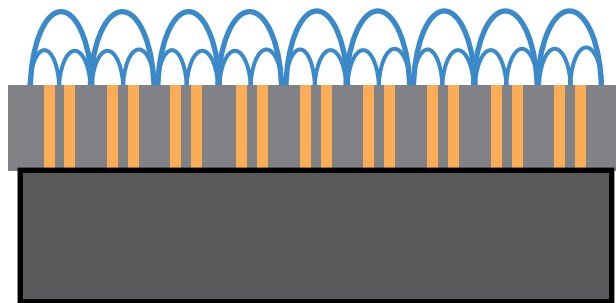

*New variable pole design creates magnetic fields that hold both thin and thick workpieces equally well.

Model	Pole Pitch (P)	L x W x H	Weight
EDMT-1018	11.2 (1.6+2+1.6+6)	7" x 4" x 2.5"	16 lbs.
EDMT-1325	11.2 (1.6+2+1.6+6)	10" x 5" x 2.5"	23 lbs.
EDMT-1530	11.2 (1.6+2+1.6+6)	12" x 6" x 2.5"	33 lbs.
EDMT-1535	11.2 (1.6+2+1.6+6)	14" x 6" x 2.5"	38 lbs.
EDMT-1545	11.2 (1.6+2+1.6+6)	18" x 6" x 2.5"	44 lbs.
EDMT-2040	11.2 (1.6+2+1.6+6)	16" x 8" x 2.5"	57 lbs.
EDMT-2045	11.2 (1.6+2+1.6+6)	18" x 8" x 2.5"	66 lbs.
EDMT-2050	11.2 (1.6+2+1.6+6)	20" x 8" x 2.5"	79 lbs.
EDMT-2550	4 + 12	20" x 10" x 2.5"	130 lbs.
EDMT-3060	3 + 15	24" x 12" x 2.5"	198 lbs.

MagVISE EDTW Fine Pole Surface Grinding Chucks



For induction blocks see page 236.

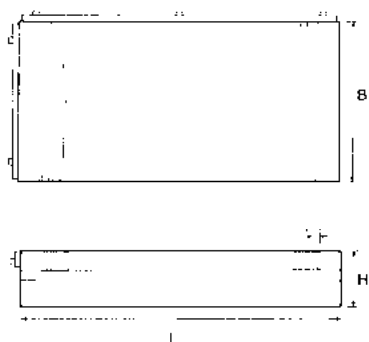

EDTW chucks have up to 15 tons of holding force. (150 lbs./inch²)

EDTW (MicroPITCH Fine Pole Design)

Fine pole design provides best holding power for surface grinding of small or thin workpieces.

- Brass welded faceplate can be machined if needed, and protects the magnetic system from penetration of coolant.
- Needs no electricity. Provides a constant source of workholding power.
- Low-profile design increases Z-axis stroke
- Housing and bottom plate are free of magnetism —will not magnetize machine bed or bearings.

Fine Pole

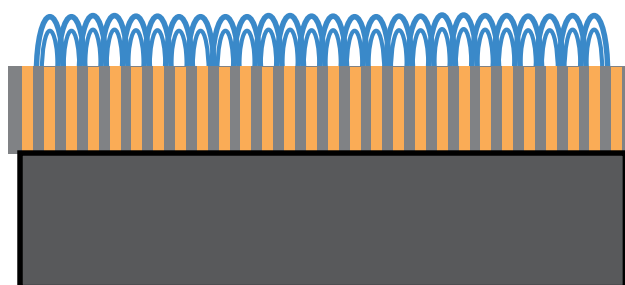

Fine pole magnets creates strongest magnetic field close to surface for holding thin workpieces.

Model	Pole Pitch (P)	L x W x H	Weight
EDTW-1018	2 (1+1)	7" x 4" x 2"	15 lbs.
EDTW-1325	2 (1+1)	10" x 5" x 2.25"	29 lbs.
EDTW-1515	2 (1+1)	6" x 6" x 2.25"	20 lbs.
EDTW-1530	2 (1+1)	12" x 6" x 2.5"	49 lbs.
EDTW-1535	2 (1+1)	14" x 6" x 2.5"	53 lbs.
EDTW-1545	2 (1+1)	18" x 6" x 2.5"	68 lbs.
EDTW-2040	2 (1+1)	16" x 8" x 2.5"	82 lbs.
EDTW-2045	2 (1+1)	18" x 8" x 2.5"	90 lbs.
EDTW-2050	2 (1+1)	20" x 8" x 2.5"	99 lbs.
EDTW-2550	2 (1+1)	20" x 10" x 2.5"	132 lbs.

MagVISE EET Surface Grinding Chucks



For induction blocks see page 236.

EET (Wide Spaced Pole Design)

Wider spacing magnetic poles for general surface grinding of both thick and thin workpieces.

- Brass welded faceplate which can be machined if needed, and protects the magnetic system from penetration of coolant.
- More than 1,000 OHMs resistance
- Low-profile design increases Z-axis stroke
- Housing and bottom plate are free of magnetism —will not magnetize machine bed or bearings.

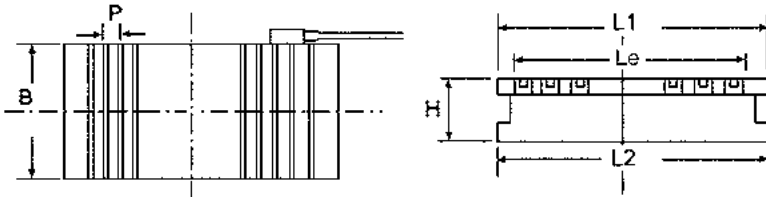

Model	Pole Pitch (P)	L x W x H	Volts	Amps	Weight
EET-1530	15 (3+12)	12" x 6" x 3"	DC90V	0.18	44 lbs.
EET-1535	15 (3+12)	14" x 6" x 3"	DC90V	0.19	53 lbs.
EET-1545	15 (3+12)	18" x 6" x 3"	DC90V	0.19	66 lbs.
EET-2040	15 (3+12)	16" x 8" x 3"	DC90V	0.28	84 lbs.
EET-2045	15 (3+12)	18" x 8" x 3"	DC90V	0.28	90 lbs.
EET-2050	15 (3+12)	20" x 8" x 3"	DC90V	0.36	99 lbs.
EET-2550	15 (3+12)	20" x 10" x 3"	DC90V	0.46	143 lbs.
EET-3060	15 (3+12)	24" x 12" x 3"	DC90V	0.86	179 lbs.
EET-3070	15 (3+12)	28" x 12" x 3"	DC90V	0.81	205 lbs.
EET-3090	15 (3+12)	35" x 12" x 3"	DC90V	1.05	276 lbs.
EET-4060	19 (3+16)	24" x 16" x 3.5"	DC90V	0.95	287 lbs.
EET-4070	19 (3+16)	28" x 16" x 3.5"	DC90V	1.21	333 lbs.
EET-4080	19 (3+16)	32" x 16" x 3.5"	DC90V	1.31	384 lbs.
EET-40100	19 (3+16)	40" x 16" x 3.5"	DC90V	1.33	487 lbs.
EET-50100	19 (3+16)	40" x 20" x 3.5"	DC90V	1.46	595 lbs.
EET-50150	19 (3+16)	60" x 20" x 3.5"	DC90V	3.37	893 lbs.
EET-60100	19 (3+16)	40" x 24" x 3.5"	DC90V	2.80	728 lbs.
EET-60150	19 (3+16)	60" x 24" x 3.5"	DC90V	2.85	1091 lbs.
EET-80100	19 (3+16)	40" x 32" x 3.5"	DC90V	3.80	970 lbs.

MagVISE EET-W Fine Pole Surface Grinding Chucks



For induction blocks see page 236.

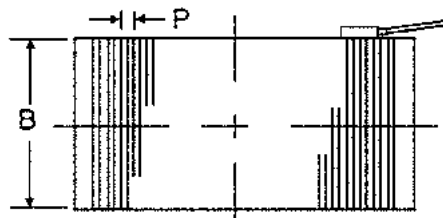
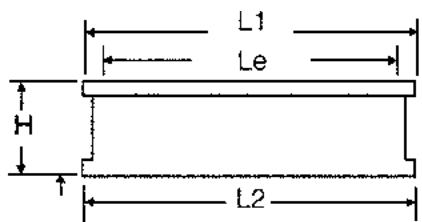

EET-W (Fine Pole Design)

Fine pole design optimized for maximum holding power
for surface grinding of thin workpieces

- Brass welded faceplate which can be machined if needed, protects the magnetic system from penetration of coolant
- More than 1,000 OHMs resistance
- Low-profile design increases Z-axis stroke
- Housing and bottom plate are free of magnetism —will not magnetize machine bed or bearings.

Fine Pole

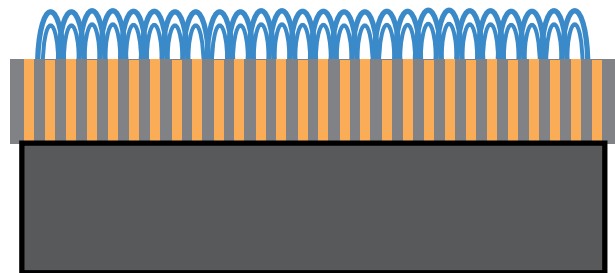

Fine pole magnets creates strongest magnetic field close to surface for holding thin workpieces.

Model	Pole Pitch (P)	L x W x H	Volts	Amps	Weight
EET-1530W	4(1+3)	12" x 6" x 4.5"	DC90V	0.73	73 lbs.
EET-1535W	4(1+3)	14" x 6" x 4.5"	DC90V	0.61	88 lbs.
EET-1545W	4(1+3)	18" x 6" x 4.5"	DC90V	0.98	110 lbs.
EET-2040W	4(1+3)	16" x 8" x 4.5"	DC90V	1.10	139 lbs.
EET-2045W	4(1+3)	18" x 8" x 4.5"	DC90V	1.20	157 lbs.
EET-2050W	4(1+3)	20" x 8" x 4.5"	DC90V	1.40	176 lbs.
EET-2550W	4(1+3)	20" x 10" x 4.5"	DC90V	1.00	247 lbs.
EET-3060W	4(1+3)	24" x 12" x 4.5"	DC90V	1.50	331 lbs.

MagVISE Induction Blocks for Surface Grinding

EHT Induction Blocks:

- Extends magnetic force to hold bar, round, or irregular shapes
- EDM-READY: fully submersible, brass sealed
- For fine-pole and standard pole applications

Choose from lengthwise (L) or width-wise (W) pole direction

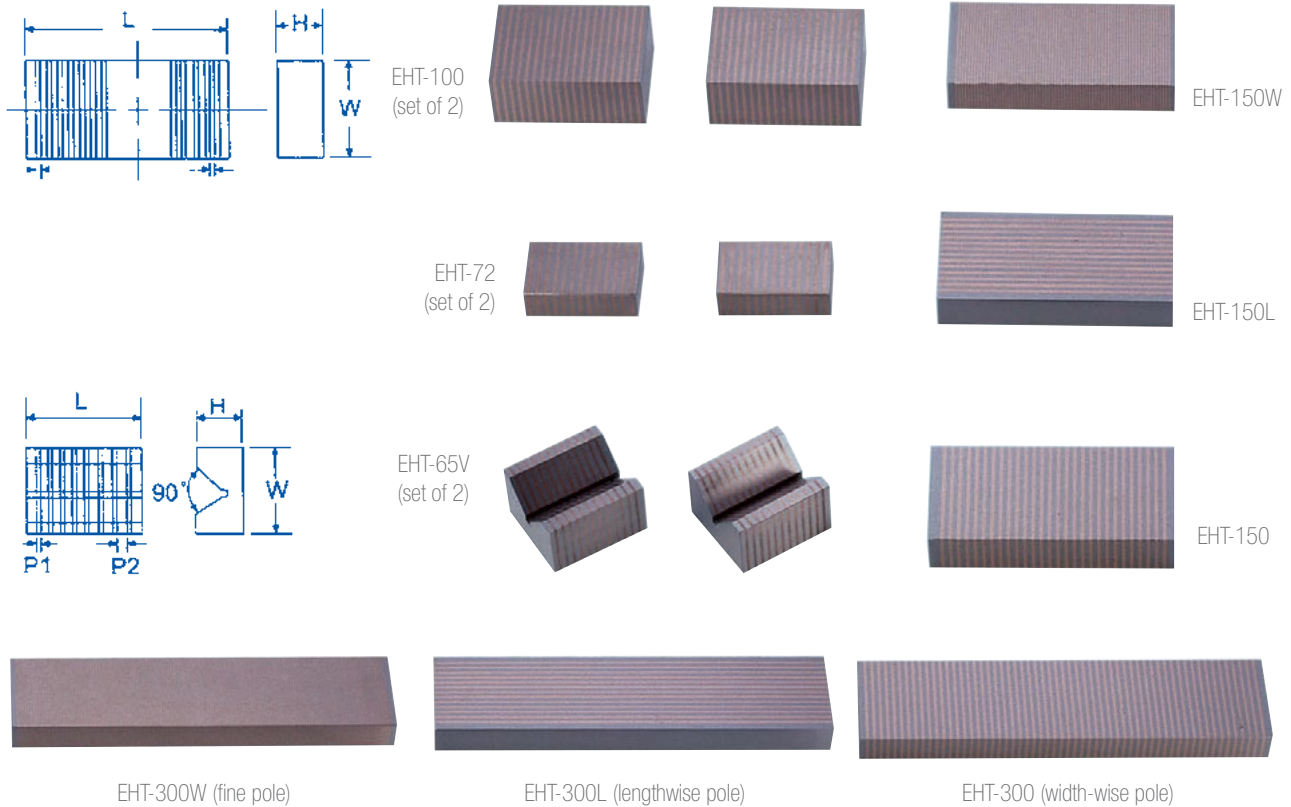

Model	Qty.	L x W x H	Pole Pitch P1	Pole Pitch P2	Weight
EHT-65V	2	2.5" x 2.5" x 1.5"	2	3	4 lbs. (x2)
EHT-72	2	3" x 2" x 1"	2	3	7 lbs. (x2)
EHT-100	2	4" x 3" x 1.5"	2	3	10 lbs. (x2)
EHT-150	1	6" x 3" x 1"	2	3	5 lbs.
EHT-300	1	12" x 3" x 1"	2	3	10 lbs.
EHT-150L	1	6" x 3" x 1"	2	3	5 lbs.
EHT-300L	1	12" x 3" x 1"	2	3	10 lbs.
EHT-150W	1	6" x 3" x 1"	1+1	1+1	5 lbs.
EHT-300W	1	12" x 3" x 1"	1+1	1+1	10 lbs.

MagVISE Magnetic V-Blocks

ECE Magnetic Blocks

- Dozens of uses around the shop
- Fast setups of bar stock or round steel
- Powerful magnetic base, ON-OFF switch



ECE-100 / ECE-150

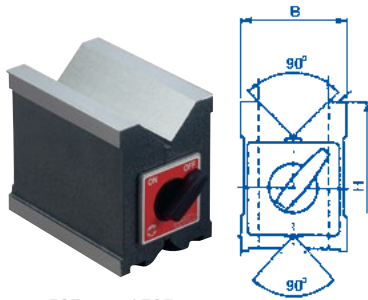
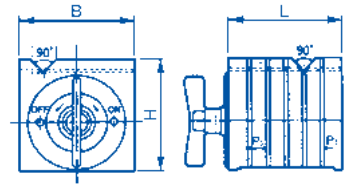

ECE-208 / ECE-212

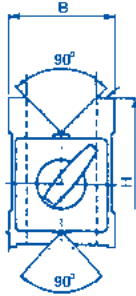

ECE-612

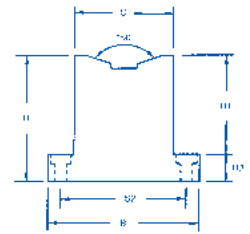
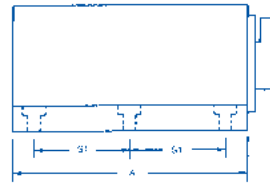

Model	Holding Power		Dimensions mm								
	V-Face	Surface	B	L	H	C	H1	H2	S1	S2	Weight
ECE-100	61 lbs.	88 lbs.	100	100	100	-	-	-	-	-	14.5 lbs.
ECE-150	110 lbs.	308 lbs.	150	150	150	-	-	-	-	-	53 lbs.
ECE-208	121 lbs.	154 lbs.	56	80	72	-	-	-	-	-	6.5 lbs.
ECE-212	198 lbs.	242 lbs.	75	115	100	-	-	-	-	-	11 lbs.
ECE-612	242 lbs.	350 lbs.	76	118	62	50	50	12	48	62	5.5 lbs.

ECE Magnetic V-Block Sets

- For grinding, marking, measuring and other light machining operations
- Each pair made to identical dimensions
- Sold in pairs only

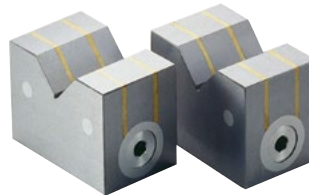

ECE-507

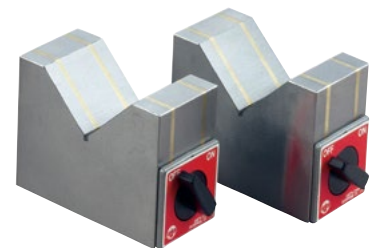

ECE-510

Model	Holding Power	Applicable Diameter mm	Dimension mm				Weight
			B	L	H		
ECE-507	33 lbs.	50	40	72	50	2.2 lbs. x 2	
ECE-510	44 lbs.	80	50	100	80	6.6 lbs. x 2	

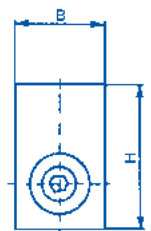
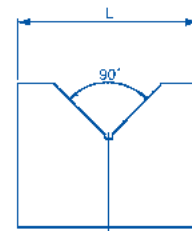

Chuck Controls and Demagnetizers

ERD-505, 510, 515 Features:

- Work with any electromagnetic chucks
- Demagnetizing time is 6-15 seconds
- Precisely regulates the magnetic force

ERD-520 Features:

- For larger, more powerful electromagnetic chucks
- Can operate two chucks at the same time
- Demagnetizing time is 8-15 seconds



ERD-505



ERD-510, ERD-515



ERD-520

Model	Input Voltage/Single Phase	Output Volts	Output Amps	Dim. L x W x H	Wt.
ERD-505-110	AC 110/220V	DC 0-100V	5A	8" x 5.5" x 5"	8 lbs.
ERD-510-220	AC110/220/440V	DC 0-120V	10A	6" x 13" x 10"	33 lbs.
ERD-515-220	AC 220/440V	DC 0-120V	15A	6" x 13" x 10"	44 lbs.
ERD-520-220	AC 220/440V	DC 0-120V	20A	7" x 15" x 12"	71 lbs.

Please specify voltage when ordering.

EDH Demagnetizers



EDH-123



EDH-180

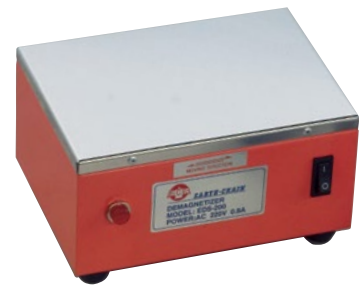

EDH-200

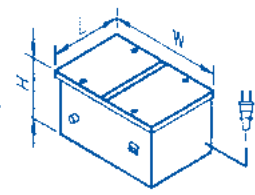
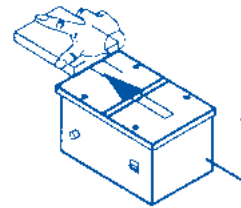
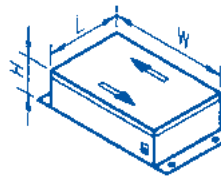
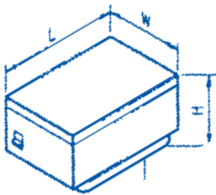

Model	Description	Power	Capacity	Duty Cycle	Dim. L x W x H	Wt.
EDH-123-110	Portable, light weight, for big machines	AC 110V	110VA	90%	123 x 83 x 83mm	4 lbs.
EDB-180-110	Up to 20 minutes continuous operation	AC 110/220V	220VA	50%	127 x 180 x 90mm	9 lbs.
EDS-200-110	Continuous operation, double-coil design	AC 110V	330VA	100%	150 x 200 x 100mm	19 lbs.

MagVISE
WORKHOLDING

250 Call (800) 597-3921 or (317) 803-8000 for a fast friendly quote. • Fax: (317) 803-8001

